

W. TARBUCK.

CLAMP.

APPLICATION FILED NOV. 2, 1911.

1,026,475.

Patented May 14, 1912.

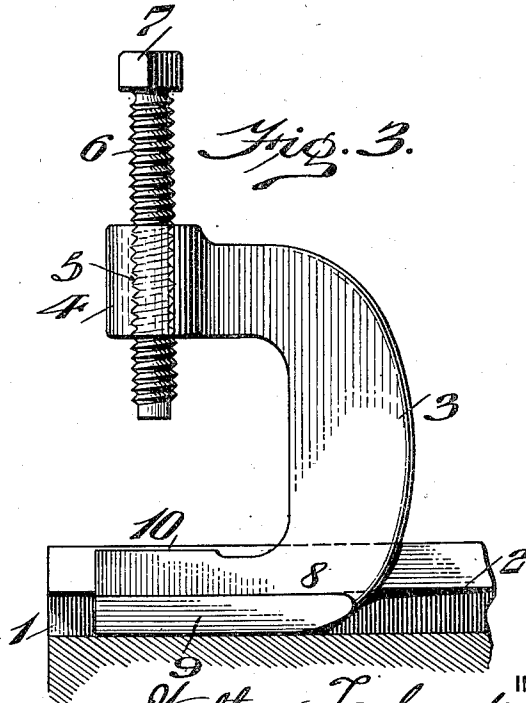
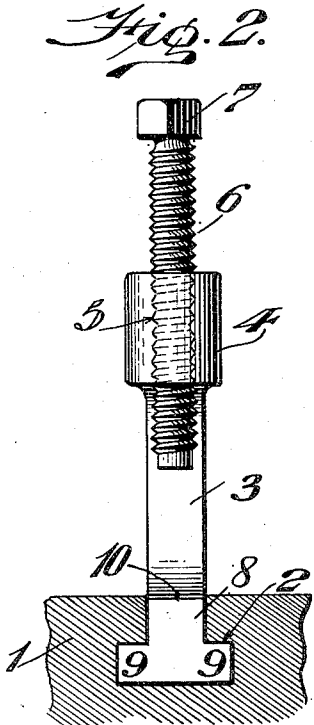
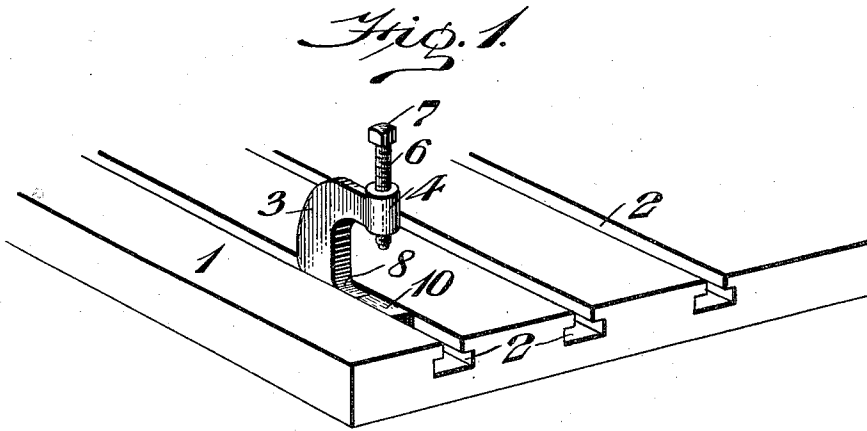

WITNESSES

*H. Dieterich*  
*L. Dowville.*

INVENTOR

*Walter Tarbuck.*  
BY *Wiedersheim Paubert & Co.*  
ATTORNEYS

# UNITED STATES PATENT OFFICE.

WALTER TARBUCK, OF PHILADELPHIA, PENNSYLVANIA.

## CLAMP.

1,026,475.

Specification of Letters Patent.

Patented May 14, 1912.

Application filed November 2, 1911. Serial No. 658,096.

*To all whom it may concern:*

Be it known that I, WALTER TARBUCK, a subject of the King of Great Britain, residing in the city and county of Philadelphia, State of Pennsylvania, have invented a new and useful Clamp, of which the following is a specification.

My invention relates to clamps for securing the work upon the tables or beds of planing machines or similar machines, and it consists of an improved clamp which may be adjusted in the T-grooves of such tables or beds to clamp the work upon the same.

It further consists of other novel features of construction all as will be hereinafter fully set forth.

The annexed drawings and following description set forth in detail, one mechanical form in which the principle of the invention may be embodied.

In said annexed drawings:—Figure 1 represents a perspective view of a portion of a table of a planing machine or similar metal-working machine, illustrating one of my improved clamps in position upon the same. Fig. 2 represents a front view of the clamp. Fig. 3 represents a side view of the clamp.

Similar numerals of reference indicate corresponding parts in the figures.

Referring to the drawings, the numeral 1 indicates the table or bed of a metal-working machine, having undercut grooves or T-grooves or slots, 2, to receive the clamping means for securing the work upon the face of the table.

The clamp consists of a yoke or frame, 3, substantially U-shaped one limb of which has a vertical head, 4, formed with a threaded bore, 5, in which a clamping screw, 6, having a head, 7, for turning it, is fitted. The head may be of any suitable shape or size, according to preference and use. The opposite limb or foot, 8, of the yoke has lateral flanges, 9, at its lower edge, thus forming a T-shaped tongue or foot to fit in the T-groove of the table, and said flanged limb is straight for the greater part of its length and for the full length of the flanges, so that the clamp may slide with its T-shaped tongue in the T-groove of the table. The upper edge of the lower limb of the clamp has a raised outer portion, 10, against

which the work bears when acted upon by the clamp-screw.

In practice, one or more clamps, according to the character of the work, is slid with its T-tongue into the T-groove of the table until in proper position on the same, whereupon the clamp-screw is screwed down upon the work, clamping the same against the face of the table. The clamp will thus be secured in the groove of the table and will secure the work upon the table. By having the lower limb or foot of the clamp and its lateral flanges opposed to the clamping-screw, the latter, when screwed down upon the work, will draw the flanges upward in the T-groove and tighten the clamp in the groove while clamping the work against the table. The strain upon the clamp will be borne by the entire flanged foot. In clamps of this character where the clamp-frame is secured at one end in the table or bed and the clamping-screw forces the work solely against the surface of such table, the entire strain will fall upon the frame at the point where the latter is secured in the table, making such frame liable to breakage at such point.

The clamp may be used as an ordinary clamp to hold several pieces of work together in the ordinary manner.

Having thus described my invention, what I claim as new and desire to secure by Letters Patent, is:—

1. A clamp of the character stated, comprising a U-shaped integral yoke having one work-supporting limb forming a foot having lateral flanges adapted to engage a T-groove in a machine table, and a clamping screw threaded into the opposite limb of the yoke and directly opposed to said work-supporting limb.

2. A clamp of the character stated, comprising a U-shaped integral yoke formed with an upper limb having a vertical screwthreaded bearing and a lower limb provided with laterally projecting flanges at its lower edge forming a straight T-shaped tongue adapted to engage a T-groove in a machine table and with a raised portion, and a clamping-screw in the threaded bearing in the upper limb and directly opposed to the raised portion of the lower limb.

3. A machine table formed with a T-

55

60

65

70

75

80

85

90

95

100

105

groove, a clamp comprising a U-shaped in-  
tegral yoke formed with an upper limb hav-  
ing a vertical screwthreaded bearing and a  
lower limb provided with laterally project-  
5 ing flanges at its lower edge forming a  
straight T-shaped tongue slidable in the  
T-groove and with a raised portion, and a

clamping-screw in the threaded bearing in  
the upper limb and directly opposed to the  
raised portion of the lower limb.

WALTER TARBUCK.

Witnesses:

WM. FECHER,  
C. D. McVAY.