

F. ZWIGARD & R. SCHWÖRER.
WINE PRESS.

No. 522,334.

Patented July 3, 1894.

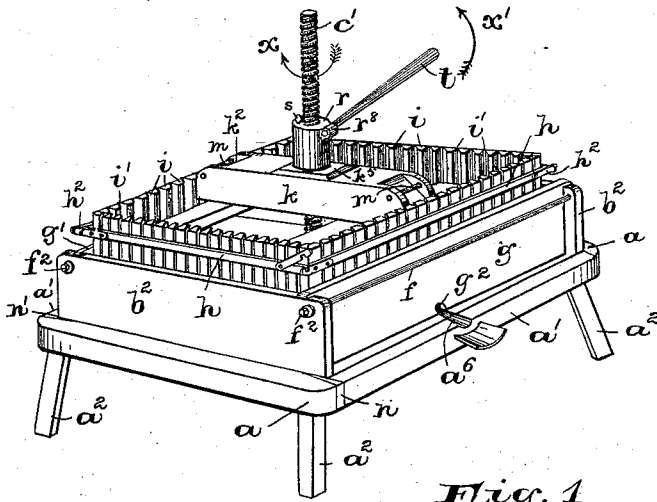

Fig. 1

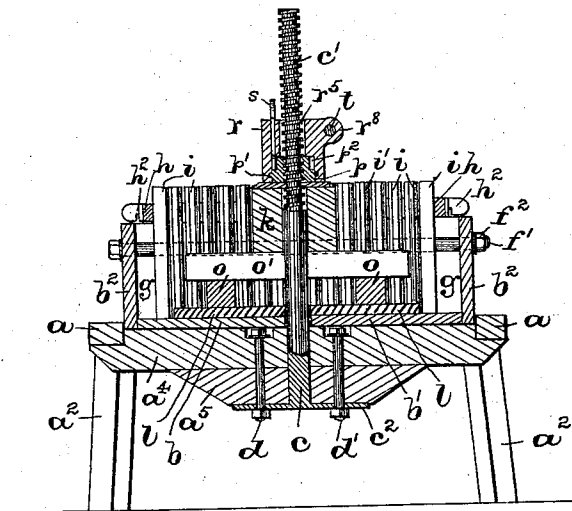

Fig. 2

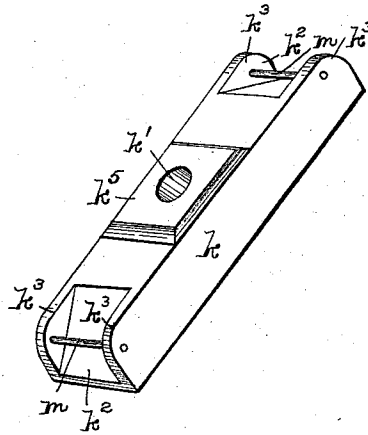

Fig. 3

WITNESSES:

Wm. H. Canfield, Jr.
H. W. Marsh.

INVENTORS:

Frank Zwigard
and
Rudolf Schwörer.
BY Fred C. Fraentzel, ATTY.

F. ZWIGARD & R. SCHWÖRER.
WINE PRESS.

No. 522,334.

Patented July 3, 1894.

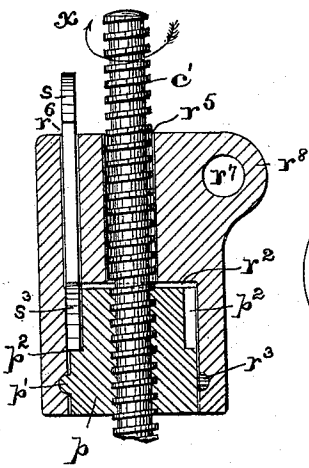

Fig. 4

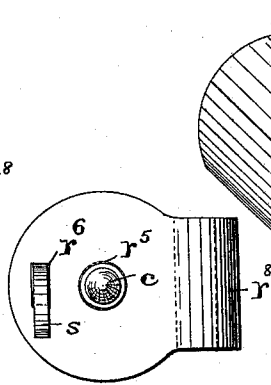

Fig. 5

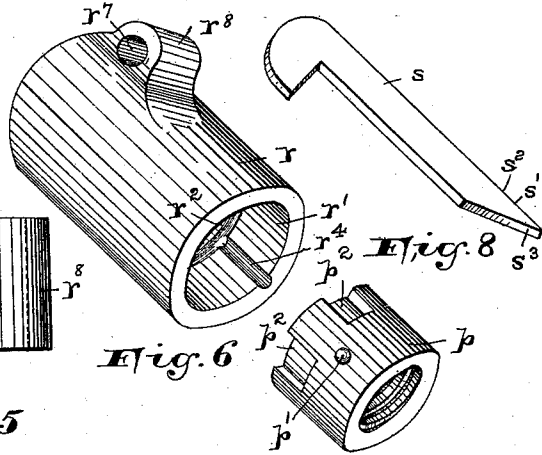

Fig. 6

Fig. 7

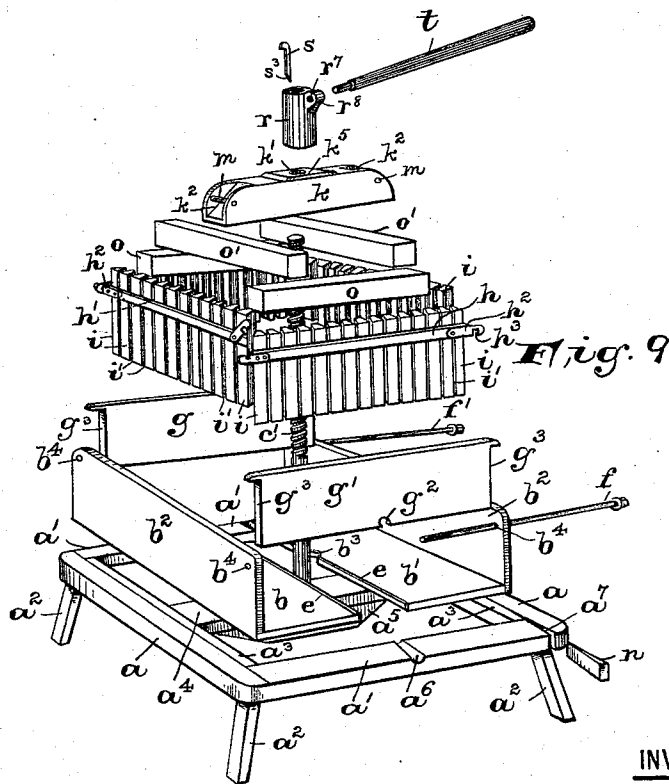

Fig. 9

WITNESSES:

Wm. H. Canfield, Jr.
H. W. Marsh.

INVENTORS:

Frank Zwigard
and
Rudolf Schwörer.
BY Fred C. Fraentzel, ATTY.

UNITED STATES PATENT OFFICE.

FRANK ZWIGARD AND RUDOLF SCHWÖRER, OF NEWARK, NEW JERSEY.

WINE-PRESS.

SPECIFICATION forming part of Letters Patent No. 522,334, dated July 3, 1894.

Application filed January 15, 1894. Serial No. 496,865. (No model.)

To all whom it may concern:

Be it known that we, FRANK ZWIGARD and RUDOLF SCHWÖRER, both subjects of the Emperor of Germany, residing at Newark, in the county of Essex and State of New Jersey, have invented certain new and useful Improvements in Screw-Presses; and we do hereby declare the following to be a full, clear, and exact description of the invention, such as will enable others skilled in the art to which it appertains to make and use the same, reference being had to the accompanying drawings, and to letters of reference marked thereon, which form a part of this specification.

Our invention has reference to a novel form of wine-press, and consists of a wine press of the construction and arrangement of parts herein shown.

The invention further consists in certain novel arrangements and combinations of parts, such as will be hereinafter more fully described and finally embodied in the clauses of the claim.

The invention is illustrated in the accompanying sheets of drawings, in which—

Figure 1 is a perspective view of a wine press, embodying the principles of our invention, and Fig. 2 is a vertical section of the press. Fig. 3 is a detail perspective view of a yoke or press-bar employed in the construction of wine press. Fig. 4 is a vertical section of a screw-threaded hub and operative parts connected therewith for causing a pressure upon said yoke or press-bar. Fig. 5 is a top view of certain parts used in connection with said hub, illustrated in Fig. 4; and Figs. 6, 7 and 8 are detail views of the several parts illustrated in said Fig. 4. Fig. 9 is a general perspective view of all the parts comprising the machine.

Similar letters of reference are employed in each of the several views of the drawings to indicate corresponding parts.

In said views, a and a' represent the opposite side pieces of a suitable frame provided with legs or supports a^2 . Said side-pieces a are cut-away, as at a^3 , see Figs. 2 and 9, to form a support for the base-pieces b and b' , each provided with the vertical side-pieces b^2 .

As will be seen, more especially from Fig. 2, said strips a are connected by a cross-piece a^4 , to the under side of which is secured a

suitably shaped stiffening bar a^5 . Said cross-piece a^4 and said stiffening bar a^5 are both provided with a central hole or opening, through which is passed a rod c provided with a screw-threaded end c' . Said rod c is provided at its lower end with a suitably formed plate c^2 having perforations therein through which are passed bolts d , for securing said plate to said stiffening piece a^5 and for securing said parts to the cross-piece a^4 . The heads of said bolts are arranged in suitable recesses in said cross-piece a^4 , as will be clearly seen from Fig. 2.

As has been stated, the base pieces b and b' are supported by said cross-piece a^4 and the recessed portions a^3 in the side pieces a . Each base-piece b and b' is provided with a cut-away portion b^3 whereby said base-pieces are made to fit around the rod c , and the edges of said base pieces are lined with rubber e .

The sides b^2 of each of said base-pieces b and b' are provided in their upper corners with holes b^4 , through which are passed suitable tie-rods f and f' provided with nuts f^2 for firmly drawing the sides b^2 of said base-pieces b and b' against the ends of two other side pieces g and g' , whereby a box is formed, as will be clearly seen from Fig. 1. One of said side pieces g' is provided with an opening or cut-away portion g^2 which is made to fit opposite a groove a^6 in one of the side pieces a' in the frame of the machine.

Secured to suitable strips h and h' are vertically arranged slats i in such a manner as to leave a space i' between two of the adjacent slats. Said slats are preferably made wider at the back than in front, making them wedge-shaped, as will be clearly understood from Figs. 1, 2 and 9. At the ends of said rods h and h' are secured suitable clamping or holding devices h^2 , the one at the one end of the rods being fixed and the other being pivoted and said devices h^2 being provided with recessed holding portions h^3 , forming a hook, and whereby the pivoted holding device can be hooked over and into the recessed portion of the fixed holding device, as will be clearly understood from an inspection of Fig. 9. In this manner a four-sided cage will be the result.

In Fig. 3 is illustrated a yoke or press-bar k provided with a centrally arranged hole k'

and with the cut-away portions k^2 . Connecting the sides k^3 of said cut-away portions k^2 are suitable rods m which form hand-pieces for removing the said yoke or press-bar from the wine-press. Upon the upper surface of said yoke is arranged a perforated plate k^5 which is preferably made of iron.

When the base boards b and b' have been placed in the lower frame of the machine and the sides g and g' have been firmly secured between the sides b^2 of said base-boards, suitable wedges n and n' are placed in openings a' left between the end portions of the side-pieces a and a' of the frame, and said wedges are driven in and against the outer surface of the side b^2 of said base board b' , thereby firmly bringing the rubber edges e of said boards b and b' together, and also bringing said sides b^2 firmly against the ends g^3 of said side-pieces g and g' , making a perfectly liquid tight box or receptacle.

In order to use the press for mashing fruit the cage formed by the bars h and h' and the slats i is placed in this receptacle. The fruit is deposited into this cage and suitable boards l , see Fig. 2, are placed upon the fruit. Upon these boards are placed suitable cross pieces o , o , and o' , o' , in the manner illustrated in Fig. 9, and upon said cross-pieces o' , o' , is placed the yoke or press-bar k , in such a manner that the screw-threaded end c' of the rod c projects from the opening k' in said yoke. Upon said screw-threaded end c' of the rod c is arranged a screw-threaded hub or collar p provided with a knob p' and surrounding the upper edge of said screw-threaded collar p are suitable recesses p^2 . Before said screw-threaded collar p is screwed upon the screw-threaded end of the rod c , it is inserted in the end r' of a sleeve r . Said end r' of said sleeve is chambered, as at r^2 , and is provided with an annular groove r^3 into which said knob p' of said screw-threaded collar p fits, and whereby said sleeve r can be made to turn upon the collar p . In order to get said knob p' into said annular groove r^3 , said chambered portion r^2 of the sleeve r is provided with a groove r^4 , as clearly illustrated in Fig. 6, into which said knob p' on the collar p is placed and passed up therein, until the knob can be turned into said annular groove r^3 . The upper portion of said sleeve r is provided with an opening r^5 which is of greater diameter than the greatest diameter of the screw-threaded end of the rod c . In a rectangular hole r^6 , extending from the top of said sleeve, down into said chambered portion r^2 thereof, is loosely arranged a key s , being of such length that the chamfered end s' of said key fits into one of said recesses p^2 of the sleeve p , as will be clearly seen from said Fig. 4. Thus, when an operating lever t is secured in a hole r^7 of the ear r^8 of said sleeve r and turned in the direction of arrow x , Figs. 1 and 4, the straight side s^2 of the end s' , of said key will turn the screw-threaded nut p upon the screw-threaded end c' of the rod c . By this means,

said sleeve p acts upon the yoke or press-bar k , forcing the boards l tightly down upon the fruit, and the liquor therefrom will flow through the spaces i' between the slats i into the lower receptacle in the frame of the machine, and thence from the opening g^2 into the groove a^6 , as will be evident. When the lever t is turned in the opposite direction, as indicated by the arrow x' , see Fig. 1, then the chamfered edge s^3 of said key s will cause said key to be removed from the recess p^2 in the sleeve p , until it will finally drop into another recess. In this manner the lever t can be worked back and forth in the manner of a ratchet, causing said screw-threaded sleeve p to move downward upon the screw-threaded rod c . In order to cause said screw-threaded sleeve p to move upwardly on the screw c' , all that is necessary is to pull out the key s , reverse its position, and operate the handle or lever t as before.

In the drawings, the press is illustrated as being made of four sides, but of course it will be evident, that any other number of sides may be used.

By the arrangement of the ratchet device illustrated in Figs. 4 and 5, and in detail in Figs. 6, 7 and 8, greater power can be obtained than in the construction of presses as heretofore made, and furthermore, the operator need not walk around the machine, but he may do so if he so desires. By this construction the great advantage is derived, in that the press can be placed in a corner, when cramped for room, the screw-threaded rod c in our form of press being stationary, thereby permitting the use of the ratchet device illustrated in Fig. 4, and thereby overcoming many of the objectionable features in screw-presses, as heretofore made.

Another great advantage is that the several parts of the press can be readily taken apart, rendering the cleaning thereof very easy, and the parts can be packed away in a small space for storing or for shipment.

The box, formed by the sides b^2 , g and g' and the base-boards b and b' , serves the purpose of retaining any skins or other objectionable particles which may have been forced through the spaces i' between the slats i of the cage, and nothing but the pure juice is obtained from the press, free from such objectionable particles.

Having thus described our invention, what we claim is—

1. A press of the class herein set forth, comprising therein a suitable frame, a box or receptacle on said frame, a removably placed cage in said receptacle or box, a fixed screw-threaded rod in said box or receptacle, a perforated yoke or press-bar arranged on said rod, and means for operating said yoke or bar, consisting essentially of a screw-threaded collar p having recesses p^2 , a chambered sleeve r adapted to fit over said collar, and provided with an opening r^6 , a key s therein adapted to engage with said recess p^2 in said collar p ,

and a lever or arm for turning said sleeve r , substantially as and for the purposes set forth.

2. The herein described screw-press, comprising therein, a suitable frame, a box or receptacle on said frame, a removably placed cage in said box or receptacle, a fixed screw-threaded rod in said box or receptacle, a perforated yoke or press-bar k having a hole k' , cut-away portions k^2 at the ends and rods m connecting the sides k^3 of said cut-away portions, and means for operating said yoke or bar, consisting essentially of a screw-threaded collar p having recesses p^2 , a chambered sleeve r adapted to fit over said collar, and provided with an opening r^6 , a key s therein adapted to engage with said recesses p^2 in said collar p , and a lever or arm for turning said sleeve r , substantially as and for the purposes set forth.

3. In a press, the combination, with a suitable frame a screw-threaded rod and a yoke or press-bar on said rod, of a screw-threaded collar p , having recesses p^2 , a chambered sleeve r in which said collar is adapted to rotate, said sleeve being provided with a perforation r^5 and an opening r^6 , a key s in said opening r^6 adapted to engage with said recesses p^2 in said collar p , and means for turning said sleeve r , substantially as and for the purposes set forth.

4. In a press of the class herein set forth, in combination with the frame, consisting of side-pieces a and a' , recessed portions a^3 in said side-pieces a , and having openings a^7 , a box or receptacle, adapted to rest upon said recessed portions a^3 , consisting of base-pieces b and b' , having sides b^2 , separate side pieces g and g' , means for securing said sides together, and wedges n and n' for forcing the base-boards b and b' , tightly together, a fixed screw-threaded rod in said box or receptacle, a perforated yoke or press-bar arranged on said rod, and means for operating said yoke or bar, consisting essentially of a screw-threaded collar p having recesses p^2 , a chambered sleeve r adapted to fit over said collar, and provided with an opening r^6 , a key s therein adapted to engage with said recesses p^2 in said collar p , and a lever or arm for turning said sleeve r , substantially as and for the purposes set forth.

In testimony that we claim the invention set forth above we have hereunto set our hands this 10th day of January, 1894.

FRANK ZWIGARD.
RUDOLF SCHWÖRER.

Witnesses:

FREDK. C. FRAENTZEL,
WM. H. CAMFIELD, Jr.