

A. S. CARDELLA.
HYDRAULIC APPARATUS.
APPLICATION FILED JAN. 17, 1902.

NO MODEL.

2 SHEETS—SHEET 1.

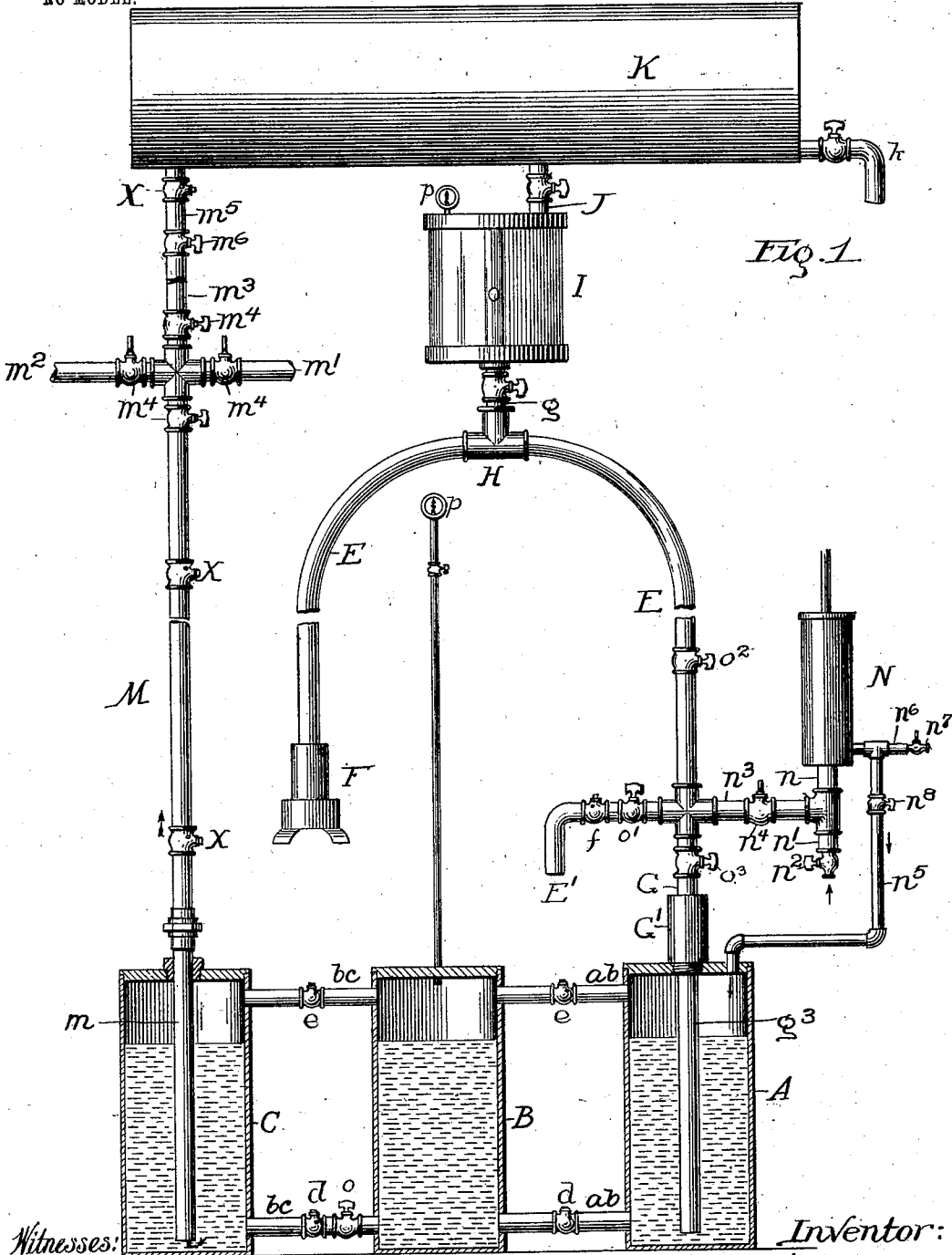

Witnesses:

Chas. Skerwey
S. Bliss.

Inventor:

Alexander S. Cardella
by H. Peters
Atty.

A. S. CARDELLA.
HYDRAULIC APPARATUS.
APPLICATION FILED JAN. 17, 1902.

NO MODEL.

2 SHEETS—SHEET 2.

Fig. 2.

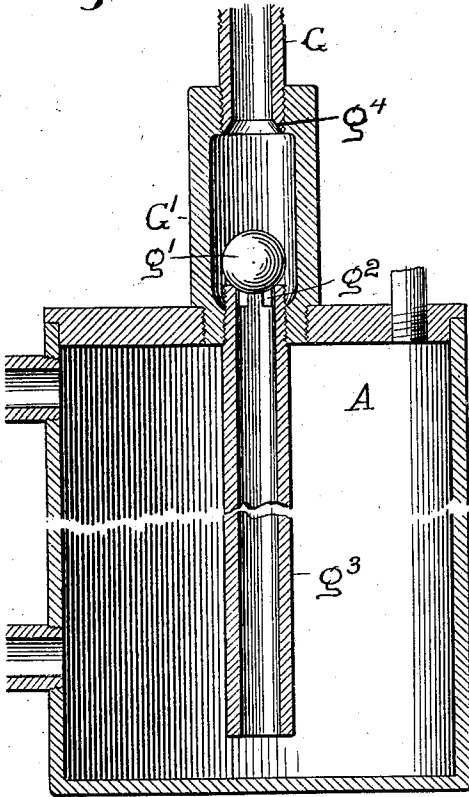

Fig. 3.

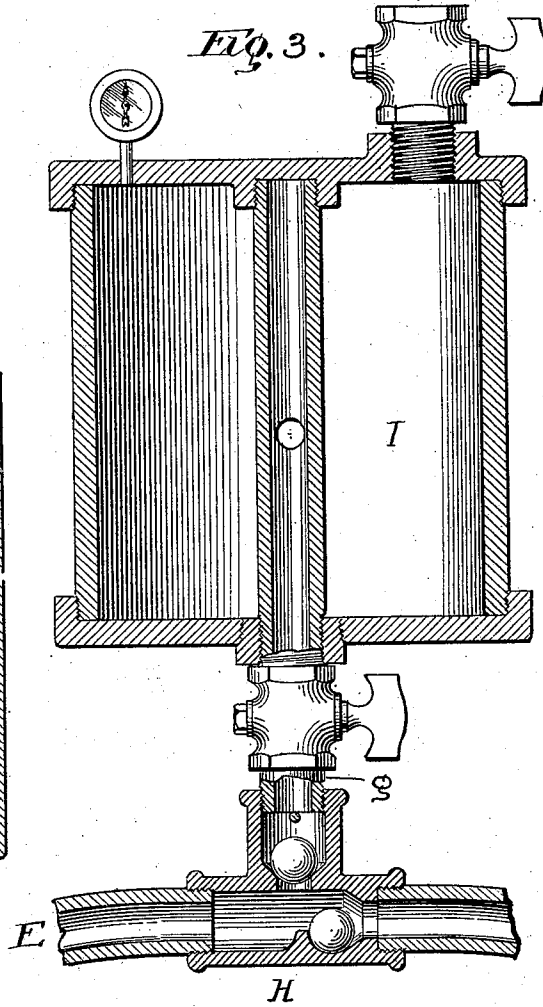
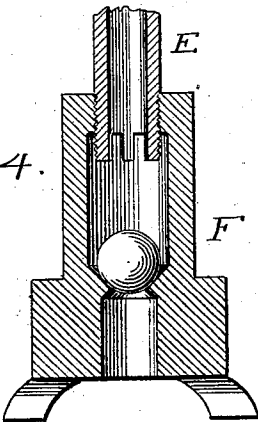

Fig. 4.



Witnesses:
Chas. O. Shurvey
S. Bliss.

Inventor:
Alexander S. Cardella
by H. Pitner.
Atty.

UNITED STATES PATENT OFFICE.

ALEXANDER S. CARDELLA, OF CHICAGO, ILLINOIS, ASSIGNOR OF ONE-HALF
TO WILLIAM H. WALLIS, OF CHICAGO, ILLINOIS.

HYDRAULIC APPARATUS.

SPECIFICATION forming part of Letters Patent No. 718,424, dated January 13, 1903.

Application filed January 17, 1902. Serial No. 90,117. (No model.)

To all whom it may concern:

Be it known that I, ALEXANDER S. CARDELLA, a citizen of the United States of America, residing at Chicago, in the county of Cook and State of Illinois, have invented certain new and useful Improvements in Hydraulic Apparatus, of which the following is a specification.

My invention relates to certain improvements in hydraulic apparatus, the object of which is to provide means whereby water or other liquid may be made accessible at different elevations and points in the apparatus without an equal elevation or head of water, as is customary in the ordinary systems of water distribution.

To such end the invention consists in certain novel combinations and arrangement of elements, which will fully appear from the description and the essential characteristics of which will be pointed out in the claims.

In the drawings, Figure 1 is a general elevation of an apparatus illustrating my improvements. Fig. 2 is a diametrical longitudinal section of one of the check-valves and reservoirs. Fig. 3 is a similar section of a double siphon-valve and parts connected therewith, and Fig. 4 is a similar section of the siphon foot-valve.

Referring to the drawings, A B C are a series of reservoirs connected by pipes *a b*, *b c*, preferably containing check-valves *d e*, working in the proper direction to permit of the passage of water from A to B and from B to C. These reservoirs are placed at a convenient level sufficiently low to enable water to be run into them by gravity or by other suitable means—as, for instance, by the siphon E, the foot-valve of which, F, is placed in a convenient reservoir or natural source of supply and the discharge end of which, G, empties into the reservoir A. The construction of the foot-valve F is illustrated in Fig. 4, and it is made in the form of a gravity check-valve, permitting flow through it in the proper direction for the working of the siphon, but preventing return of the liquid which has passed it. I have shown as interposed in the neck of the siphon a combined check and momentum valve H, the momentum-valve clos-

ing by the rush of the water through the siphon and the check-valve permitting escape of the water when the flow is interrupted, said escape leading upward into a pipe *g*, leading to a cylinder-casing I, the sides of which are glass to disclose the interior, said casing being connected by a pipe J with an elevated tank K.

The combined check and momentum valve is fully described in a pending application of mine, Serial No. 49,536, to which reference is made for a description of the details of the valve.

At the point where the siphon empties into the reservoir A an upwardly-closing check-valve G' is provided, the construction of which is illustrated in Fig. 2, the valve-seat being at *g*⁴ and a ball-valve *g*¹ being adapted to seat upwardly and preferably having a specific gravity less than the liquid to be handled, so that when the valve is filled the normal position of the ball will be at the top. The lower portion of the casing is cut away to form by-passes *g*² to prevent the ball from closing the valve downwardly when the casing is empty. From this check-valve G' an extension-pipe *g*³ reaches nearly to the bottom of the reservoir A, and a similar pipe *m* in the reservoir C connects with a distribution-pipe M, provided with suitable branches *m*¹ *m*² *m*³, leading to the desired points of delivery and all containing suitable stop-cocks or faucets *m*⁴, by means of which the pipes may be closed except when water is desired to flow through them. These distribution-pipes may be connected, as by the pipe *m*⁵, with the elevated tank K, so as to permit the water from said tank to be utilized in the system, if desired, and a stop-cock *m*⁶ is interposed to shut off the tank when delivery at a higher elevation is desirable. A stop-cock *k* provides means for drawing the water from the tank K.

An air pump and compressor is shown at N and has an intake-pipe *n*, opening by a branch *n*¹ to the atmosphere, said branch being provided with a stop-cock *n*² and also connected by means of a branch pipe *n*³ with the siphon E, a stop-cock *n*⁴ being provided to disconnect the pump from the siphon when desired. The discharge-pipe of the pump *n*⁵ leads to

the top of the reservoir A and has a branch n^6 open to the atmosphere, this branch and the pipe leading to the reservoir A being controlled by stop-cocks n^7 n^8 , respectively, so
 5 that the pump may discharge either into the atmosphere or compress air into the cylinder A.

The particular form of the pump is immaterial, and it may be operated by hand or by
 10 power, as may be desired.

By opening the stop-cocks n^4 n^7 and closing n^2 n^5 the pump may be used to draw the air from the siphon and discharge it into the atmosphere and in this way start the siphon
 15 to working. When the siphon is started, the stop-cock n^4 should be closed, after which the water will flow through the siphon into the reservoirs A B C. During this operation the stop-cocks n^7 n^8 should be open to permit of
 20 the escape of the air from the reservoirs. The flow of water into the reservoir will incidentally effect the raising of a quantity of water through the pipe J into the tank K, and the glass casing I affords means for determining whether this part of the apparatus
 25 is working properly. After the reservoirs are full, the stop-cock n^7 should be closed and n^2 open, after which the air-pump is utilized to force air into the reservoirs, closing the check-valve G' against the return of the water
 30 through the siphon and filling the system of distribution-pipes if the same happen to be empty. Except in the initial working of the apparatus the distribution-pipes will normally be filled to the level of the lowest discharge-opening because of the presence of
 35 check-valves X, which prevent the return of water to the reservoirs. As soon as the distribution-pipes are filled air may be forced into the cylinders and compressed to any desired degree, affording a constant power sufficient to discharge the water from any of the faucets in the distribution-pipes. As soon as
 40 the tanks are empty the compressed air may be allowed to escape through the pipes n^5 n^6 and the operation repeated indefinitely.

A stop-cock o is shown in the lower pipe b c , which connects the reservoirs B C to shut off the flow through said pipe when this is desirable. The longer end G of the siphon may be provided with a second intake-pipe E', in
 50 which are interposed a check-valve f , opening toward the branch G, and a stop-cock o' . The second intake-pipe E' has a downwardly-extending end and connects with the main siphon, so as to form a second or auxiliary siphon, the inlet of which is somewhat below
 55 the inlet of the main siphon, thereby adapting the same to operate in case the level of the water falls below the intake of the main siphon. Similar stop-cocks o^2 o^3 are interposed in the branch G on either side of the joint between the pipes E' n^3 .

The reservoir B and tank I are each provided with a pressure-indicator p to show the pressure contained within.

The apparatus once charged will be at all

times ready for use, and water may be drawn from any of the various branch pipes as it is needed.

I recognize the possibility of variation in detail and for that reason do not consider my invention to be limited to the specific construction.

I claim as new and desire to secure by Letters Patent—

1. In a hydraulic apparatus, the combination with a siphon, of a reservoir into which the longer end of the siphon empties, an elevated tank connected to said reservoir, a pump connected to the longer end of the siphon and to the reservoir, operating to create suction upon the longer end of said siphon, and to force air into the reservoir, and suitable means for closing the communication between the pump and the siphon and the pump and the reservoir, substantially as described.

2. In a hydraulic apparatus, the combination with a siphon, a reservoir into which the longer end of the siphon empties, and an elevated tank connected to said reservoir, of a combined check and momentum valve in the neck of said siphon connected to said elevated tank and operating to deliver a portion of the water flowing through the siphon to said elevated tank and means for supplying said reservoir with compressed air, when the same becomes filled, for raising the water contained therein into the elevated tank, substantially as described.

3. In a hydraulic apparatus, the combination with a siphon having a check-valve at its shorter end opening upward and a stop-cock in its longer end, of a reservoir into which the longer end of the siphon empties, an elevated tank connected to said reservoir, a suitable pump connected to the longer end of the siphon, a pipe connecting the pump with the reservoir, and a stop-cock therein, said pump being adapted to produce suction upon the longer end of the siphon for the initial starting of the same when the stop-cock therein is open and to supply compressed air to the reservoir for raising the water contained therein to the elevated tank when the stop-cock in the pipe connecting the pump with the reservoir is open, substantially as described.

4. In a hydraulic apparatus, the combination with a siphon having a check-valve opening upward at its intake and a check-valve at its outlet opening downwardly, of a reservoir into which the longer end of said siphon empties, an elevated tank connected thereto, a pump operating to create suction upon the longer end of the siphon or to supply compressed air to the reservoir; substantially as described.

5. In a hydraulic apparatus, the combination with a siphon having a check-valve in its longer end opening downward, of a reservoir into which the longer end of said siphon empties, an elevated tank connected to said reservoir, a pump, N, a pipe connecting said pump with the longer end of the siphon, a

pipe connecting the pump with the reservoir, and stop-cocks in said pipes for closing communication between the pump and siphon or reservoir; substantially as described.

5 6. In a hydraulic apparatus, the combination with a siphon having check-valves at its intake and its outlet, opening upward and downward respectively, of a reservoir into which the longer end of the siphon empties, 10 a series of reservoirs approximately on a level with the first-named reservoir, pipes connecting one with the other, check-valves interposed in said pipes opening in a direction away from the first-named reservoir, an 15 elevated tank, a pipe connecting the last reservoir of the series with said tank, a series of check-valves in said pipe, and means for supplying compressed air to the first-mentioned reservoir, substantially as described.

20 7. In a hydraulic apparatus, the combination with a siphon emptying into a suitable reservoir, an elevated tank connected thereto, a pump, N, a pipe connecting the same with the longer end of the siphon, a stop-cock, n^4 , 25 interposed therein, an air-cock, n^2 , interposed in said pipe between the stop-cock, n^4 , and the pump, and opening to the atmosphere, a second pipe, n^5 , connecting the pump with the reservoir, a stop-cock, n^8 , therein, an air-cock, n^7 , interposed between the stop-cock, n^8 , 30 and the pump and opening to the atmosphere, whereby the pump may operate to create suction upon the end of the siphon when the stop-cock, n^7 , is open and the stop-cock, n^2 , closed, or may supply compressed air to the reservoir when the stop-cock, n^7 , is closed, and the stop-cock, n^2 , is opened, 35 substantially as described.

40 8. In a hydraulic apparatus, the combination with a siphon having an upwardly-open-

ing check-valve in its shorter end, a downwardly-opening check-valve in its longer end and a combined check and momentum valve in its neck, opening upward, of an elevated 45 tank connected to said combined check and momentum valve, a reservoir into which the longer end of the siphon empties, connected to said elevated tank, a pump and suitable 50 controlling devices connecting said pump with the longer end of the siphon and with the reservoir, said pump operating to create suction on the longer end of the siphon or to supply compressed air to the reservoir for raising the water contained in the same, sub- 55 stantially as described.

9. In a hydraulic apparatus, the combination with a siphon, a reservoir in which the longer end of the siphon empties, a second 60 intake branch interposed in the longer end of the siphon, having a downturned end, the inlet of the shorter end of the main siphon, said second intake branch forming, together with the longer end of the main siphon, an 65 auxiliary siphon, a check-valve, f , and stop-cock, o' , in said second intake branch, and a stop-cock, o^2 , in the longer end of the main siphon above the second intake, whereby, 70 when the level of the water falls below the main intake, the auxiliary siphon may be employed to siphon the water, substantially as described.

In witness whereof I have hereunto set my hand, at Chicago, in the county of Cook and State of Illinois, this 13th day of January, 75 A. D. 1902.

ALEXANDER S. CARDELLA.

Witnesses:

CHARLES O. SHERVEY,
S. BLISS.