



INTERNATIONAL APPLICATION PUBLISHED UNDER THE PATENT COOPERATION TREATY (PCT)

<p>(51) International Patent Classification ⁵ : G07F 17/34</p>	<p>A1</p>	<p>(11) International Publication Number: WO 91/03034 (43) International Publication Date: 7 March 1991 (07.03.91)</p>
--	------------------	---

(21) International Application Number: PCT/GB90/01256
 (22) International Filing Date: 10 August 1990 (10.08.90)
 (30) Priority data:
 8918448.5 12 August 1989 (12.08.89) GB
 (71) Applicant (for all designated States except US): BELL-FRUIT MANUFACTURING COMPANY LIMITED [GB/GB]; Leen Gate, Lenton, Nottingham NG7 2LX (GB).
 (72) Inventor; and
 (75) Inventor/Applicant (for US only): HOWARD, Terence [GB/GB]; 12 Mosswood Crescent, Bestwood Park, Nottingham NG5 5SW (GB).
 (74) Agent: BARKER, BRETTELL & DUNCAN; 138 Hagley Road, Edgbaston, Birmingham B16 9PW (GB).

(81) Designated States: AT (European patent), AU, BE (European patent), CH (European patent), DE (European patent)*, DK (European patent), ES (European patent), FR (European patent), GB, GB (European patent), IT (European patent), JP, LU (European patent), NL (European patent), SE (European patent), US.

Published
 With international search report.

(54) Title: GAMING AND AMUSEMENT MACHINES AND REELS FOR THEM

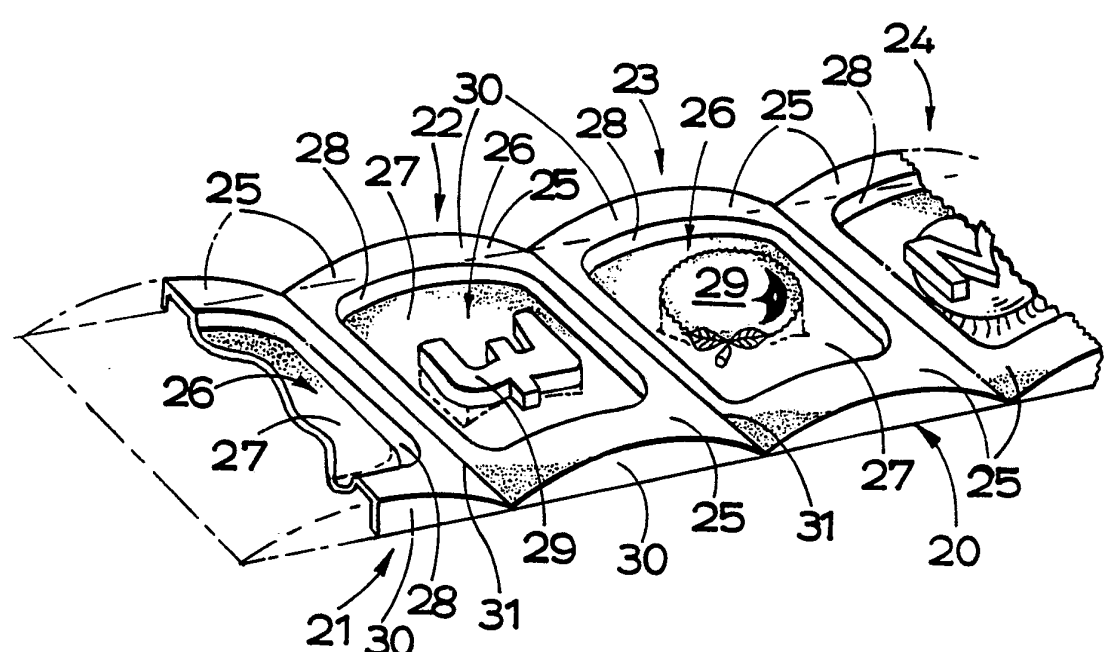

(57) Abstract

A reel for a gaming or amusement machine of the type commonly known as a fruit machine, has a reel-strip (1) which has symbols (2) at least partially within sunken regions (26) of the reel strip. The symbols (2) may be formed in relief in the sunken regions but do not project above a frame (25) which surrounds the sunken regions (26). The surface of the frame may be arcuate, such that the reel is cylindrical in shape, or flat, such that the reel is polygonal.

* See back of page

DESIGNATIONS OF "DE"

Until further notice, any designation of "DE" in any international application whose international filing date is prior to October 3, 1990, shall have effect in the territory of the Federal Republic of Germany with the exception of the territory of the former German Democratic Republic.

FOR THE PURPOSES OF INFORMATION ONLY

Codes used to identify States party to the PCT on the front pages of pamphlets publishing international applications under the PCT.

AT	Austria	ES	Spain	MC	Monaco
AU	Australia	FI	Finland	MG	Madagascar
BB	Barbados	FR	France	ML	Mali
BE	Belgium	GA	Gabon	MR	Mauritania
BF	Burkina Fasso	GB	United Kingdom	MW	Malawi
BG	Bulgaria	GR	Greece	NL	Netherlands
BJ	Benin	HU	Hungary	NO	Norway
BR	Brazil	IT	Italy	PL	Poland
CA	Canada	JP	Japan	RO	Romania
CF	Central African Republic	KP	Democratic People's Republic of Korea	SD	Sudan
CG	Congo	KR	Republic of Korea	SE	Sweden
CH	Switzerland	LI	Liechtenstein	SN	Senegal
CM	Cameroon	LK	Sri Lanka	SU	Soviet Union
DE	Germany	LU	Luxembourg	TD	Chad
DK	Denmark			TG	Togo
				US	United States of America

GAMING AND AMUSEMENT MACHINES AND REELS FOR THEM

This invention relates to gaming and amusement machines and in particular to those commonly known as fruit machines. In such machines a number of reels, usually three or four, carrying symbols on their peripheries are spun and then stopped at random. If they come to a halt with any one of a number of selected combinations of symbols on a so-called 'win line', an award is made or other equivalent benefit is obtained. Such a machine will hereinafter be referred to as of the kind set forth.

Traditionally these reels have been mechanical, rotating side by side on a common axis and with the symbols carried on their peripheral cylindrical surfaces. This is almost universal although in certain countries, e.g. Germany, the reels are sometimes in the form of flat discs with the symbols arranged in a ring on one face. Even an arrangement involving each reel being in the form of a frustum of a cone, with the peripheries lying in a common conical surface, is known.

Attempts have been made to get away from the simple printed representation of the symbols, usually fruit such as plums, cherries, oranges and so on, and it has been proposed to project the symbols optically in turn onto a flat translucent screen, the so-called Panascope system. We have ourselves proposed to use a video screen on which an electrically generated image of the rotating reels is displayed. However these alternatives lack the contrast and brightness of a colour-printed two-dimensional picture of the symbol and so there has lately been a reversion to the mechanical reels with the symbols on their peripheries.

It has been proposed, in GB 2 183 883 A, to provide gaming and amusement machines with symbols formed in relief, i.e. in three-dimensions, on the periphery of the reel so that they stand out from the surface of the reel.

The general outline of the use of such symbols in relief is described in GB 2 183 833 A, and the functional advantages of the such use is intimated. The ability, for example, to recognise the symbols rapidly is enhanced, which improves the user's perception of the game, and the recognition in particular of symbols further round the periphery of the reel (away from the winline) allows the machine to be constructed so that certain game sub-features (such as nudging, for example) are possible under conditions in which, with conventional flat-printed reel strip symbols, they would not otherwise be practicable.

Suggested methods of forming symbols in relief, which conventionally would be fruit symbols but could be in other forms as required by the game, have, up to now, been based upon the symbol concerned being raised from the surface of a flat reel-strip base material, such that the material forming the reel-strip at any point on the embossed or raised area is situated at a greater radius than that of the base material. There is a severe disadvantage of this approach which has become apparent in practice, however, in that the base material must conform to the surface of the reel drum in order to be mounted accurately to it; the reel drum, being a rotated component, needs to be symmetrical (i.e. cylindrical), and hence the surface onto which the reel-strip base material is fitted is also cylindrical. In current art, it is known that the reel drum does not need to be a complete surface, and that

large parts of its area can be beneficially removed to conserve weight (and hence reduce inertia) and material content; however, the reel-strip material itself still has to conform to the cylindrical outline of that part of the reel drum remaining, particularly along the outside rim of the drum which is the main reel-strip supporting element. The disadvantage of the relief or embossing method as described above is that the reel-strip material deforms under the process for forming the symbols in relief, and when wrapped around the reel drum tends to form a series of inaccurate straight edges at parts of the strip containing the symbols in relief, and curves of sharper than required radius at points where there are no such symbols in relief. The amount to which such distortion occurs is not easily predictable and depends to a certain extent on the shape of the particular symbol. This inaccuracy makes the reel-strip difficult to fit, and also the lack of precise control in the exact shape of the edges of the reel-strip make the risk of fouling on the reel drum-supporting components likely.

Also, conventional reel drums are usually rotated by an electrically driven motor, for instance a stepper motor, and in order to lessen the dynamic load on the motor driving the rotating parts of the reel assembly, it is usual to remove any unnecessary material from the drum, whilst still retaining a rim to provide circumferential attachment for the reel-strip; the conventional reel-strip not being of any significant structural strength.

According to a first aspect of the invention there is provided a reel strip for a gaming or amusement machine having a first surface adjacent a sunken region

provided below the level of the first surface, and a symbol, or fruit, displayed at the sunken region.

5 The sunken region gives the strip a three-dimensional profile and increases its strength. There may be separate sunken regions for each symbol or fruit, the sunken regions drawing the attention of the user to the fruit.

10 Preferably there are a plurality of sunken regions.

The first surface preferably extends at least partially around the or each sunken region.

15 The symbols may be two-dimensional, e.g. by being printed onto the material of the strip within the surrounding regions, but preferably they are formed in relief so that they stand out from the sunken surrounding regions. A mixture of 2-D and 3-D symbols
20 may be provided.

When the symbols are formed in relief, preferably they are formed to a maximum height so that the height of the outermost part of each symbol above its sunken
25 surrounding region does not exceed the height of the raised sections of the reel-strip.

The raised sections of the reel-strip and the sunken regions surrounding the symbols thus form a
30 "frame" for each symbol which imparts to the reel-strip an accurately-defined shape, irrespective of the profile of and degree of relief imparted to the fruit symbol itself. The reel-strip itself is thereby an accurately reproducible component and its fitting to
35 the periphery of the reel drum is greatly eased, as are

any potential problems of fouling with other parts of the assembly.

5 The frame may be shaped such that the reel has an overall cylindrical shape. However, in certain reel arrangements, it may be advantageous for the reel to be substantially polygonal. In this case, the frames are arranged to be flat with bends being formed between adjacent frames.

10 The reel in accordance with the invention may comprise a conventional rotatable reel drum element with the novel form of reel-strip attached around its outer periphery.

15 Alternatively, instead of a conventional reel drum element the support element for the reel-strip may be of skeletal form, for example comprising two circular members of the same diameter connected at regular circumferentially spaced intervals by transverse cross-members, with radial spokes extending from the cross-members to the centre of the reel. In an alternative version there need be only one circular member having projecting support members.

20
25 In this type of reel assembly it is a relatively simple matter to attach the reel strip to the support element with the sunken regions surrounding the symbols being positively and accurately located in the spaces between the transverse cross-members. It is difficult to achieve such accurate location with a flat reel-strip or with a reel-strip with embossed symbols standing out from the outer surface of the strip.

30
35 Furthermore, the reel-strip with its configuration of raised sections and sunken regions surrounding the

symbols possesses sufficient structural properties to render the use of the reel drum or other support element unnecessary. A reel-strip which has 3-D profiled symbols in its sunken regions is particularly strong. The advantage of this is that it reduces the cost of the reel assembly, reduces the number of individual parts, reduces use of material and also reduces the need for expensive investment in mould tooling, as the tooling costs for the relief forming reel-strips are substantially less, if for example vacuum forming techniques are used, than those of an injection-moulding tool for an entire reel drum. In this case the drive part of the reel mechanism assembly may consist of a drive spindle fitted with a "spider" arrangement, to the ends of the arms of which would be affixed a reel-strip in accordance with the first aspect of the invention. The cylindrical form of the reel would be defined by the reel-strip itself, which although still consisting of thin plastic material would have structural integrity imparted to it by its form.

The reel-strip as described above in accordance with the first aspect of the invention thus gives benefits in the fitting of the reel-strip to the reel drum or other reel-strip support element, in the reduction of the possibility of fouling on other components during rotation in the positive location of its position around the periphery, and in the opportunity to save material in the reel assembly. This is particularly so of reel-strips having profiled fruit.

A possible production method for such reel-strips may be based on conventional vacuum-forming equipment, using raised relief moulds for the symbol "frames" and

for the symbols themselves. In current practice, the variety of fruit or other symbols in common use is fairly restricted, to between possibly ten and twenty over all in machines in production at any one time. In
5 the fabrication of moulds to form such reel-strips, therefore, a technique in which the symbol "frames" are standard to all machines and the different arrangements of fruit or other symbols required for an individual machine could be made up by the use of mould inserts in
10 the relevant positions could be used.

According to a second aspect the invention comprises a reel having a reel-strip in accordance with the first aspect of the invention.

15

According to third and fourth aspects the invention comprises a gaming or amusement machine having a reel-strip in accordance with the first aspect of the invention or a reel in accordance with the
20 second aspect of the invention.

Some embodiments of the present invention will now be described, by way of example only, with reference to the accompanying drawings in which:

25

Figure 1 is a sketch view showing in profile a known type of reel-strip attached to a reel drum of a fruit machine;

30

Figure 2 is a side sectional view of a curved reel-strip in accordance with the invention;

Figure 3 is a front view of the reel-strip of Figure 2;

35

Figure 4 is a side sectional view of the strip of Figures 2 and 3 in flat form;

5 Figure 5 is a front view of a support element for the reel-strip of Figures 2 to 4;

10 Figure 6 is a sectional view showing a reel-strip in accordance with the invention mounted on the support element of Figure 5;

Figure 7 shows another reel-strip in accordance with the invention in a flat configuration; and

15 Figure 8 shows the reel-strip of Figure 7 in its configuration of use.

20 Figure 1 shows a known type of reel-strip 1 having embossed symbols 2 formed in relief which stand out from the surface of the strip. The strip 1 is attached to the outer periphery of a conventional reel drum 3. The strip with embossed symbols 2 of this form, however, suffers from the disadvantage that the reel-strip material deforms under the embossing process and consequently the reel-strip does not fit very well
25 onto the reel drum 3 and there is a risk of fouling during rotation.

30 The reel-strip shown in Figures 2 to 4 may be formed from thin plastics sheet material and has raised sections 4 and a plurality of symbols 5 formed in relief surrounded by sunken surrounding regions 6. As shown in Figure 4 the reel-strip may initially be made in flat form before it takes up its curved position in use as part of a fruit machine reel. In its flat form,
35 the borders 7 of the reel-strip may bulge slightly above the raised sections 4 but in its curved

form (Figure 2) they will normally have the same radius from the centre of the reel as the raised sections 4 between the symbols 5 and their surrounding sunken regions 6.

5

In an alternative arrangement, the borders 7 of the reel strip may be formed such that they are flat when the reel strip is curved around a drum reel. In this case, bends, or lines of weakness are formed at the boundaries between adjacent symbol frames 5 to ensure that the reel is very nearly polygonal and does not bulge outwards near the centre of a frame.

10

It will be appreciated that the symbols 5 have a maximum height above their surrounding regions 6 such that when the strip forms at least part of a reel assembly, the radius of the outermost surface of the fruit symbols 5 does not exceed the rotational radius of the front of the reel constituted by the raised sections 4 and the borders 7 of the strip.

15

20

Another embodiment of the first aspect of the invention is shown in Figures 7 and 8. Figure 7 shows a moulded plastics reel-strip 20 having adjacent segments 21, 22, 23 and 24 in a flat configuration. The strip 20 is a vacuum moulded thin plastics component, each segment comprises a part-cylindrical frame surface 25, a recess 26, a base surface 27 of the recess, side surfaces 28 of the recess, a relief symbol 29 standing proud of the base surface 27, and two opposed spaced side walls 30. A line of flexing, or weakness 31 is provided between the adjacent frame surfaces 25 of adjacent segments.

25

30

The symbols 29 project above the respective base surfaces 27 to an extent which is not more than the

35

depth of the recess, thus staying at or below the level of the respective frame surfaces 25. The symbols 29 may have a substantially flat upper surface, such as the pound symbol of segment 22, or a dimpled or profiled surface such as the orange of segment 23. A number may be moulded with the symbol (see segment 24).

The side walls 30 are segments of a circle and when the strip 20 is in use (see Figure 8) the frame surfaces 25 lie in a common cylinder, with the side walls 25 being segments of a first or a second circle (depending upon which side of the segments the walls are provided).

The reel-strips of Figures 2 to 4 and 7 and 8 can be mounted readily on a support element of skeletal form having ring members 8 connected at regular intervals by transverse cross-members 9 (Figures 5 and 6). In this arrangement the sunken surrounding regions 6 which "frame" the symbols 5 can be positively located between the cross-members 9, thus locating accurately the position of the symbols on the support element. The support element need have only one ring provided with transverse support members, and/or could comprise a dished plate.

The reel-strips of Figures 2 to 4 and 7 and 8 can also be mounted by means of one, or two spaced, ring members provided at an edge of the strip, the ring members defining a channel in which the edge (or edges) of the strip is received. The edge of the strip may have a flange provided for location in such a channel; for example the strip 20 of Figures 7 and 8 could have a flange projecting outwards at right angles to the side walls 30.

CLAIMS

1. A reel strip for a gaming or amusement machine having a first surface (25) adjacent a sunken region (26) provided below the level of the first surface, and a symbol (2), or fruit, displayed at the sunken region.
2. A reel strip according to claim 1, characterised in that it has a plurality of sunken regions (26) at which symbols, or fruit, are displayed.
3. A reel strip according to claim 1 or claim 2, characterised in that the first surface extends at least partially around the or each sunken region.
4. A reel strip according to any one of claims 1 to 3, characterised in that at least some of the symbols are formed in relief at the sunken regions.
5. A reel strip according to claim 4, characterised in that the symbols (2) which are formed in relief project from the sunken region (26) to a height not substantially greater than that of the first surface (25).
6. A reel strip according to any preceding claim, characterised in that it is formed from a plurality of segments interconnected so as to permit the strip to flex along the lines of interconnection.
7. A reel strip according to claim 6, characterised in that each segment has a portion of the first surface and a sunken region.
8. A reel strip according to any preceding claim, characterised in that the first surface comprises a

frame surface extending around the or each sunken region.

5 9. A reel strip according to any preceding claim, characterised in that it comprises a plurality of segments each having a frame surface substantially surrounding a sunken region, the segments being interconnected at lines of flexure, the frame surfaces being parts of cylindrical arcs with the axes of
10 curvature being at right angles to the length of the strip so that when the strip is curved around support means (8, 9) to form a reel the frame surfaces lie on a common cylindrical surface.

15 10. A reel strip according to claim 9, characterised in that the frame surfaces are flat instead of being parts of a cylindrical surface, the strip forming a polygon when it is curved around support means to form a reel.

20 11. A reel strip according to any preceding claim, characterised in that each sunken region has a three-dimensional profiled symbol.

25 12. A reel strip according to any preceding claim, characterised in that it is made of plastics material.

30 13. A reel for a gaming or amusement machine comprising support means (8, 9) holding a reel-strip (1; 20), characterised in that the reel-strip is in accordance with any one of claims 1 to 12.

35 14. A reel for a gaming or amusement machine according to claim 13, characterised in that the support means supports the strip at spaced apart locations, the strip being unsupported between said locations, and in that

13

the strip has enough structural rigidity to maintain the shape of the reel.

15. A gaming or amusement machine, characterised in
5 that it incorporates a reel strip in accordance with any one of claims 1 to 12.

16. A gaming or amusement machine, characterised in
10 that it incorporates a reel in accordance with claim 13 or claim 14.

15

20

25

30

35

1/3

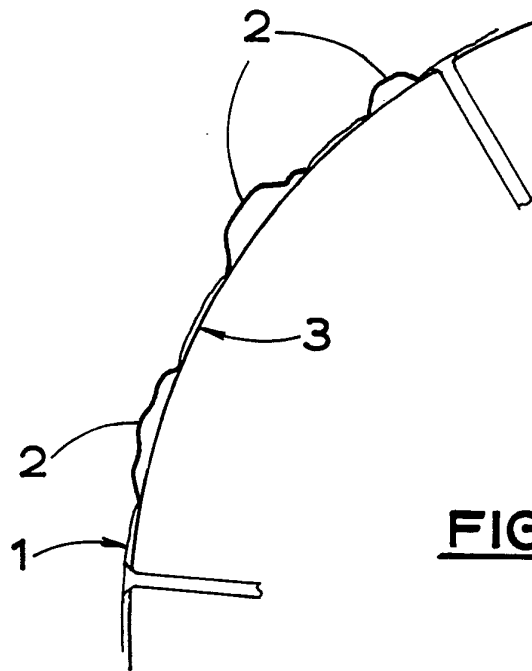

FIG. 1. PRIOR ART.

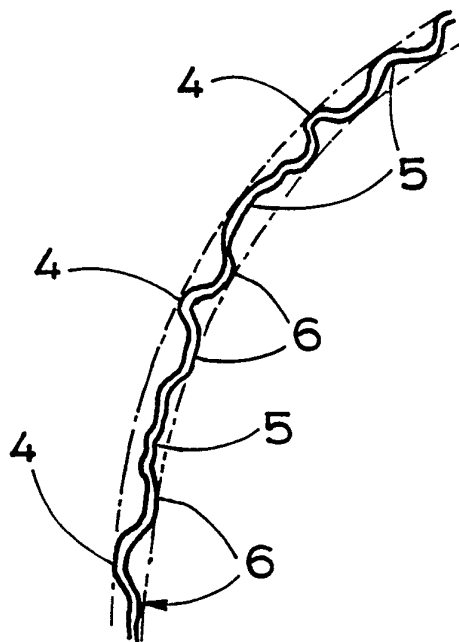

FIG. 2.

SUBSTITUTE SHEET

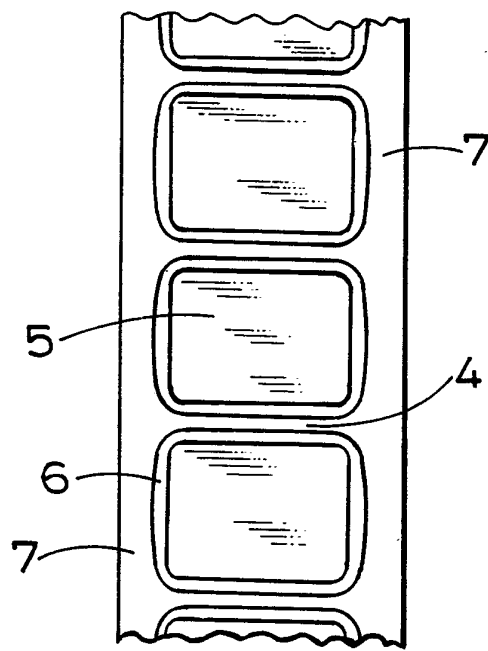

FIG. 3.

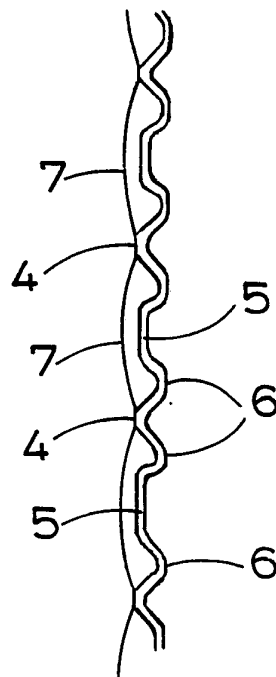

FIG. 4.

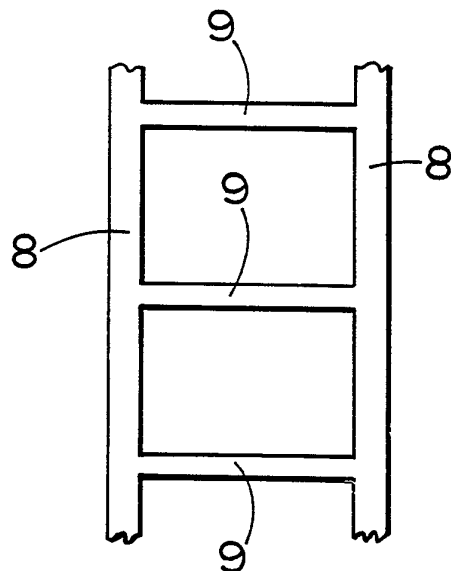

FIG. 5.

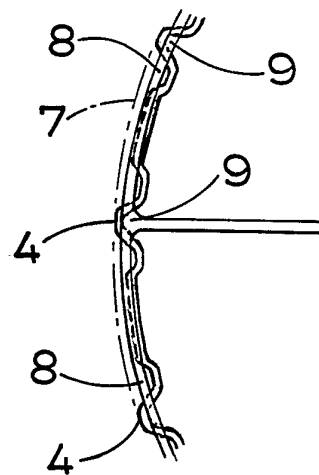

FIG. 6.

3/3

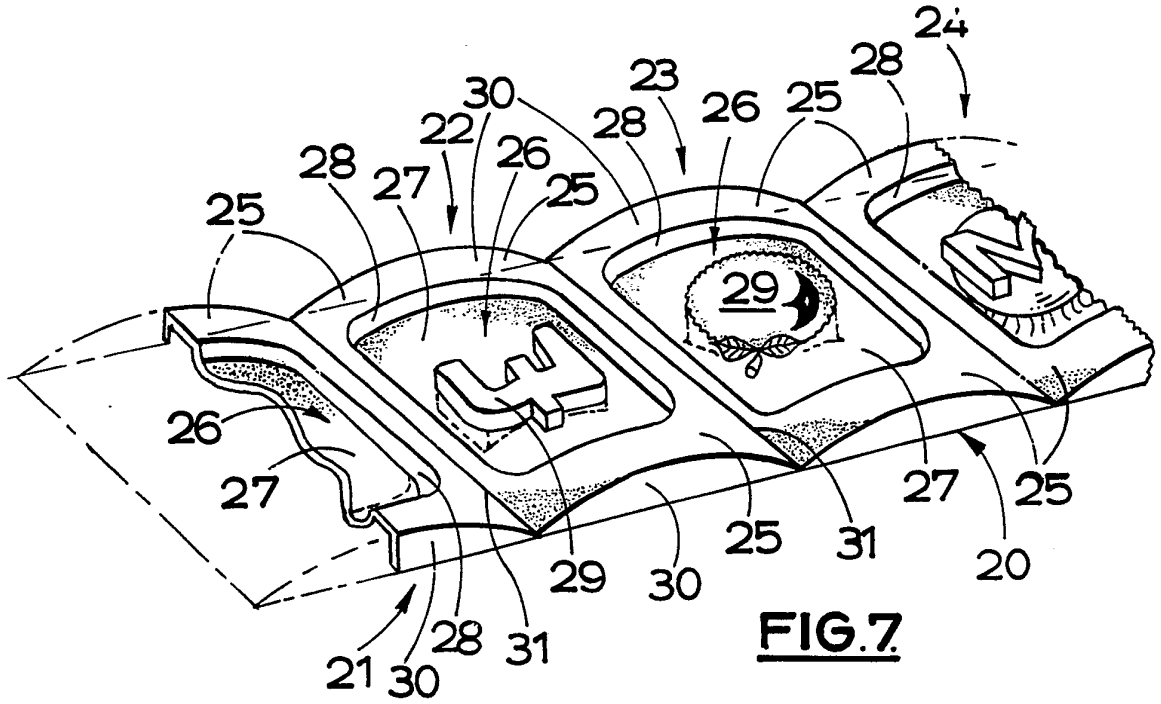

FIG. 7.

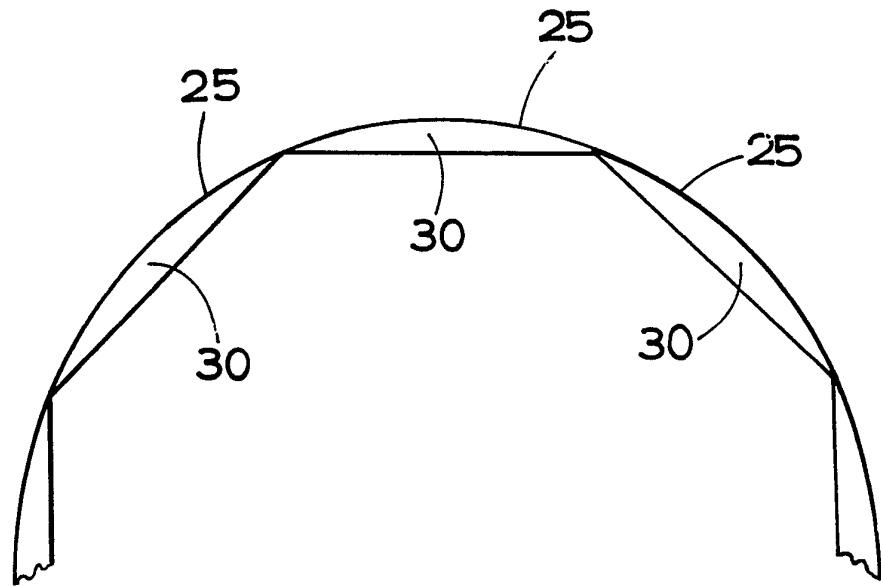



FIG. 8.

INTERNATIONAL SEARCH REPORT

PCT/GB 90/01256

International Application No.

I. CLASSIFICATION OF SUBJECT MATTER (if several classification symbols apply, indicate all) ⁶				
According to International Patent Classification (IPC) or to both National Classification and IPC Int.Cl. 5 G07F17/34				
II. FIELDS SEARCHED				
Minimum Documentation Searched ⁷				
Classification System	Classification Symbols			
Int.Cl. 5	G07F			
Documentation Searched other than Minimum Documentation to the Extent that such Documents are Included in the Fields Searched ⁸				
III. DOCUMENTS CONSIDERED TO BE RELEVANT⁹				
Category ^o	Citation of Document, ¹¹ with indication, where appropriate, of the relevant passages ¹²	Relevant to Claim No. ¹³		
A	GB,A,2183883 (BELL-FRUIT MANUFACTURING COMPANY) 10 June 1987 see the whole document (cited in the application) ---	1, 13, 15		
A	US,A,2545644 (A.C. BENTON) 20 March 1951 ---			
A	FR,A,463669 (APPAREILS AUTOMATIQUES BUSOZ) 02 March 1914 ---			
<table style="width: 100%; border: none;"> <tr> <td style="width: 50%; border: none; vertical-align: top;"> ^o Special categories of cited documents :¹⁰ "A" document defining the general state of the art which is not considered to be of particular relevance "E" earlier document but published on or after the international filing date "L" document which may throw doubts on priority claim(s) or which is cited to establish the publication date of another citation or other special reason (as specified) "O" document referring to an oral disclosure, use, exhibition or other means "P" document published prior to the international filing date but later than the priority date claimed </td> <td style="width: 50%; border: none; vertical-align: top;"> "T" later document published after the international filing date or priority date and not in conflict with the application but cited to understand the principle or theory underlying the invention "X" document of particular relevance; the claimed invention cannot be considered novel or cannot be considered to involve an inventive step "Y" document of particular relevance; the claimed invention cannot be considered to involve an inventive step when the document is combined with one or more other such documents, such combination being obvious to a person skilled in the art. "&" document member of the same patent family </td> </tr> </table>			^o Special categories of cited documents : ¹⁰ "A" document defining the general state of the art which is not considered to be of particular relevance "E" earlier document but published on or after the international filing date "L" document which may throw doubts on priority claim(s) or which is cited to establish the publication date of another citation or other special reason (as specified) "O" document referring to an oral disclosure, use, exhibition or other means "P" document published prior to the international filing date but later than the priority date claimed	"T" later document published after the international filing date or priority date and not in conflict with the application but cited to understand the principle or theory underlying the invention "X" document of particular relevance; the claimed invention cannot be considered novel or cannot be considered to involve an inventive step "Y" document of particular relevance; the claimed invention cannot be considered to involve an inventive step when the document is combined with one or more other such documents, such combination being obvious to a person skilled in the art. "&" document member of the same patent family
^o Special categories of cited documents : ¹⁰ "A" document defining the general state of the art which is not considered to be of particular relevance "E" earlier document but published on or after the international filing date "L" document which may throw doubts on priority claim(s) or which is cited to establish the publication date of another citation or other special reason (as specified) "O" document referring to an oral disclosure, use, exhibition or other means "P" document published prior to the international filing date but later than the priority date claimed	"T" later document published after the international filing date or priority date and not in conflict with the application but cited to understand the principle or theory underlying the invention "X" document of particular relevance; the claimed invention cannot be considered novel or cannot be considered to involve an inventive step "Y" document of particular relevance; the claimed invention cannot be considered to involve an inventive step when the document is combined with one or more other such documents, such combination being obvious to a person skilled in the art. "&" document member of the same patent family			
IV. CERTIFICATION				
Date of the Actual Completion of the International Search 22 NOVEMBER 1990	Date of Mailing of this International Search Report - 7. 12. 90			
International Searching Authority EUROPEAN PATENT OFFICE	Signature of Authorized Officer DAVID J.Y.H. 			

ANNEX TO THE INTERNATIONAL SEARCH REPORT
ON INTERNATIONAL PATENT APPLICATION NO.

GB 9001256
SA 39674

This annex lists the patent family members relating to the patent documents cited in the above-mentioned international search report.
The members are as contained in the European Patent Office EDP file on
The European Patent Office is in no way liable for these particulars which are merely given for the purpose of information. 22/11/90

Patent document cited in search report	Publication date	Patent family member(s)	Publication date
GB-A-2183883	10-06-87	None	
US-A-2545644		None	
FR-A-463669		None	

EPO FORM P0479

For more details about this annex : see Official Journal of the European Patent Office, No. 12/82