



(22) Date de dépôt/Filing Date: 1996/06/28
 (41) Mise à la disp. pub./Open to Public Insp.: 1996/12/31
 (45) Date de délivrance/Issue Date: 2008/08/05
 (30) Priorité/Priority: 1995/06/30 (JP165886/1995)

(51) Cl.Int./Int.Cl. *C08G 77/388* (2006.01),
A61K 47/34 (2006.01), *A61K 8/89* (2006.01),
A61K 8/895 (2006.01), *A61Q 1/00* (2006.01),
A61Q 19/00 (2006.01), *C08G 77/26* (2006.01),
C08G 77/452 (2006.01), *C08L 83/08* (2006.01),
C08L 83/10 (2006.01)

(72) Inventeurs/Inventors:
 OHNO, HIROYUKI, JP;
 KAWAHARA, NATSUE, JP;
 AMANO, ISABURO, JP;
 SUZUKI, TAKANAO, JP;
 CHIBA, KOJI, JP

(73) Propriétaire/Owner:

(54) Titre : DERIVES DE LA SILICONE; PREPARATION ET UTILISATION
 (54) Title: TRIAZINYL OR PYRIMIDINYL GROUP-CONTAINING AMINO-SILICONES

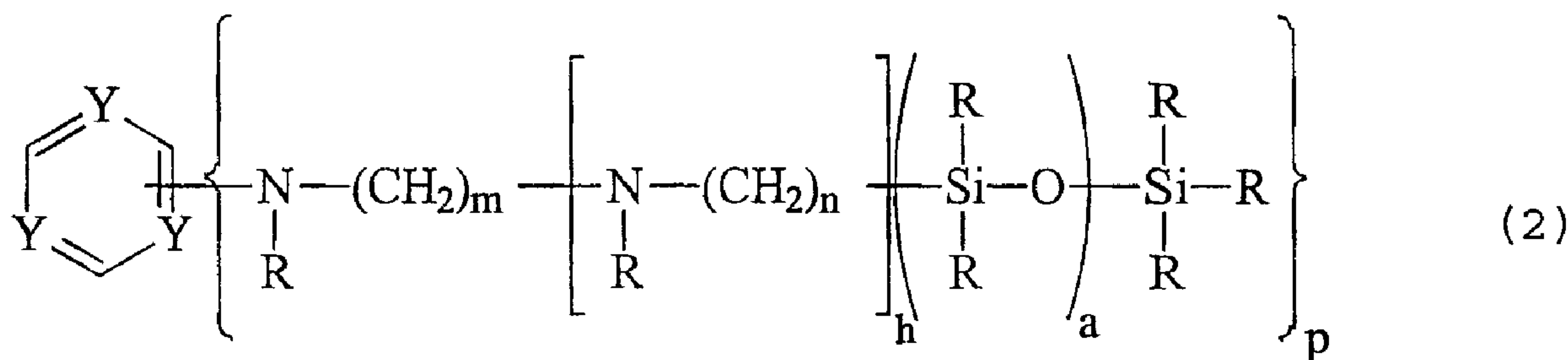

(57) Abrégé/Abstract:

Disclosed are amino silicone derivatives having triazinyl groups or pyrimidinyl groups bound to amino groups of amino silicones, a representative example being given by the formula: (see formula 2) wherein R is H or hydrocarbon; m and n are 1-6; h is 0-6; "a" is 1-400; at least two of Y are N and the other is C; p is 1-3 or 1-4; and the triazinyl or pyrimidinyl group may be substituted. The silicone derivatives are able to gel a silicone oil or to increase the viscosity thereof stably and homogeneously, and therefore are useful as a base for cosmetics, pharmaceutical preparations and industrial materials.

(73) Propriétaires(suite)/Owners(continued):CHIBA FLOUR MILLING CO., LTD., JP

(74) Agent: FETHERSTONHAUGH & CO.

27580-104

TRIAZINYL OR PYRIMIDINYL GROUP-CONTAINING AMINO-SILICONES

ABSTRACT

Disclosed are amino silicone derivatives having triazinyl groups or pyrimidinyl groups bound to amino groups of amino silicones, a representative example being given by the formula:

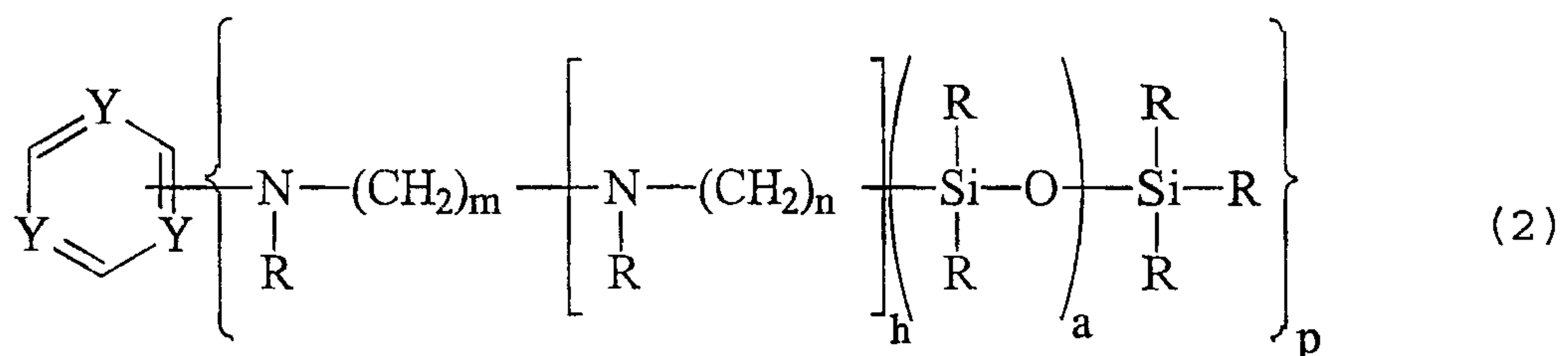

10 wherein R is H or hydrocarbon; m and n are 1-6; h is 0-6;
 "a" is 1-400; at least two of Y are N and the other is C; p
 is 1-3 or 1-4; and the triazinyl or pyrimidinyl group may be
 substituted. The silicone derivatives are able to gel a
 silicone oil or to increase the viscosity thereof stably and
 15 homogeneously, and therefore are useful as a base for
 cosmetics, pharmaceutical preparations and industrial
 materials.

27580-104

- 1 -

TRIAZINYL OR PYRIMIDINYL GROUP-CONTAINING AMINO-SILICONES

FIELD OF THE INVENTION

The present invention relates to novel silicone derivatives, their production and use.

5 BACKGROUND OF THE INVENTION

Silicone oil is useful for its heat resistance, lubricity, water repellency, gloss retention, mist prevention, antistatic properties, mold release lubricant, corrosion resistance, chemical stability and safety.

10 Utilizing these properties, silicone oil has hitherto been used as bases of compositions in a wide variety of fields including various industrial materials such as textile treating agents, surface lubricants, water repelling agents, resin modifiers, paint additives, electrical
15 insulating agents, heat media, grease, oil for machinery, foam stabilizers and anti-foam agents, pharmaceutical preparations and cosmetics.

In particular, silicone oil has been used as bases of pharmaceutical preparations and cosmetics because of its
20 safety. Usually, low-viscosity silicone oil having a viscosity of 100 cs or less at room temperature is widely used as the bases because of its improved extensibility, refreshing feeling and high safety. However, for example, when a paste-like or grease-like silicone composition is
25 prepared, it is difficult to obtain a smooth, homogeneous composition in a single system, and low-viscosity silicone oil is easily separated or discharged from the resulting

composition, resulting in low stability.

In order to solve the above-mentioned problem of low-viscosity silicone oil, there has been proposed the use of organic materials such as the methods of using fatty acid
5 esters of dextrin as thickeners (see Japanese Patent Unexamined Publication Nos. 62-121764, 62-143970, 62-143971 and 63-159489), the methods of using fatty acid esters of sucrose (see Japanese Patent Unexamined Publication No. 63-235366) and the methods of using trimethylsilylated
10 polyvinyl alcohol or trimethylsilylated polysaccharides (see Japanese Patent Unexamined Publication No. 62-240335), and the use of inorganic materials such as the methods of using organically modified viscosity minerals (see Japanese Patent Unexamined Publication Nos. 62-45656, 62-54759 and
15 63-72779). However, the use of these organic and inorganic materials as the thickeners results in the problem of deteriorating inherent characteristics of low-viscosity silicone oil such as refreshing feeling and extensibility.

Recently, methods have been proposed in which low-
20 viscosity silicone oil is treated using compounds obtained by partially crosslinking silicones having a specific degree of polymerization as thickeners under shearing force, thereby obtaining homogeneous paste-like silicone compositions (see Japanese Patent Unexamined Publication
25 Nos. 2-43263 and 5-140320). However, these methods require the use of mixers such as ball mills, three-roll mills and colloid mills having strong shearing force for obtaining

paste-like silicone compositions, resulting in disadvantages such as troublesome preparation, high viscosity of the resulting compositions and restricted compounding amounts of the compositions. Bases have therefore been desired which can make gel and increase viscosity by simpler compounding without impairing the inherent feeling of low molecular weight silicones having a viscosity of 100 cs or less.

SUMMARY OF THE INVENTION

10 As a result of intensive investigation under such situations, the present inventors have discovered that novel silicone derivatives in which triazine compounds or pyrimidine compounds are chemically bound to amino groups of amino-modified silicones can gel silicone oil and/or
15 liquid oil or can increase the viscosity thereof simply and stably, thus completing the present invention.

Namely, the present invention provides:

(1) A triazinyl group- or pyrimidinyl group- containing amino-modified silicone derivative having a
20 triazinyl group or a pyrimidinyl group bound to an amino group of an amino-modified silicone, or a derivative in which triazine or pyrimidine is bound to silicone oil;

(2) A triazinyl group- or pyrimidinyl group- containing amino-modified silicone derivative represented
25 by general formula (1), including a silicone derivative in which a triazinyl group or a pyrimidinyl group is chemically bound to silicone oil as represented by general

represent integers from 1 to 6; h represents an integer from 0 to 6; "a" represents an integer from 1 to 400; at least two of Y are nitrogen atoms, and the remainder is a carbon atom; p represents an integer from 1 to 3 in the case of triazine, or from 1 to 4 in the case of pyrimidine; and when p is 1 or 2 in the case of triazine, or 1, 2 or 3 in the case of pyrimidine, a hydroxyl group, an amino group which may be substituted by a linear or branched alkyl group of 1 to 6 carbon atoms, a halogen atom, a carboxyl group, a linear or branched alkyl group of 1 to 6 carbon atoms, or a linear or branched alkoxy group of 1 to 6 carbon atoms, as well as a hydrogen atom, may be bound to a residual carbon atom of the triazine ring or the pyrimidine ring;

(4) The silicone derivative described in the above (1), which is represented by general formula (3):

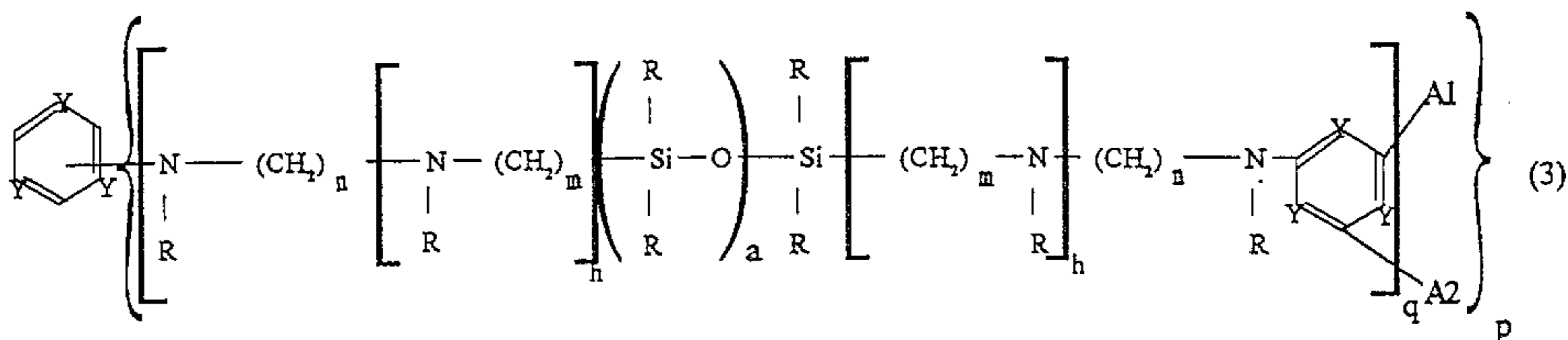

wherein each R, which may be the same or different, represents hydrogen or a linear, branched-chain or cyclic hydrocarbon group of 1 to 8 carbon atoms; m and n each represent integers from 1 to 6; h represents an integer from 0 to 6; "a" represents an integer from 1 to 400; at least two of Y are nitrogen atoms, and the remainder is a

carbon atom; q is an integer from 0 to 10; p represents an integer from 1 to 3 in the case of triazine, or from 1 to 4 in the case of pyrimidine; and when p is 1 or 2 in the case of triazine, or 1, 2 or 3 in the case of pyrimidine, a hydroxyl group, an amino group which may be substituted by a linear or branched alkyl group of 1 to 6 carbon atoms, a halogen atom, a carboxyl group, a linear or branched alkyl group of 1 to 6 carbon atoms, or a linear or branched alkoxy group of 1 to 6 carbon atoms, as well as a hydrogen atom, may be bound to a residual carbon atom of the triazine ring or the pyrimidine ring;

(i) When q is from 1 to 10, A1 and A2 are each represented by general formula (4):

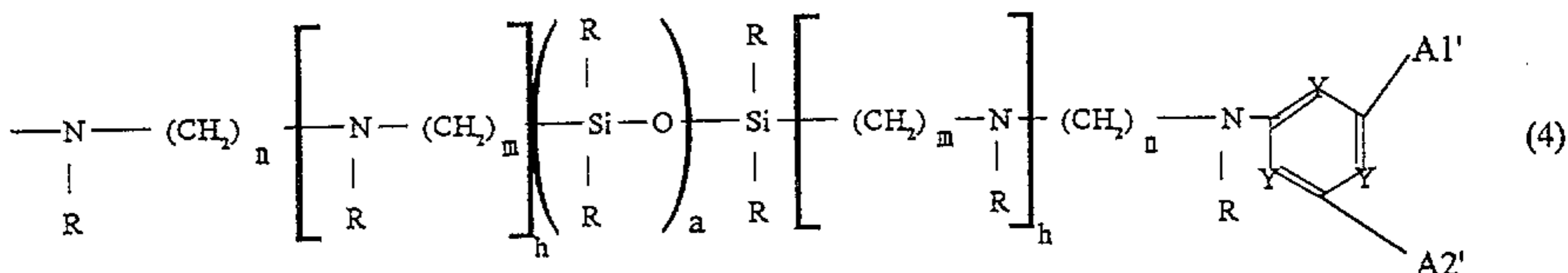

wherein R, m, n, h, a and Y have the same meanings as given above; and A1' and A2' each represent hydrogen atoms, hydroxyl groups, amino groups which may be substituted by linear or branched alkyl groups each having 1 to 6 carbon atoms, halogen atoms, carboxyl groups, linear or branched alkyl groups each having 1 to 6 carbon atoms, or linear or branched alkoxy groups each having 1 to 6 carbon atoms; or A1 and A2 are each represented by general formula (5):

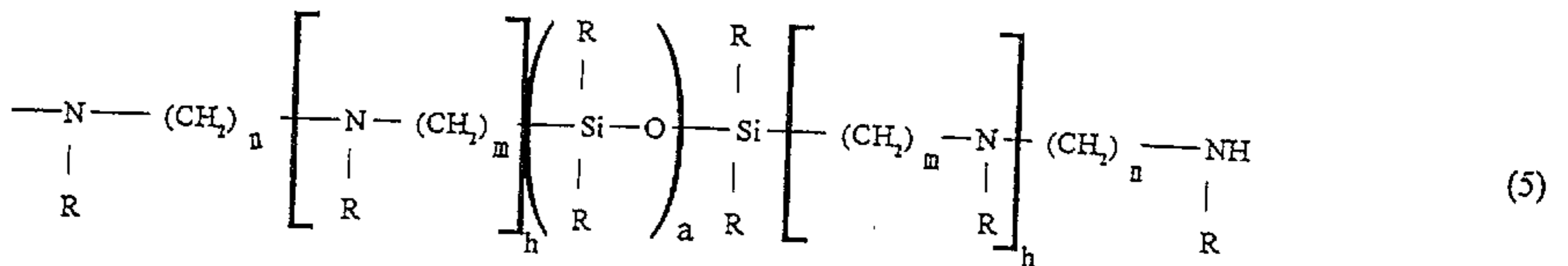

5

wherein R, m, n, h and a have the same meanings as given above;

or A1 and A2 each represent hydrogen atoms, hydroxyl groups, amino groups which may be substituted by linear or
 10 branched alkyl groups each having 1 to 6 carbon atoms, halogen atoms, carboxyl groups, linear or branched alkyl groups each having 1 to 6 carbon atoms, or linear or branched alkoxy groups each having 1 to 6 carbon atoms;
 and

15 (ii) When q is 0, general formula (3) is represented by general formula (6):

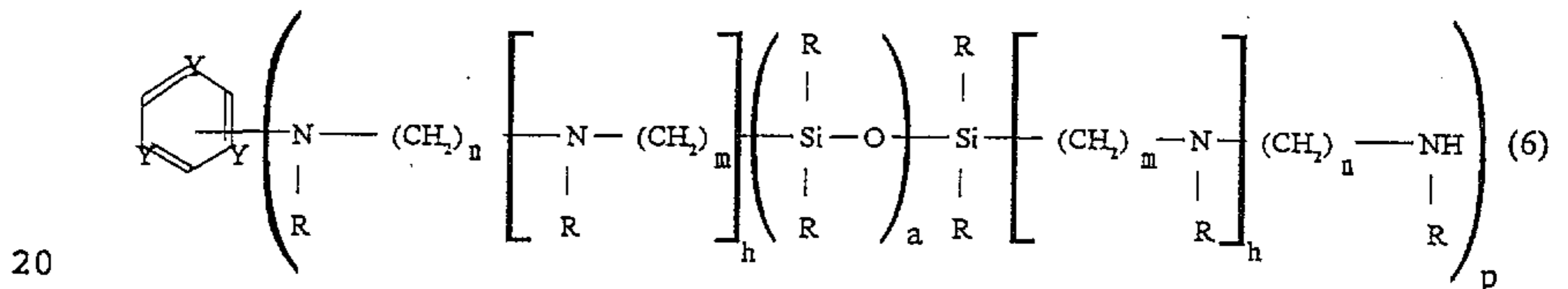

20

said silicone derivative including a derivative in which 1 to 3 carbon atoms of the triazine ring or 1 to 4 carbon atoms of the pyrimidine ring are bound to α,ω -diamino silicone oil at both amino ends thereof, also including a
 25 structure composed of 2 to 10 repeating units thereof which includes a linear, branched and/or network structure, and including a derivative in which one end of the α,ω -diamino

silicone oil may be an amino group or an amino group substituted by a linear or branched alkyl group of 1 to 6 carbon atoms without bonding to the triazinyl group or the pyrimidinyl group;

- 5 (5) The silicone derivative described in the above (1) represented by general formula (7), which is obtained by allowing a side-chain amino silicone oil to react with a reactive group-containing triazine or pyrimidine compound:

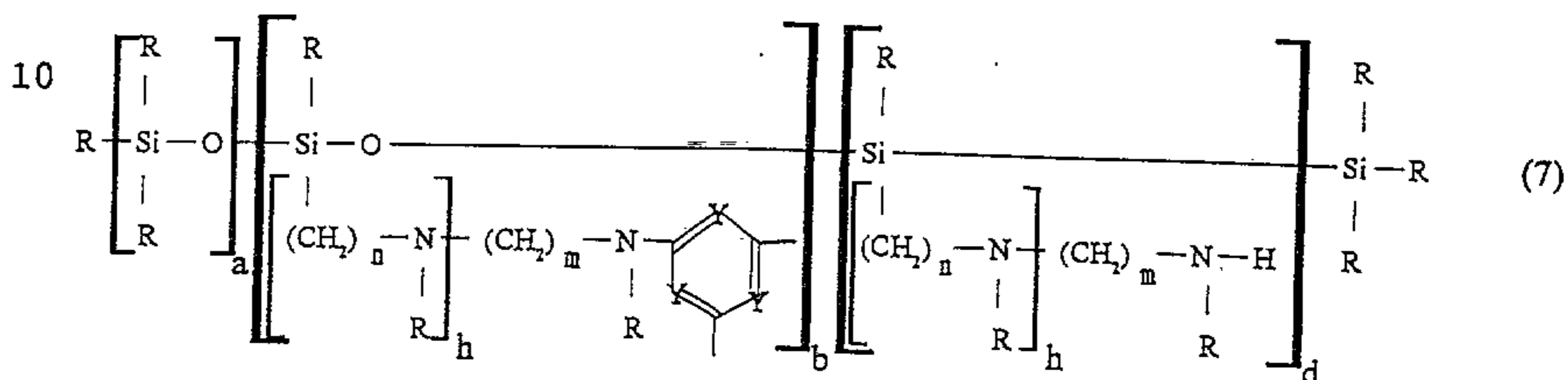

15 wherein each R, which may be the same or different, represents hydrogen or a linear, branched-chain or cyclic hydrocarbon group of 1 to 8 carbon atoms; m and n each represent integers from 1 to 6; h represents an integer

20 from 0 to 6; "a" and "b" each represent integers of 1 or more, "d" represents an integer of 0 or more, and "a+b+d" represents an integer of 400 or less; "a", "b" and "d" each show the ratios, and do not specify the order of

25 arrangement; and at least two of Y are nitrogen atoms, and the remainder is a carbon atom;

- (6) A method for producing the silicone derivative described in the above (1) which comprises allowing a amino

silicone oil to react with a reactive group-containing triazine or pyrimidine compound;

(7) The method described in the above (6), in which the amino silicone oil is represented by the following
5 general formula (8):

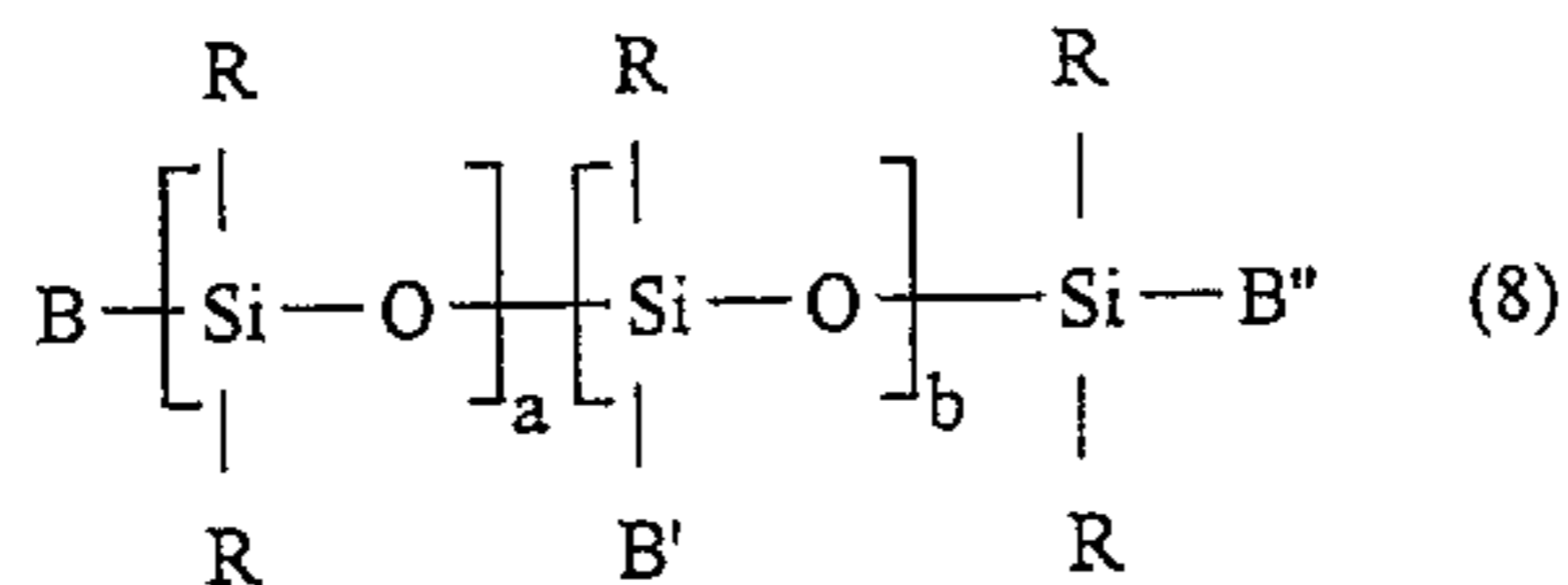

10

wherein each R, which may be the same or different, represents hydrogen or a linear, branched-chain or cyclic hydrocarbon group of 1 to 8 carbon atoms; a and b each represent integers of 1 or more, and the sum of a and b
15 represents an integer of 400 or less; a and b each show the ratios, and do not specify the order of arrangement; and at least one of B, B' and B'' is a group represented by general formula (9):

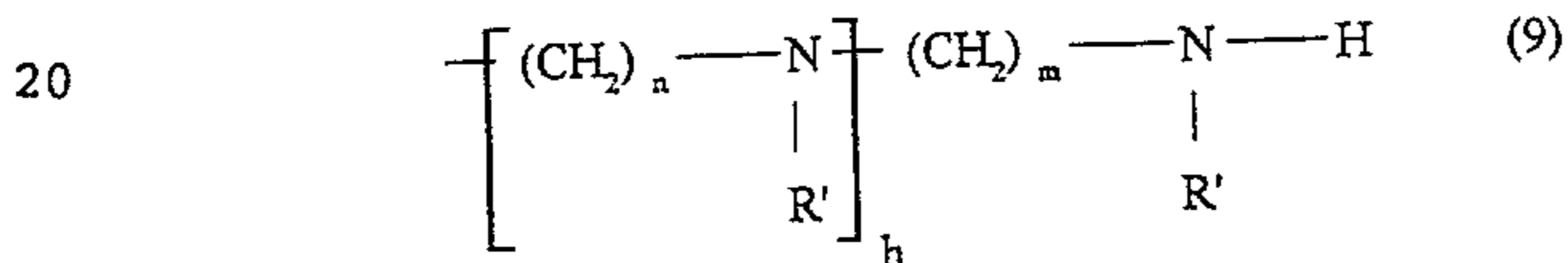

20

wherein each R', which may be the same or different, represents hydrogen or a linear, branched or cyclic
25 hydrocarbon group of 1 to 8 carbon atoms; m and n each represent integers from 1 to 6; and h represents an integer from 0 to 6; and

the reactive group-containing triazine or pyrimidine compound is a compound represented by the following general formula (10):

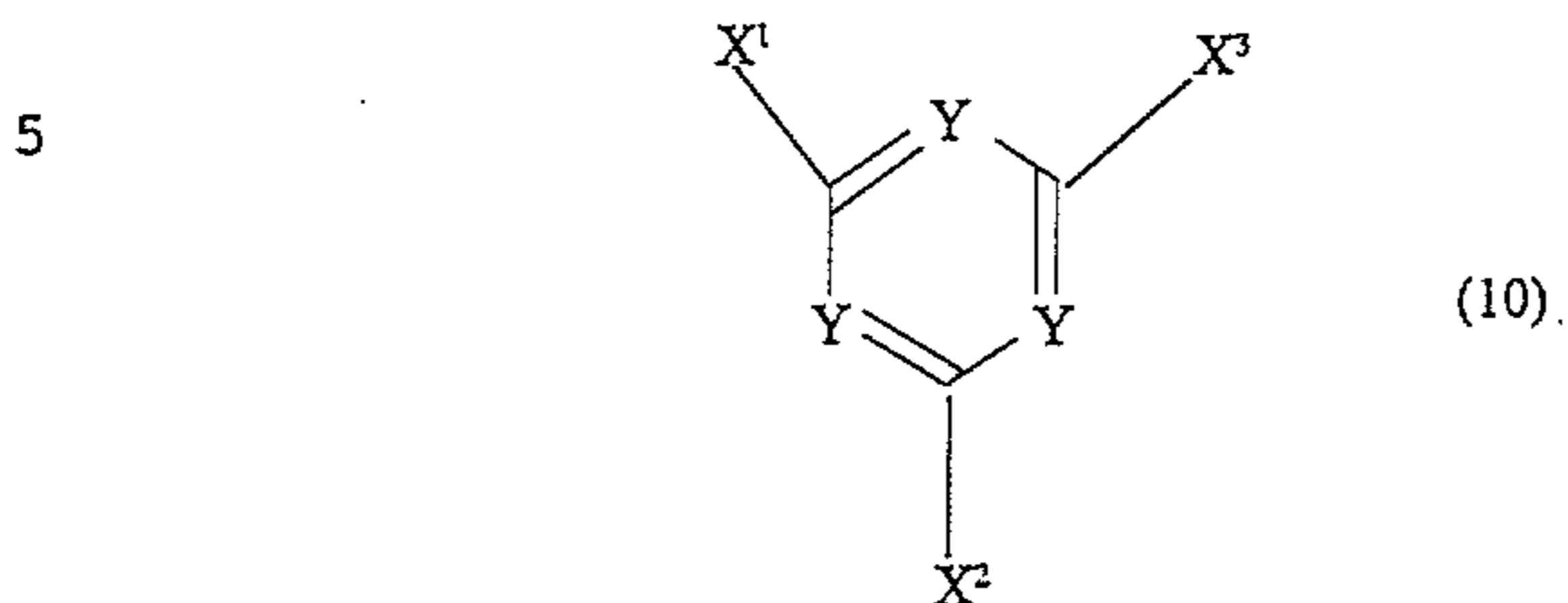

10 wherein at least one of X¹, X² and X³ represents a halogen atom, the remainders each represent hydrogen atoms, hydroxyl groups, amino groups which may be substituted by linear or branched alkyl groups each having 1 to 6 carbon atoms, carboxyl groups, linear or branched alkyl groups
 15 each having 1 to 6 carbon atoms, or linear or branched alkoxy groups each having 1 to 6 carbon atoms; and at least two of Y are nitrogen atoms, and the other is a carbon atom;

(8) A gelling agent comprising the triazinyl group-
 20 or pyrimidinyl group-containing silicone derivative described in the above (1), (2), (3), (4) or (5);

(9) A composition comprising the triazinyl group- or pyrimidinyl group-containing silicone derivative described in the above (1), (2), (3), (4) or (5) and silicone oil
 25 and/or liquid oil; and

(10) A base comprising the triazinyl group- or pyrimidinyl group-containing silicone derivative described

in the above (1), (2), (3), (4) or (5).

DESCRIPTION OF THE PREFERRED EMBODIMENTS

The present invention will hereinafter be described in detail.

5 When the novel silicone derivatives of the present invention are produced, in addition to methods in which amino silicone oil is allowed to react with reactive group-containing triazine or pyrimidine compounds as raw materials, methods can be employed in which reactive group-
10 modified silicones having reactive groups such as halogen and amino group-containing triazine or pyrimidine compounds are allowed to react with each other, which has a reversed relationship in the reactive groups with the first method. This is the reason why the silicone derivatives of the
15 present invention include all compounds represented by general formula (1). However, the reactivity of the reactive groups such as halogen on heterocyclic moiety is stronger in the first method, so that the first method is generally used. The first method is hereinafter mainly
20 described, but the second method can also be used similarly.

As the starting materials for producing the novel silicone derivatives of the present invention, the case of using amino silicones is first described. The sites of
25 amino modification may be any of side chains, one end and both ends, and the number of the amino groups, the position thereof, etc. are not limited.

These amino silicones are represented by the following general formula (11):

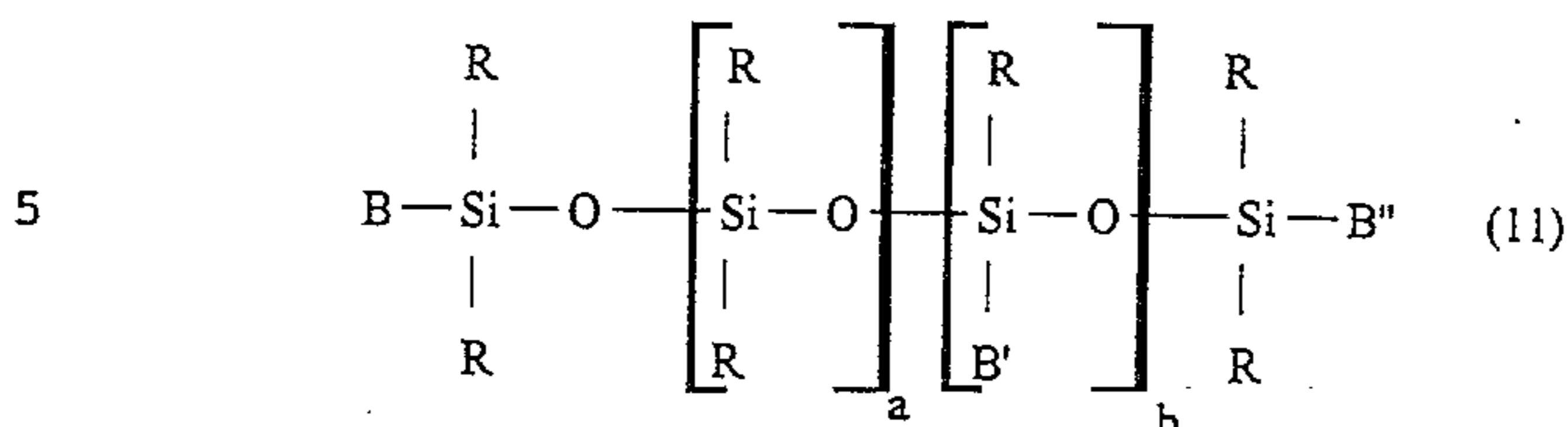

wherein each R, which may be the same or different, represents a linear, branched-chain or cyclic hydrocarbon group of 1 to 8 carbon atoms; at least one of B, B' and B'' is a group represented by general formula (12):

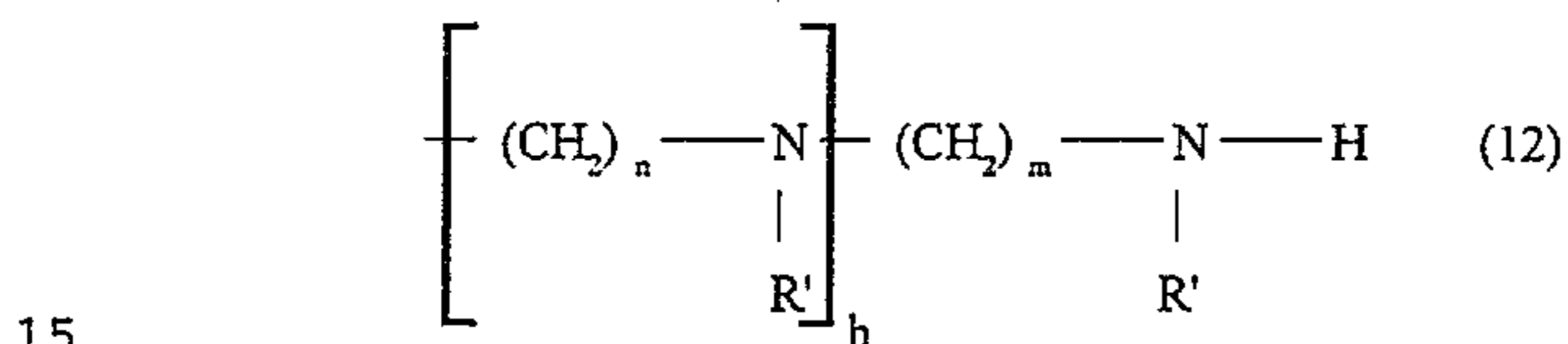

wherein each R', which may be the same or different, represents hydrogen or a linear, branched or cyclic hydrocarbon group of 1 to 8 carbon atoms, m and n each represent integers from 1 to 6, and h represents an integer from 0 to 6; the remainders of B, B' and B'' each represent linear, branched-chain or cyclic hydrocarbon groups each having 1 to 8 carbon atoms; a and b each represent integers of 1 or more, and the sum of a and b represents an integer of 400 or less; and a and b each show the ratios, and do not specify the order of arrangement.

Examples thereof include amino silicones having one amino end group represented by the following general

formula (13):

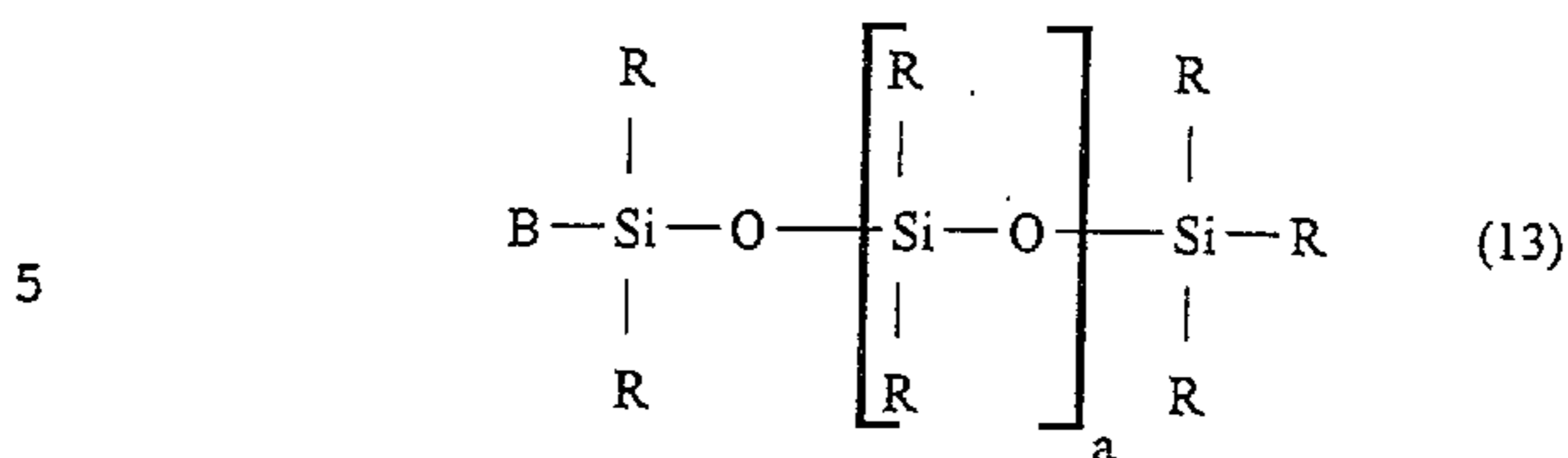

wherein each R, which may be the same or different,
 represents hydrogen or a linear, branched-chain or cyclic
 10 hydrocarbon group of 1 to 8 carbon atoms; B represents a
 group represented by general formula (12); and a represents
 an integer from 1 to 400;

α,ω -diamino silicones represented by the following general
 formula (14):

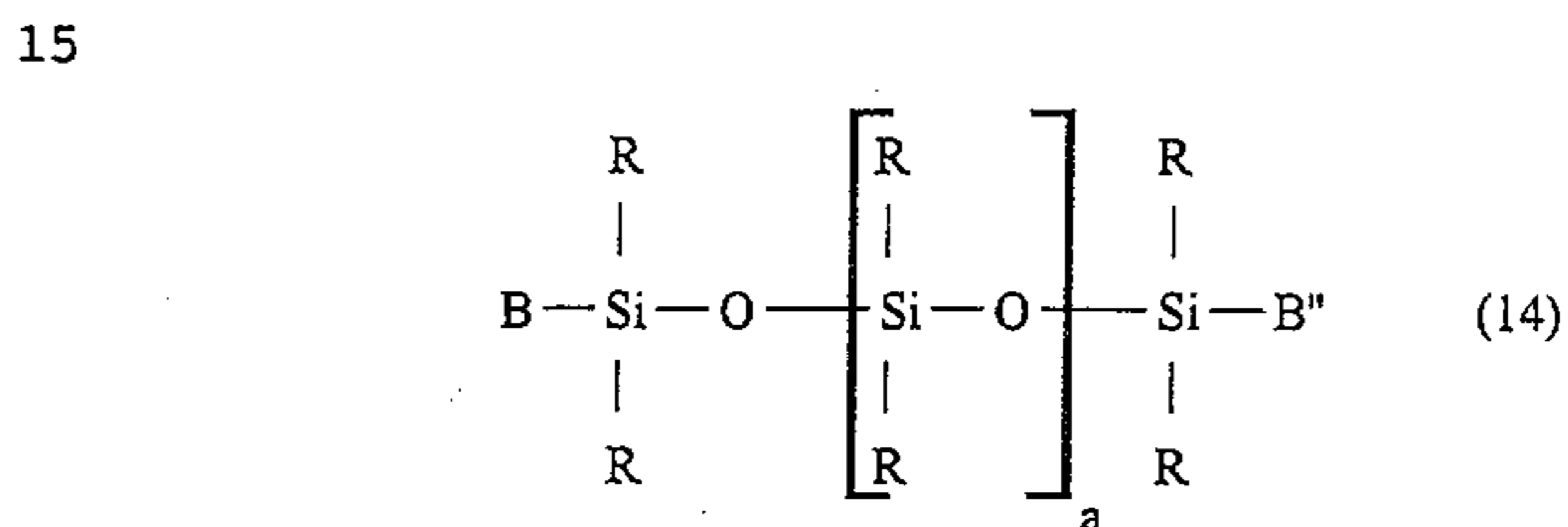

20
 wherein each R, which may be the same or different,
 represents hydrogen or a linear, branched-chain or cyclic
 hydrocarbon group of 1 to 8 carbon atoms; B and B'' each
 represent groups represented by general formula (12); and a
 25 represents an integer from 1 to 400; and
 side-chain amino silicones represented by the following
 general formula (15):

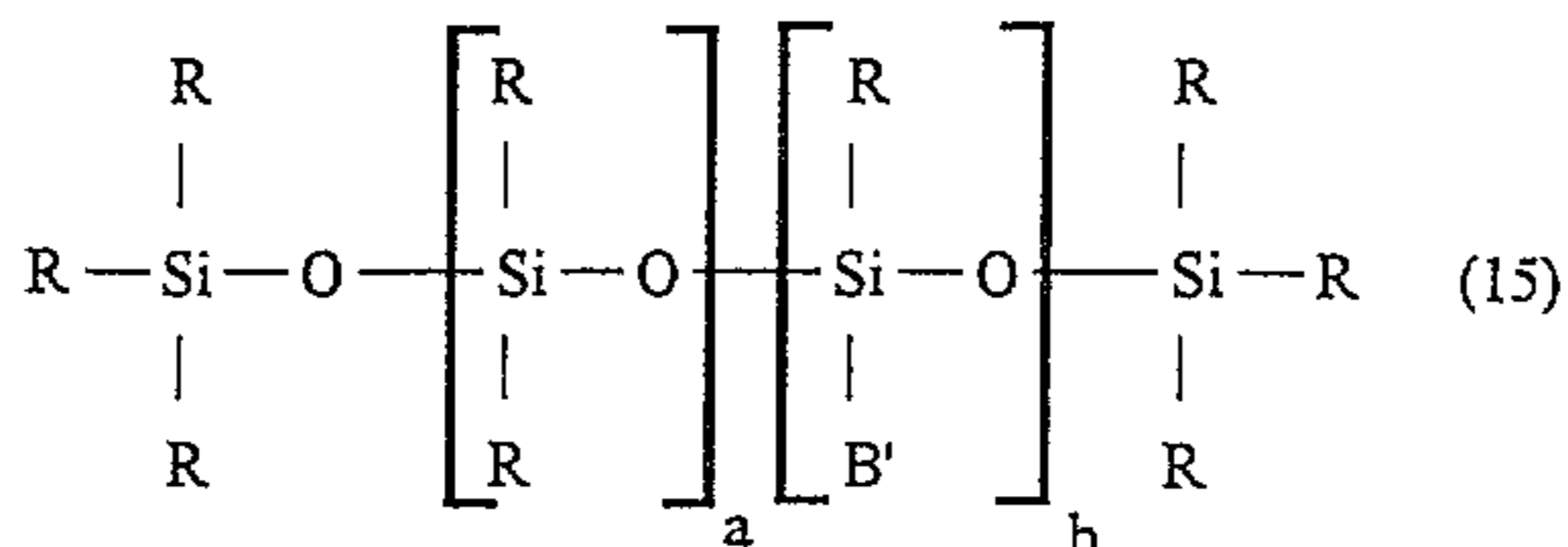

5 wherein each R, which may be the same or different,
 represents hydrogen or a linear, branched-chain or cyclic
 hydrocarbon group of 1 to 8 carbon atoms; B' represents a
 group represented by general formula (12); a and b each
 represent integers of 1 or more, and the sum of a and b
 10 represents an integer of 400 or less; and a and b each show
 the ratios, and do not specify the order of arrangement.

In the compounds represented by general formulas (13),
 (14) and (15), the amino silicone derivatives used in the
 present invention, examples of the hydrocarbon groups each
 15 having 1 to 8 carbon atoms represented by R include linear
 hydrocarbon groups such as methyl, ethyl, propyl, butyl,
 pentyl, hexyl, heptyl and octyl, branched hydrocarbon
 groups such as isopropyl and isohexyl, alkenyl groups such
 as vinyl and allyl, cycloalkyl groups such as cyclohexyl
 20 and cycloheptyl, and aryl groups such as phenyl and tolyl.
 These hydrocarbon groups may be substituted by halogen,
 etc., and examples thereof include 3,3,3-trifluoropropyl.
 Methyl and phenyl are preferred among others, and methyl is
 particularly preferred.

25 In the compounds represented by general formulas (13),
 (14) and (15), the number of silicon atoms contained in a
 modified silicone molecule (a+b) is 2 to 400, preferably 10

to 300, and more preferably 40 to 150. Those compounds preferably have an amino equivalent of about 100 to 10,000, more preferably about 500 to 5,000.

Examples of the amino silicones used in the present invention include the following:

- 5 Amino Silicone Oil Manufactured by Dow Corning Toray Silicone Co., Ltd.

Structure (1) (α,ω -diamino silicone)

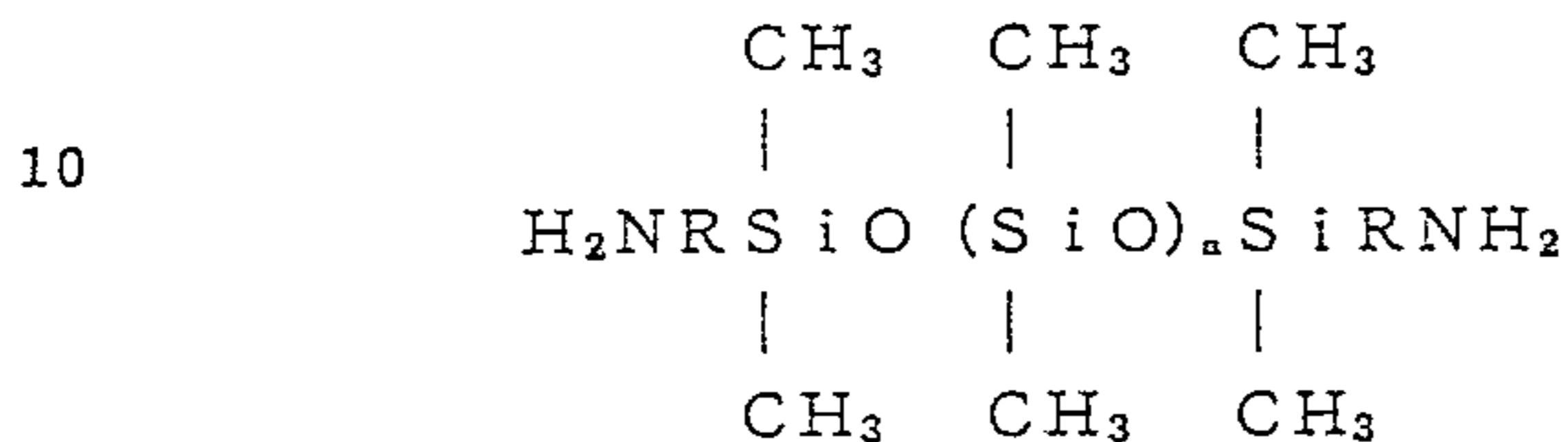

Structure (2) (Side-Chain amino silicone)

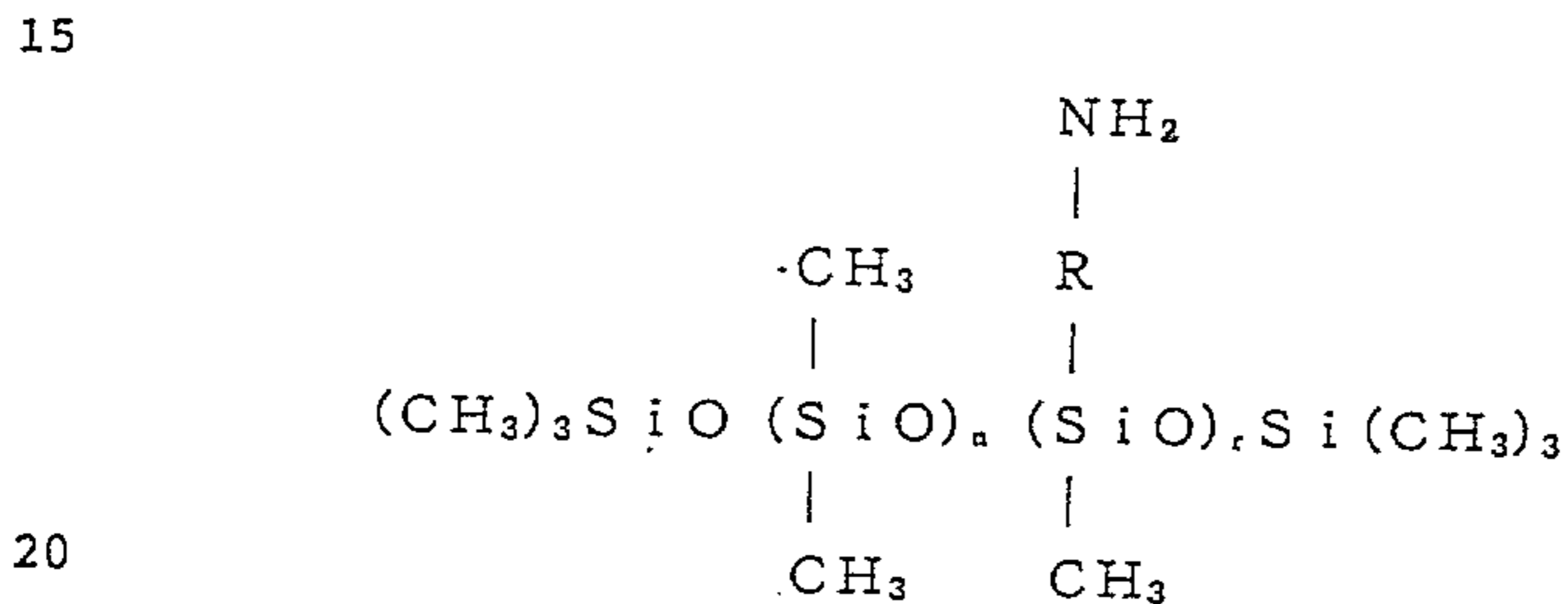

R: Alkylene

	<u>Product Name</u>	<u>Viscosity (cs)</u>	<u>Specific Gravity</u>	<u>Refractive Index</u>	<u>Remarks</u>	<u>NH₂ equivalent</u>
5	BY16-853	30	0.96	1.414	α,ω -diamino silicone	650
	BY16-853B	80	0.97	1.407	ditto	2200
10	BY16-828	120	1.05	1.453	side-chain amino silicone	3500
	BY16-850	1100	0.98	1.411	ditto	4000
15	SF8417	1200	1.07	1.452	ditto	1800
	BY16-849	1300	1.03	1.426	ditto	600
	BY16-872	18000	1.01	1.421	ditto	2000
20	BX16-755B	240	-	1.408	secondary amine	2200
	BX16-193	-	-	-	one amino end group	4000

25

Amino Silicone Oil Manufactured by Nippon Unicar Co., Ltd.

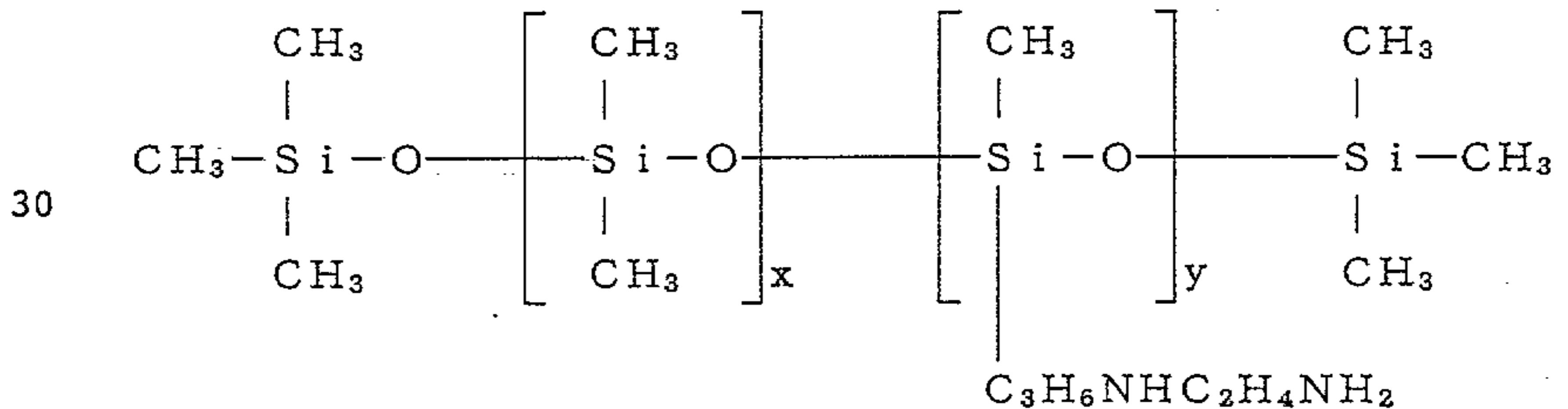

	<u>Product Name</u>	<u>Amino Equivalent</u>	<u>Si Polymerization Degree</u>
35	FZ-3705	4,000	140
	FZ-3707	1,400	50
	FZ-3710	1,700	300
	FZ-3712	1,700	200

Amino Silicone Oil Manufactured by Dow Corning Toray Silicone Co., Ltd.

<u>Product Name</u>	<u>Appearance</u>	<u>Viscosity (cs)</u>	<u>Specific Gravity</u>	<u>Refractive Index</u>	<u>Amino Equivalent</u>
SF8417	light yellowish brown, transparent	1200	0.96	1.407	1800
BY16-828	light yellow, transparent	120	0.96	1.408	3500
BY16-849	ditto	1300	0.99	1.414	600
BY16-850	ditto	1100	0.97	1.405	4000
BY16-872	ditto	18000	0.98	1.407	2000
BY16-853	light yellow, transparent	30	0.96	1.414	650
BY16-853B	colorless, transparent	80	0.97	1.407	2200
BX16-755B		240	-	1.408	

R, R': Alkylene

The molecular weight of these amino silicones is 100 to 30,000, preferably 1,000 to 20,000, and more preferably 3,000 to 10,000.

The triazine and pyrimidine compounds having reactive functional groups which are used for reaction with the amino silicones are represented by the following general formula (10):

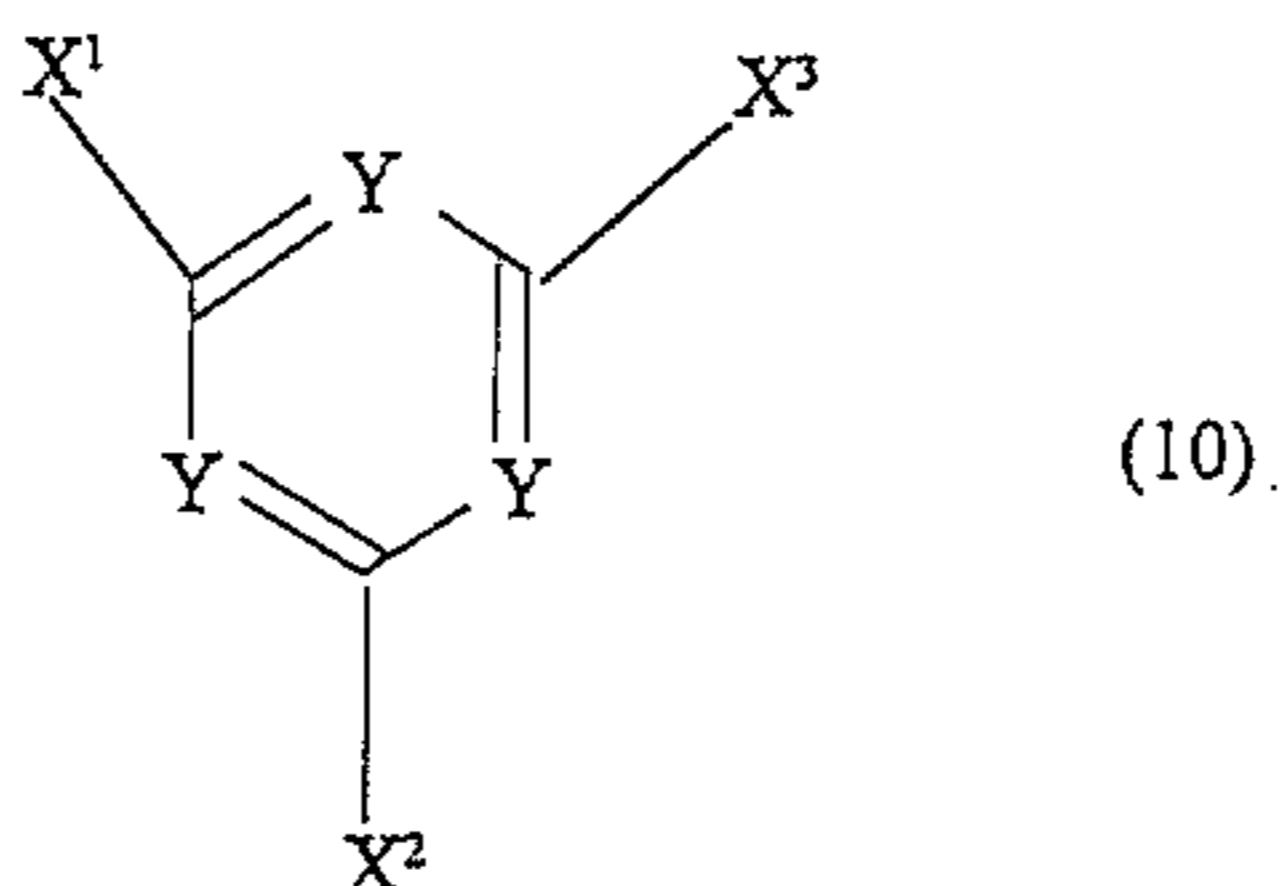

wherein at least one of X^1 , X^2 and X^3 represents a halogen atom, the remainders each represent hydrogen atoms, hydroxyl groups, amino groups which may be substituted by linear or branched-chain alkyl groups each having 1 to 6 carbon atoms, carboxyl groups, linear or branched alkyl groups each having 1 to 6 carbon atoms, or linear or branched alkoxy groups each having 1 to 6 carbon atoms; and at least two of Y are nitrogen, and the other is carbon.

The reactive groups of these triazine or pyrimidine compounds may be any, as long as they are groups which react with amino groups of the amino silicones. Examples thereof include halogen atoms such as fluorine, chlorine, bromine and iodine. Although substituent groups X^1 and X^2

of the triazine skeleton may also be any, examples thereof include hydrogen, hydroxyl, amino groups which may be substituted by alkyl groups, halogen, carboxyl, linear or branched alkyl groups each having 1 to 6 carbon atoms, or linear or branched alkoxy groups each having 1 to 6 carbon atoms. In the amino groups which may be substituted by the alkyl groups, said alkyl groups include linear or branched alkyl groups each having 1 to 6 carbon atoms. Examples of the alkyl-substituted amino groups include ethylamino, propylamino and isopropylamino. Further, the carboxyl groups contain salts thereof such as alkali salts and alkaline earth metal salts, and examples thereof include sodium, potassium, calcium, magnesium, aluminum and zinc salts. Examples of the linear or branched alkyl groups each having 1 to 6 carbon atoms include linear alkyl groups such as methyl, ethyl, propyl, butyl, pentyl and heptyl, branched alkyl groups such as isopropyl, isobutyl, isopentyl and isohexyl, and those of cyclic alkyl groups such as cyclohexyl. Examples of the linear or branched alkoxy groups each having 1 to 6 carbon atoms include methoxy, ethoxy, propoxy, butoxy, pentaoxy, isopropoxy and dimethoxy.

Examples of these triazine compounds include cyanuric chloride, 2-chloro-4,6-bis(methylamino)-S-triazine, 2-chloro-4,6-bis(ethylamino)-S-triazine (simazine), 2-chloro-4,6-bis(propylamino)-S-triazine, 2-chloro-4,6-bis(butylamino)-S-triazine, 2-chloro-4,6-bis(amylamino)-S-triazine,

2-chloro-4-methylamino-6-ethylamino-S-triazine, 2-chloro-4-methylamino-6-propylamino-S-triazine, 2-chloro-4-ethylamino-6-isopropylamino-S-triazine (atrazine), 2-chloro-4-ethylamino-6-propylamino-S-triazine, 2-chloro-4-ethylamino-6-isobutylamino-S-triazine, 2-chloro-4-propylamino-6-isopropylamino-S-triazine, 2-chloro-4,6-bis(ethoxy)-S-triazine, 2-chloro-4,6-bis(methoxy)-S-triazine, 2-chloro-4,6-bis(propoxy)-S-triazine and 2-chloro-4,6-bis(butoxy)-S-triazine.

Examples of the pyrimidine compounds include 2-chloropyrimidine, 2-chloro-4,6-dimethylpyrimidine, 2-chloro-4,6-(dimethylamino)pyrimidine, 2,5-dichloro-4-methoxy-6-trichloromethylpyrimidine and 2,4,5,6-tetrachloropyrimidine.

On the other hand, in addition to the methods in which the above-mentioned amino silicones are allowed to react with the reactive group-containing triazine or pyrimidine compounds as starting materials, the novel silicone derivatives of the present invention can also be produced by allowing reactive group-containing silicones to react with amino group-containing triazine or pyrimidine compounds. When the reactive group-containing silicones are used, halogen is typically used as the reactive groups. The halogen silicones include, for example, chloro silicone oil and fluoro silicone oil. Examples of the amino group-containing triazine compounds which are allowed to react with the halogen silicone oil include 2,4,6-triamino-s-

triazine (melamine), 2,4-diamino-6-dimethyl-s-triazine and 2,4-diamino-6-ethoxy-s-triazine. Examples of the amino group-containing pyrimidine compounds include 2-aminopyrimidine, 2,4-diamino-6-ethyl-5-phenylpyrimidine, 2-amino-4-(2-dibutylaminoethoxy)pyrimidine, 5-(4'-chlorophenyl)-2,4-diamino-6-ethylpyrimidine and 2,4,5,6-tetraaminopyrimidine.

10

Reaction solvents used in the reaction of these amino silicones with the triazine or pyrimidine compounds or in the reaction of the halogen silicone oil with the amino group-containing triazine or pyrimidine compounds may be any, as long as they dissolve both of them. Such solvents include benzene, toluene, xylene, n-hexane, n-heptane, carbon tetrachloride, chloroform, perchloroethylene, trichloroethylene and chlorobenzene.

The reaction is conducted by dissolving the amino silicone oil or the halogen silicone oil and the triazine compounds or the pyrimidine compounds in the reaction solvents, and heating and adding catalysts if necessary.

20

The reaction is conducted at room temperature or higher, preferably at 70 to 120°C, and basic compounds such as pyridine, aniline and alkylamines can be used as the reaction catalysts. After the reaction, unreacted halogen groups may be substituted by water, alcohols, etc., followed by solvent removal and removal of unreacted products. Then, the resulting products may be subjected to vacuum drying

to obtain the novel silicone derivatives in which triazinyl groups or pyrimidinyl groups are bound to the amino silicone oil or the halogen silicone oil.

The properties such as gel strength and viscosity can be controlled by changing the binding ratio of the amino silicone to the triazinyl group or the pyrimidinyl group.

For example, when added to liquid oil or silicone oil generally used for cosmetics or pharmaceutical preparations, a di-substituted compound in which silicone oil is introduced into two positions of the triazinyl group or the pyrimidinyl group forms a hard gel, a mono-substituted compound in which silicone oil is introduced into one position forms a soft gel, and a tri-substituted compound in which silicone oil is introduced into all three positions gives a weak gel or a viscosity-increased fluid liquid. With respect to cosmetics, for example, the di-substituted compounds are used for foundations, antiperspirants sticks, mascara, lip sticks and lip cream, the mono-substituted compounds are used for soft gels such as cream, emulsions and cream foundations, and the tri-substituted compounds are used for cosmetic oil and liquid foundations. Further, the di-substituted compounds forming hard gels are used for potting agents for electric and electronic parts and vibration absorbing agents for dampers, and the tri-substituted compounds are used for thickeners, sealing agents and pigment dispersing agents. Thus, any one of the mono-substituted, di-substituted and

tri-substituted compounds can be selected depending on the use and the purpose.

Reaction products in which halogen is left cause irritating feeling when they adhere to the skin. They are therefore unsuitable for cosmetics and pharmaceutical preparations. It is therefore preferred that halogen is substituted as described above. However, the reaction products containing halogen can be used for other applications such as water repelling agents, potting agents for electric and electronic parts and vibration absorbing agents for dampers, etc. without any particular problem.

When the amino silicone is an α,ω -diamino silicone or a side chain amino silicone, a compound in which triazinyl or pyrimidinyl groups are bound to all amino groups of the α,ω -diamino silicone or the side chain amino silicone is not dissolved in liquid oil or silicone oil even when it is added thereto, or the resulting gel leads to syneresis in some cases. The reason for this is considered to be that the hard gel is formed by intramolecular or intermolecular crosslinking. A reversible smooth gel can be formed by partially leaving the amino groups unreacted by methods such as appropriate adjustment of the reaction molar ratio, which is deduced to be due to a hydrogen bond.

For example, when the side chain amino silicone has amino groups at 40 positions in a molecule, a gelling agent can be obtained by introducing triazinyl or pyrimidinyl groups into 2 or 3 positions, such gelling agent gives a

homogeneous, flexible, soft gel when added to silicone oil having a viscosity of 100 cs or less.

The compounds of the present invention represented by general formula (3) which are obtained by the reaction of the α,ω -diamino silicones with reactive triazine or pyrimidine can be compounds showing fluidity, compounds showing viscosity increasing properties, gel-like compounds or rubber-like elastomers, depending on the reaction conditions such as the reaction molar ratio, the reaction temperature and the reaction time.

For example, when a soft gel is desired, the reaction time is shortened, or the amount of the reactive group-containing triazine or pyrimidine compound is reduced in the reaction. When a harder gel is desired, the reaction time is prolonged, or the amount of the reactive group-containing triazine or pyrimidine compound is increased. Thus, the hardness of product gels can be controlled.

These compounds vary in viscosity according to the degree of polymerization (molecular weight) represented by q in general formula (3), and a higher molecular weight results in a higher viscosity. In addition to this, the linear structure and the crosslinked structure are obtained as the molecular structure according to methods of polymerization. The linear structure results in softer compounds compared with the crosslinked structure. For example, gel-like compounds rich in the linear structure are soft, whereas gels rich in the crosslinked structure

become hard, resulting in elastic, rubber-like compounds.

Specifically, the products are described as follows.

When the products are mainly composed of the compounds represented by general formula (3) wherein q is 3 or less, the products are poor in the crosslinked structure and rich in the linear structure. Dissolution thereof in silicone oil results in various compounds extending from high viscous materials exhibiting viscosity increasing properties to weak gel-like compounds.

When the products are mainly composed of the compounds represented by general formula (3) wherein q is 5 to 10, the crosslinked structure is rich, resulting in exhibition of properties extending from weak gel-like properties to hard rubber-like properties.

When the products are mainly composed of the compounds represented by general formula (3) wherein q exceeds 10, the products are almost all composed of the crosslinked structure and further composed of the polymer structure, resulting in exhibition of properties extending from rubber-like properties to resin-like properties.

Similarly to the α,ω -diamino silicones, the compounds of the present invention represented by general formula (7) which are obtained by the reaction of the side-chain amino silicones with reactive triazine or pyrimidine compounds vary in viscosity according to the degree of polymerization (molecular weight) represented by $(a+b+d)$, and a higher molecular weight results in a higher viscosity. For the

linear structure and the crosslinked structure developed as the molecular structure according to methods of polymerization, the linear structure results in softer compounds compared with the crosslinked structure. For example, gel-like compounds rich in the linear structure are flexible and soft, whereas gels rich in the crosslinked structure become hard, resulting in elastic, rubber-like compounds.

When cyanuric chloride is used as the triazine compound, it can bind to reactive groups of the silicone at a maximum of 3 positions, because it has 3 reactive groups. The structure of the silicone obtained thereby is apt to take the crosslinked structure, compared with a compound having one reactive group such as 2-chloropyrimidine. The resulting compound has therefore a tendency to become hard.

Further, more amino groups in the molecule of the amino silicone results in more reactive positions, so that the resulting compound is apt to take the crosslinked structure, leading to a hard compound. Accordingly, the use of the silicone having a small amount of amino groups can provide the silicone derivative having desired hardness and properties.

As an example of the specific structure, the side-chain amino silicone is apt to take the intermolecular or intramolecular crosslinked structure when the triazine or pyrimidine compound having at least 2 reactive groups is used, resulting in a hard compound. In order to avoid this

problem, the introduction rate of the triazine or pyrimidine compound is decreased, or the triazine compound having one reactive group such as 2-chloro-4,6-bis(ethylamino)-s-triazine or the pyrimidine compound such as 2-chloropyrimidine is used, whereby a compound having moderate gel properties can be obtained.

More amino groups in the side-chain amino silicone oil results in a harder gel. It is therefore preferred that the number of amino groups is proper. In order to obtain the soft gel-like product, the number of amino groups in the molecule is preferably 5 or less.

As described above, the hard gels, the soft gels and the liquid triazinyl group- or pyrimidinyl group-containing amino silicone derivatives are obtained according to various conditions, and they can be selected depending on each application, similarly to the above-mentioned various substituted compounds.

The novel triazinyl group- or pyrimidinyl group-containing amino silicone derivatives of the present invention are dispersed in liquid oil or silicone oil, and dissolved by heating, followed by cooling if necessary, thereby obtaining compositions extending from gel-like compositions to viscous materials.

The amount of the triazinyl group- or pyrimidinyl group-containing amino silicone derivative of the present invention added to the silicone oil varies with the molecular weight, etc. of the triazinyl group- or

pyrimidinyl group-containing amino silicone derivative, and a higher molecular weight and a higher viscosity of the silicone derivative require a smaller amount thereof added. On the other hand, a lower molecular weight and a lower viscosity of the silicone derivative require a larger amount thereof added. In the latter case, the triazinyl group- or pyrimidinyl group-containing amino silicone derivative itself can also be used as a base. When used as a gelling agent, the triazinyl group- or pyrimidinyl group-containing amino silicone derivative of the present invention is added generally in an amount of 3% by weight or more, and preferably in an amount of 10% by weight or more. The gelling agent of the present invention also includes so-called viscosity thickening agents which increase the viscosity of the bases but leave the fluidity, as well as the so-called gelling which increases the viscosity and allows the fluidity to disappear.

The liquid oil may be any as long as it is compatible with the silicone derivatives of the present invention, and examples thereof include hydrocarbon oil such as isoparaffin oil, and ester oil. The silicone oil may be any as long as it is liquid, and chain silicones, cyclic silicones, amino-, carboxyl- or alcohol- silicones, etc. can be used.

The triazinyl group- or pyrimidinyl group-containing amino silicone derivatives of the present invention are dissolved in low-viscosity silicone oil, hydrocarbon oil,

polar oil, etc. to cause gelation or an increase in viscosity. They can be therefore used as bases for various industrial materials as well as for cosmetics and pharmaceutical preparations. In addition, the triazinyl group- or pyrimidinyl group-containing amino silicone derivatives of the present invention themselves can be used as bases for cosmetics, pharmaceutical preparations and various industrial materials.

When, for example, silicone oil having a low viscosity of 100 cs or less generally used in cosmetics and pharmaceutical preparations is used as a soft, homogeneous gel, the use of the mono-substituted compound in which a triazinyl group or a pyrimidinyl group of the amino silicone is substituted provides a gel-like composition not impairing refreshing feeling of the silicone oil. When used as a hard, homogeneous gel high in form retention, the di-substituted compound is mainly employed.

As described above, when the silicone derivatives are used in cosmetics and pharmaceutical preparations, it is preferred that halogen is removed by substitution, etc.

The silicone oil is used for various industrial materials utilizing its insulating properties and water repellency, and can be used properly by various selections according to its purpose of use as a gelling agent.

The gel-like compositions comprising the triazinyl group- or pyrimidinyl group-containing amino silicone derivatives of the present invention and silicone oil are

thermally reversible, and addition of DMSO to the gel-like compositions results in fluid liquids. From this fact, this gelation is deduced to be mainly caused by a hydrogen bond.

The present invention will be described in more detail with the following examples. It is understood of course that they are for the purpose of illustration only and are not intended to limit the scope of the invention.

EXAMPLE 1

Three grams (1.2×10^{-4} mol) of a side-chain amino silicone (BY16-849 manufactured by Dow Corning Toray Silicone Co., Ltd., MW: ca. 25000, amino equivalent: 600) dissolved in 20 g of benzene was mixed with 0.57 g (5.0×10^{-3} mol) of 2-chloropyrimidine previously dissolved in 20 g of benzene, and the mixture was stirred under reflux for 24 hours. After termination of the reaction, the solvent was removed by distillation under reduced pressure to obtain a 2-pyrimidinylorganopolysiloxane which has pyrimidinyl groups bound.

EXAMPLE 2

Thirty grams (6.6×10^{-3} mol) of a both-terminal amino silicone (BY16-853B manufactured by Dow Corning Toray Silicone Co., Ltd., MW: ca. 4500, amino equivalent: 2250) dissolved in 15 g of benzene was mixed with 2.46 g (13.3×10^{-3} mol) of cyanuric chloride previously dissolved in 15 g of benzene, and the mixture was stirred at room temperature for 24 hours. After termination of reaction,

the solvent was removed by distillation under reduced pressure, followed by washing with water. The resulting product was heated again under reduced pressure to remove the solvent by distillation, thereby mainly obtaining a triazinylorganopolysiloxane in which triazinyl groups were bound to both ends. This product showed the following nuclear magnetic resonance spectra:

Table 1

Structure Confirmation According to Nuclear Magnetic Resonance Spectra (^{13}C -NMR)

<u>Structure</u>	<u>Chemical Shift δ</u>
$\begin{array}{c} \parallel \\ \text{C}-\text{NH}-\text{R}-\text{Si}(\text{R})_3 \\ \end{array}$	166.1 ppm
$\begin{array}{c} \parallel \\ \text{C}-\text{Cl} \\ \end{array}$	169.9 ppm 171.1 ppm

Solvent: CDCl_3

EXAMPLE 3

3.1 g (1.24×10^{-4} mol) of a side-chain amino silicone (BY16-849 manufactured by Dow Corning Toray Silicone Co., Ltd., MW: ca.25000, amino equivalent: 600) dissolved in 50 g of 1,4-dioxane was mixed with 0.1 g (4.95×10^{-4} mol) of 2-chloro-4,6-bis(ethylamino)-s-triazine previously dissolved in 50 g of 1,4-dioxane, and the mixture was stirred under reflux at the boiling point for 24 hours. After termination of the reaction, the solvent was removed by distillation under reduced pressure to mainly obtain a 2-[4,6-bis(ethylamino)]-s-triazinylorganopoly-siloxane in

which 2-chloro-4,6-bis(ethylamino)-s-triazinyl groups were bound to a part of amino groups of one molecule of the side-chain amino silicone. This product showed the following nuclear magnetic resonance spectra:

Table 2

Structure Confirmation According to Nuclear Magnetic Resonance Spectra (^{13}C -NMR)

<u>Structure</u>	<u>Chemical Shift δ</u>
$-\underline{\text{C}}\text{H}_3$ (of an aminoethyl group)	15 ppm
$-\underline{\text{C}}\text{H}_2-$ (of an aminoethyl group)	35 ppm
$\begin{array}{c} \parallel \\ \underline{\text{C}}-\text{NH}-\text{R}-\text{Si}(\text{R})_3 \\ \end{array}$ (carbon of a triazinyl ring to which a silicone was bound)	163 ppm
$\begin{array}{c} \parallel \\ \underline{\text{C}}-\text{NH}-\text{CH}_2-\text{CH}_3 \\ \end{array}$ (carbon of a triazinyl ring to which an aminoethyl group was bound)	165 ppm

Solvent: CDCl_3

EXAMPLE 4

11.19 g (2.48×10^{-3} mol) of an α, ω -diamino silicone (BY16-843B manufactured by Dow Corning Toray Silicone Co., Ltd., MW: ca.4500, amino equivalent: 2250) dissolved in 150 g of 1,4-dioxane was mixed with 1 g (4.95×10^{-3} mol) of 2-chloro-4,6-bis(ethylamino)-s-triazine previously dissolved in 150 g of 1,4-dioxane, and the mixture was refluxed for 24 hours with stirring at 90°C . After termination of the reaction, the solvent was removed by distillation under

reduced pressure to obtain a 2-[4,6-bis(ethylamino)]-s-triazinylorganopolysiloxane in which 2-chloro-4,6-bis(ethylamino)-s-triazinyl groups were bound to both ends. This compound was highly viscous and paste-like.

EXAMPLE 5

0.22 g (1.19×10^{-3} mol) of cyanuric chloride dissolved in 20 g of benzene was mixed with 5.0 g (1.11×10^{-3} mol) of silicone oil having one amino end group (MW: ca. 4500), followed by stirring for 24 hours. After termination of the reaction, the solvent was removed by distillation under reduced pressure to mainly obtain a triazinylorganopolysiloxane in which one silicone chain was bound to a triazinyl group.

EXAMPLE 6

0.11 g (0.59×10^{-3} mol) of cyanuric chloride dissolved in 20 g of benzene was mixed with 5.0 g (1.11×10^{-3} mol) of silicone oil having one amino end group, BX16-193, followed by stirring for 24 hours. After termination of the reaction, the solvent was removed by distillation under reduced pressure to mainly obtain a triazinylorganopolysiloxane in which two silicone chains were bound to a triazine compound.

EXAMPLE 7

0.07 g (0.37×10^{-3} mol) of cyanuric chloride dissolved in 20 g of benzene was mixed with 5.0 g (1.11×10^{-3} mol) of silicone oil having one amino end group, BX16-193, followed

by stirring for 24 hours. After termination of the reaction, the solvent was removed by distillation under reduced pressure to mainly obtain a triazinylorganopolysiloxane in which three silicone chains were bound to a triazine compound.

EXAMPLE 8

Amino silicone derivatives (1) to (7) obtained in Examples 1 to 7 were each added to respective silicones so as to give a concentration of 10% by weight or 20% by weight, and dissolved by heating at room temperature or 80°C with stirring. The resulting solutions were each allowed to stand at room temperature, followed by observation. The gelling and viscosity increasing properties of the derivatives obtained in Examples 1 to 7 to the silicones are shown below.

Table 3

Sample	Concentration (%)	Silicone		
		No. 1	No. 2	No. 3
Example 1	10	Δ	Δ	Δ
	20	○	○	○
Example 2	10	⊙	⊙	⊙
	20	⊙	⊙	⊙
Example 3	10	Δ	Δ	Δ
	20	Δ	Δ	Δ
Example 4	10	Δ	Δ	Δ
	20	Δ	Δ	Δ
Example 5	10	○	⊙	Δ
	20	○	⊙	Δ
Example 6	10	⊙	⊙	⊙
	20	⊙	⊙	⊙
Example 7	10	○	○	Δ
	20	○	○	Δ

No. 1: dimethylpolysiloxane 5 cs

No. 2: dimethylpolysiloxane 50 cs

No. 3: decamethylcyclopentasiloxane 5 cs

⊙: gel (form retention kept)

○: weak gel

Δ: increase in viscosity

x: solution

The equivalent amount of DMSO was added to each gel of No. 1 obtained in Example 1, 2, 5, 6 or 7 shown in Table 3,

followed by stirring. As a result, each gel was turned solution-like. From this fact, this gel was deduced to be mainly made by a hydrogen bond.

The novel silicone derivatives of the present invention can be easily synthesized from the amino silicones and the triazine or pyrimidine compounds, and can gel silicone oil or increase the viscosity thereof stably and homogeneously. The gelled products are thermally reversible, and easily produced. Further, the resulting gels are transparent. The reason for this is deduced to be that this gel is mainly made by a hydrogen bond.

27580-104

- 37 -

CLAIMS:

1. A silicone derivative represented by the general formula (2):

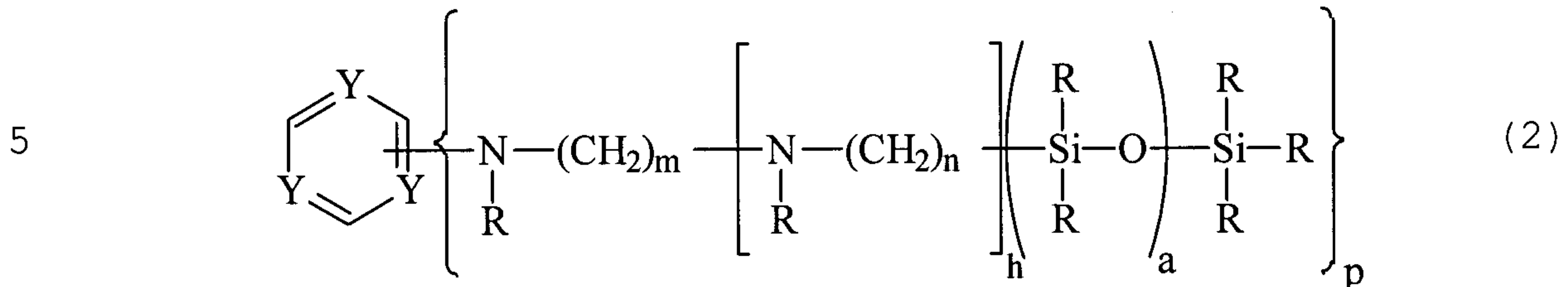

wherein:

each R, which may be the same or different, represents hydrogen or a linear, branched-chain or cyclic hydrocarbon group of 1 to 8 carbon atoms which may be substituted by halogen;

10

m and n each represent an integer of from 1 to 6;

h represents an integer of from 0 to 6;

"a" represents an integer of from 2 to 400;

15 at least two of Y are a nitrogen atom, and the remainder when present is a carbon atom;

p represents an integer of from 1 to 3 in the case of triazine, or from 1 to 4 in the case of pyrimidine; and

20 when p is 1 or 2 in the case of triazine, or 1, 2 or 3 in the case of pyrimidine, a hydroxyl group, an amino group which may be substituted by a linear or branched alkyl group of 1 to 6 carbon atoms, a halogen atom, a carboxyl group, a linear or branched alkyl group of 1 to 6 carbon atoms, or a linear or branched alkoxy group of 1 to 6 carbon atoms, as well as a hydrogen atom, may be bound to a residual carbon atom of the triazine ring or the pyrimidine ring.

25

27580-104

- 38 -

2. A silicone derivative represented by the general formula (3):

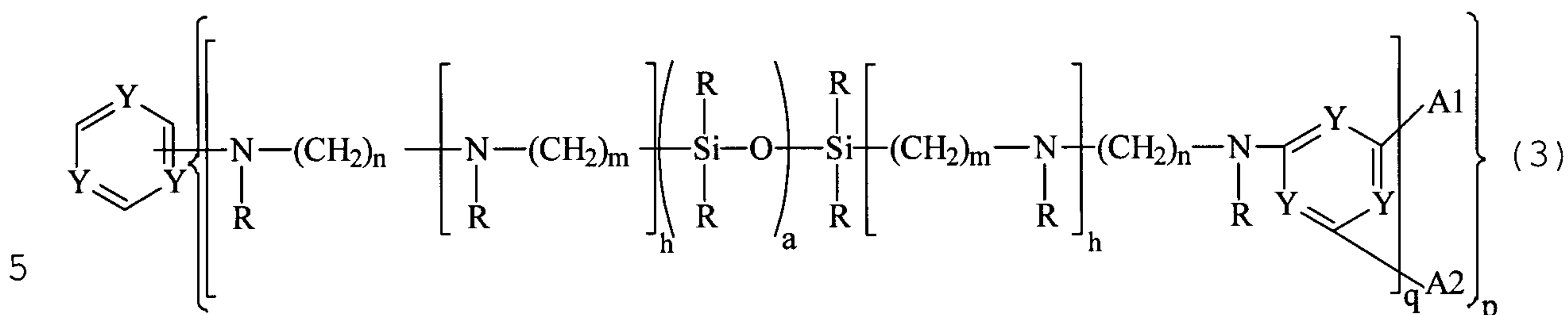

wherein:

each R, which may be the same or different, represents hydrogen or a linear, branched-chain or cyclic hydrocarbon group of 1 to 8 carbon atoms which may be substituted by halogen;

10

m and n each represent an integer of from 1 to 6;

h represents an integer of from 0 to 6;

"a" represents an integer of from 2 to 400;

at least two of Y are a nitrogen atom, and the remainder when present is a carbon atom;

15

q represents an integer of from 0 to 10;

p represents an integer of from 1 to 3 in the case of triazine, or from 1 to 4 in the case of pyrimidine; and

when p is 1 or 2 in the case of triazine, or 1, 2 or 3 in the case of pyrimidine, a hydroxyl group, an amino group which may be substituted by a linear or branched alkyl group of 1 to 6 carbon atoms, a halogen atom, a carboxyl group, a linear or branched alkyl group of 1 to 6 carbon atoms, or a linear or branched alkoxy group of 1 to 6 carbon atoms, as well as a hydrogen atom, may be bound to a residual carbon atom of the triazine ring or the pyrimidine ring;

20

25

27580-104

- 39 -

(i) when q is from 1 to 10, A1 and A2 are each represented by a group of the general formula (4):

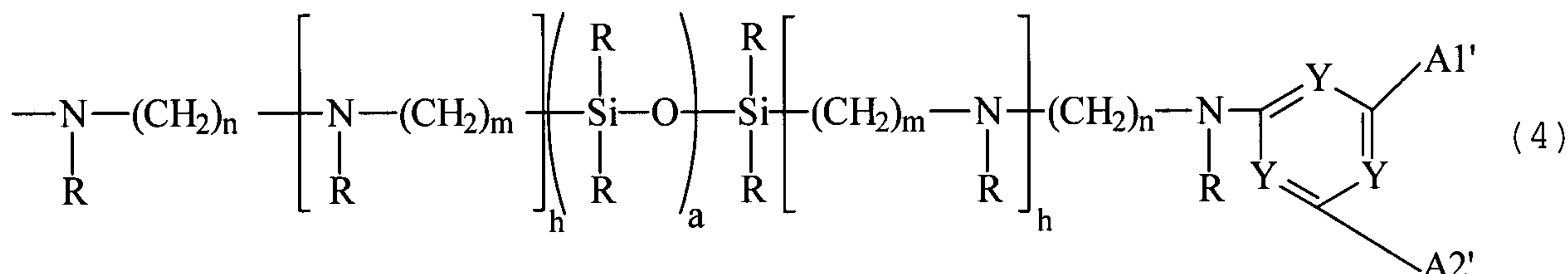

5

wherein R, m, n, h, "a" and Y have the same meanings as given above; and A1' and A2' each represent a hydrogen atom, a hydroxyl group, an amino group which may be substituted by a linear or branched alkyl group having 1 to 6 carbon atoms, a halogen atom, a carboxyl group, a linear or branched alkyl group having 1 to 6 carbon atoms, or a linear or branched alkoxy group having 1 to 6 carbon atoms; or

A1 and A2 are each represented by a group of the general formula (5):

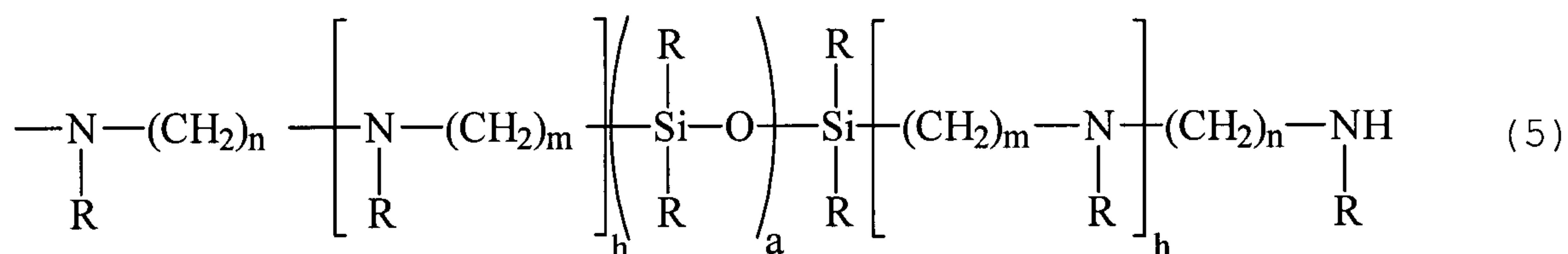

15

wherein R, m, n, h and "a" have the same meanings as given above; or

A1 and A2 each represent a hydrogen atom, a hydroxyl group, an amino group which may be substituted by a linear or branched alkyl group having 1 to 6 carbon atoms, a halogen atom, a carboxyl group, a linear or branched alkyl group having 1 to 6 carbon atoms, or a linear or branched alkoxy group having 1 to 6 carbon atoms; and

25

27580-104

- 40 -

(ii) when q is 0, the general formula (3) is represented by the general formula (6):

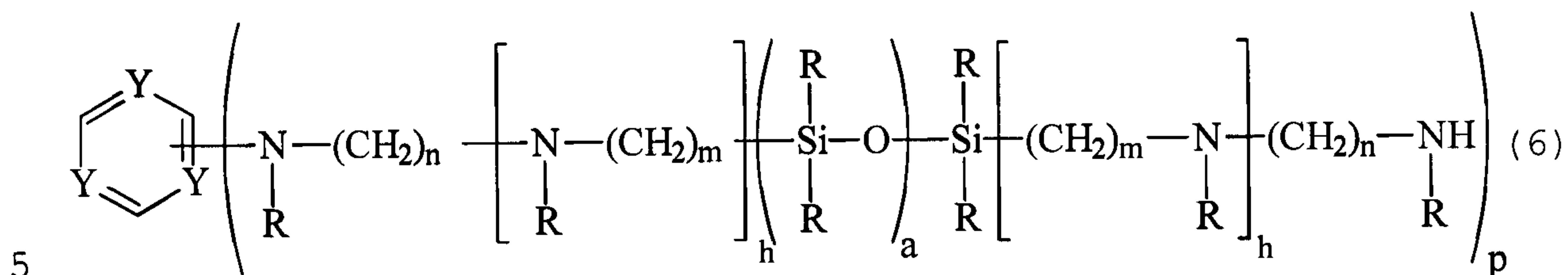

wherein R, m, n, h, "a", Y and p have the same meanings as given above.

3. A silicone derivative represented by general formula (7), which is obtained by allowing a side-chain amino silicone to react with a reactive group-containing triazine or pyrimidine compound:

10

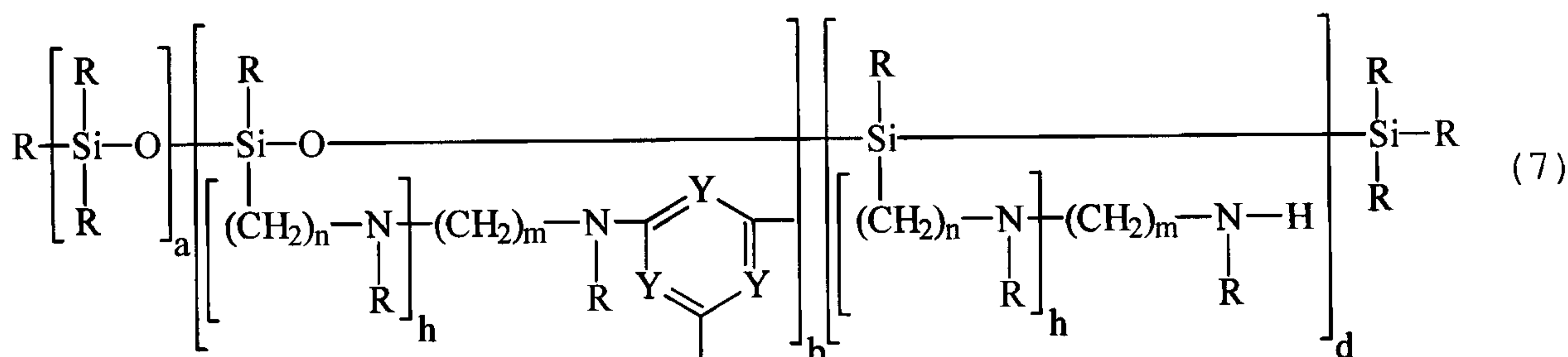

15 wherein:

each R, which may be the same or different, represents hydrogen or a linear, branched-chain or cyclic hydrocarbon group of 1 to 8 carbon atoms which may be substituted by halogen;

20 m and n each represent an integer of from 1 to 6;

h represents an integer of from 0 to 6;

"a" and "b" each represent an integer of 1 or more, "d" represents an integer of 0 or more, and "a+b+d" represents an integer of 400 or less, where "a", "b" and "d" each show a ratio, and do not specify the order of arrangement; and

25

27580-104

- 41 -

at least two of Y are a nitrogen atom, and the remainder when present is a carbon atom.

4. The silicone derivative according to claim 1, wherein "a" is an integer of from 10 to 300.

5. The silicone derivative according to claim 1 or 4, wherein p is 1.

6. The silicone derivative according to claim 1, 4 or 5, wherein

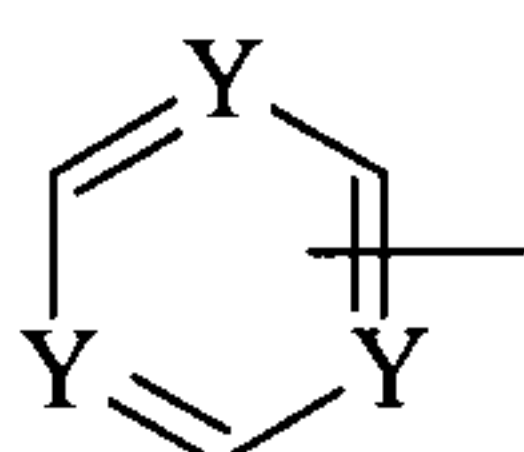

is derived from a triazine compound

10 selected from the group consisting of cyanuric chloride, 2-chloro-4,6-bis(methylamino)-S-triazine, 2-chloro-4,6-bis(ethylamino)-S-triazine (simazine), 2-chloro-4,6-bis(propylamino)-S-triazine, 2-chloro-4,6-bis(butyl-amino)-S-triazine, 2-chloro-4,6-bis(amylamino)-S-triazine,
 15 2-chloro-4-methylamino-6-ethylamino-S-triazine, 2-chloro-4-methylamino-6-propylamino-S-triazine, 2-chloro-4-ethylamino-6-isopropylamino-S-triazine (atrazine), 2-chloro-4-ethylamino-6-propylamino-S-triazine, 2-chloro-4-ethyl-amino-6-isobutylamino-S-triazine, 2-chloro-4-propylamino-6-
 20 isopropylamino-S-triazine, 2-chloro-4,6-bis(ethoxy)-S-triazine, 2-chloro-4,6-bis(methoxy)-S-triazine, 2-chloro-4,6-bis(propoxy)-S-triazine and 2-chloro-4,6-bis(butoxy)-S-triazine.

7. The silicone derivative according to claim 1, 4
 25 or 5, wherein

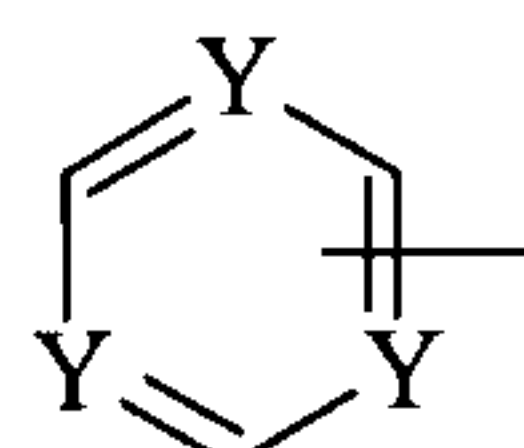

is derived from a pyrimidine compound

selected from the group consisting of 2-chloropyrimidine, 2-chloro-4,6-dimethylpyrimidine, 2-chloro-4,6-

27580-104

- 42 -

(dimethylamino)pyrimidine, 2,5-dichloro-4-methoxy-6-trichloromethylpyrimidine and 2,4,5,6-tetra-chloropyrimidine.

8. The silicone derivative according to claim 2, wherein q is from 1 to 10.

5 9. The silicone derivative according to claim 8, wherein A1 and A2 are each represented by the group of the formula (4).

10. The silicone derivative according to claim 8, wherein A1 and A2 are each represented by the group of the
10 formula (5).

11. The silicone derivative according to claim 8, wherein A1 and A2 each represent a hydrogen atom, a hydroxyl group, an amino group which may be substituted by a linear or branched alkyl group having 1 to 6 carbon atoms, a
15 halogen atom, a carboxyl group, a linear or branched alkyl group having 1 to 6 carbon atoms or a linear or branched alkoxy group having 1 to 6 carbon atoms.

12. The silicone derivative according to claim 2, wherein q is 0.

20 13. The silicone derivative according to claim 2 or any one of claims 8 to 12, wherein "a" is an integer of from 10 to 300.

14. The silicone derivative according to claim 2 or any one of claims 8 to 13, wherein p is 1.

25 15. The silicone derivative according to claim 3, wherein "a+b+d" is an integer of from 10 to 300.

16. The silicone derivative according to claim 3 or 15, wherein h is 0.

27580-104

- 43 -

17. The silicone derivative according to claim 3 or 6, wherein h is an integer of from 1 to 6.

18. The silicone derivative according to any one of claims 1 to 17, wherein each R attached to Si is a linear, 5 branched-chain or cyclic hydrocarbon group of 1 to 8 carbon atoms.

19. The silicone derivative according to any one of claims 1 to 17, wherein each R attached to Si is methyl or phenyl.

10 20. The silicone derivative according to any one of claims 1 to 19, wherein each R attached to N is hydrogen.

21. The silicone derivative according to any one of claims 1 to 20, which is free of halogen.

22. A method for producing the silicone derivative 15 represented by the formula (2) defined in claim 1, the formula (3) defined in claim 2 or the formula (7) defined in claim 3, which comprises reacting an amino silicone oil represented by the following general formula (8):

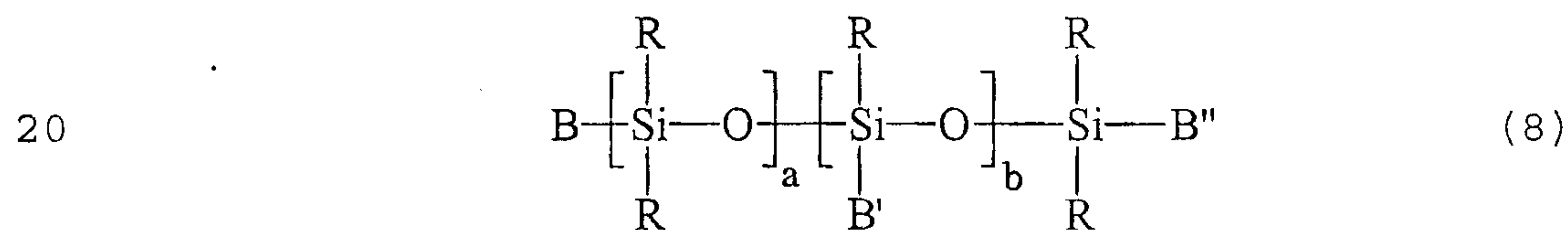

(wherein R is as defined in claim 1, 2 or 3; "a" and "b" each represent an integer of 1 or more, and the sum of "a" and "b" represents an integer of 400 or less; "a" and "b" 25 each show a ratio, and do not specify the order of arrangement; and at least one of B, B' and B'' is a group represented by general formula (9):

27580-104

- 44 -

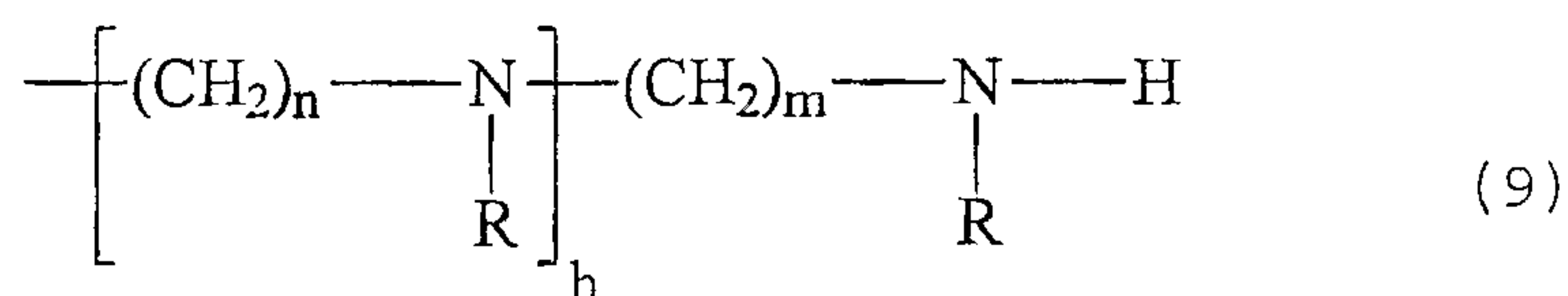

wherein R, m, n and h are as defined in claim 1, 2 or 3, and
 5 the remainder of B, B' and B'' when present represent R);

with a reactive group-containing triazine or
 pyrimidine compound represented by the following general
 formula (10):

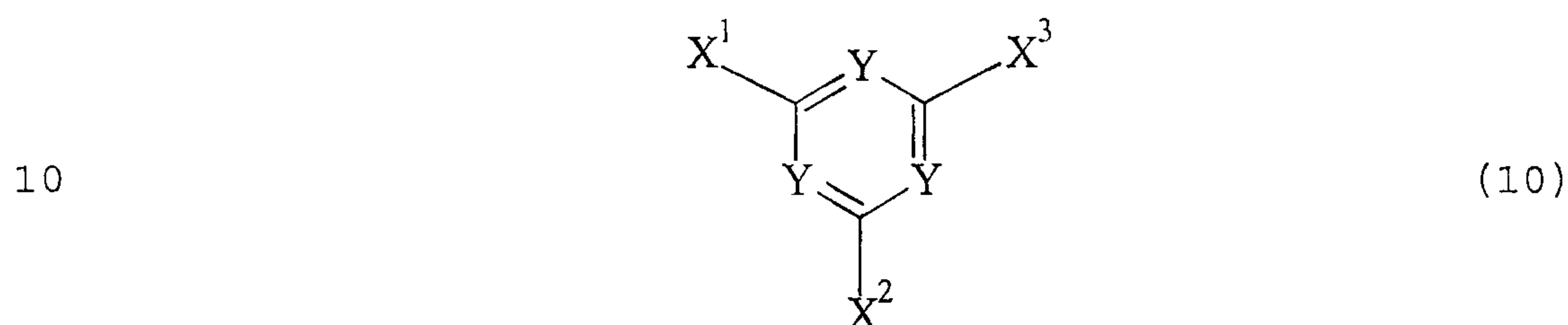

(wherein at least one of X¹, X² and X³ represents a halogen
 atom, the remainder when present represent a hydrogen atom,
 a hydroxyl group, an amino group which may be substituted by
 15 a linear or branched alkyl group having 1 to 6 carbon atoms,
 a carboxyl group, a linear or branched alkyl group having 1
 to 6 carbon atoms, or a linear or branched alkoxy group
 having 1 to 6 carbon atoms; and at least two of Y are a
 nitrogen atom, and the other when present is a carbon atom).

20 23. The method according to claim 22, wherein the
 amino silicone oil is an amino silicone having one end group
 represented by the formula:

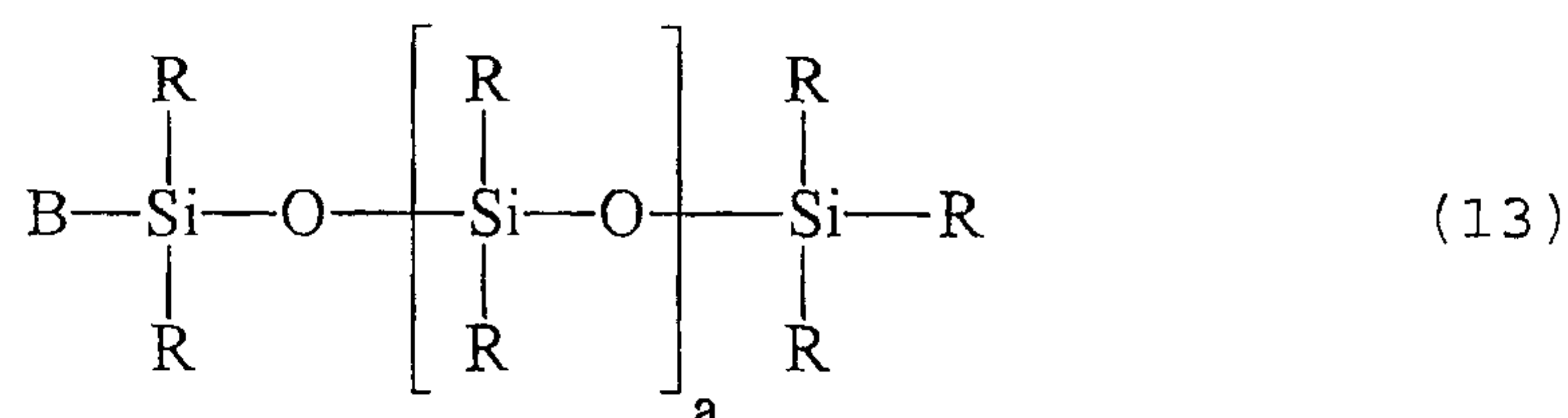

25

wherein R and "a" are as defined in claim 22.

27580-104

- 45 -

24. The method according to claim 22, wherein the amino silicone oil is an α,ω -diamino silicone represented by the formula:

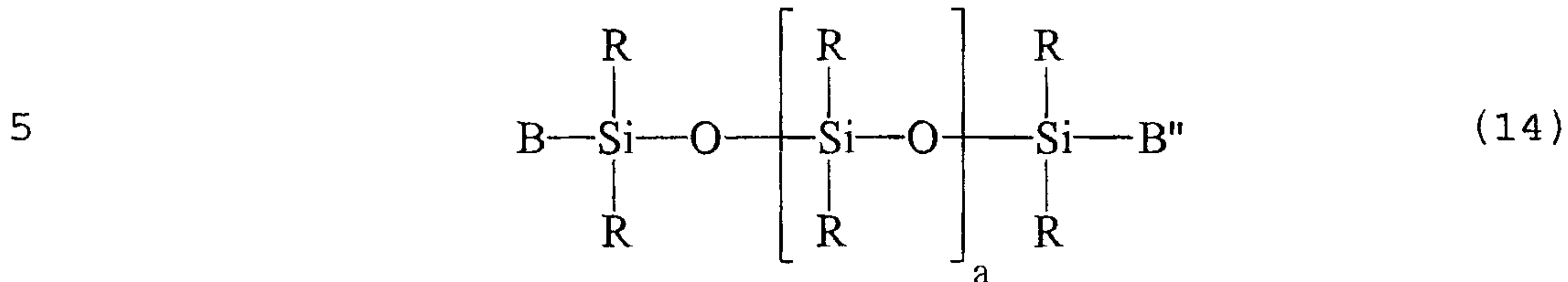

wherein R and "a" are as defined in claim 22 and B and B'' each represent the group of the formula (9).

25. The method according to claim 22, wherein the amino silicone oil is a side-chain amino silicone represented by the formula:

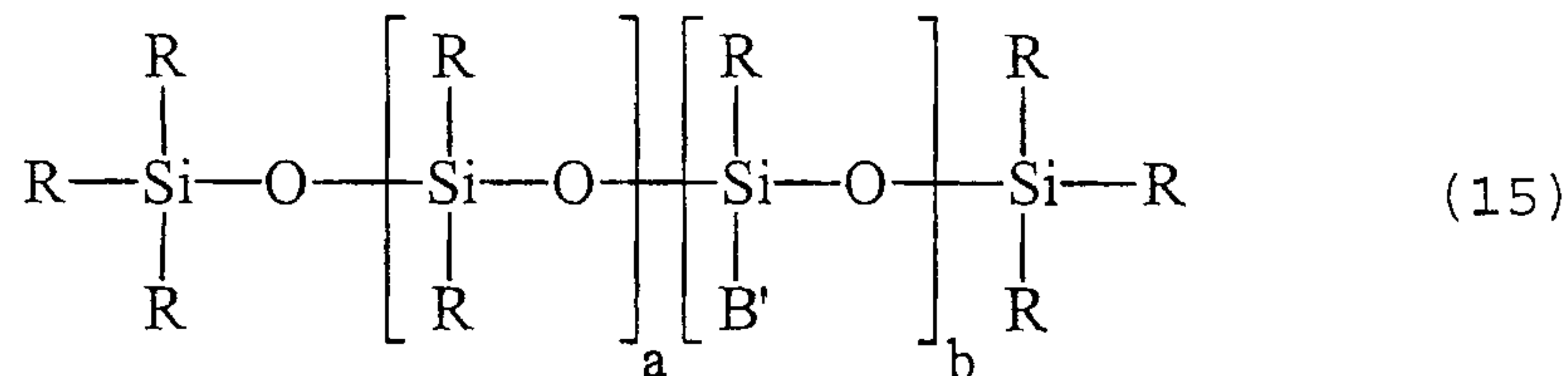

wherein R, "a" and "b" are as defined in claim 22 and B' represents the group of the formula (9).

26. The method according to any one of claims 22 to 25, wherein the amino silicone oil has an amino equivalent of 500 to 5,000 and a molecular weight of 1,000 to 20,000.

27. The method according to any one of claims 22 to 26, wherein the amino silicone oil represented by the general formula (8) is reacted with the reactive group-containing triazine compound represented by the general formula (10) in which all three Y groups are a nitrogen atom.

28. The method according to claim 27, wherein the reactive group-containing triazine compound is a member selected from the group consisting of cyanuric chloride,

27580-104

- 46 -

2-chloro-4,6-bis(methylamino)-S-triazine, 2-chloro-4,6-bis(ethylamino)-S-triazine (simazine), 2-chloro-4,6-bis(propylamino)-S-triazine, 2-chloro-4,6-bis(butyl-amino)-S-triazine, 2-chloro-4,6-bis(amylamino)-S-triazine,
 5 2-chloro-4-methylamino-6-ethylamino-S-triazine, 2-chloro-4-methylamino-6-propylamino-S-triazine, 2-chloro-4-ethylamino-6-isopropylamino-S-triazine (atrazine), 2-chloro-4-ethylamino-6-propylamino-S-triazine, 2-chloro-4-ethylamino-6-isobutylamino-S-triazine, 2-chloro-4-propylamino-6-
 10 isopropylamino-S-triazine, 2-chloro-4,6-bis(ethoxy)-S-triazine, 2-chloro-4,6-bis(methoxy)-S-triazine, 2-chloro-4,6-bis(propoxy)-S-triazine and 2-chloro-4,6-bis(butoxy)-S-triazine.

29. The method according to any one of claims 22 to 26,
 15 wherein the amino silicone oil represented by the general formula (8) is reacted with the reactive group-containing pyrimidine compound represented by the general formula (10) in which two Y groups are a nitrogen atom and one Y group is a carbon atom.

20 30. The method according to claim 29, wherein the reactive group-containing pyrimidine compound is selected from the group consisting of 2-chloropyrimidine, 2-chloro-4,6-dimethylpyrimidine, 2-chloro-4,6-(dimethylamino)pyrimidine, 2,5-dichloro-4-methoxy-6-
 25 trichloromethylpyrimidine and 2,4,5,6-tetra-chloropyrimidine.

31. A method for gelling a liquid silicone oil, which comprises adding the silicone derivative as defined in any one of claims 1 to 21 to the liquid silicone oil.

32. A composition comprising:

27580-104

- 47 -

the silicone derivative as defined in any one of claims 1 to 21, and

a silicone oil or a liquid oil.

33. A pharmaceutical preparation which comprises:

5 the silicone derivative as defined in any one of claims 1 to 21; and

a pharmaceutically active component.

34. A cosmetic preparation which comprises:

10 the silicone derivative as defined in any one of claims 1 to 21; and

a cosmetically active component.

35. Use of the silicone derivative as defined in any one of claims 1 to 21 as a base for a textile treating agent, a surface lubricant, a water repelling agent, a resin
15 modifier, a paint additive, an electrical insulating agent, a heat medium, a grease, an oil for machinery, a foam stabilizer, an anti-foam agent, a water repelling agent, a potting agent for an electric or electronic part, a vibration absorbing agent for a damper, a thickener, a
20 sealing agent or a pigment dispersing agent.

36. A method for increasing the viscosity of a liquid silicone oil, which comprises adding the silicone derivative as defined in any one of claims 1 to 21 to the liquid silicone oil.

25 37. The method according to claim 36, wherein the liquid silicone oil has a viscosity of 100 cs or less before the silicone derivative is added thereto.

27580-104

- 48 -

38. A method for increasing the viscosity of a liquid hydrocarbon oil, which comprises adding the silicone derivative as defined in any one of claims 1 to 21 to the liquid hydrocarbon oil which is compatible with the silicone
5 derivative.

39. The method according to claim 38, wherein the liquid hydrocarbon oil is isoparaffin oil or an ester oil.

FETHERSTONHAUGH & CO.

OTTAWA, CANADA

PATENT AGENTS

