

(12) PATENT
(19) AUSTRALIAN PATENT OFFICE

(11) Application No. AU 199748095 B2
(10) Patent No. 734480

(54) Title
Apparatus and method for reducing breakage of fibers drawn from blanks

(51)⁶ International Patent Classification(s)
C03B 029/02 C03B 037/027

(21) Application No: 199748095 (22) Application Date: 1997 .10 .03

(87) WIPO No: W098/18733

(30) Priority Data

(31) Number	(32) Date	(33) Country
60/029318	1996 .10 .25	US

(43) Publication Date : 1998 .05 .22
(43) Publication Journal Date : 1998 .07 .16
(44) Accepted Journal Date : 2001 .06 .14

(71) Applicant(s)
Corning Incorporated

(72) Inventor(s)
Julian L. Dunn; G. Scott Glaesemann; James E. Dickinson Jr.; Bruce
W. Reding; James A. Snipes; Donald J. Wissuchek Jr.

(74) Agent/Attorney
PHILLIPS ORMONDE and FITZPATRICK,367 Collins Street,MELBOURNE VIC 3000

(56) Related Art
US 4236930

OPI DATE 22/05/98 APPLN. ID 48095/97
AOJP DATE 16/07/98 PCT NUMBER PCT/US97/18041



AU9748095

(CT)

(51) International Patent Classification ⁶ : C03B 29/02, 37/027	A1	(11) International Publication Number: WO 98/18733 (43) International Publication Date: 7 May 1998 (07.05.98)
(21) International Application Number: PCT/US97/18041 (22) International Filing Date: 3 October 1997 (03.10.97) (30) Priority Data: 60/029,318 25 October 1996 (25.10.96) US (71) Applicant (for all designated States except US): CORNING INCORPORATED [US/US]; 1 Riverfront Plaza, Corning, NY 14831 (US). (71)(72) Applicants and Inventors: DUNN, Julian, L. [US/US]; 1228 Boyden Place, Concord, NC 28027 (US). GLAESE-MANN, G., Scott [US/US]; 1039 John Hill Road, Corning, NY 14830 (US). (72) Inventors; and (75) Inventors/Applicants (for US only): DICKINSON, James, E., Jr. [US/US]; 202 Wall Street, Corning, NY 14830 (US). REDING, Bruce, W. [US/US]; 423 Wendover Lane, Wilmington, NC 28405 (US). SNIPES, James, A. [US/US]; 6303 Strawfield Drive, Wilmington, NC 28405 (US). WIS-SUCHEK, Donald, J., Jr. [US/US]; 12 Algonquin Drive, Horseheads, NY 14845 (US).	(74) Agent: HERZFELD, Alexander R.; Corning Incorporated, Patent Dept., SP FR 01-12, Corning, NY 14831 (US). (81) Designated States: AU, CA, JP, US, European patent (AT, BE, CH, DE, DK, ES, FI, FR, GB, GR, IE, IT, LU, MC, NL, PT, SE). Published <i>With international search report.</i>	

(54) Title: APPARATUS AND METHOD FOR REDUCING BREAKAGE OF FIBERS DRAWN FROM BLANKS

(57) Abstract

A fiber preform (20) is contaminated with contaminates such as silicon nitride or silicon carbide. The preform is then held in a chamber (10) with a reducing gas (29) being introduced into the chamber. The reducing gas prevents the contaminates from being oxidized. If the contaminates were oxidized, the strength of the final fiber would be reduced.

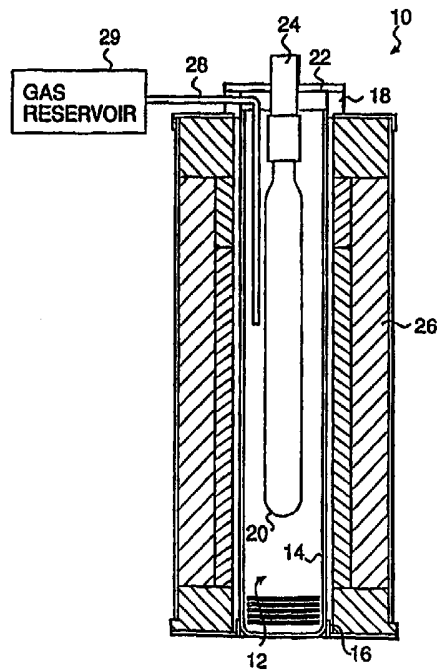

APPARATUS AND METHOD FOR REDUCING BREAKAGE OF FIBERS
DRAWN FROM BLANKS

FIELD OF THE INVENTION

5

The present invention relates to an apparatus and method for reducing breakage of a fiber drawn from a blank and, more particularly, to a holding oven and method that inhibit passive oxidation of a contaminant of a silica-containing blank and/or that minimize surface contamination of the blank.

10

DESCRIPTION OF THE RELATED ART

The discussion of the background to the invention herein is included to explain the context of the invention. This is not to be taken as an admission that any of the material referred to was published, known or part of the common general knowledge in Australia as at the priority date of any of the claims.

15

Optical waveguide fibers (optical fibers) are a transmission medium used in optical communication systems. Optical fibers are typically made by well known methods

20



that involve forming blanks from which the fibers are to be drawn, storing the blanks in holding ovens, and drawing fibers from the blanks in draw furnaces.

5 Strength is an important characteristic of optical fibers. Particulate contaminants on the fiber surface often weaken the fiber and cause flaw initiation and fiber failure under tensile loading. Some optical fibers break under low stress due to such contaminants.

10 This breakage problem is addressed in U.S. Provisional Application No. 60/029,469 by J.E. Dickinson, D.J. Wissuchek, J.A. Snipes, G.S. Glaesemann, and T. Tao and entitled Apparatus and Method for Reducing Break Sources in Drawn Fibers, the disclosure of which is hereby incorporated by reference.

15 Briefly, the provisional application discloses that breaking fibers contain silicon carbide (SiC) and silicon nitride (Si₃N₄), which are non-oxide, refractory contaminants. These contaminants are in the size range typical of airborne particles (less than 5 μm) and attach
20 to the surface of the blank before or during the drawing process, thus producing a draw trough on the surface of the fiber.

25 These contaminants have an adhered passivation layer of amorphous silica formed thereon. The passivation layer is a solid reaction product of passive oxidation. The passive oxidation mechanisms for silicon carbide and

SUBSTITUTE SHEET (RULE 20)

silicon nitride are represented by the following formulas:

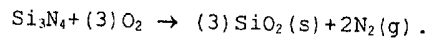
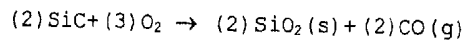

5 These passivation-layered contaminants act as low-stress break sources for the optical fibers.

The provisional application also discloses that the contaminants can be removed by active oxidation. In contrast to the passive oxidation mechanism, the active oxidation mechanism produces a gaseous reaction product and causes corrosion of the silicon carbide and silicon nitride contaminants. The active oxidation mechanisms for silicon carbide and silicon nitride are represented by the following formulas:

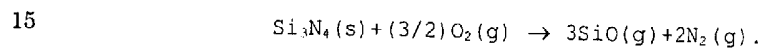
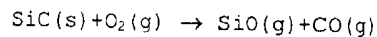

The draw process described in the provisional application promotes active oxidation of the contaminants by providing a low-oxygen environment during drawing.

20 Additionally, the environment of the manufacturing plant may contain particulate contaminants, such as airborne particles of zirconium (Zr) compounds such as zirconia (ZrO₂) and calcium (Ca) compounds, that may become attached to the surface of the blank while it is being transferred to the holding oven and/or while it is being held in the holding oven. The zirconia contaminants are

25

SUBSTITUTE SHEET (RULE 20)

typically about 5 to 10 μm and the contaminants of calcium compounds are typically about 2 to 3 μm . If these environmental contaminants are allowed to remain on the surface of the blank, they can weaken fiber drawn from the blank and cause fiber failure under tensile loading.

5

SUMMARY OF THE INVENTION

According to the present invention, there is provided a method for storing a blank having a refractory contaminant before use in a drawing device in which a fiber is to be drawn from the blank, including the steps of:

disposing the blank in a holding device; and

providing an environment in the holding device that inhibits passive oxidation of the contaminant.

The present invention also provides an apparatus adapted to store a blank having a refractory contaminant before use in a drawing device in which a fiber is to be drawn from the blank, including:

a compartment for storing the blank; and

a supply device that supplies gas to the compartment to provide an environment in the compartment that inhibits passive oxidation of the contaminant.

The present invention further provides a method of producing a fiber from a blank having an oxidizable, refractory contaminant, including the steps of:

storing the blank in a holding device having an environment that inhibits passive oxidation of the contaminant;

disposing the blank in a drawing portion of a drawing device having an environment that promotes active oxidation of the contaminant; and

drawing a fiber from the blank in the drawing portion.

The present invention still further provides a system for producing fiber from a blank having an oxidizable, refractory contaminant, including:

a compartment for storing the blank;

a supply device that supplies gas to the compartment to provide an environment in the compartment that inhibits passive oxidation of the contaminant;



4a

a drawing portion for heating the blank to a fiber drawing temperature;
and

a supply device that supplies gas to the drawing portion to provide an environment in the drawing portion that causes active oxidation of the
5 contaminant.

The present invention still further provides a method of producing a fiber from a member having an oxidizable, refractory contaminant, including the steps of:

10 inhibiting passive oxidation of the contaminant;
promoting active oxidation of the contaminant; and
forming a fiber from the member in a forming portion of a forming device having a refractory oxide component in the forming portion.

The present invention still further provides a method of storing a blank before use in a drawing device in which a fiber is to be drawn from the blank,
15 including the steps of:

20 disposing the blank in a holding device; and
flowing a gas against a surface of the blank in the holding device at a rate sufficient to prevent an environmental contaminant from becoming attached to the surface of the blank.

An advantage of the present invention is an improvement of the efficiency of the active oxidation drawing process.

Another advantage of the invention is the facilitation of removal of contaminants in the active oxidation drawing process by inhibiting passive oxidation of contaminants before commencement of the process.

25 Yet another advantage of the invention is the ability to minimize surface contamination of a blank by environmental contaminants.

Additional objects and advantages of the invention will become apparent from the description which follows. Additional advantages may also be learned by practice of the invention.

30 As explained more fully below, it has been discovered that conventional holding ovens may passively oxidize contaminants of blanks and, thereby, cause the formation of a passivation layer on the contaminants. This passivation layer can inhibit corrosion of the



contaminants in the active oxidation drawing process. The present invention is designed to improve the efficiency of the active oxidation drawing process by inhibiting passive oxidation of the contaminants and the corresponding
5 formation of passivation layers, before commencement of the active oxidation drawing process.

In a broad aspect, the invention provides an improved method of storing a blank having a refractory contaminant before use in a drawing device in which a fiber is to be
10 drawn from the blank, comprising the steps of disposing the blank in a holding device, and providing an environment in the holding device that inhibits passive oxidation of the refractory contaminant.

In another broad aspect, the invention provides an
15 improved apparatus for storing a blank having a refractory contaminant before use in a drawing device in which a fiber is to be drawn from the blank, comprising a compartment for storing the blank, and a supply device that supplies gas to the compartment to provide an
20 environment in the compartment that inhibits passive oxidation of the refractory contaminant.

In yet another broad aspect, the invention provides an improved method of storing a blank before use in a drawing device in which a fiber is to be drawn from the
25 blank, comprising the steps of disposing the blank in a holding device, and flowing a gas against a surface of the

SUBSTITUTE SHEET (RULE 20)

6

blank in the holding device at a rate sufficient to prevent an environmental contaminant from becoming attached to the surface of the blank.

5 It is to be understood that both the foregoing summary and the following detailed description are exemplary and explanatory only and are not restrictive of the invention, as claimed.

10 BRIEF DESCRIPTION OF THE DRAWINGS

The invention will be described in conjunction with the accompanying drawings, which illustrate presently preferred embodiments of the invention.

15 FIG. 1 is a sectional view of a first embodiment of a holding oven according to the present invention.

FIG. 2 is a sectional view of a draw furnace.

20 FIG. 3 is a graphic illustration of the transition between the passive and active oxidation mechanisms for silicon carbide.

25 FIG. 4 is a graphic illustration of the growth of a passivation layer on silicon carbide.

SUBSTITUTE SHEET (RULE 28)

7

FIG. 5 is a graphic illustration of the growth of a passivation layer on silicon nitride.

5 FIG. 6 is a sectional view of a second embodiment of a holding oven according to the present invention.

FIG. 7 is a top view of a top ring in the holding oven shown in FIG. 6.

10

DESCRIPTION OF THE PREFERRED EMBODIMENT

Reference will now be made in detail to the preferred embodiments of the invention illustrated in the drawings.

15 It has been discovered, in connection with the present invention, that a passivation layer formed on a silicon carbide or silicon nitride contaminant before a blank enters the draw furnace may inhibit corrosion of the contaminant by active oxidation in the active oxidation drawing process. The passivation layer hinders the
20 reaction by creating a diffusive barrier for oxidation reactants and products. For example, the reaction rate for the corrosion of silicon carbide and silicon nitride is governed by the rate of diffusion of carbon monoxide or nitrogen through the passivation layer.

25

Thus, for blanks having a contaminant with a passivation layer, the draw process must supply sufficient time under active oxidation conditions to ablate the

SUBSTITUTE SHEET (RULE 28)

contaminant with its passivation layer. If the passivation layer is sufficiently thick, the active oxidation drawing process may not fully remove the contaminant or may remove it so slowly that the process is not practical.

It has also been discovered, in connection with the present invention, that the environment of a conventional holding oven promotes passive oxidation of refractory contaminants and causes the formation of passivation layers before commencement of the drawing process.

The boundary between the passive and active oxidation mechanisms depends on the oxygen concentration and temperature. In FIG. 3, line 70 indicates the experimentally-determined boundary between the passive and active oxidation mechanisms for silicon carbide within specified ranges of partial pressure of oxygen (P_{O_2}) and temperature. FIG. 3 also shows the results of an experiment that illustrate the active/passive transition. Samples of silicon carbide (greater than 99.9% pure processed mirror finish, Morton Advanced Materials, Woburn, MA) and silicon nitride (hot pressed sheet, matte finish), were placed in contact with silica and heated at temperatures ranging from approximately 1200°C to 1500°C in a high-oxygen environment of ambient air ($P_{O_2} = 0.2$) and a low-oxygen environment of flowing helium ($P_{O_2} = 10^{-5}$). In the high-oxygen environment, all samples exhibited a

SUBSTITUTE SHEET (RULE 28)

characteristic of passive oxidation (i.e., film growth).
In the low-oxygen environment, the behavior of samples
varied depending on temperature. Samples heated to 1450°C
or higher exhibited a characteristic of active oxidation
5 (i.e., heavy etching of the mirror finish (3A rms surface
finish) of the silicon carbide). Samples held below
approximately 1300°C did not exhibit a characteristic of
active oxidation (i.e., they had pristine, unetched
surfaces).

10 As can be seen from FIG. 3, the environment of a
conventional holding oven (ambient air maintained at
approximately 950°C) is well within the passive region and
promotes passive oxidation. Accordingly, conventional
holding ovens cause the formation of the undesirable
15 passivation layer on silicon carbide and silicon nitride
contaminants before commencement of the drawing process.

In contrast to conventional holding ovens, the
present invention inhibits the formation of a passivation
layer by providing an environment in the holding oven that
20 inhibits passive oxidation. Preferably, passive oxidation
is inhibited by providing an environment that is
substantially devoid of oxygen. Such an environment can
be provided, for example, by replacing ambient air with
argon (Ar) or nitrogen (N₂). The dearth of oxygen causes
25 the passive oxidation mechanism to become essentially
inactive.

SUBSTITUTE SHEET (RULE 26)

10

The following experiment illustrates this advantage of the present invention. The conditions in a conventional holding oven were simulated by providing an environment, in an electrically heated oven, of ambient
5 air at a constant temperature of 950°C. Samples (each approximately 3 mm x 5 mm) of silicon carbide and silicon nitride were placed in the environment and were removed after hold times of 6 hours, 24 hours, 2 days, 3 days, and
10 5 days. The silicon carbide samples had color changes on their mirror surfaces due to thin film growth. After 6 hours, the film began to nucleate at grain boundaries on the silicon carbide surface. At 24 hours, the grain boundaries and several complete grains were covered. At
15 48 hours, approximately 90% of the grains were completely oxidized. The remaining grains remained unoxidized due to crystal orientation effects on oxide growth rate. Film growth on the silicon nitride samples was not optically visible due to the matte finish of the samples, but was detected by other means.

20 The thicknesses of the films on the surface of the silicon carbide and silicon nitride samples were measured by depth profiling using electron spectroscopy for chemical analysis (ESCA). This technique confirmed that
25 the thin films were silica passivation layers. The passivation layers were sputtered using an argon ion beam, and the sputtering continued until the carbon (for silicon

SUBSTITUTE SHEET (RULE 20)

carbide) or nitrogen (for silicon nitride) signal became prevalent. The thicknesses of the passivation layers were calculated using an approximate sputter rate of 50 angstroms/minute for silica.

5 FIGS. 4 and 5 show the growth rates for the passivation layers formed on the silicon carbide and silicon nitride samples, respectively. The parabolic growth rates of the passivation layers are typical of rates that are limited by diffusion of the reacting
10 species across a thickening reaction layer. The growth rate equations are:

$$r = 0.025\sqrt{t} \text{ (silicon carbide)}$$

15 $r = 0.166\sqrt{t} \text{ (silicon nitride)}$

where r is the thickness of the passivation layer in microns, and t is the hold time (at 950°C) in hours.

In contrast, the conditions in holding ovens
20 according to the present invention were simulated by providing environments substantially devoid of oxygen. Argon and nitrogen were each used as purge gases to provide the low-oxygen environments. Silica, silicon carbide, and silicon nitride samples were placed in
25 flowing gas at 950°C for periods of 3 days and 6 days. Oxygen levels were monitored continuously during the experiment, with P_{O_2} being less than 1 part per million (ppm) for the argon environment and approximately 80 ppm

SUBSTITUTE SHEET (RULE 20)

for the nitrogen environment. In all cases, the surfaces of the samples remained pristine and there was no evidence of silica film growth (i.e., a passivation layer). In other words, the low-oxygen environment inhibited the
5 formation of a passivation layer. In addition, silica and nitrogen did not react to form silicon nitride.

The first embodiment of a holding oven according to the present invention is shown in FIG. 1 and is designated generally by reference numeral 10. Holding oven 10 is a
10 conventional holding oven that has been modified to provide an environment that inhibits passive oxidation of contaminants. In accordance with the invention, holding oven 10 includes a compartment for storing a blank, and a supply device that supplies gas to the compartment to
15 provide an environment in the compartment that inhibits passive oxidation of a refractory contaminant of the blank.

As shown herein, the compartment 12 for storing blank
20 includes a muffle 14 that is centered by centering ring 16 and top seal 18. The top of compartment 12 is covered by a top seal 18 and a cover 22. A handle 24 extends through cover 22 to hold blank 20. Heaters and insulation
26 maintain compartment 12 at an appropriate temperature, preferably about 950°C.

25 In the form shown, the supply device includes a pipe 28 that extends into compartment 12 through top seal 18.

SUBSTITUTE SHEET (RULE 28)

Pipe 28 is connected to a gas reservoir 29 and supplies the gas from reservoir 29 to compartment 12, thereby creating an environment that inhibits passive oxidation of the contaminant.

5 The gas in reservoir 29 preferably is commercially pure argon, which has an oxygen concentration of less than 0.1 ppm. Argon provides a clean environment by preventing other impurities from getting onto the blank. Also, argon has a higher density than air and, therefore, will remain
10 in an uncovered compartment. Other gases can be used if they are benign, i.e., will not react with the blank, and provide an environment in the compartment that is substantially devoid of oxygen, i.e., an amount of oxygen small enough to substantially inhibit passive oxidation.
15 For example, commercially pure nitrogen, which has an oxygen concentration of approximately 80 ppm, could be selected.

 The gas in the compartment can be static or can flow through it. It is presently preferred to flow argon gas
20 through the compartment at a constant flow rate of 0.5 to 1.0 standard liters per minute (slpm). An appropriate flow rate can be chosen based on the particular gas selected.

 FIG. 2 shows a preferred drawing device for use with
25 the holding oven of the present invention. The preferred drawing device is a conventional zirconia muffle furnace

SUBSTITUTE SHEET (RULE 26)

30 that has been modified to provide an environment that causes active oxidation of a contaminant. This drawing device is described in the previously-mentioned U.S. Provisional Application No. 60/029,469. Other drawing
5 devices, such as a double crucible or a conventional graphite furnace, can be used if they provide an environment that causes active oxidation of a contaminant.

The furnace 30 shown in FIG. 2 includes a drawing portion 32 for heating blank 20 to a fiber drawing
10 temperature, which is typically about 2000°C. The drawing portion 32 has a refractory, oxide component, which in the disclosed embodiment is a zirconia muffle 34 that distributes heat generated by a heating coil 36. Insulation 38 surrounds a portion of muffle 34. The
15 integrity of the environment in the drawing portion has been improved by providing a high temperature ceramic glue (CERAMABOND #503, Armco Products) that forms a gas-tight seal between a beaker top 40 and an upper muffle extension 42, and a flat, closed-cell silicone gasket 44 (Material
20 No. 7204, Groendyk Mfg. Co.) that forms a gas-tight seal between a lower muffle extension 46 and an Elmer tube 48.

A blank support rod 50 holds blank 20 in drawing portion 32. An O-ring 52 forms a seal between a rod 50 and a sealing member 54, which is formed of metallic foil
25 or the like. Sealing member 54 connects to an end cap 56, which itself is connected to an annular member 58.

SUBSTITUTE SHEET (RULE 20)

The drawing device also has a supply device that supplies gas to the drawing portion to provide an environment in the drawing portion that causes active oxidation of the refractory contaminant and inhibits passive oxidation. As shown herein, the supply device includes a pipe 60, which extends through annular member 58. Pipe 60 is connected to a gas supply 62 and supplies gas from gas supply 62 to the drawing portion 32.

Pipe 60 preferably flows gas through muffle 34 at a constant flow rate of 2 to 5 slpm. The flow rate can be altered based on factors such as the flow rate needed to maintain control of fiber attributes.

The environment of drawing portion 32 preferably causes active oxidation of the contaminants by providing a low concentration of oxygen. The silicon carbide and silicon nitride contaminants corrode away due to active oxidation and are eliminated as break sources.

Preferably, the gas supply 62 supplies a purge gas containing a reducing gas that reacts with oxygen to lower the oxygen concentration of the environment of the drawing portion 32. More preferably, the purge gas consists of helium (He) and carbon monoxide (CO). The carbon monoxide is a reducing agent that reacts with oxygen to produce carbon dioxide (CO₂), thus reducing the oxygen concentration in the environment.

SUBSTITUTE SHEET (RULE 28)

When using the preferred purge gas, the gas supply 62 can be, for example, a reservoir of both helium and carbon monoxide or separate reservoirs of helium and carbon monoxide, the outputs of which are combined before or as they enter the draw furnace. In view of the toxic nature of carbon monoxide, however, it may be preferable to use an external furnace that produces carbon monoxide by reaction and, therefore, renders unnecessary a reservoir of carbon monoxide.

Fig. 2 diagrammatically illustrates such an external furnace 71. The external furnace 71 includes a reactive material 72 that reacts with at least a gas of a non-toxic gas mixture (provided by unillustrated gas reservoir(s)) to produce carbon monoxide. The reactive material 72 can be a porous carbon or graphite material (such as a carbon honeycomb substrate manufactured by Corning Incorporated, e.g., part no. K2225) through which the non-toxic gas mixture can be passed.

The non-toxic gas mixture preferably contains helium and a reactive gas. The reactive gas, which can be, for example, carbon dioxide or oxygen, will react with the carbon material 72 to produce carbon monoxide. The desired amount of carbon monoxide (preferably about 2% by volume) can be produced by manipulating the reactive gas concentration and the reaction temperature (the external furnace 71 preferably operates at atmospheric pressure).

SUBSTITUTE SHEET (RULE 28)

When the reactive gas is carbon dioxide, the equilibrium reaction is:

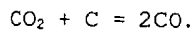

This reaction proceeds to near completion (more than 95% conversion) at 1000°C and atmospheric pressure.

When the reactive gas is oxygen, two competing reactions occur:

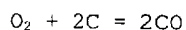
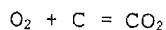

The reaction producing carbon monoxide is favored at high temperatures and low oxygen pressures. At 1000°C and atmospheric pressure ($P_{\text{O}_2} < 0.05$), thermodynamic equilibrium predicts that the CO:CO₂ ratio should be greater than 40:1. This ratio may be decreased if gas flow rates are fast enough to cause an incomplete reaction. However, the typical flow rate for a zirconia draw furnace (4.5 slpm) is slow enough to ensure that the reaction is not kinetically limited. This is true when either carbon dioxide or oxygen is the reactive gas.

Since the preferred non-toxic gas mixtures will have to be heated to produce the desired amount of carbon monoxide, the external furnace 71 will preferably include a heating device. The heating device can include a muffle 74 that distributes heat generated by a heating coil 76 to heat the gas to a preferred temperature of 1000°C. The muffle 74 may be made with alumina, but can be any

SUBSTITUTE SHEET (RULE 20)

material that will withstand relatively high temperatures and will not react with gas flowing through the external furnace 71.

Accordingly, the external furnace 71 can provide a
5 purge gas containing carbon monoxide without the risks inherent in maintaining a reservoir of carbon monoxide.

The purge gas preferably contains only as much carbon monoxide as is necessary to provide an oxygen
concentration that promotes active oxidation. The amount
10 of carbon monoxide required can be theoretically determined by, for example, calculating the amount of carbon monoxide required to cause P_{CO} (after introducing carbon monoxide) to be greater than P_{O_2} (before introducing carbon monoxide). Present zirconia muffle furnaces
15 require approximately 2 to 5% carbon monoxide in the purge gas to meet this requirement. Also, the necessary amount of carbon monoxide can be determined by measuring the oxygen concentration in the drawing portion and adjusting the amount of carbon monoxide until the appropriate oxygen
20 concentration is achieved. It is presently contemplated that a delta-F electrolyte detector can be used to measure the oxygen concentration in the drawing portion.

A conventional drawing mechanism (not shown) can be
used to draw a fiber from the blank in the environment in
25 the drawing portion.

SUBSTITUTE SHEET (RULE 26)

The second embodiment of a holding oven according to the present invention is shown in FIG. 6 and is designated generally by reference numeral 110. In this embodiment, gas flows through the holding oven 110 at a rate
5 sufficient to prevent an environmental contaminant, such as particulate zirconium compounds or calcium compounds, from becoming attached to the surface of the blank 20 and, preferably, to dislodge an environmental contaminant that was lodged on the surface of the blank 20 before
10 initiating the flow of gas.

The holding oven 110 includes a compartment 112 for storing the blank 20. The compartment 112 includes a muffle 114, which is gripped and supported by clamps 115. A top seal 18 and a cover 22 cover the top of the muffle
15 114, and a handle 24 extends through the cover 22 to hold the blank 20. Heaters and insulation 26 maintain the compartment 112 at an appropriate temperature.

The holding oven 110 also includes a supply device 162 that supplies gas to the compartment 112. The supply
20 device 162 preferably includes a nozzle device 163 having a rubber O-ring seal 166, a metal top ring 164, a rubber O-ring seal 167, a glass plate 168, a rubber O-ring seal 170, and a metal bottom ring 172. Bolts 174 urge the top and bottom rings 164 and 172 toward each other.

25 The supply device 162 also includes a pipe system 128 that supplies gas from a reservoir 129 to orifices 165

SUBSTITUTE SHEET (RULE 20)

disposed at spaced locations in the top ring 164 (FIG. 7). The gas in the reservoir 129 preferably is commercially pure nitrogen, although other benign gases such as argon can be used.

5 The gas supplied by the supply device 162 flows through the compartment 112, against a surface of the blank 20, and out of the compartment 112 through a gap 23 between the cover 22 and the handle 24. Preferably, the gas flows along the longitudinal direction of the blank
10 20, as shown by arrows in FIG. 6.

 The supply device 162 supplies the gas to the compartment 112 at a rate sufficient to prevent an environmental contaminant from becoming attached to the surface of the blank 20. The flowing gas forms a curtain
15 that substantially prevents environmental contaminants in the compartment 112 from contacting the surface of the blank 20. The gas should, of course, be free of environmental contaminants so it will not introduce such contaminants into the compartment 112.

20 In a more preferred mode, the supply device 162 supplies the gas to the compartment 112 at a rate sufficient to dislodge an environmental contaminant that was lodged on the surface of the blank 20 before
25 initiating the flow of gas. If the gas is flowed at a sufficient rate, the force of the gas will overcome the adhesion of the environmental contaminant to the blank

SUBSTITUTE SHEET (RULE 28)

(e.g., as by static charge) and dislodge the environmental contaminant from the surface of the blank 20. The gas will also prevent the environmental contaminant from resettling on the surface of the blank 20.

5 When the holding oven 110 is holding a silica-containing blank, flowing gas through the compartment 112 at a constant flow rate of 10 to 15 slpm should be sufficient to prevent most particulate contaminants from becoming attached to the surface of the blank 20 and
10 should also be sufficient to dislodge most particulate contaminants that may initially be lodged on the surface of the blank 20. However, a constant flow rate of 30 slpm is presently preferred because such a high flow rate will better ensure removal of environmental contaminants from
15 the surface of the blank 20. A particular flow rate for a specific environment can be readily determined by one of ordinary skill in the art.

 The following experiment illustrates an advantage of this embodiment. Fiber was drawn from blanks that had
20 been stored in a conventional holding oven (no purge gas) and in a holding oven according to the present invention (nitrogen flowing through the holding oven at a rate of 30 slpm). The average number of breaks per kilokilometer (kkm) in fiber drawn from the blanks that had been stored
25 in the conventional holding oven was more than twice the average number of breaks per kkm in fiber drawn from the

SUBSTITUTE SHEET (RULE 29)

blanks that had been stored in the holding oven of the present invention.

If an appropriate gas is chosen, not only can environmental contaminants be removed from the surface of the blank 20 and prevented from becoming attached to the surface, but the present embodiment can create an environment in the compartment 112 that inhibits passive oxidation of a refractory contaminant of the blank 20, such as silicon carbide or silicon nitride, in accordance with the principles described in connection with the first embodiment of the invention.

It will be apparent to those skilled in the art that various modifications and variations can be made in the method and apparatus of the present invention without departing from the scope or spirit of the invention. For example, although the preferred embodiments have been described with reference to the drawing of optical waveguide fibers from silica-containing blanks, certain aspects of the invention may be applied to the drawing of fibers of other suitable materials. As a further example, although the invention has been described with reference to silicon carbide and silicon nitride refractory contaminants, the invention may be used for other oxidizable, refractory contaminants, such as tungsten carbide. As yet another example, although the second embodiment of the invention has been described with

reference to environmental contaminants of particulate zirconia and calcium compounds, the invention may be used for other environmental contaminants.

5 Other embodiments of invention will be apparent to those skilled in the art from consideration of the specification and practice of the invention disclosed herein. It is intended that the specification and examples be considered as exemplary only, with a true scope and spirit of the invention being indicated by the
10 following claims.

THE CLAIMS DEFINING THE INVENTION ARE AS FOLLOWS:

1. A method for storing a blank having a refractory contaminant before use in a drawing device in which a fiber is to be drawn from the blank, including the steps of:
- 5 disposing the blank in a holding device; and
providing an environment in the holding device that inhibits passive oxidation of the contaminant.
- 10 2. The method of claim 1, wherein the contaminant includes a silicon compound.
3. The method of claim 2, wherein the silicon compound is at least one of silicon carbide and silicon nitride.
- 15 4. The method of any preceding claim, wherein the step of providing the environment includes providing a purge gas that contains a benign gas such that the environment is substantially devoid of oxygen.
- 20 5. The method of claim 4, wherein the benign gas is selected from the group consisting of argon and nitrogen.
6. The method of any preceding claim, wherein the blank contains silicon.
- 25 7. The method of any preceding claim, wherein the blank is a blank for drawing an optical waveguide fiber.
8. An apparatus adapted to store a blank having a refractory contaminant before use in a drawing device in which a fiber is to be drawn from the blank, including:
- 30 a compartment for storing the blank; and
a supply device that supplies gas to the compartment to provide an environment in the compartment that inhibits passive oxidation of the contaminant.



9. A method of producing a fiber from a blank having an oxidizable, refractory contaminant, including the steps of:
- storing the blank in a holding device having an environment that inhibits passive oxidation of the contaminant;
- 5 disposing the blank in a drawing portion of a drawing device having an environment that promotes active oxidation of the contaminant; and
- drawing a fiber from the blank in the drawing portion.
10. The method of claim 9, wherein the contaminant includes a silicon compound.
11. The method of claim 10, wherein the silicon compound is at least one of silicon carbide and silicon nitride.
- 15 12. The method of any one of claims 9 to 11, wherein the environment in the holding device includes a purge gas that contains a benign gas and that provides an environment in the holding device that is substantially devoid of oxygen.
- 20 13. The method of claim 12, wherein the benign gas is selected from the group consisting of argon and nitrogen.
14. The method of any one of claims 9 to 13, wherein the drawing device includes a furnace having a refractory, oxide component.
- 25 15. The method of claim 14, wherein the refractory, oxide component is a muffle including zirconia.
16. The method of any one of claims 9 to 15, wherein the environment in the drawing portion includes a purge gas containing a reducing gas that reacts with oxygen to lower oxygen concentration of the environment in the drawing portion.
- 30



17. The method of claim 16, wherein the reducing gas includes carbon monoxide.

18. The method of claim 16 or 17, wherein the purge gas includes helium and carbon monoxide.

19. The method of any one of claims 9 to 18, wherein the blank includes silicon.

20. The method of any one of claims 9 to 19, wherein the fiber is an optical waveguide fiber.

21. The method of any one of claims 9 to 20, wherein the drawing device includes a furnace having a zirconia muffle.

15
20
25
30

22. A system for producing fiber from a blank having an oxidizable, refractory contaminant, including:

- a compartment for storing the blank;
- a supply device that supplies gas to the compartment to provide an environment in the compartment that inhibits passive oxidation of the contaminant;
- a drawing portion for heating the blank to a fiber drawing temperature;

and
a supply device that supplies gas to the drawing portion to provide an environment in the drawing portion that causes active oxidation of the contaminant.

23. A method of producing a fiber from a member having an oxidizable, refractory contaminant, including the steps of:

- inhibiting passive oxidation of the contaminant;
- promoting active oxidation of the contaminant; and
- forming a fiber from the member in a forming portion of a forming device having a refractory oxide component in the forming portion.



24. The method of claim 23, wherein the contaminant includes a silicon compound.

25. The method of claim 24, wherein the silicon compound is at least one of
5 silicon carbide and silicon nitride.

26. The method of any one of claims 23 to 25, wherein the member includes silicon.

10 27. The method of any one of claims 23 to 26, wherein the fiber is an optical waveguide fiber.

28. A method of storing a blank before use in a drawing device in which a fiber is to be drawn from the blank, including the steps of:

15 disposing the blank in a holding device; and
flowing a gas against a surface of the blank in the holding device at a rate sufficient to prevent an environmental contaminant from becoming attached to the surface of the blank.

20 29. The method of claim 28, wherein the gas flow rate is sufficient to dislodge an environmental contaminant that was lodged on the surface of the blank before initiating the flow of gas.

25 30. The method of claim 28 or 29, wherein the gas flows along a longitudinal direction of the blank.

31. The method of any one of claims 28 to 30, wherein the step of flowing a gas provides an environment in the holding device that inhibits passive oxidation of a refractory contaminant of the blank.

30 32. The method of claim 31, wherein the gas provides an environment substantially devoid of oxygen.



33. The method of any one of claims 28 to 32, wherein the blank is a blank for drawing an optical waveguide fiber.

34. A method according to claim 1, substantially as herein described with reference to the accompanying drawings.

35. An apparatus according to claim 8, substantially as herein described with reference to the accompanying drawings.

36. A method according to claim 9, substantially as herein described with reference to the accompanying drawings.

37. A system according to claim 22, substantially as herein described with reference to the accompanying drawings.

38. A method according to claim 23, substantially as herein described with reference to the accompanying drawings.

39. A method according to claim 28, substantially as herein described with reference to the accompanying drawings.

DATED: 30 March 2001

PHILLIPS ORMONDE & FITZPATRICK

Patent Attorneys for:

CORNING INCORPORATED



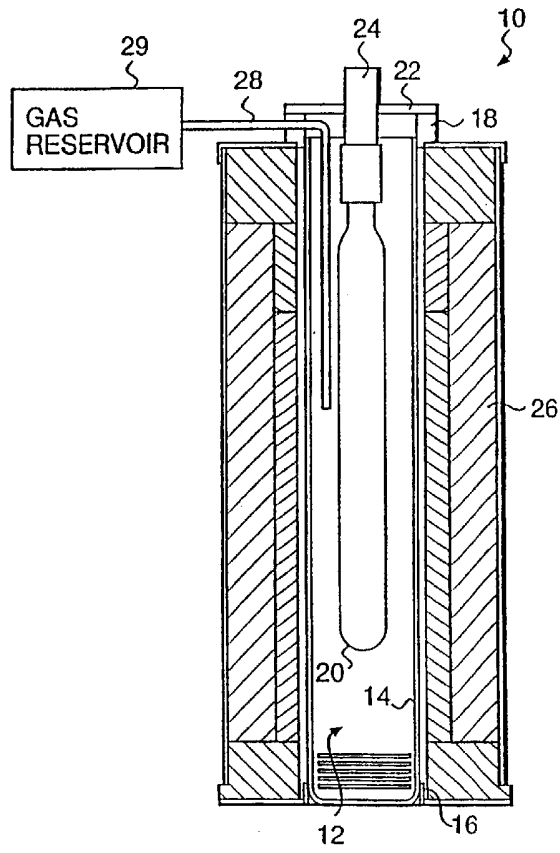
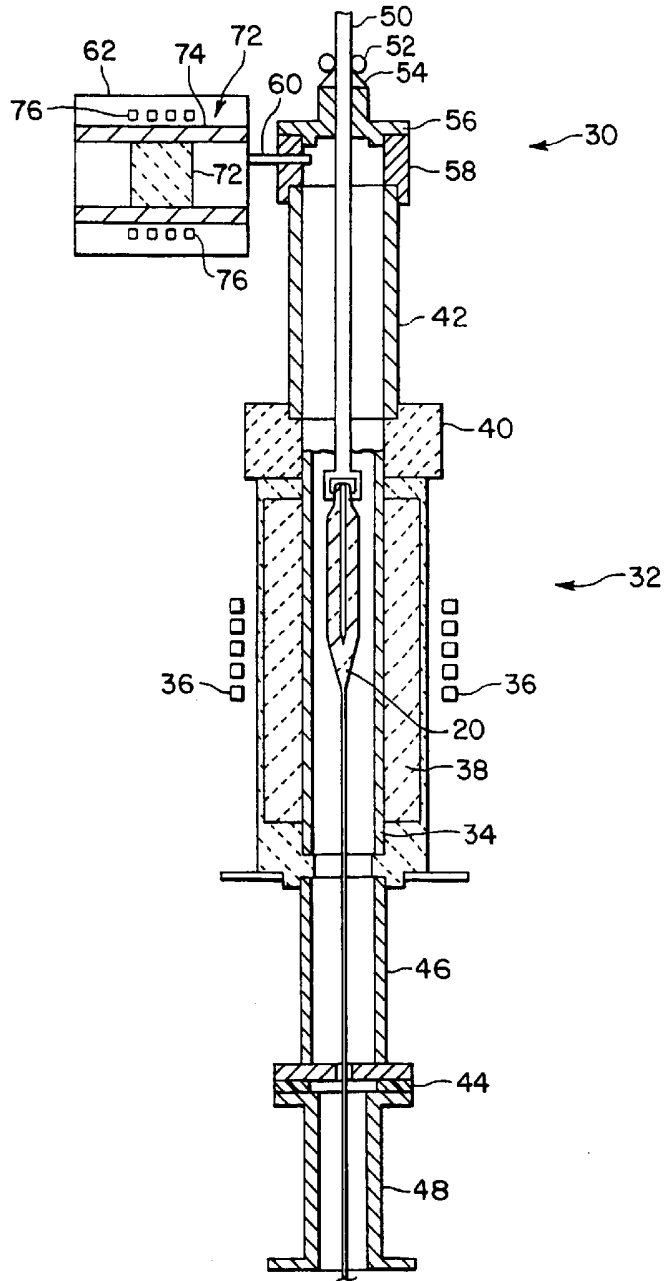

FIG. 1

SUBSTITUTE SHEET (RULE 26)

FIG. 2



SUBSTITUTE SHEET (RULE 28)

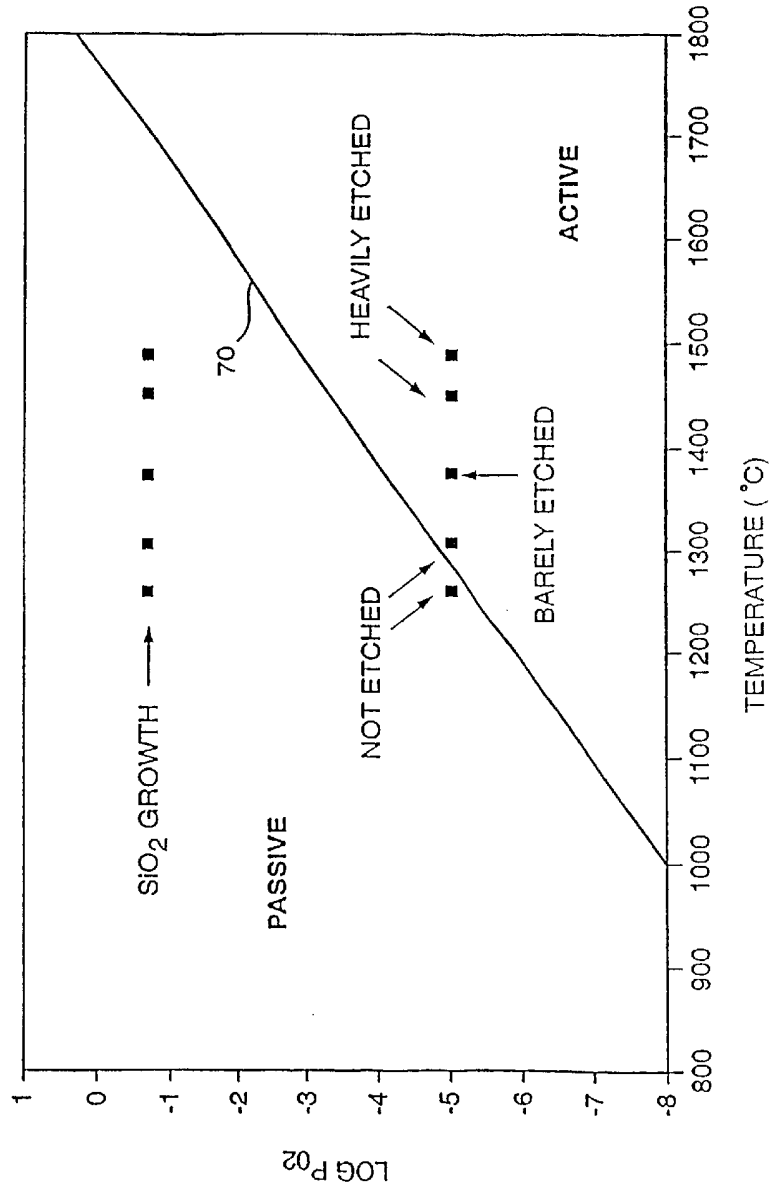

FIG. 3

SUBSTITUTE SHEET (RULE 26)

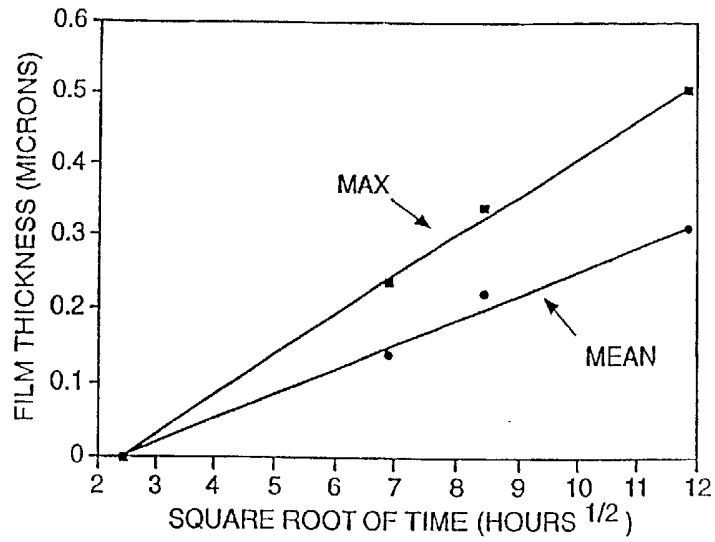

FIG. 4

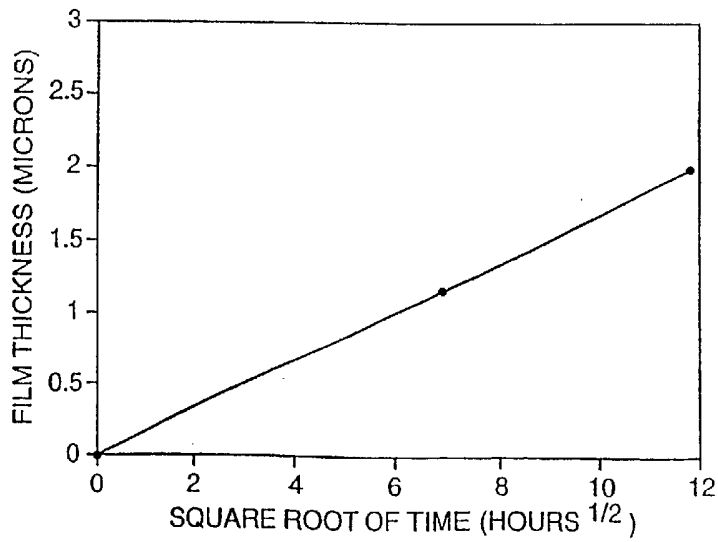
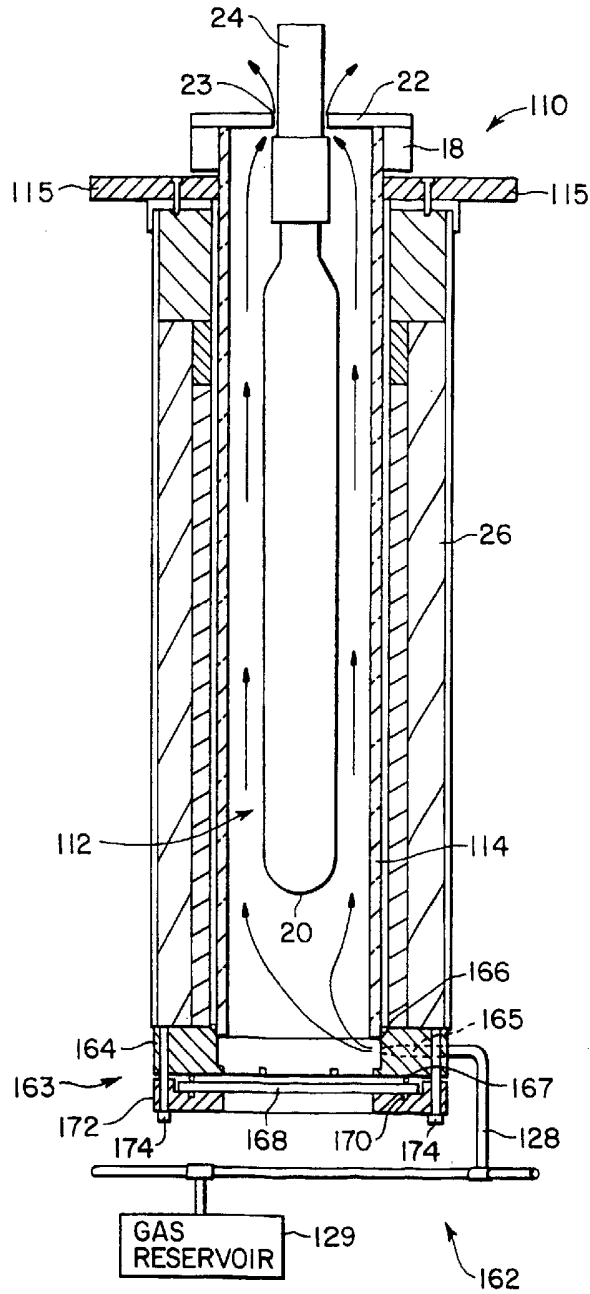

FIG. 5

5/6

FIG. 6



SUBSTITUTE SHEET (RULE 20)

FIG. 7

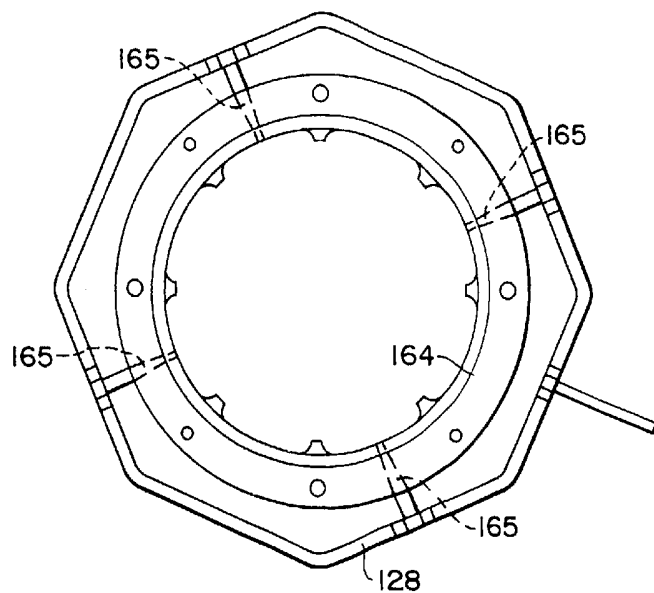

SUBSTITUTE SHEET (RULE 26)