



(72) YORKEY, THOMAS J., US

(72) MANNHEIMER, PAUL D., US

(71) NELLCOR PURITAN BENNETT INCORPORATED, US

(71) MALLINCKRODT INC., US

(71) HUTCHINSON, GLENN, GB

(51) Int.Cl.<sup>6</sup> A61B 5/00

(30) 1998/05/26 (09/085,475) US

(54) **PROCEDE ET SYSTEME POUR ESTIMER UN PARAMETRE  
PHYSIOLOGIQUE AU MOYEN DE TRANSFORMEES**

(54) **METHODS AND APPARATUS FOR ESTIMATING A  
PHYSIOLOGICAL PARAMETER USING TRANSFORMS**

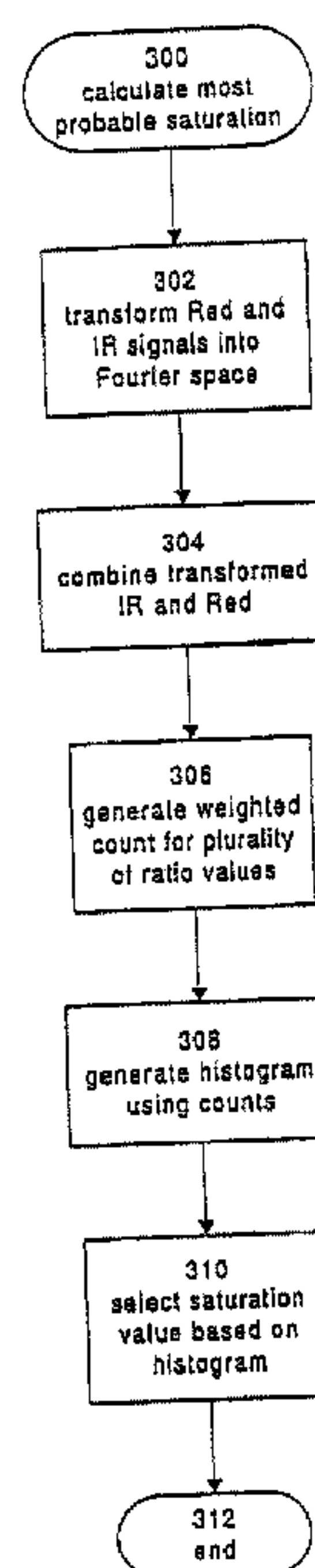

(57) A method for use in a system for determining a physiological parameter is described. The system has a sensor for transmitting electromagnetic energy of first and second wavelengths toward a tissue sample and detecting the electromagnetic energy after scattering of the electromagnetic energy by the tissue sample, thereby generating a first signal corresponding to the first wavelength and a second signal corresponding to the second wavelength. The first and second signals are transformed into the frequency domain, thereby generating third and fourth signals. A ratio signal is generated using the third and fourth signals. For each of a plurality of ratio values an associated sum is generated corresponding to the number of times the ratio signal coincides with the ratio value associated with the sum. Contributions to each sum are weighted in accordance with the third signal. A best ratio value is selected from the plurality of ratio values based on the sums associated therewith.



PCT

WORLD INTELLECTUAL PROPERTY ORGANIZATION  
International Bureau

## INTERNATIONAL APPLICATION PUBLISHED UNDER THE PATENT COOPERATION TREATY (PCT)

(51) International Patent Classification <sup>6</sup> : <b>A61B 5/00</b>	<b>A1</b>	(11) International Publication Number: <b>WO 99/60918</b> (43) International Publication Date: 2 December 1999 (02.12.99)
<p>(21) International Application Number: PCT/GB99/01451</p> <p>(22) International Filing Date: 26 May 1999 (26.05.99)</p> <p>(30) Priority Data: 09/085,475                      26 May 1998 (26.05.98)                      US</p> <p>(71) Applicants: NELLCOR PURITAN BENNETT INCORPORATED [US/US]; 4280 Hacienda Drive, Pleasanton, CA 94588 (US). MALLINCKRODT INC. [US/US]; 4280 Hacienda Drive, Pleasanton, CA 94588 (US). HUTCHINSON, Glenn [GB/GB]; 1 Glen Villas, Fidlers Well, Bamford, Derbyshire S33 0AR (GB).</p> <p>(72) Inventors: YORKEY, Thomas, J.; Mallinckrodt Inc., 4280 Hacienda Drive, Pleasanton, CA 94588 (US). MANNHEIMER, Paul, D.; Mallinckrodt Inc., 4280 Hacienda Drive, Pleasanton, CA 94588 (US).</p> <p>(74) Agent: HUTCHINSON, Glenn; Dibb Lupton Alsop, Fountain Precinct, Balm Green, Sheffield S1 1RZ (GB).</p>	<p>(81) Designated States: AU, CA, JP, European patent (AT, BE, CH, CY, DE, DK, ES, FI, FR, GB, GR, IE, IT, LU, MC, NL, PT, SE).</p> <p><b>Published</b> <i>With international search report.</i></p>	
(54) Title: METHODS AND APPARATUS FOR ESTIMATING A PHYSIOLOGICAL PARAMETER USING TRANSFORMS		
(57) Abstract		
<p>A method for use in a system for determining a physiological parameter is described. The system has a sensor for transmitting electromagnetic energy of first and second wavelengths toward a tissue sample and detecting the electromagnetic energy after scattering of the electromagnetic energy by the tissue sample, thereby generating a first signal corresponding to the first wavelength and a second signal corresponding to the second wavelength. The first and second signals are transformed into the frequency domain, thereby generating third and fourth signals. A ratio signal is generated using the third and fourth signals. For each of a plurality of ratio values an associated sum is generated corresponding to the number of times the ratio signal coincides with the ratio value associated with the sum. Contributions to each sum are weighted in accordance with the third signal. A best ratio value is selected from the plurality of ratio values based on the sums associated therewith.</p>	<pre> graph TD     300([300 calculate most probable saturation]) --&gt; 302[302 transform Red and IR signals into Fourier space]     302 --&gt; 304[304 combine transformed IR and Red]     304 --&gt; 306[306 generate weighted count for plurality of ratio values]     306 --&gt; 308[308 generate histogram using counts]     308 --&gt; 310[310 select saturation value based on histogram]     310 --&gt; 312([312 end])   </pre>	

5                                   **METHODS AND APPARATUS FOR ESTIMATING A  
PHYSIOLOGICAL PARAMETER USING TRANSFORMS**

**BACKGROUND OF THE INVENTION**

10       The present invention relates to methods and apparatus  
for estimating a physiological parameter using, for example,  
Fourier transforms. More specifically, the invention relates  
to a pulse oximetry system for estimating the oxygen  
saturation of haemoglobin in arterial blood in which a  
saturation value is determined from representations of the  
oximeter sensor signals in a transformed space.

15       Pulse oximeters measure and display various blood flow  
characteristics and blood constituents including but not  
limited to the oxygen saturation of haemoglobin in arterial  
blood. An oximeter sensor passes light through blood-perfused  
tissue and photoelectrically senses the absorption of the  
20   light by the tissue. The light passed through the tissue is  
selected to be of one or more wavelengths that are absorbed by  
the blood in an amount representative of the amount of the  
blood constituent being measured. The amount of light  
absorbed is then used to calculate the amount of the blood  
25   constituent present in the blood.

      The sensed light signals can be degraded by both noise  
and motion artifact. One source of noise is ambient light  
that reaches the sensor's light detector. Another source of  
noise is electromagnetic coupling from other electronic  
30   instruments. Motion of the patient also introduces noise and  
affects the detected light energy. For example, the contact  
between the sensor's detector and/or emitter and the tissue  
sample can be temporarily disrupted when motion causes either  
to move away from the tissue. In addition, because blood is  
35   fluid, it responds differently than the surrounding tissue to  
inertial effects, thus resulting in momentary changes in

volume at the point to which the oximeter sensor is attached. The degradation of the detected light energy can, in turn, result in degradation of the pulse oximeter output and inaccurate reporting of the blood constituent concentration.

5 It will be understood that such inaccuracies can have negative consequences.

A variety of techniques have been developed to minimise the effects of noise and motion artifact in pulse oximetry systems. In a system described in US Patent No 5,025,791, an  
10 accelerometer is used in the oximetry sensor to detect motion. When motion is detected, data taken during the motion are either eliminated or indicated as being corrupted. In US Patent No 4,802,486, assigned to Nellcor Puritan Bennett, the assignee of the present invention, the entire disclosure of  
15 which is incorporated herein by reference, an EKG signal is monitored and correlated to the oximeter reading to provide synchronisation to limit the effect of noise and motion artifact pulses on the oximeter readings. This reduces the chance of the oximeter locking onto a motion signal. In US  
20 Patent No 5,078,136, assigned to Nellcor Puritan Bennett, the assignee of the present invention, the entire disclosure of which is incorporated herein by reference, signal processing techniques such as linear interpolation and rate of change analysis are employed to limit the effects of noise and motion  
25 artifact.

In another oximetry system described in US Patent No 5,490,505, an adaptive noise canceller is used on different additive combinations of the red and infrared signals from the oximeter sensor to identify a coefficient for which the output  
30 of the noise canceller best represents the oxygen saturation of haemoglobin in the patient's blood. Unfortunately, this technique is computationally intensive resulting in an expensive implementation with undesirably high power requirements.

35 In yet another oximetry apparatus in US Patent No 5,632,272, a technique using a Fourier transform is described.

26-07-2000

GB 009901451

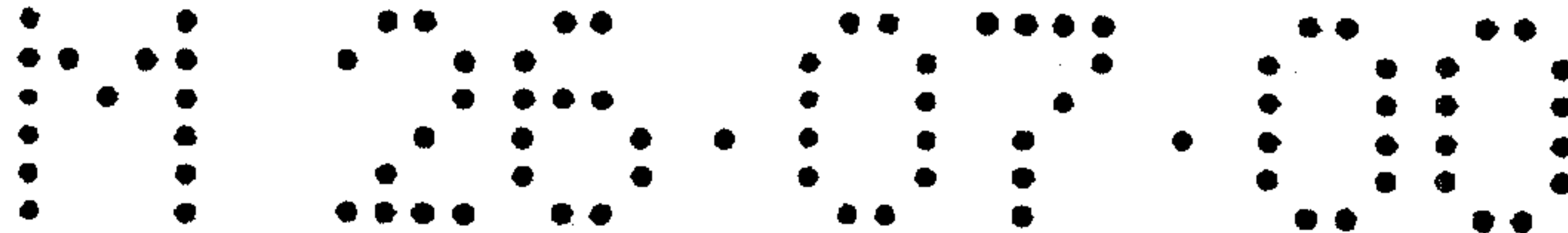

3

Data from the Fourier transform is analysed to determine the arterial blood saturation, by considering all Fourier energies above a threshold with equal importance. However, the technique described in the 5,632,272 patent is inadequate in the presence of significant random motion, where many anomalous signals exist above the noise threshold.

Because each of the above-described techniques has its own limitations and drawbacks, it is desirable to develop techniques for processing the signals from oximetry sensors to more accurately determine blood-oxygen levels in the presence of noise and motion artifact.

According, a first aspect of the present invention provides a method for determining a physiological parameter, the method comprising the steps of

receiving first and second signals from a sensor for detecting electromagnetic energy of first and second wavelengths;

generating a ratio signal comprising ratio values using a transformation of the first and second signals;

calculating, for a plurality of ratio values, respective sums using variable weighting data derived from the transformation of the first signal, the variable weighting data including non integer values; and

selecting one of the plurality of ratio values using the respective sums as being representative of the physiological parameter.

According to the present invention, a method and apparatus are provided by which noise from motion artifact and a variety of other sources is effectively removed from oximetry sensor signals for a reliable determination of the oxygen saturation of haemoglobin in a patient's arterial blood. Processed representations of the Red and IR signals from an oximetry sensor are combined in Fourier space and compared to a plurality of different values each of which corresponds to a different saturation value. A weighted

26-07-2000

GB 009901451

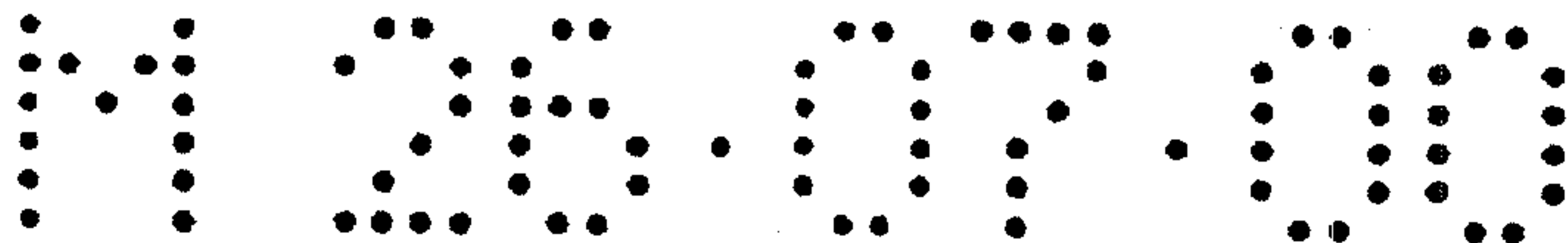

3a

count, also referred to herein as a sum, is maintained for each of the values which reflects the number of times the combined signal passes through the particular value. This information is used to generate a histogram or "saturation transform" of possible saturation values. The weights applied to contributions to each of the sums are selected in accordance with a representation of the IR signal in Fourier space. That is, individual contributions to each count are weighted according to the IR power level at the corresponding frequency.

The histogram typically includes a number of local maxima, only one of which corresponds to the arterial blood saturation value. According to various embodiments, selection of the appropriate maximum may be accomplished using any of a

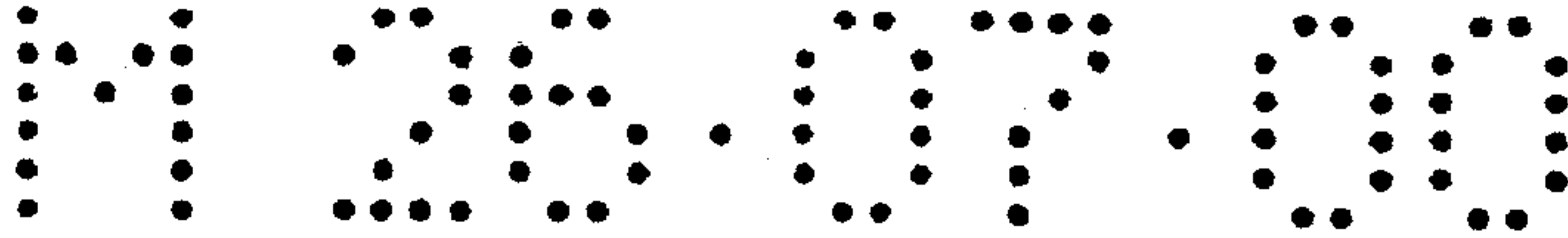

4

variety of peak selection algorithms. For example, according to one embodiment, the local maximum corresponding to the highest weighted count is selected. According to another embodiment, the local maximum corresponding to the highest saturation value is selected. According to yet another embodiment, the local maximum corresponding to a saturation value that is closes to the most recent motion-free saturation value is selected.

Thus, an embodiment of the present invention provides a method for use in a system for determining a physiological parameter. The system has a sensor for transmitting electromagnetic energy of first and second wavelengths toward a tissue sample and detecting the electromagnetic energy after scattering of the electromagnetic energy by the tissue sample, thereby generating a first signal corresponding to the first wavelength and a second signal corresponding to the second wavelength. The first and second signals are transformed into the frequency domain, thereby generating third and fourth signals. A ratio signal is generated using the third and fourth signals. For each of a plurality of ratio values an associated sum is generated corresponding to the number of times the ratio signal coincides with the ratio value associated with the sum. Contributions to each sum are weighted in according with the third signal. A best ratio value is selected from the plurality of ratio values based on the sums associated therewith.

A further understanding of the nature and advantages of the present invention may be realised by reference to the remaining portions of the specification and the drawings.

30

#### BRIEF DESCRIPTION OF THE DRAWINGS

Fig 1 is a block diagram of a pulse oximetry system for use with the present invention;

Fig 2 is a flowchart illustrating the operation of the pulse oximetry system of Fig 1;

Fig 3 is a flowchart illustrating the calculation of the oxygen saturation of haemoglobin in arterial blood according to a specific embodiment of the invention; and

5 Figs 4a-4c are graphs showing representations of various signals used in the saturation calculation algorithm of the present invention.

#### DESCRIPTION OF SPECIFIC EMBODIMENTS

Fig 1 is a block diagram of an oximetry system 100 for use with the present invention. An oximetry sensor 102 is  
10 attached to, for example, a patient's finger 104. Red and infrared (IR) LEDs 106 and 108 alternately transmit Red and IR light toward finger 104. Detector 110 receives the Red and IR light transmitted through finger 104. Sensor 102 is connected to oximeter 112 which receives and processes the signal from  
15 detector 110, and which also provides the drive signal to LEDs 106 and 108. The detector signal is received by front end signal processing circuitry 114 which demodulates the alternately transmitted Red and IR light received by detector 110, cancels ambient light, and includes fixed and variable  
20 hardware gain stages prior to digitisation.

The processed analog signal is converted to a digital signal by analog-to-digital conversion circuitry 116 and sent to central processing unit (CPU) 118 for computation of estimates of the oxygen saturation of haemoglobin in the  
25 patient's arterial blood according to a specific embodiment of the invention. The calculated saturation is then sent to display 120. CPU 118 also controls LED drive circuitry 122 which provides the drive signals for LEDs 106 and 108, and the demodulation of the collected light signals in front end  
30 circuitry 114. One example of an oximetry system for use with the present invention is described in commonly assigned, copending US Application Serial No 08/660,510 for METHOD AND APPARATUS FOR ESTIMATING PHYSIOLOGICAL PARAMETERS USING MODEL-BASED ADAPTIVE FILTERING filed on June 7, 1996, which was  
35 based on Provisional Application No 60/000,195 filed on June



14, 1995, the entire specifications of which are incorporated herein by reference.

Fig 2 is a flowchart 200 illustrating the operation of the pulse oximetry system of Fig 1. Data acquisition (step 202) may be achieved using a wide variety of available sensor and front-end analog signal processing such as, for example, sensor 102 and circuitry 114 of Fig 1. The acquired data are digitised at an appropriate sample rate (step 204), and the natural logarithm of the digitised Red and IR waveforms is taken (step 206). The resulting data are then bandpass filtered (step 208) with an infinite impulse response filter (IIR) having a high pass cutoff at 0.5 Hz and a low pass roll off from 10 to 20 Hz.

The signals are then employed for calculation of the pulse rate and saturation (steps 212 and 214). The values yielded by these process steps are both subjected to post processing (steps 216 and 218) which uses available metrics with regard to the calculated values to determine their reliability and whether and how they should be displayed. The respective values are then displayed (steps 220 and 222). A portion of saturation algorithm 214 will now be described in greater detail with reference to Fig 3.

Fig 3 is a flowchart 300 illustrating the calculation of the oxygen saturation of haemoglobin in arterial blood according to a specific embodiment of the invention. Figs 4a-4c show representations of various signals used in the saturation calculation algorithm of the present invention. It will be understood that the described embodiment may be used in conjunction with a plurality of other methods for calculating saturation to thereby provide several independently calculated values from which the best value may then be selected. According to a specific embodiment, the processed and digitised Red and IR signals are transformed into Fourier Space (step 302). This Fourier transform results in frequency samples  $f_i$ . The Fourier transformed signals are denoted by  $IR(f_i)$  and  $Red(f_i)$ , which are both complex numbers.

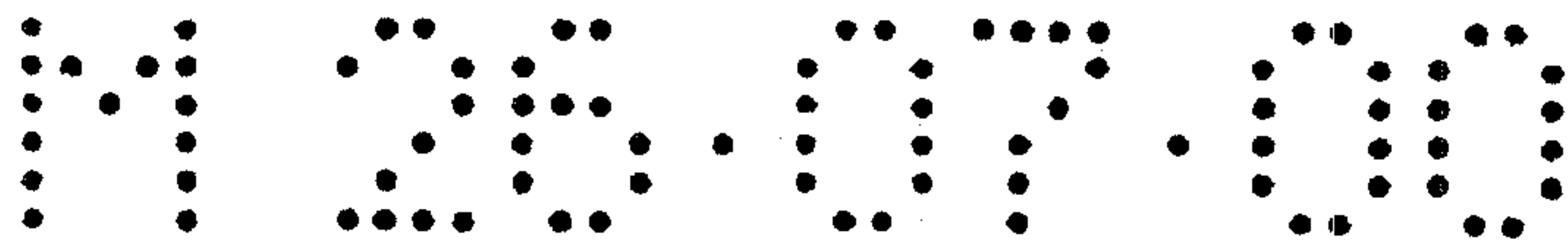

7

The relative magnitudes of some representative Fourier transformed signals are shown in Fig 4a.

Both the Red and IR waveforms (402 and 404 respectively) have components at the heart rate (approximately 1 Hz) and multiples thereof. The IR signal is then combined with the Red signal (step 304) generating a ratio signal 406 (Fig 4b) given by,

$$\omega_i = \frac{\text{Re}\{IR(f_i)^* \times Red(f_i)\}}{IR(f_i)^* \times IR(f_i)}$$

Where \* denotes a complex conjugate, and Re{x} connotes the real part of {x}.

As shown in Fig 4b, ratio signal 406 is relatively stable in the frequency ranges around each multiple of the heart rate and apparently random outside of these ranges.

A weighted count or sum,  $h(\omega)$ , is then generated (step 306) for each of a plurality of ratio values,  $\omega_i$ . The counts represent the strength of the IR amplitude at frequency indices  $(f_i)$ , where the ratio value  $\omega_i$  equals the particular ratio value,  $\omega$ . That is

$$\frac{h(\omega) = \sum |IR(f_i)|}{\forall i.t. \omega_i = \omega}$$

Where the sum is for all  $i$  such that  $\omega_i = \omega$ .

The counts may be real numbers that correspond to the resolution of the measurement  $|IR(f_i)|$ , or may be integer or quantised approximations. In a specific embodiment, more than two possible values of the counts/weights are used. A histogram is generated (step 308) using the counts for each  $\omega_i$ . An example of the histogram  $h(\omega)$  is shown in Fig 4c. According to a specific embodiment, the range of  $\omega_i$  values is as follows:

$$0.4 < \omega_i < 2.5; \Delta \omega_i = 0.05$$

Each contribution to the count for a particular  $\omega_i$  is weighted according to the strength of the IR signal at that Fourier index. That is, the weights accorded to each transition of the ratio signal (Fig 4b) through a particular ratio value  $\omega_i$  are determined with reference to the amplitude of the IR signal as shown in Fig 4a. Thus, the transitions that occur at or near the peaks (in Fourier space) of the IR waveform are weighted significantly more than those that occur where the IR amplitude is low. During motion, this typically results in a histogram having local maxima at two or more different values of  $\omega_i$ , only one of which corresponds to the actual saturation value.

If multiple peaks occur in the histogram, selection of the appropriate  $\omega_i$  peak that corresponds to the arterial oxygen saturation for display (step 310) may be accomplished using a "peak selection" algorithm. Such an algorithm may be configured in a variety of ways including, but not limited to

- 1) The peak with the largest weighted count may be selected;
- 2) The peak corresponding to the highest saturation value may be selected;
- 3) The peak corresponding to a saturation value that is closest to the most recent saturation value calculated prior to the onset of motion may be selected. According to one embodiment, determination of the presence of motion is accomplished with a "motion detection" algorithm such as disclosed in US Patent No 5,662,106 for OXIMETER WITH MOTION DETECTION FOR ALARM MODIFICATION issued on September 2, 1997, the entire specification of which is incorporated herein by reference for all purposes;
- 4) The peak corresponding to a saturation value closest to a predicted saturation value may be selected, where the

predicted saturation value comes from following the trend of recently displayed saturations. According to various embodiments, this trend may, for example, incorporate the recently displayed saturation value, the time rate of change of recently displayed saturation values (ie saturation "velocity"), and the time rate of change of the change in recently displayed saturation values (ie saturation "acceleration") according to the following formula:

$$\text{predicted saturation} = \text{last displayed saturation} + C_v (dS/dt) + C_a (d^2S/dt^2),$$

where  $C_v$ =velocity constant

$C_a$ =acceleration constant

$dS/dt$  = time rate of change of recent previously displayed saturations

$d^2S/dt^2$  = time rate of change of recent values of  $dS/dt$ ;

5) The peak corresponding to the higher of two tracking saturations may be selected, where the trend (as described above) of each of the peaks present in the histogram is conducted and those which track one another may be associated with the venous and arterial blood oxygen saturations. That is, a pure "motion" peak often is created and is unchanging near  $\omega_i = 1$ , while peaks that arise due to movement of venous and arterial blood will track one another, and in particular will track one another during a changing saturation condition. The  $\omega_i$  peak corresponding to the higher saturation of the two "tracking" peaks is associated with the arterial oxygen saturation;

6) An algorithm that arbitrates between a subset of the algorithms listed above may be used, where arbitration is accomplished by choosing the most appropriate method to

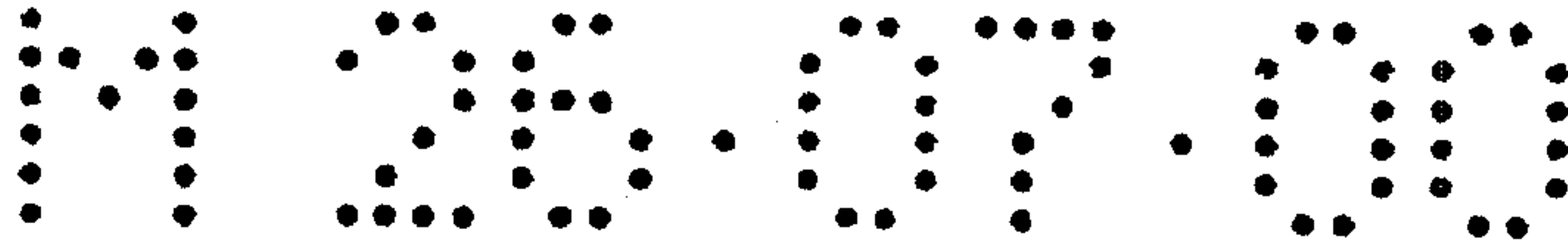

10

5 use based on various signal factors. Such signal factors may include, but are not limited to, the number of local maxima in the histogram, the absence or presence of motion, or the degree of motion. For example, according to a specific embodiment, in the absence of motion, method #2 is used. According to another embodiment, method #3 is used in the presence of motion. In another specific embodiment, the arbitrating algorithm is configured such that in the absence of motion and/or when  
10 two  $\omega_i$  peaks are present, method #2 is used. However, if three or more peaks are present, method #5 is used.

Those skilled in the art will recognise that other schemes for selecting the  $\omega_i$  peak corresponding to arterial saturation for display may be employed without departing from  
15 the scope of the invention.

While the invention has been particularly shown and described with reference to specific embodiments thereof, it will be understood by those skilled in the art that changes in the form and details of the disclosed embodiments may be made  
20 without departing from the spirit or scope of the invention. For example, signal transforms other than the Fourier transform may be employed. Other such transforms include the Wavelet Transform, the Cosine Transform, a Bessel transform and the Legendre Polynomial Transform. Furthermore, more than  
25 two wavelengths of light could be utilised, such as described in commonly assigned US Patent No 5,645,060 entitled METHOD AND APPARATUS FOR REMOVING ARTIFACT AND NOISE FROM PULSE OXIMETRY issued on July 8, 1997, the entire specification of which is incorporated herein by reference for all purposes, or  
30 in the utilisation of multivariate analysis in which many wavelengths are considered. Therefore, the scope of the invention should be determined with reference to the appended claims.

26-07-2000

Claims amended July 6, 2000

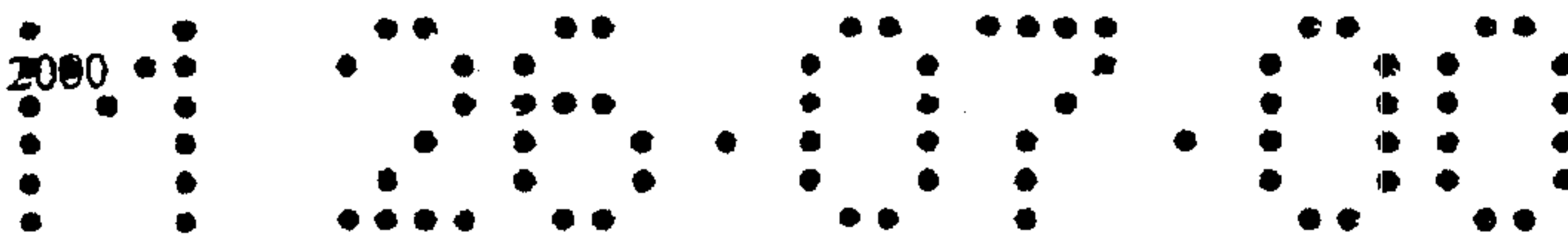

## CLAIMS

1. A method for determining a physiological parameter, the method comprising the steps of
  - receiving first and second signals from a sensor for detecting electromagnetic energy of first and second wavelengths;
  - generating a ratio signal comprising ratio values using a transformation of the first and second signals;
  - calculating, for a plurality of ratio values, respective sums using variable weighting data derived from the transformation of the first signal, the variable weighting data including non integer values; and
  - selecting one of the plurality of ratio values using the respective sums as being representative of the physiological parameter.
2. A method as claimed in claim 1, wherein the data comprises at least three different values including the integer 1 and fractions thereof.
3. A method as claimed in any preceding claim, wherein the step of selecting one of the plurality of ratio values using the respective sums comprises the step of
  - using a first peak selection algorithm to select said one of the plurality of ratio values.
4. A method as claimed in claim 3, wherein the first peak selection is one of a plurality of peak selection algorithms, the method further comprises the step of
  - selecting the first peak selection algorithm from the plurality of peak selection algorithms based on at least one factor associated with the plurality of ratio values.
5. A method as claimed in any preceding claim, wherein the data for the respective sums are derived from and are proportional

26-07-2000

Claims amended July 6, 2000



to a magnitude of the first signal.

6. A method as claimed in claim 5, wherein the data have values that are proportional to the magnitude of the transformation of the first signal.
7. A method as claimed in any preceding claim, wherein the physiological parameter comprises blood oxygen saturation of haemoglobin in arterial blood, and each of the plurality of ratio values corresponds to a particular saturation value.
8. A method as claimed in any preceding claims, further comprising the step of transforming, using a selectable transformation, the first and second signals to produce the transformation of the first and second signals, wherein the selectable transformation is at least one of a Fourier transformation, Laplace transform, a Wavelet transform, a Cosine transform, a Bessel transformation, or a Legendré polynomial transformation transform.
9. A method as claimed in any preceding claim, further comprising the step of calculating an estimate of a heart rate from the transformation of the first and second signals.
10. An apparatus for determining a physiological parameter, the apparatus comprising
  - a receiver for receiving first and second signals derived from a sensor for detecting electromagnetic energy of first and second wavelengths;
  - a signal processor for generating a ratio signal comprising ratio values using transformations of the first and second signals, and calculating, for a plurality of ratio values, respective sums using variable weighting data derived from the transformations of the first signal, the variable weighting data including non integer values; and a selector for selecting one of the plurality of ratio values using the

26-07-2000

Claims amended July 6, 2000

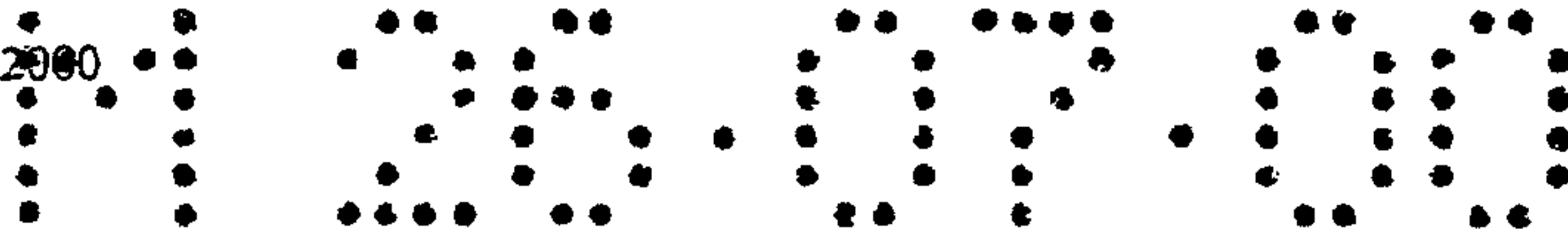

respective sums as being representative of the physiological parameter.

11. An apparatus as claimed in claim 10, wherein the data comprises at least three different values including the integer 1 and fractions thereof.
12. An apparatus as claimed in either of claims 10 and 11, wherein selector for selecting one of the plurality of ratio values using the respective sums uses a first peak selection algorithm to select said one of the plurality of ratio values.
13. An apparatus as claimed in claim 12, wherein the first peak selection is one of a plurality of peak selection algorithms, the selector further comprises means to select the first peak selection algorithm from the plurality of peak selection algorithms based on at least one factor associated with the plurality of ratio values.
14. An apparatus as claimed in any of claims 10 to 13, wherein the data for the respective sums are derived from and are proportional to a magnitude of the first signal.
15. An apparatus as claimed in claim 14, wherein the data have values that are proportional to the magnitude of the transformation of the first signal.
16. An apparatus as claimed in any of claims 10 to 15, wherein the physiological parameter comprises blood oxygen saturation of haemoglobin in arterial blood, and each of the plurality of ratio values corresponds to a particular saturation value.
17. An apparatus as claimed in any of claims 10 to 16, further comprising a transformer for transforming, using a selectable transformation, the first and second signals to produce the transformation of the first and second signals, wherein the



26-07-2000

GB 009901451

Claims amended July 6, 2000

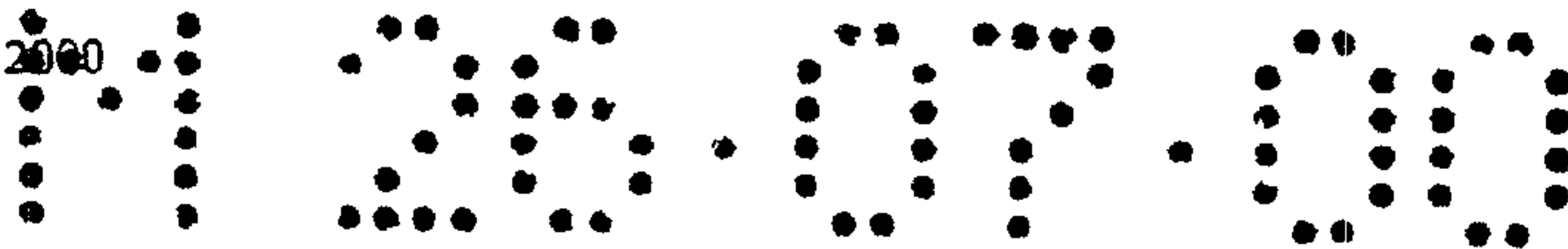

selectable transformation is at least one of a Fourier transformation, Laplace transform, a Wavelet transform, a Cosine transform, a Bessel transformation, or a Legendré polynomial transformation transform.

18. An apparatus as claimed in any of claims 10 to 17, further comprising a calculator to calculate an estimate of a heart rate from the transformation of the first and second signals.

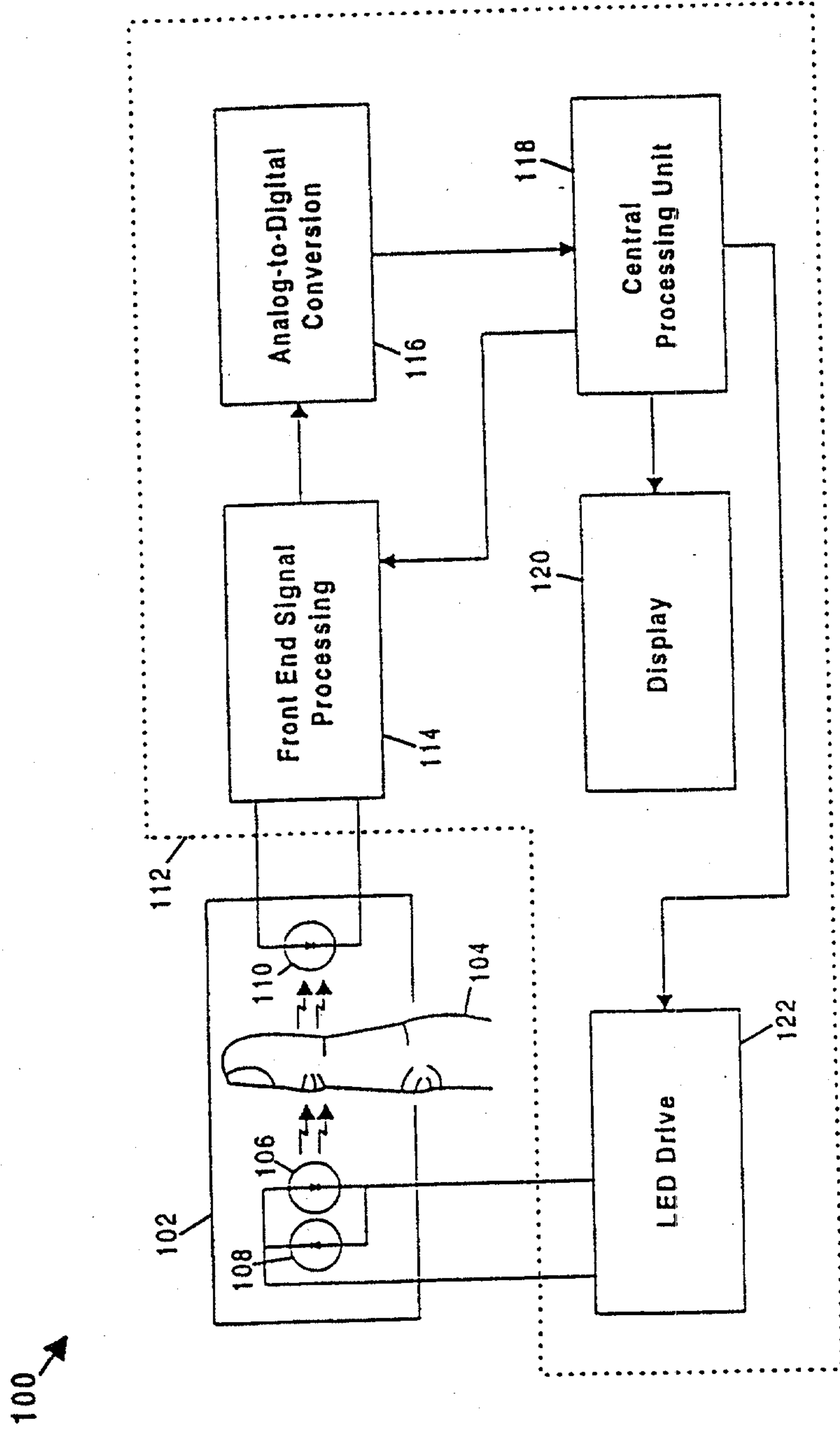

Fig. 1

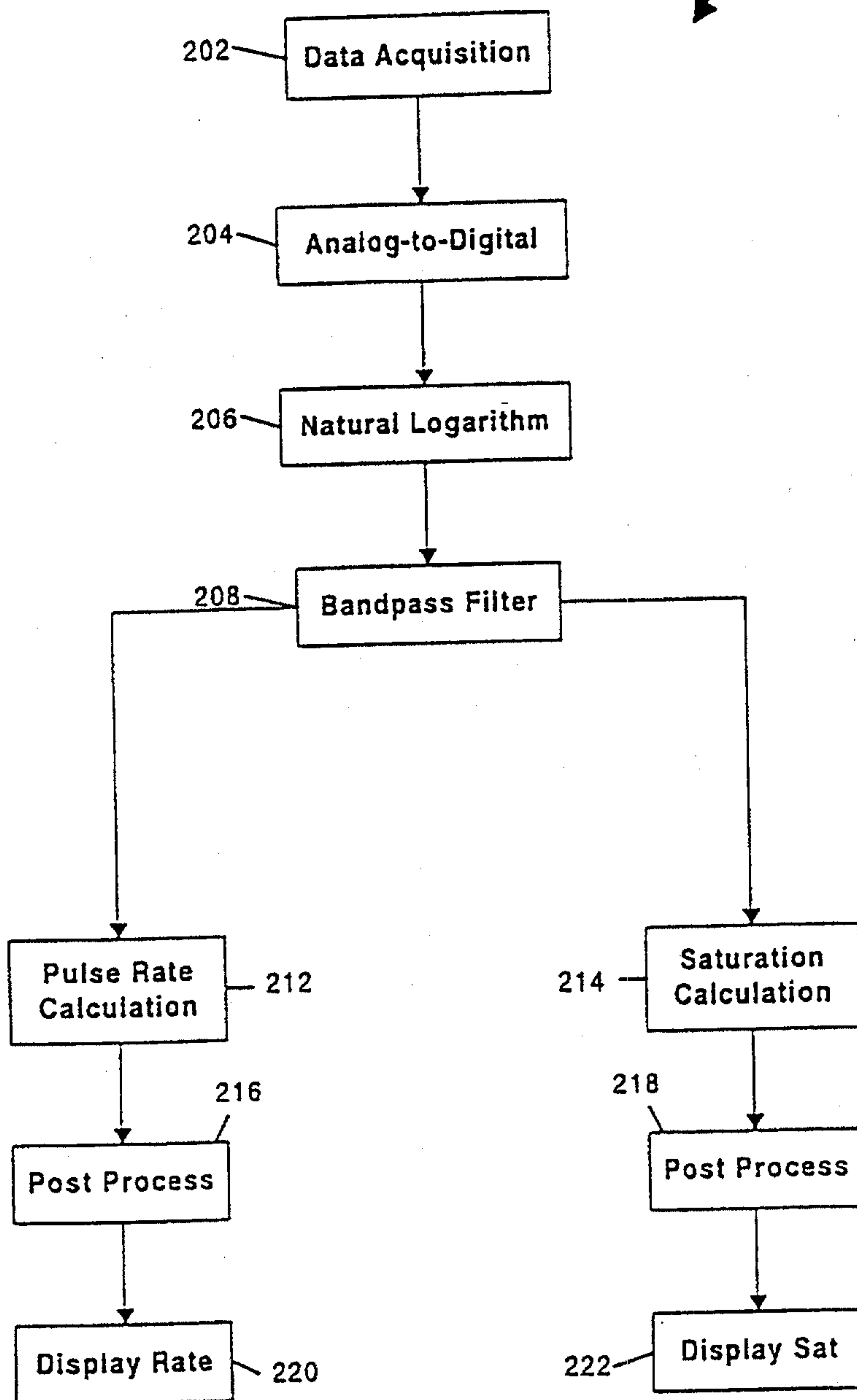

Fig. 2

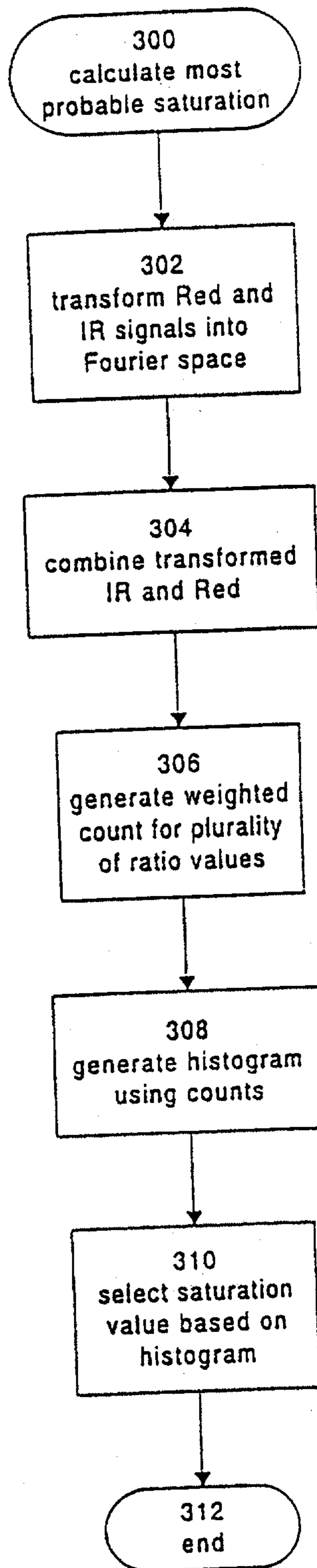

Fig. 3

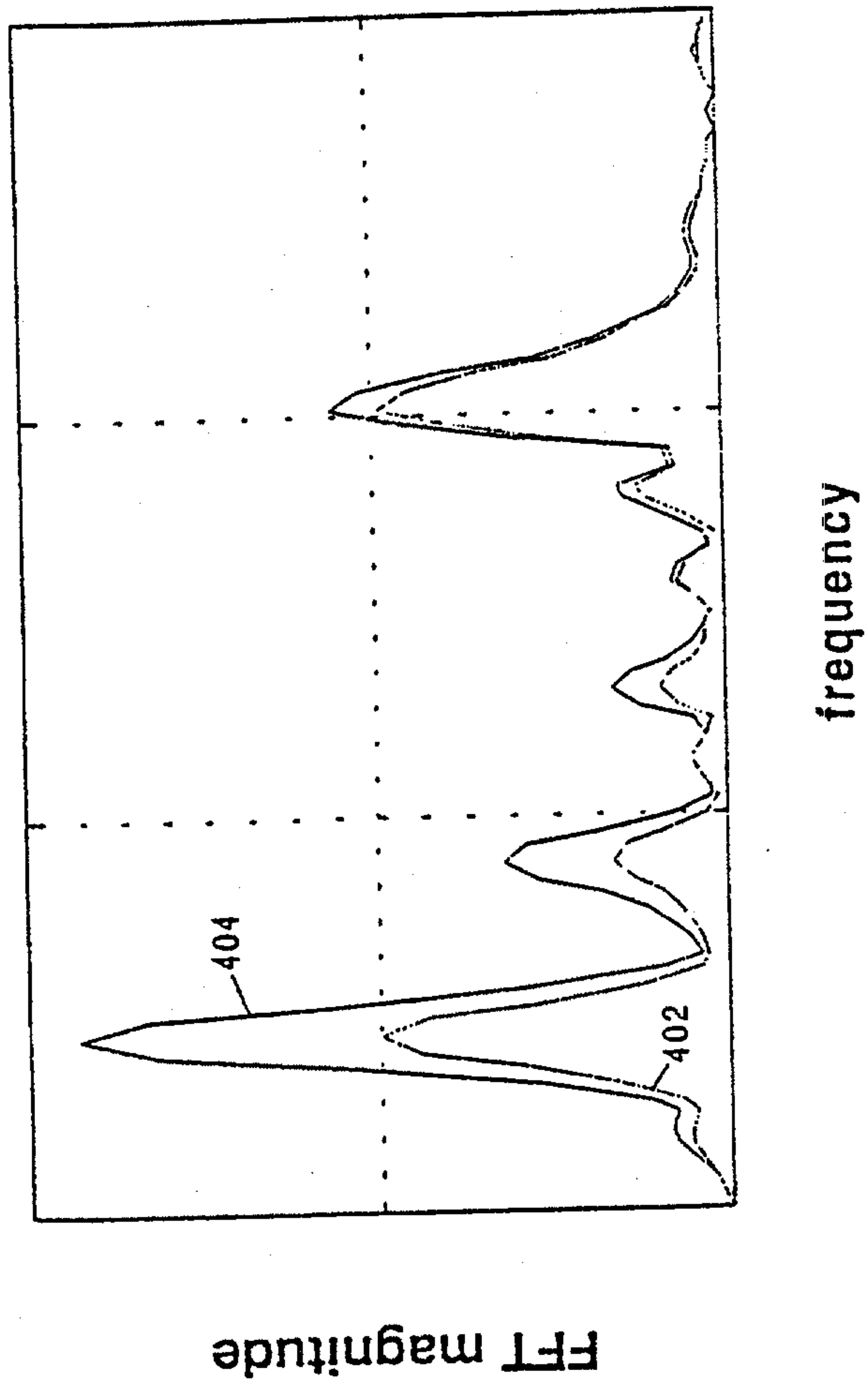
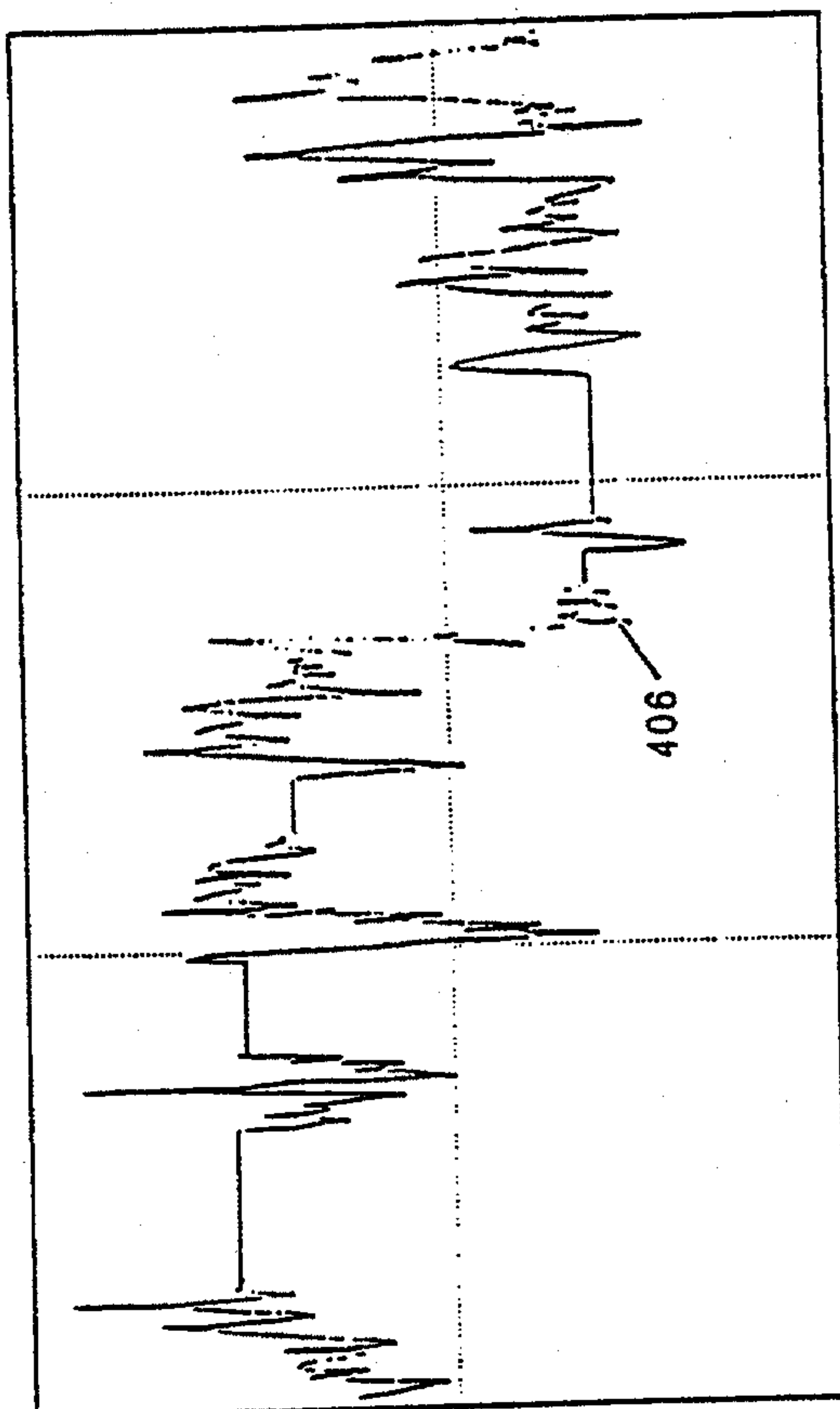

Fig. 4a



IR/red ratio (ω)

frequency

Fig. 4b

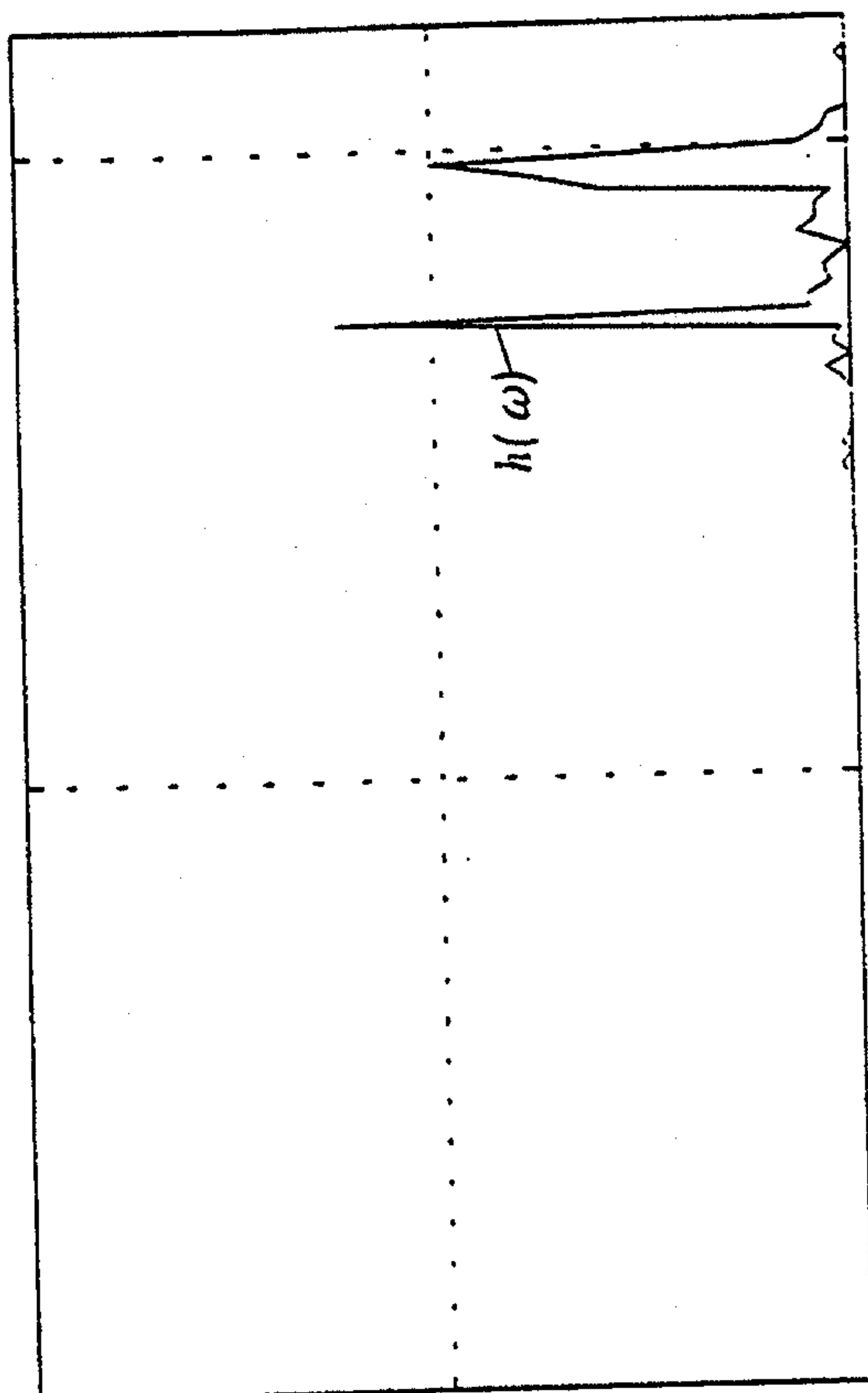

sat values

Fig. 4c

$\omega$

