

(19) World Intellectual Property Organization
International Bureau



(43) International Publication Date
21 February 2008 (21.02.2008)

PCT

(10) International Publication Number
WO 2008/021806 A3

(51) **International Patent Classification:**
F02B 25/28 (2006.01)

(21) **International Application Number:**
PCT/US2007/075321

(22) **International Filing Date:** 7 August 2007 (07.08.2007)

(25) **Filing Language:** English

(26) **Publication Language:** English

(30) **Priority Data:**
11/463,212 8 August 2006 (08.08.2006) US

(71) **Applicant (for all designated States except US):** INTERNATIONAL ENGINE INTELLECTUAL PROPERTY COMPANY, LLC [US/US]; 4201 Winfield Road, Warrenville, IL 60555 (US).

(72) **Inventors; and**

(75) **Inventors/Applicants (for US only):** SNYDER, W., Bryan [US/US]; 38569 Maes Street, Westland, MI 48186 (US). OLSZEWSKI, Robert, Z. [US/US]; 21W631 Glen Crest Drive, Glen Ellyn, IL 60137 (US).

(74) **Agents:** CALFA, Jeffrey P. et al.; International Engine Intellectual Property Company, LLC, 4201 Winfield Road, Warrenville, IL 60555 (US).

(81) **Designated States (unless otherwise indicated, for every kind of national protection available):** AE, AG, AL, AM, AT, AU, AZ, BA, BB, BG, BH, BR, BW, BY, BZ, CA, CH, CN, CO, CR, CU, CZ, DE, DK, DM, DO, DZ, EC, EE, EG, ES, FI, GB, GD, GE, GH, GM, GT, HN, HR, HU, ID, IL, IN, IS, JP, KE, KG, KM, KN, KP, KR, KZ, LA, LC, LK, LR, LS, LT, LU, LY, MA, MD, ME, MG, MK, MN, MW, MX, MY, MZ, NA, NG, NI, NO, NZ, OM, PG, PH, PL, PT, RO, RS, RU, SC, SD, SE, SG, SK, SL, SM, SV, SY, TJ, TM, TN, TR, TT, TZ, UA, UG, US, UZ, VC, VN, ZA, ZM, ZW

(84) **Designated States (unless otherwise indicated, for every kind of regional protection available):** ARIPO (BW, GH, GM, KE, LS, MW, MZ, NA, SD, SL, SZ, TZ, UG, ZM, ZW), Eurasian (AM, AZ, BY, KG, KZ, MD, RU, TJ, TM), European (AT, BE, BG, CH, CY, CZ, DE, DK, EE, ES, FI, FR, GB, GR, HU, IE, IS, IT, LT, LU, LV, MC, MT, NL, PL, PT, RO, SE, SI, SK, TR), OAPI (BF, BJ, CF, CG, CI, CM, GA, GN, GQ, GW, ML, MR, NE, SN, TD, TG).

Declaration under Rule 4.17:

— as to applicant's entitlement to apply for and be granted a patent (Rule 4.17(U))

Published:

— with international search report

[Continued on next page]

(54) **Title:** CRANKCASE FOR AN INTERNAL COMBUSTION ENGINE

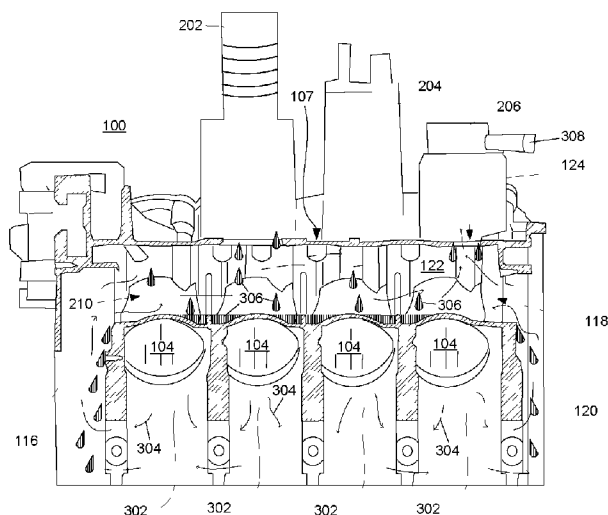

(57) **Abstract:** A crankcase (100) for an engine includes a first bank (102) of cylinders that has a plurality of cylinder bores (104) formed therein, and a second bank (102) of cylinders that includes an additional plurality of cylinder bores (104). The second bank (102) is at an angle with respect to the first bank (102). A valley structure (106) is located between the first bank (102) and the second bank (102). A gallery (122) is located between the first bank (102), the second bank (102), and the valley structure (106). The gallery (122) has at least one rear opening (118) that fluidly connects the gallery (102) to a rear portion (120) of the crankcase. At least one front opening (210) fluidly connects the gallery (122) to a front portion (116) of the crankcase (100). At least one breather opening (124) fluidly connects the gallery (122) to an outer valley surface (107).

WO 2008/021806 A3



— *before the expiration of the time limit for amending the claims and to be republished in the event of receipt of amendments*

(88) Date of publication of the international search report:
Y September 2008

INTERNATIONAL SEARCH REPORT

International application No

PCT/US07/75321

A CLASSIFICATION OF SUBJECT MATTER
 IPC F02B 25/28(2006 01)

 USPC 123/196R,196CP, 195R,572
 According to International Patent Classification (IPC) or to both national classification and IPC

B FIELDS SEARCHED
 Minimum documentation searched (classification system followed by classification symbols)
 U S 123/196R, 196CP, 195R, 572

 Documentation searched other than minimum documentation to the extent that such documents are included in the fields searched

 Electronic data base consulted during the international search (name of data base and, where practicable, search terms used)
 EAST crankcase v-type breather

C DOCUMENTS CONSIDERED TO BE RELEVANT

Category *	Citation of document, with indication, where appropriate, of the relevant passages	Relevant to claim No
X	US 4,656,991 A (FUKUO et al) 14 April 1987 (14 04 1987), Figures 2-5	1-15
X	JP 2005-9445 A (SUZUKI) 13 January 2005 (15 01 2005), Figures 1 & 9	1-15
A	US 6,571,763 A (BAKKER) 03 June 2003 (03 06 2003), Figures 1-3	1-15
A	US 5,069,192 A (MATSUMOTO et al) 03 December 1991 (03 12 1991), Figures 1-2	1-15
A	US 5,115,791 A (DORE) 26 May 1992 (26 05 1992), Figures 1-2	1-15
A	US 4,947,812 A (INOUE et al) 14 August 1990 (14 08 1990), Figures 2-3	1-15
A	US 4,541,399 A (TANAKA et al) 17 September 1985 (17 09 1985), Figure 1A	1-15

Further documents are listed in the continuation of Box C See patent family annex

Special categories of cited documents	"T"	later document published after the international filing date or priority date and not in conflict with the application but cited to understand the principle or theory underlying the invention
"A" document defining the general state of the art which is not considered to be of particular relevance	"X"	document of particular relevance, the claimed invention cannot be considered novel or cannot be considered to involve an inventive step when the document is taken alone
"E" earlier application or patent published on or after the international filing date	"Y"	document of particular relevance, the claimed invention cannot be considered to involve an inventive step when the document is combined with one or more other such documents, such combination being obvious to a person skilled in the art
"L" document which may throw doubts on priority claim(s) or which is cited to establish the publication date of another citation or other special reason (as specified)	"&"	document member of the same patent family
"O" document referring to an oral disclosure, use, exhibition or other means		
"P" document published prior to the international filing date but later than the priority date claimed		

Date of the actual completion of the international search 23 April 2008 (23 04 2008)	Date of mailing of the international search report 07 JUL 2008
Name and mailing address of the ISA/US Mail Stop PCT, Attn ISA/US Commissioner for Patents P O Box 1450 Alexandria, Virginia 22313-1450 Facsimile No (571) 273-3201	Authorized officer Hai Huynh Telephone No (75 1) 272-4383