



(51) International Patent Classification:

A01C 1/00 (2006.01) A01P 3/00 (2006.01)
A01N 25/00 (2006.01) A01P 7/04 (2006.01)

(21) International Application Number:

PCT/US2016/048218

(22) International Filing Date:

23 August 2016 (23.08.2016)

(25) Filing Language:

English

(26) Publication Language:

English

(30) Priority Data:

62/209,179 24 August 2015 (24.08.2015) US

(71) Applicants: **PIONEER HI-BRED INTERNATIONAL, INC.** [US/US]; 7100 N.W. 62nd Avenue, Johnston, Iowa 50131-1014 (US). **E. I. DU PONT DE NEMOURS AND COMPANY** [US/US]; Chestnut Run Plaza, 974 Centre Road, P. O. Box 2915, Wilmington, Delaware 19805 (US).

(72) Inventors: **DAMMEN, Michael**; 7250 NW 62nd Ave., Johnston, Iowa 50131 (US). **DANIELS, Jeffrey Lee**; 7250 NW 62nd Ave., Johnston, Iowa 50131 (US). **GEIGLE, William L.**; Chestnut Run Plaza, 974 Centre Road, Wilmington, Delaware 19805 (US). **SEABA, Randy**; 7250 NW 62nd Ave., Johnston, Iowa 50131 (US). **MCCAFFERY, Sean Fuller**; Chestnut Run Plaza, 974 Centre Road, Wilmington, Delaware 19805 (US).

(74) Agent: **DEVADAS, Sendil K.**; PIONEER HI-BRED INTERNATIONAL, INC., 7100 N.W. 62nd Avenue, Johnston, Iowa 50131-1014 (US).

(81) Designated States (unless otherwise indicated, for every kind of national protection available): AE, AG, AL, AM, AO, AT, AU, AZ, BA, BB, BG, BH, BN, BR, BW, BY, BZ, CA, CH, CL, CN, CO, CR, CU, CZ, DE, DK, DM, DO, DZ, EC, EE, EG, ES, FI, GB, GD, GE, GH, GM, GT, HN, HR, HU, ID, IL, IN, IR, IS, JP, KE, KG, KN, KP, KR, KZ, LA, LC, LK, LR, LS, LU, LY, MA, MD, ME, MG, MK, MN, MW, MX, MY, MZ, NA, NG, NI, NO, NZ, OM, PA, PE, PG, PH, PL, PT, QA, RO, RS, RU, RW, SA, SC, SD, SE, SG, SK, SL, SM, ST, SV, SY, TH, TJ, TM, TN, TR, TT, TZ, UA, UG, US, UZ, VC, VN, ZA, ZM, ZW.

(84) Designated States (unless otherwise indicated, for every kind of regional protection available): ARIPO (BW, GH, GM, KE, LR, LS, MW, MZ, NA, RW, SD, SL, ST, SZ, TZ, UG, ZM, ZW), Eurasian (AM, AZ, BY, KG, KZ, RU, TJ, TM), European (AL, AT, BE, BG, CH, CY, CZ, DE, DK, EE, ES, FI, FR, GB, GR, HR, HU, IE, IS, IT, LT, LU, LV, MC, MK, MT, NL, NO, PL, PT, RO, RS, SE, SI, SK, SM, TR), OAPI (BF, BJ, CF, CG, CI, CM, GA, GN, GQ, GW, KM, ML, MR, NE, SN, TD, TG).

Published:

— with international search report (Art. 21(3))

[Continued on next page]

(54) Title: METHODS AND SYSTEMS FOR SEED TREATMENT APPLICATIONS

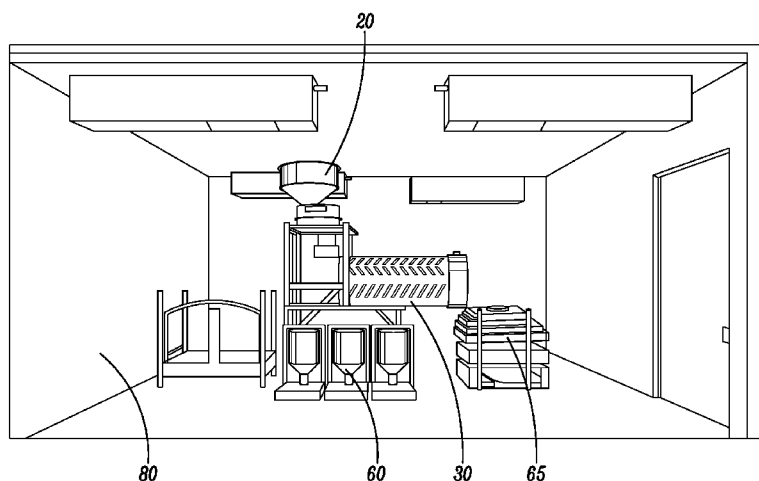

FIG. 3

(57) Abstract: Methods and systems to improve application of seed applied components to seeds are disclosed. Environmentally controlled enclosures to test, evaluate and develop seed treatment solutions for certain geographical locations are provided. Controlled environments during seed treatment application process in a production location improves the overall seed treatment efficiency and uniformity.



- *before the expiration of the time limit for amending the claims and to be republished in the event of receipt of amendments (Rule 48.2(h))*

TITLE

METHODS AND SYSTEMS FOR SEED TREATMENT APPLICATIONS

FIELD

The field relates to application of seed treatments.

5

BACKGROUND

Crop seeds that are planted for agricultural purposes are treated with a variety of seed treatment products that offer benefit from early season pests and diseases in addition to enhancing seed germination and seedling vigor. These seed treatment products include for example, fungicides, insecticides, nematicides, biologicals and other components that improve general plant health. Treatments can also include nutrients including fertilizer. Crop seeds are often treated at production plants where the seeds are routinely produced and packaged for distribution. Crop seeds are also treated at retail locations and on-farm locations where applicable. Applying seed treatment products to seeds depend on a variety of environmental factors such as temperature, humidity, atmospheric pressure and others. Over or under application of seed treatment products may result in discarding treated seeds and operational inefficiency. Such environmental factors vary across geographies and impact seed treatment applications that involve more than one seed treatment product. Therefore, controlling such environmental factors during seed treatment applications or developing formulations that work better in certain environmental conditions are desirable.

10

15

20

SUMMARY

A method of applying one or more components to a plurality of seeds, the method includes providing the one or more components and coating the one of more components to the plurality of seeds in a seed treating equipment, wherein in the seed treating equipment is housed in an environmentally controlled chamber and wherein the chamber is designed to modulate one or more environmental conditions selected from the group consisting of temperature, humidity, and barometric pressure.

25

30

A method of controlling humidity and temperature during a seed treatment operation, the method includes (a) applying one or more seed treatment products to a plurality of seeds wherein the seed treatment application is performed using a seed treatment equipment substantially housed within an environmentally controlled

chamber; and (b) controlling the humidity and temperature during the seed treatment operation and wherein the humidity and temperature are selected to optimize the seed treatment operation for the seed treatment products.

A method of developing a seed treatment product, the method includes (a) applying one or more test seed treatment formulations to a plurality of seeds wherein the seed treatment application is performed using a seed treatment equipment substantially housed within an environmentally controlled chamber; (b) modulating one or more environmental conditions selected from the group consisting of temperature, humidity, and barometric pressure during the seed treatment operation; and (c) developing the seed treatment product based on the performance of the test seed treatment formulations in the tested environmental conditions.

A method of treating seeds in a production plant with one or more seed treatment products, the method includes (a) applying the one or more seed treatment products to the seeds in a continuous flow seed treating equipment, wherein the seed treating equipment is substantially housed within an environmentally controlled enclosure and the seed treating equipment handles continuous flow of seeds; and (b) maintaining the temperature and/or humidity in the enclosure to a previously determined optimal range during the seed treatment application.

An environmentally controlled seed treatment system for treating seeds at a production location or a testing location, the system includes:

- a. a seed treating equipment configured to apply a plurality of seed applied components to a plurality of seeds;
- b. a climate controlled chamber to substantially enclose the seed treating equipment, wherein the chamber is capable of maintaining a desired range of temperatures and humidity for a particular seed treatment recipe;
- c. a sensor disposed within the chamber, the sensor selected from the group consisting of temperature, humidity, barometric pressure, and air flow sensors;
- d. a plurality of containers having the plurality of seed applied components to apply the seed applied components into the seed treating equipment; and
- e. conveyor system to transfer the plurality of seeds treated with the seed applied components.

A method of treating seeds at a seed production facility for delivery of the treated seeds to a customer, the method includes: providing a seed treatment recipe comprising one or more seed applied components; maintaining appropriate temperature and humidity based on the seed treatment recipe in an area enclosing a seed treatment equipment; and operating the seed treatment equipment to produce treated seeds for the customer.

In an embodiment, the environmental condition is modulated based on previously determined optimal environmental conditions. In an embodiment, the optimal conditions are based on geographical location, timing of application, presence or absence of one or more seed applied components or formulations thereof, type of seeds, seed size, seed shape, volume of seeds being treated, seed treatment rate, nature of the seed treating equipment and volume of the chamber.

In an embodiment, the seeds are selected from the group consisting of corn, soybean, canola, rice, wheat, sorghum, sunflower and alfalfa.

In an embodiment, the coating is performed in a continuous flow seed treating equipment.

In an embodiment, the coating is performed in a batch seed treating equipment

In an embodiment, the chamber containing the seed treating equipment is portable.

In an embodiment, a sensor selected from the group consisting of temperature, humidity, barometric pressure, air flow, and a combination thereof is disposed within the chamber. In an embodiment, the sensor is not disposed within the seed treating equipment.

In an embodiment, the treating drum portion of the seed treating equipment is housed within the environmentally controlled chamber.

In an embodiment, the seed treatment products are in containers that are positioned outside the environmentally controlled chamber.

In an embodiment, the environmental conditions are based on humidity and temperature values suitable for a geographical region where the seed treatment operation is performed.

In an embodiment, the performance of the test seed treatment formulation is evaluated based on a criteria selected from the group consisting of flowability,

plantability, tachyness, seed coating uniformity, dust-off levels, application accuracy of labeled rates and treated seed appearance.

In an embodiment, the test formulation for seed treatment is evaluated at a particular humidity level in the chamber, wherein the humidity level is predetermined
5 based on historical humidity levels for a particular geographical region.

In an embodiment, the humidity in the chamber is adjusted based on a binder or a polymer used in the seed treatment operation.

In an embodiment, the seed treatment equipment comprises a portion where the seed treatment products contact the seeds and wherein the portion is positioned
10 within the environmentally controlled enclosure.

In an embodiment, the humidity within the enclosure is set based on the seed treatment product.

In an embodiment, the humidity within the enclosure is controlled based on the type of seed that is being treated.

In an embodiment, the seed treatment system includes a seed treatment
15 equipment that is a continuous flow seed treater. In an embodiment, the seed treatment equipment is an unitized batch treater. In an embodiment, the seed treatment equipment comprises a drum treater. In an embodiment, the seed treatment system includes receiving stations for the plurality of stations that are
20 positioned outside the climate controlled chamber.

In an embodiment, the plurality of stations include a seed treatment product selected from the group consisting of an insecticide, a fungicide, and a biological component.

In an embodiment, the sensor is connected to a remote computer network.

In an embodiment, the a conveyor system transfers treated seeds to a seed
25 drying station.

A method of applying a seed treatment product to a plurality of corn seeds at a production plant, the method includes:

- a. providing a plurality of corn seeds and one or more seed treatment
30 products;
- b. contacting the corn seeds with the one or more seed treatment products in a seed treatment equipment, wherein the seed treatment equipment is positioned within a climate controlled enclosure; and

c. maintaining an appropriate temperature and humidity in the climate controlled enclosure during the seed treatment application, wherein the temperature and humidity is set based on a prior evaluation with one or more seed treatment products.

5 In an embodiment, the corn seeds are hybrid seeds. In an embodiment, the corn seeds are inbred seeds. In an embodiment, the corn seeds are transgenic seeds comprising a trait selected from the group consisting of herbicide tolerance, insect resistance, and an agronomic trait.

10 In an embodiment, one or more seed treatment products comprise an insecticide selected from the group consisting of thiamethoxam, clothianidin, chlorantraniliprole, cyantraniliprole, butenolide, and acetamprid. In an embodiment, one or more seed treatment products comprise a fungicide selected from the group consisting of azoxystrobin, fludioxonil, mefenoxam, thiabendazole, tebuconazol, penthiopyrad and oxathiapiprolin.

15 A method of increasing crop yield, the method includes:

a. treating a plurality of crop seeds with one or more seed treatment products, wherein the treating is performed using a seed treating equipment positioned within a climate controlled enclosure such that the seed treatment products applied to the seeds are within about -2% to about +2% as compared to the label application rate; and

20

b. providing the treated seeds to a crop growing customer for planting in a crop growing environment, thereby increasing the crop yield.

In an embodiment, the seed treatment products applied to the seeds are within about -1% to about +1% or within about -0.5% to about +0.5% of the label application rate.

25

In an embodiment, the climate controlled enclosure comprises a humidity sensor. In an embodiment, the climate controlled enclosure is capable of adjusting temperature and humidity based on the type of seed treatment products used.

An environmentally controlled seed treatment system at a seed production facility for delivery of treated seeds to a grower, the system comprising:

30

a. a seed treating equipment configured to apply a plurality of seed applied components to a plurality of seeds;

b. a first climate controlled chamber to substantially enclose the seed treating equipment, wherein the chamber is capable of maintaining a desired range of temperatures and humidity;

5 c. a sensor disposed within the chamber, the sensor selected from the group consisting of temperature, humidity, barometric pressure, and air flow sensors.

In an embodiment, the seed treatment equipment in the environmentally controlled seed treatment system is a continuous flow seed treater. In an embodiment, the seed treatment equipment in the environmentally controlled seed treatment system is an unitized batch treater. In an embodiment, the seed treatment equipment in the environmentally controlled seed treatment system comprises a drum treater.

15 In an embodiment, the chamber is capable of maintaining a temperature range that is about 10°C to about 22°C when the seed treating equipment is in operation. In an embodiment, the chamber is capable of maintaining a humidity range that is about 30% to about 40% humidity when the seed treating equipment is in operation.

20 In an embodiment, the chamber is capable of maintaining a temperature range that is equal to or less than about 25°C and a humidity range that is equal to or less than 40 % humidity when the seed treating equipment is in operation. In an embodiment, the seed treatment system includes both a temperature and a humidity sensor. In an embodiment, the seed treatment system further includes an air flow sensor. In an embodiment, the seed treatment further comprises a barometric pressure sensor.

25 In an embodiment, the seed treatment system further includes at least one seed treatment product storage station positioned in the first climate controlled chamber.

30 In an embodiment, the seed treatment system further includes at least one seed treatment product storage station positioned in a second climate controlled chamber located outside the first climate controlled chamber.

An environmentally controlled seed treatment system at a seed production facility for delivery of treated seeds to a grower, the system includes:

a. a seed treating equipment configured to apply a plurality of seed applied components to a plurality of seeds;

b. a plurality of climate controlled chambers to substantially enclose the seed treating equipment, wherein the plurality of the chamber are capable of maintaining a plurality of desired ranges of temperatures and humidity;

c. a sensor disposed within the chamber, the sensor selected
5 from the group consisting of temperature, humidity, barometric pressure, and air flow sensors.

BRIEF DESCRIPTION OF THE DRAWINGS

Fig . 1 shows a schematic illustration of a seed treatment application system
10 in an environmentally controlled enclosure.

Fig . 2 shows a schematic illustration of a seed treatment application system in an environmentally controlled enclosure, where containers for seed treatment products are positioned outside the enclosure.

Fig. 3 shows an illustration of a set up of an climate-controlled environmental
15 chamber that contains a drum seed treater and a fluidized bed dryer.

DETAILED DESCRIPTION

Methods and systems for seed treatment applications are disclosed.

The contents and disclosures of priority application, U.S. Ser. No.
20 62/209,179 are incorporated herein by reference.

In an embodiment, a method of applying one or more components to a plurality of seeds includes providing the one or more components and coating the one of more components to the plurality of seeds in a seed treating equipment, wherein the seed treating equipment is housed in an environmentally controlled
25 chamber and wherein the chamber is designed to modulate one or more environmental conditions selected from the group consisting of temperature, humidity, and barometric pressure. In an embodiment, the chamber is a climate controlled room within an existing facility. In an embodiment, the chamber is a climate controlled facility that can maintain a desired operating ranges of humidity
30 and temperatures.

A method of controlling humidity and temperature during a seed treatment operation includes (a) applying one or more seed treatment products to a plurality of seeds wherein the seed treatment application is performed using a seed treatment equipment substantially housed within an environmentally controlled chamber; and

(b) controlling the humidity and temperature during the seed treatment operation and wherein the humidity and temperature are selected to optimize the seed treatment operation for the seed treatment products. In an embodiment, the environmentally controlled chamber partially houses the seed treating equipment such that only the drum portion is climate-controlled as opposed to the entire seed treating equipment including the hopper and the conveyor systems.

A method of developing a seed treatment product includes (a) applying one or more test seed treatment formulations to a plurality of seeds wherein the seed treatment application is performed using a seed treatment equipment substantially housed within an environmentally controlled chamber; (b) modulating one or more environmental conditions selected from the group consisting of temperature, humidity, and barometric pressure during the seed treatment operation; and (c) developing the seed treatment product based on the performance of the test seed treatment formulations in the tested environmental conditions. Factors such as temperature and humidity are varied incrementally and the performance characteristics of one or more seed treatment formulations are evaluated. In an embodiment, the active ingredient (e.g., an insecticide or a fungicide or a combination of both) concentration is kept constant while other components such as application rate, polymer type/amount and any binders are varied. In an embodiment, the active ingredient concentration is also adjusted to get a desirable loading concentration (e.g., $\mu\text{g a.i./seed}$).

A method of treating seeds in a production plant with one or more seed treatment products, the method includes (a) applying the one or more seed treatment products to the seeds in a continuous flow seed treating equipment, wherein the seed treating equipment is substantially housed within an environmentally controlled enclosure and the seed treating equipment handles continuous flow of seeds; and (b) maintaining the temperature and/or humidity in the enclosure to a previously determined optimal range during the seed treatment application. In an embodiment, the optimal range is determined by evaluating the seed treatment products within a desirable range of temperature and humidity to achieve a desired loading rate, appearance, dust-off levels, retention of active ingredients on the seed, and bioavailability of any biological components.

An environmentally controlled seed treatment system for treating seeds at a production location or a testing location includes:

- a. a seed treating equipment configured to apply a plurality of seed applied components to a plurality of seeds;
- b. a climate controlled chamber to substantially enclose the seed treating equipment, wherein the chamber is capable of maintaining a desired range of temperatures and humidity for a particular seed treatment product or a seed treatment recipe that includes more than product;
- c. a sensor disposed within the chamber, the sensor selected from the group consisting of temperature, humidity, barometric pressure, and air flow sensors;
- d. a plurality of containers having the plurality of seed applied components to apply the seed applied components into the seed treating equipment; and
- e. conveyor system to transfer the plurality of seeds treated with the seed applied components.

In an embodiment, the one or more seed treatment products may be pre-mixed or mixed at the site of treating before being applied inside the seed treatment equipment. In an embodiment, the containers comprise a prescriptive seed treatment system where an appropriate amount of one or more seed applied component to be automatically injected in a closed loop system into the seed treatment equipment. In an embodiment, the prescriptive seed treatment system is controlled by a remote computer server capable of providing instructions and obtaining data regarding the seed treatment products used to and from the prescriptive seed treatment system. Such automated seed treatment systems are adaptable for production location as well as on site operations at a customer or retail level.

In an embodiment, a sensor disposed within the climate-controlled chamber or enclosure is in communication through a computer network to feed data such that the seed treatment application can be controlled. For example, data from one or more sensors disposed within the chamber are analyzed to adjust the seed treatment application rate, addition or removal of one or more components such as a binder from the seed treatment recipe.

A method of treating seeds at a seed production facility for delivery of the treated seeds to a customer, the method includes: providing a seed treatment recipe comprising one or more seed applied components; maintaining appropriate

temperature and humidity based on the seed treatment recipe in an area enclosing a seed treatment equipment; and operating the seed treatment equipment to produce treated seeds for the customer. In an embodiment, the area enclosing the seed treatment equipment is a room with HVAC (heating, ventilation, air
5 conditioning) systems to maintain a desired range of humidity and temperature.

In an embodiment, the environmental condition is modulated based on previously determined optimal environmental conditions. In an embodiment, the optimal conditions are based on geographical location, timing of application, presence or absence of one or more seed applied components or formulations
10 thereof, type of seeds, seed size, seed shape, volume of seeds being treated, seed treatment rate, nature of the seed treating equipment and volume of the chamber.

In an embodiment, the seeds that are treated or coated with a seed treatment product or a seed applied component are selected from the group consisting of corn, soybean, canola, rice, wheat, sorghum, sunflower and alfalfa.

15 In an embodiment, the coating is performed in a continuous flow seed treating equipment. Continuous flow seed treating equipment are available commercially from vendors. For example, a commercial continuous flow seed treating equipment may include a distribution device that modulates the incoming seed flow rates and appropriately distributes the seed flow into a uniform seed layer
20 where the seed treatment products are applied. seed treating equipment may include an applicator head or an atomizer disc to atomizes and apply a uniform, even distribution of the seed applied components to the seed layer (or a screen of seeds) to coat the seed and further progress the seed treatment process within the drum. In an embodiment, the seed treating equipment may include a drum that
25 mixes the seeds coated with the seed treatment products, using mixing paddles and distribution baffles to control the flow of treated seed. In an embodiment, during the discharge process, treated seeds are transferred to the conveyor system.

In an embodiment, the coating is performed in a batch seed treating equipment. In an embodiment, the chamber containing the seed treating equipment
30 is portable.

In an embodiment, the chamber comprises a sensor selected from the group consisting of temperature, humidity, barometric pressure, and air flow. The sensors may be connected to a common network to feed data that enables the microprocessor-based control systems to accordingly adjust the temperature,

humidity, air flow, and barometric pressure to maintain a desired range within the enclosure. The environmental conditions present within the enclosure or the climate-controlled chamber can also be adjusted depending on the micro-climate conditions present within the seed treating equipment, e.g., inside the drum of a
5 seed treater.

In an embodiment, the treating drum portion of the seed treating equipment is housed within the environmentally controlled chamber. In an embodiment, the seed treatment products are in containers that are positioned outside the environmentally controlled chamber. In an embodiment, the environmental
10 conditions are based on humidity and temperature values suitable for a geographical region where the seed treatment operation is performed.

In an embodiment, the performance of the test seed treatment formulation is evaluated based on a criteria selected from the group consisting of flowability, plantability, tachyness, seed coating uniformity, retention of active ingredients, dust-
15 off levels, application accuracy of labeled rates and treated seed appearance.

In an embodiment, the test formulation for seed treatment is evaluated at a particular humidity level in the chamber, wherein the humidity level is predetermined based on historical humidity levels for a particular geographical region. Historic humidity levels for a particular location and time of the year are obtained from
20 weather reporting station records. Similarly, historic temperature levels are also obtained from such weather reports. Based on the those weather data, conditions prevailing within a seed treatment facility e.g., a building, is modeled to obtain ranges of operating weather conditions that exist during seed treatment operations in the building.

In an embodiment, the humidity in the chamber is adjusted based on a binder or a polymer used in the seed treatment operation. In an embodiment, the seed treatment equipment comprises a portion where the seed treatment products contact the seeds and wherein the portion is positioned within the environmentally controlled enclosure. In an embodiment, humidity levels within the chamber may
30 impact the flow of the seed treatment slurry and how uniform of a coating the seeds get during the seed treatment process. In an embodiment, based on the

In an embodiment, the humidity within the enclosure is set based on the seed treatment product. In an embodiment, the humidity within the enclosure is controlled based on the type of seed that is being treated.

In an embodiment, the seed treatment system includes a seed treatment equipment that is a continuous flow seed treater. In an embodiment, the seed treatment equipment is an unitized batch treater. In an embodiment, the seed treatment equipment comprises a drum treater. In an embodiment, the seed treatment system includes receiving stations for the plurality of stations that are positioned outside the climate controlled chamber.

In an embodiment, the plurality of stations include a seed treatment product selected from the group consisting of an insecticide, a fungicide, and a biological component.

In an embodiment, the sensor is connected to a remote computer network.

In an embodiment, the a conveyor system transfers treated seeds to a seed drying station.

A method of applying a seed treatment product to a plurality of corn seeds at a production plant, the method includes:

- a. providing a plurality of corn seeds and one or more seed treatment products;
- b. contacting the corn seeds with the one or more seed treatment products in a seed treatment equipment, wherein the seed treatment equipment is positioned within a climate controlled enclosure; and
- c. maintaining an appropriate temperature and humidity in the climate controlled enclosure during the seed treatment application, wherein the temperature and humidity is set based on a prior evaluation with one or more seed treatment products.

In an embodiment, the corn seeds are hybrid seeds. In an embodiment, the corn seeds are inbred seeds. In an embodiment, the corn seeds are transgenic seeds comprising a trait selected from the group consisting of herbicide tolerance, insect resistance, and an agronomic trait.

In an embodiment, one or more seed treatment products comprise an insecticide selected from the group consisting of thiamethoxam, clothianidin, chlorantraniliprole, cyantraniliprole, butenolide, and acetamprid. In an embodiment, one or more seed treatment products comprise a fungicide selected from the group consisting of azoxystrobin, fludioxonil, mefenoxam, thiabendazole, tebuconazol, penthiopyrad and oxathiapiprolin.

A method of increasing crop yield, the method includes:

a. treating a plurality of crop seeds with one or more seed treatment products, wherein the treating is performed using a seed treating equipment positioned within a climate controlled enclosure such that the seed treatment products applied to the seeds are within about -2% to about +2% as compared to the label application rate; and

b. providing the treated seeds to a crop growing customer for planting in a crop growing environment, thereby increasing the crop yield.

In an embodiment, the seed treatment products applied to the seeds are within about -1% to about +1% or within about -0.5% to about +0.5% of the label application rate.

In an embodiment, the climate controlled enclosure comprises a humidity sensor. In an embodiment, the climate controlled enclosure is capable of adjusting temperature and humidity based on the type of seed treatment products used.

An environmentally controlled seed treatment system at a seed production facility for delivery of treated seeds to a grower, the system comprising:

a. a seed treating equipment configured to apply a plurality of seed applied components to a plurality of seeds;

b. a first climate controlled chamber to substantially enclose the seed treating equipment, wherein the chamber is capable of maintaining a desired range of temperatures and humidity;

c. a sensor disposed within the chamber, the sensor selected from the group consisting of temperature, humidity, barometric pressure, and air flow sensors.

In an embodiment, the seed treatment equipment in the environmentally controlled seed treatment system is a continuous flow seed treater. In an embodiment, the seed treatment equipment in the environmentally controlled seed treatment system is an unitized batch treater. In an embodiment, the seed treatment equipment in the environmentally controlled seed treatment system comprises a drum treater.

In an embodiment, the chamber is capable of maintaining a temperature range that is about 10°C to about 22°C when the seed treating equipment is in operation. In an embodiment, the chamber is capable of maintaining a humidity range that is about 30% to about 40% humidity when the seed treating equipment is in operation.

In an embodiment, the chamber is capable of maintaining a temperature range that is equal to or less than about 25°C and a humidity range that is equal to or less than 40% humidity when the seed treating equipment is in operation. In an embodiment, the seed treatment system includes both a temperature and a humidity sensor. In an embodiment, the seed treatment system further includes an air flow sensor. In an embodiment, the seed treatment further comprises a barometric pressure sensor.

In an embodiment, the seed treatment system further includes at least one seed treatment product storage station positioned in the first climate controlled chamber.

In an embodiment, the seed treatment system further includes at least one seed treatment product storage station positioned in a second climate controlled chamber located outside the first climate controlled chamber.

An environmentally controlled seed treatment system at a seed production facility for delivery of treated seeds to a grower, the system includes:

- a. a seed treating equipment configured to apply a plurality of seed applied components to a plurality of seeds;
- b. a plurality of climate controlled chambers to substantially enclose the seed treating equipment, wherein the plurality of the chamber are capable of maintaining a plurality of desired ranges of temperatures and humidity;
- c. a sensor disposed within the chamber, the sensor selected from the group consisting of temperature, humidity, barometric pressure, and air flow sensors

In an embodiment, multiple chambers are arranged in a series so that treated seeds from a seed treatment equipment in the first chamber is conveyed to a second chamber where a different humidity and/or temperature level is maintained to apply a second seed treatment product that is different than a first seed treatment product applied within the first chamber. Optionally, one of the chambers housing a seed treatment equipment may not be climate controlled compared to another chamber that is climate-controlled. For example, an insecticide seed treatment is applied under temperature and humidity levels in a first chamber that are different than the temperature humidity levels in a second chamber where a biological seed treatment is applied.

In an embodiment, a method of evaluating the performance of a seed treatment product under a predetermined environmental condition, the method

comprising (a) applying the seed treatment product to a plurality of seeds wherein the seed treatment application is performed using a seed treatment equipment substantially housed within an environmentally controlled chamber; (b) maintaining the predetermined environmental condition selected from the group consisting of
5 temperature, humidity, and barometric pressure during the seed treatment operation, wherein the environmental condition is predetermined based on the environmental condition present in a geographical region; and (c) evaluating the performance of the seed treatment product in the predetermined environmental condition. In an embodiment, the geographical region is characterized as tropical. In
10 an embodiment, the geographical region is characterized as arid.

In an embodiment, the climate controlled enclosure is located at a seed production plant. In an embodiment, the climate controlled enclosure is portable. In an embodiment, the climate controlled enclosure is mounted on one of a trailer and a self-propelled vehicle. In an embodiment, the climate controlled enclosure is sized
15 to house the seed treatment container. In an embodiment, the climate controlled enclosure is sized to house the seed treatment products. In an embodiment, the climate controlled enclosure is sized to house a seed treatment container. In an embodiment, the climate controlled enclosure maintains the seed treatment equipment at a predetermined temperature. In an embodiment, the climate
20 controlled enclosure is located between a source of seed treatment and the seed treatment container, the climate controlled enclosure having a control module to maintain the seed treatment entering the seed treatment container at the predetermined temperature. In an embodiment, the climate controlled enclosure includes a conditioner to increase or decrease humidity of air within the seed
25 treatment container. In an embodiment, the climate controlled enclosure includes a sensor to determine an environmental condition. In an embodiment, the sensor is located within the seed treatment container. In an embodiment, the sensor is located adjacent to the seed treatment container. In an embodiment, the sensor is located adjacent a source of seed treatment. In an embodiment, the sensor is
30 located within the seed treatment container. In an embodiment, the sensor is determines one of temperature, humidity, and atmospheric pressure. In an embodiment, the sensor is connected with the controller. In an embodiment, the climate controlled enclosure is connected with one of a gas source, a humidifier, a dehumidifier, heat exchanger, and a heater. In an embodiment, the climate

controlled enclosure is connected with a controller for controlling one of temperature, humidity, and atmospheric pressure within the climate controlled enclosure. In an embodiment, the controller is connected with a plurality of sensors, the sensors measure one of temperature, humidity, and atmospheric pressure
5 within and outside of the climate controlled enclosure. In an embodiment, the step of maintaining an environmental condition includes adjusting one of temperature, humidity, and atmospheric pressure within the climate controlled enclosure based on the difference between the measured one of temperature, humidity, and
10 atmospheric pressure and one of a predetermined temperature, humidity, and atmospheric pressure. In an embodiment, the controller includes a predetermined one of temperature, humidity, and atmospheric pressure level.

In an embodiment, maintenance of a desirable environmental condition includes comparing a measured temperature, humidity, and atmospheric pressure with a predetermined one of temperature, humidity, and atmospheric pressure. In an
15 embodiment, maintenance of a desirable environmental condition includes adjusting one of temperature, humidity, and atmospheric pressure based on a measured one of temperature, humidity, and atmospheric pressure being one of higher or lower than a predetermined one of temperature, humidity, and atmospheric pressure. In an embodiment, the predetermined one of temperature, humidity, and atmospheric
20 pressure includes a range temperatures, humidity, and atmospheric pressures. In an embodiment, one of temperature, humidity, and atmospheric pressure within the climate controlled enclosure is adjusted based, in part, on change in a measured one of temperature, humidity, and atmospheric pressure outside of the climate controlled enclosure. In an embodiment, the controller is connected with one of a
25 gas source, a humidifier, a dehumidifier, heat exchanger, and a heater to one of increase and decrease one of temperature, humidity, and atmospheric pressure within the climate controlled enclosure. In an embodiment, the climate controlled enclosure is located within a housing to provide a separating barrier between the climate controlled enclosure and external elements. In an embodiment, a source of
30 seed treatment is located within a housing to provide a separating barrier between the climate controlled enclosure and external elements. In an embodiment, an intermediate connection between the climate controlled enclosure and a source of seed treatment is located within a housing to provide a separating barrier between intermediate connection and external elements.

The components identified in the drawings are for illustration purposes only and are not intended to depict scale or operational accuracy for the non-identified components. In an illustrated embodiment shown in **FIG. 1**, plurality of seeds **10** enter a hopper **20** associated with a seed treating equipment **30**. The seeds can be treated either continuously or in a batch operation. In the embodiment shown in **FIG. 1**, the seed treating equipment **30** includes a rotary drum treater. Other treaters such as for example, an unitary batch treater or a continuous flow treater are also within the scope of this disclosure. Further, lab-scale bench seed treaters may also be suitable to operate within the scope of this disclosure. An atomizer **40** to provide the seed treatment products is coupled to the seed treating equipment **30**. Seed treatment products are stored in one or more containers **60** and they are pumped or transferred from the containers **60** to the atomizer **40** through one or more connected channels **70**. These channels **70** may be made of flexible connectors that are removably connected to the containers **60** and to the seed treating equipment **30** through the atomizer **40** in a closed loop system to reduce exposure of the seed treatment products. The seed treating operation where the seeds are exposed to one or more seed applied components such as, e.g., insecticides, fungicides, biologicals, and polymers is performed for a suitable period, ranging from several minutes to a few hours. The duration may depend on the volume of seeds to be treated, quantity of seed treatment used, environmental factors such as humidity, temperature, the size of the seed treating equipment and the seed type. The treated seed (not shown in the illustrated drawings) is transferred out of the seed treating equipment **30** through outlet **50** for further handling such as for example, drying. In the illustrated embodiment shown in **FIG. 1**, the seed treating equipment **30** and the containers **60** are positioned within a climate controlled enclosure **80**. The climate controlled enclosure **80** includes for example, an environmental chamber or a designated room that houses seed treating components, wherein the chamber or room is specifically designed to regulate humidity and temperatures to simulate conditions occurring in various geographies.

As shown in **FIG.1**, the climate controlled enclosure **80** has one or more sensors **90** disposed within the enclosure. In an embodiment, the sensors **90** include for example, a humidity sensor, a temperature sensor, an air flow sensor, a GPS, barometric pressure sensor, and a combination thereof. In an embodiment, the enclosure **80** is a chamber. The sensors **90** are designed to communicate to a

networked computing environment to supply data to modulate the temperature, humidity, barometric pressure, the air flow or a combination thereof within the enclosure **80**. The heating, cooling and other ventilation systems used to modulate environmental factors such as temperature, humidity, barometric pressure and air flow are controlled by a programmable controller. Optionally, a conveyor system **55** is used to transfer the treated seeds for further processing such as drying. In an embodiment, a fluidized bed dryer **65** for drying the seeds treated with the seed treatment product is shown within the enclosure **80** (FIG. 1). In another embodiment, the fluidized bed dryer **65** is shown to be positioned outside the enclosure **80** (FIG. 2). Other dryers for drying the treated seeds are also contemplated within the scope of this disclosure. In an embodiment, a seed treatment facility includes seed/grain conveyance equipment such as a standard conveyors for providing the bulk seed to the seed treating equipment **30** and also a standard conveyor system **55** for transporting the treated seed for further processing or packaging and distribution to customers.

In the illustrated embodiment shown in FIG. 2, the containers **60** having the seed treatment products are positioned outside the climate controlled enclosure **80**. For example, in certain situations, to conserve space or to reduce the footprint needed for climate control, the containers **60** may be kept outside the enclosure **80**. By maintaining the containers **60** outside the climate controlled enclosure **80**, it may result in improved efficiency in changing the seed treatment product containers without substantially affecting the operating conditions within the enclosure **80**.

In an embodiment, a seed treatment operation system described herein include one or more computers in a networked environment for obtaining and/or processing data from one or more sensors, seed treatment equipment, controllers operating the seed treatment product containers, heating and cooling systems (HVAC) of the environmentally controlled enclosure or chamber and also through user inputs (e.g., through a touch-screen monitor or keyboards). The networked computer can be a personal computer, a server, a router, a workstation, a microprocessor based device or any other processor-based device connected to a remote server or operating environment through cloud storage. Network interface includes wire and/or wireless communication networks such as local-area networks (LAN), wide-area networks (WAN), WiFi networks, and cellular data networks.

Relative humidity (RH) is generally referred to as the ratio of the partial

enclosure is maintained at a different level to simulate the prevailing humidity levels of a target geographical location. For example, in an embodiment, the humidity level of the enclosure for a testing center in a North American location may be set to simulate the high humidity levels of a seed treatment location in Brazil for treating soybeans during the summer season. For example, in an embodiment, the humidity level within the enclosure is maintained at a lower level in a production plant in a high humidity production location, to match the desired humidity level for the chosen seed treatment product or products for the target crop. Further, a specific biological component as part of the seed treatment recipe may require a certain humidity and temperature range for increased survivability of the microorganism present in the biological component.

Suitable ranges of temperature within a climate controlled enclosure or chamber include for example of about 0°C to about 5°C; 5°C to about 10°C; about 10°C to about 15°C; about 15°C to about 20°C; about 20°C to about 25°C; about 30°C to about 35°C; about 25°C to about 30°C; about 35°C to about 40°C; about 40°C to about 45°C; about 15°C to about 17°C; about 17°C to about 20°C; about 22°C to about 24°C; about 25°C to about 28°C; about 21°C to about 23°C; and about 41°C to about 43°C; about 43°C to about 45°C; and any sub-ranges within these exemplified temperature ranges are also suitable. Wider temperature ranges of about plus or minus 10°C are also suitable for operating the enclosure within a desired temperature level. Operational temperature levels in the various geographical regions can range from about 1°C to about 45°C depending on the treating season and location. In an embodiment, preferred temperature ranges are about 50°F to about 70°F (or about 10°C to 22°C). For example, in a production plant, the temperature level maintained within the enclosure is significantly different than the temperature level outside the enclosure, such for example within the building that houses the enclosure. In an embodiment, the temperature level within the enclosure that houses the seed treating equipment is specifically maintained at a predetermined level compared to the temperature level that is maintained in the production plant as a whole. Similarly, in a testing location for evaluating seed treatment formulations, the temperature within the enclosure is maintained at a different level to simulate the prevailing temperature levels of a target geographical location. For example, in an embodiment, the temperature level of the enclosure for a testing center in a North American location may be set to simulate the higher

temperature levels of a seed treatment location in Brazil for treating soybeans during the summer season. For example, in an embodiment, the temperature level within the enclosure is maintained at a lower level in a production plant in a high temperature production location, to match the desired temperature level for the chosen seed treatment product or products for the target crop. Further, a specific biological component as part of the seed treatment recipe may require a certain humidity and temperature range for increased survivability of the microorganism present in the biological component.

One or more microprocessor-based devices are used to obtain and process data from one or more sensors and thereby control the HVAC systems to maintain a desired range of humidity and temperature in the enclosure. Such devices are programmable so that for a certain seed treatment recipe, a particular range of temperature and humidity levels are maintained automatically without specific user input to adjust the individual settings for the temperature and humidity controllers. For example, after a seed treatment recipe and crop type are input into a master computing system (e.g., a computer), the devices that modulate the climate-controlled enclosure will automatically receive instructions from the master computing system to set the temperature and humidity levels that have been previously determined to work optimal for the chosen seed treatment recipe.

In an embodiment, the climate controlled enclosure (e.g., a room or a chamber within a building) maintains a desired level of humidity and temperature independent of the humidity levels that exist inside a seed treatment equipment where the seeds are contacted with a plurality of seed treatment products.

As used herein and in the appended claims, the singular forms "a", "an", and "the" include plural reference unless the context clearly dictates otherwise. Thus, for example, reference to "a plant" includes a plurality of such plants, reference to "a cell" includes one or more cells and equivalents thereof known to those skilled in the art, and so forth.

As used herein, the terms "cultivar" and "variety" refer to a group of similar plants that by structural and/or genetic features and/or performance can be distinguished from other members of the same species.

As used herein, "crop growing environment" generally refers to one or more environmental considerations such as soil moisture, temperature, humidity, pest or disease pressure, day length, soil type, soil nutrient, and any other environmental

factor that has a material impact on the germination and growth of crop plants such as corn, soybean, canola, rice, wheat, cotton, sorghum, barley and others.

The term "effective amount" as used herein as it relates to crop yield or crop vigor refers to an amount of compound effective to increase crop yield or crop vigor.

5 "Crop yield" as defined herein refers to the return of crop material obtained after harvesting a plant crop. An increase in crop yield refers to an increase in crop yield relative to an untreated control crop.

"Crop vigor" refers to rate of growth or biomass accumulation of a crop plant. An "increase in vigor refers" to an increase in growth or biomass accumulation in
10 crop plants relative to an untreated control crop.

As used herein, the phrase "determining the genotype" or "analyzing genotypic variation" or "genotypic analysis" of an individual refers to determining at least a portion of the genetic makeup of an individual and particularly can refer to determining genetic variability in an individual that can be used as an indicator or
15 predictor of a corresponding phenotype. Determining a genotype can comprise determining one or more haplotypes or determining one or more polymorphisms exhibiting linkage disequilibrium to at least one polymorphism or haplotype having genotypic value. Determining the genotype of an individual can also comprise
20 identifying at least one polymorphism of at least one gene and/or at one locus; identifying at least one haplotype of at least one gene and/or at least one locus; or identifying at least one polymorphism unique to at least one haplotype of at least one gene and/or at least one locus. Genotypic variations may also include inserted transgenes or other changes engineered in the host genome.

As used herein, the term "hybrid", when used in the context of a plant, refers
25 to a seed and the plant the seed develops into that results from crossing at least two genetically different plant parents.

As used herein, the term "inbred" refers to a substantially or completely homozygous individual or line. It is noted that the term can refer to individuals or lines that are substantially or completely homozygous throughout their entire
30 genomes or that are substantially or completely homozygous with respect to subsequences of their genomes that are of particular interest.

As used herein, "seed applied component" generally refers to a seed coating material that may include for example, a fungicide or an insecticide or a nematicide or a biological component, or a polymer or a combination of such seed coating

agents. Generally, a coating that is applied exogenously to a seed to promote one or more desirable characteristics of the seed or the seedling or the plant is considered a seed applied component.

As used herein, the terms "trait" and "trait of interest" refer to a phenotype of interest, a gene that contributes to a phenotype of interest, as well as a nucleic acid sequence associated with a gene that contributes to a phenotype of interest. Any trait that would be desirable to screen for or against in subsequent generations can be a trait of interest. Exemplary, non-limiting traits of interest include yield, disease resistance, agronomic traits, abiotic traits, kernel composition (including, but not limited to protein, oil, and/or starch composition), insect resistance, fertility, silage, and morphological traits. In some embodiments, two or more traits of interest are screened for and/or against (either individually or collectively) in progeny individuals.

A propagule (e.g., a seed) can also be coated with a composition comprising a biologically effective amount of a seed applied component. The coatings of the disclosure are capable of effecting a slow release of a desirable compound by diffusion into the seed and surrounding medium. Coatings include dry dusts or powders adhering to the propagule by action of a sticking agent such as methylcellulose or gum arabic. Coatings can also be prepared from suspension concentrates, water-dispersible powders or emulsions that are suspended in water, sprayed on the propagule in a tumbling device and then dried. Formula I compounds that are dissolved in the solvent can be sprayed on the tumbling propagule and the solvent then evaporated. Such compositions preferably include ingredients promoting adhesion of the coating to the propagule. The compositions may also contain surfactants promoting wetting of the propagule. Solvents used must not be phytotoxic to the propagule; generally water is used, but other volatile solvents with low phytotoxicity such as methanol, ethanol, methyl acetate, ethyl acetate, acetone, etc. may be employed alone or in combination. Volatile solvents are those with a normal boiling point less than about 100 °C. Drying must be conducted in a way not to injure the propagule or induce premature germination or sprouting.

All neonicotinoids act as agonists at the nicotinic acetylcholine receptor in the central nervous system of insects. This causes excitation of the nerves and eventual paralysis, which leads to death. Due to the mode of action of neonicotinoids, there is no cross-resistance to conventional insecticide classes such as carbamates,

organophosphates, and pyrethroids. A review of the neonicotinoids is described in Pestology 2003, 27, pp 60-63; Annual Review of Entomology 2003, 48, pp 339-364; and references cited therein.

Neonicotinoids act as acute contact and stomach poisons, combine systemic
 5 properties with relatively low application rates, and are relatively nontoxic to vertebrates. There are many compounds in this group including the pyridylmethyamines such as acetamiprid and thiacloprid; nitromethylenes such as nitenpyram and nithiazine; nitroguanidines such as clothianidin, dinotefuran, imidacloprid and thiamethoxam.

10 There are many known insecticides, acaricides and nematocides as disclosed in The Pesticide Manual 13th Ed. 2003 including those whose mode of action is not yet clearly defined and those which are a single compound class including amidoflumet (S 1955), bifenazate, chlorofenmidine, dieldrin, diofenolan, fenothiocarb, flufenerim (UR-50701), metaldehyde, metaflumizone (BASF-320),
 15 methoxychlor; bactericides such as streptomycin; acaricides such as chinomethionat, chlorobenzilate, cyhexatin, dienochlor, etoxazole, fenbutatin oxide, hexythiazox and propargite.

The weight ratios of a desirable compound (e.g., a diamide) in the mixtures, compositions and methods of the present disclosure are typically from 150:1 to
 20 1:200, preferably from 150:1 to 1:50, more preferably from 50:1 to 1:10 and most preferably from 5:1 to 1:5. Of note are mixtures, compositions and methods wherein component (b) is a compound selected from (b1) neonicotinoids and the weight ratio of component (b) to the compound of Formula 1, an N-oxide, or a salt thereof is from 150:1 to 1:200. Also of note are mixtures, compositions and methods wherein
 25 component (b) is a compound selected from (b2) cholinesterase inhibitors and the weight ratio of component (b) to the compound of Formula 1, an N-oxide, or a salt thereof is from 200:1 to 1:100. Also of note are mixtures, compositions and methods wherein component (b) is a compound selected from (b3) sodium channel modulators and the weight ratio of component (b) to the diamide, an N-oxide, or a
 30 salt thereof is from 100:1 to 1:10.

Table A: Exemplary Seed treatment combination list

Crop/Seed Treatment	Either alone or in combination with or more of the following components
----------------------------	--

Combinations	Insecticide	Fungicide	Other Seed Treatment Components
Corn	Thiamethoxam, Clothianidin, Chlorantraniliprole, Cyantraniliprole, Butenolide, Acetamiprid	Azoxystrobin, Fludioxonil, Mefenoxam, Thiabendazole, Tebuconazol, Penthiopyrad, oxathiapiprolin	Bacillus firmus I-1582, Bacillus subtilis, Bacillus simplex, Abamectin, Polymeric Polyhydroxy Acids
Soybean	Imidacloprid, Thiamethoxam, Chlorantraniliprole, Cyantraniliprole, Butenolide	Metalaxyl, Trifloxystrobin, Penthiopyrad, oxathiapiprolin, Sedaxane, Penflufen, Prothioconazole, Difenoconazole, fluopyram	Bradyrhizobium japonicum, Bacillus firmus I-1582, Bacillus subtilis, Bacillus simplex, Pasteuria nishizawae
Canola	Thiamethoxam, Clothianidin, Chlorantraniliprole, Cyantraniliprole, Butenolide	Metalaxyl, Picoxystrobin, Penthiopyrad, Difenoconazole, Trifloxystrobin, Penflufen, Fludioxonil	Penicillium bilaii,

EXAMPLES

5 The present disclosure is further illustrated in the following Examples. It should be understood that these Examples, while indicating embodiments of the invention, are given by way of illustration only. Thus, various modifications in addition to those shown and described herein will be apparent to those skilled in the art from the foregoing description. Such modifications are also intended to fall within

10 the scope of the appended claims.

EXAMPLE 1

Seed Treatment Evaluations Under Controlled Environments in a Testing Center

15 A seed treatment testing facility was built with a climate-controlled environmental chamber, where the humidity and temperature levels were adjusted to simulate real-world seed treating conditions. An illustration of climate-controlled chamber (also designated as an environmental chamber) is shown in **FIG. 3**. The seeds were sent for treating through a hopper **20**. The seed treatment equipment **30** (a drum treater in this illustrated embodiment) is connected to a plurality of

20 containers **60** that included seed treatment products. This climate-controlled chamber or enclosure **80** contained a seed treating equipment **30** (a drum treater), where a plurality of corn and soybean seeds were treated with a plurality of seed

treatment products that included insecticides, fungicides, and biologicals. An exemplary seed treatment combinations are provided in Table A. The climate-controlled chamber/enclosure **80** also contained a fluidized bed dryer **65** for drying the treated seeds. The humidity and temperature levels were adjusted to evaluate the performance of different formulations of seed treatment products on crop seeds such as corn and soybeans. The appearance of the treated seed, loading analysis, and other performance metrics were evaluated. The environmental chambers and the facility had appropriate dust collection systems and air filter panels.

10

EXAMPLE 2

Seed Treatment Applications under Climate Controlled Conditions in a Production Plant or Retail Location

15

A production facility where seeds for commercial production and distribution to retail customers and growers includes an environmental chamber or a climate-controlled enclosure for treating seeds under predetermined or preselected temperature and humidity levels that appropriate for the chosen seed treatment recipe. In an embodiment, the production facility uses a continuous flow seed treater with the plurality of seed treatment products are pumped into the seed treatment equipment. In an embodiment multiple environmental chambers are used successively to treat the same batch of seeds with a plurality of products that require varying temperature and/or humidity levels. Optionally, when multiple environmental chambers are used, treated seeds from the first environmental chamber may be partially or fully dried prior to treating the same batch of seeds in the second environmental chamber.

25

In an embodiment, the containers having the seed treatment products may be housed within the environmental chambers or they can be stored outside the chambers and optionally at a different environment setting. The treated seeds are conveyed by a suitable conveyor system for further processing, such as, for example, drying in a seed dryer and then for loading, packaging and distribution to a grower customers.

30

A production facility can handle bulk seed treatment of crop seeds including for example, corn, soybean, canola, wheat, sunflower, and alfalfa seeds. Batch seed treaters are also suitable for use within the climate-controlled chambers.

EXAMPLE 3

Developing Seed Treatment Formulations for Certain Environmental Conditions

A seed treatment formulation may perform better under a certain environmental condition (e.g., temperate) versus others (e.g., tropical). It is desirable to evaluate seed treatment formulations under real-world environmental conditions before commercial-level deployment of those formulations for various geographical regions that may have extreme environmental conditions. It is also desirable to evaluate the performance of a seed treatment product under a target environmental condition so that the application rate and any addition of binders/polymers can be optimized for the target environmental condition. In an embodiment, a test formulation for a seed treatment is evaluated under a variety of environmental conditions that are maintained within an environmental chamber that houses the seed treatment equipment. Addition of binders, polymers, colorants, and other parameters such as flow rate, treatment time are adjusted under predetermined ranges of varying humidity and/or temperature levels for a test formulation on a chosen seed type. Evaluation criteria include for example, flowability, plantability, tachyness, seed coating uniformity, dust-off levels, application accuracy of labeled rates and treated seed appearance.

In addition, the treated seeds can also be evaluated for stability, germination rate, bio availability of one or more seed treatment components, biological efficacy of biological components applied to the seeds (e.g., microorganisms or biologically-derived products) under environmental conditions that prevail in a targeted geographical region where the treated seeds will be stored before planting. Such environmental conditions are created within one or more environmental chambers where the temperature and humidity levels are modulated to simulate real-world storage conditions. For example, a North American seed treatment facility can have a plurality of appropriately sized environmental chambers that can maintain different temperature and humidity conditions. In an embodiment, for example, if the treated seeds are planned to be stored in a storage facility for several months, those conditions that occur over the several months within that storage facility are simulated within the chamber to evaluate the performance of the seed applied components as described herein.

CLAIMS

What is claimed is:

1. A method of applying one or more components to a plurality of seeds, the method comprising providing the one or more components and coating the one or more components to the plurality of seeds in a seed treating equipment, wherein the seed treating equipment is housed in an environmentally controlled chamber and wherein the chamber is designed to modulate one or more environmental conditions for a particular seed treatment recipe, the environmental conditions selected from the group consisting of temperature, humidity, barometric pressure, and a combination thereof.
2. A method of controlling humidity and temperature during a seed treatment operation, the method comprising (a) applying one or more seed treatment products to a plurality of seeds wherein the seed treatment application is performed using a seed treatment equipment substantially housed within an environmentally controlled chamber; and (b) controlling the humidity and temperature during the seed treatment operation and wherein the humidity and temperature are set to optimize the seed treatment operation for the seed treatment products.
3. A method of developing a seed treatment product, the method comprising (a) applying one or more test seed treatment formulations to a plurality of seeds wherein the seed treatment application is performed using a seed treatment equipment substantially housed within an environmentally controlled chamber; (b) modulating one or more environmental conditions selected from the group consisting of temperature, humidity, barometric pressure, and a combination thereof during the seed treatment operation; and (c) developing the seed treatment product based on the performance of the test seed treatment formulations in the tested environmental conditions.
4. A method of treating seeds in a production plant with one or more seed treatment products, the method comprising (a) applying the one or more seed treatment products to the seeds in a continuous flow seed treating equipment, wherein the seed treating equipment is substantially housed within an environmentally controlled enclosure and the seed treating equipment handles continuous flow of seeds; and (b) maintaining the temperature and humidity in the enclosure to a previously determined optimal range during the seed treatment application.

5. An environmentally controlled seed treatment system for treating seeds at a production location or a testing location, the system comprising:
- a. a seed treating equipment configured to apply a plurality of seed applied components to a plurality of seeds;
 - 5 b. a climate controlled chamber to substantially enclose the seed treating equipment, wherein the chamber is capable of maintaining a desired range of temperatures and humidity for a particular seed treatment recipe;
 - 10 c. a sensor disposed within the chamber, the sensor selected from the group consisting of temperature, humidity, barometric pressure, air flow sensor and a combination thereof;
 - d. a plurality of containers having the plurality of seed applied components to apply the seed applied components into the seed treating equipment; and
 - 15 e. conveyor system to transfer the plurality of seeds treated with the seed applied components.
6. A method of treating seeds at a seed production facility for delivery of the treated seeds to a customer, the method comprising: providing a seed treatment recipe comprising one or more seed applied components; maintaining appropriate
20 temperature and humidity based on the seed treatment recipe in an area enclosing a seed treatment equipment; and operating the seed treatment equipment to produce treated seeds for the customer.
7. A method of claim 1, wherein the environmental condition is modulated based on previously determined environmental conditions for a geographical
25 location.
8. The method of claim 7, wherein the environmental condition is selected based on the geographical location, timing of application, presence or absence of one or more seed applied components or formulations thereof, type of seeds, seed size, seed shape, volume of seeds being treated, seed treatment rate, nature of the
30 seed treating equipment, volume of the chamber, and a combination thereof.
9. The method of claim 1, wherein the seeds are selected from the group consisting of corn, soybean, canola, rice, wheat, sorghum, sunflower and alfalfa.
10. The method of claim 1, wherein the coating is performed in a continuous flow seed treating equipment.

11. The method of claim 1, wherein the coating is performed in a batch seed treating equipment
12. The method of claim 1, wherein the chamber containing the seed treating equipment is portable.
- 5 13. The method of claim 1, wherein a sensor selected from the group consisting of temperature, humidity, barometric pressure, air flow, and a combination thereof is disposed within the chamber.
14. The method of claim 13, wherein the sensor is not disposed within the seed treating equipment.
- 10 15. The method of claim 2, wherein the treating drum portion of the seed treating equipment is housed within the environmentally controlled chamber.
16. The method of claim 2, wherein the seed treatment products are in containers that are positioned outside the environmentally controlled chamber.
17. The method of claim 3, wherein the environmental conditions are based on
- 15 humidity and temperature values suitable for a geographical region where the seed treatment operation is performed.
18. The method of claim 3, wherein the performance of the test seed treatment formulation is evaluated based on a criteria selected from the group consisting of flowability, plantability, tachyness, seed coating uniformity, dust-off levels,
- 20 application accuracy of labeled rates and treated seed appearance.
19. The method of claim 3, wherein the test formulation is evaluated at a particular humidity level in the chamber, wherein the humidity level is predetermined based on historical humidity levels for a particular geographical region.
20. The method of claim 3, wherein the humidity in the chamber is adjusted
- 25 based on a binder or a polymer used in the seed treatment operation.
21. The method of claim 4, wherein the seeds are selected from the group consisting of corn, soybean, canola, rice, wheat, sunflower and sorghum.
22. The method of claim 4, wherein the seed treatment equipment comprises a portion where the seed treatment products contact the seeds and wherein the
- 30 portion is positioned within the environmentally controlled enclosure.
23. The method of claim 4, wherein the humidity within the enclosure is set based on the seed treatment product.
24. The method of claim 4, wherein the humidity within the enclosure is controlled based on the type of seed that is being treated.

25. The seed treatment system of claim 5, wherein the seed treatment equipment is a continuous flow seed treater.
26. The seed treatment system of claim 5, wherein the seed treatment equipment is an unitized batch treater.
- 5 27. The seed treatment system of claim 5, wherein the seed treatment equipment comprises a drum treater.
28. The seed treatment system of claim 5, wherein the plurality of stations are positioned outside the climate controlled chamber.
29. The seed treatment system of claim 5, wherein plurality of stations include a
10 seed treatment product selected from the group consisting of an insecticide, a fungicide, and a biological component.
30. The method of claim 5, wherein in the sensor is connected to a remote computer network.
31. The method of claim 5, wherein the conveyor system transfers treated seeds
15 to a seed drying station.
32. A method of applying a seed treatment product to a plurality of corn seeds at a production plant, the method comprising:
- a. providing a plurality of corn seeds and one or more seed treatment products;
 - 20 b. contacting the corn seeds with the one or more seed treatment products in a seed treatment equipment, wherein the seed treatment equipment is positioned within a climate controlled enclosure; and
 - c. maintaining an appropriate temperature and humidity in the climate controlled enclosure during the seed treatment application, wherein
25 the temperature and humidity are adjusted based on a prior evaluation with the one or more seed treatment products.
33. The method of claim 32, wherein the corn seeds are hybrid seeds.
34. The method of claim 32, wherein the corn seeds are inbred seeds.
35. The method of claim 32, wherein the corn seeds are transgenic seeds
30 comprising a trait selected from the group consisting of herbicide tolerance, insect resistance, and an agronomic trait.
36. The method of claim 32, wherein the one or more seed treatment products comprise an insecticide selected from the group consisting of thiamethoxam,

clothianidin, chlorantraniliprole, cyantraniliprole, butenolide, acetamprid, sulfoxaflor, and a combination thereof.

37. The method of claim 31, wherein the one or more seed treatment products comprise a fungicide selected from the group consisting of azoxystrobin, fludioxonil, mefenoxam, thiabendazole, tebuconazol, penthiopyrad, oxathiapiprolin, and a combination thereof.

38. A method of increasing crop yield, the method comprising:

- a. treating a plurality of crop seeds with one or more seed treatment products, wherein the treating is performed using a seed treating equipment positioned within a climate controlled enclosure and performed under an optimal environmental condition such that the seed treatment products applied to the seeds are within about -2% to about +2% as compared to the label application rate; and
- b. providing the treated seeds to a crop growing customer for planting in a crop growing environment, thereby increasing the crop yield.

39. The method of claim 37, wherein the seed treatment products applied to the seeds are within about -1% to about +1% or within about -0.5% to about +0.5% of the label application rate.

40. The method of claim 37, wherein the climate controlled enclosure comprises a humidity sensor.

41. The method of claim 37, wherein the climate controlled enclosure is capable of adjusting temperature and humidity based on the type of seed treatment products used.

42. An environmentally controlled seed treatment system at a seed production facility for delivery of treated seeds to a grower, the system comprising:

- a. a seed treating equipment configured to apply a plurality of seed applied components to a plurality of seeds;
- b. a first climate controlled chamber to substantially enclose the seed treating equipment, wherein the chamber maintains a desired range of temperatures and humidity selected based on the seed applied components;
- c. a sensor disposed within the chamber, the sensor selected from the group consisting of temperature, humidity, barometric pressure, air flow sensor, and a combination thereof.

43. The seed treatment system of claim 42, wherein the seed treatment equipment is a continuous flow seed treater.
44. The seed treatment system of claim 42, wherein the seed treatment equipment is an unitized batch treater.
- 5 45. The seed treatment system of claim 42, wherein the seed treatment equipment comprises a drum treater.
46. The seed treatment system of claim 42, wherein the chamber is capable of maintaining a temperature range that is about 10°C to about 22°C when the seed treating equipment is in operation.
- 10 47. The seed treatment system of claim 42, wherein the chamber is capable of maintaining a humidity range that is about 30% to about 40% humidity when the seed treating equipment is in operation.
48. The seed treatment system of claim 42, wherein the chamber is capable of maintaining a temperature range that is equal to or less than 25°C degrees and a
- 15 humidity range that is equal to or less than 50% humidity when the seed treating equipment is in operation.
49. The seed treatment system of claim 42, which comprises both a temperature and a humidity sensor.
50. The seed treatment system of claim 42, which further comprises an air flow
- 20 sensor.
51. The seed treatment system of claim 42, which further comprises a barometric pressure sensor.
52. The seed treatment system of claim 42, further comprising at least one seed treatment product storage station positioned in the first climate controlled chamber.
- 25 53. The seed treatment system of claim 42, further comprising at least one seed treatment product storage station positioned in a second climate controlled chamber located outside the first climate controlled chamber.
54. An environmentally controlled seed treatment system at a seed production facility for delivery of treated seeds to a grower, the system comprising:
- 30 a. a seed treating equipment configured to apply a plurality of seed applied components to a plurality of seeds;
- b. a plurality of climate controlled chambers to substantially enclose the seed treating equipment, wherein the plurality of the chamber are capable of maintaining a plurality of desired ranges of temperatures and humidity;

- c. a sensor disposed within the chamber, the sensor selected from the group consisting of temperature, humidity, barometric pressure, and air flow sensors.
55. A method of evaluating the performance of a seed treatment product under a predetermined environmental condition, the method comprising (a) applying the
5 seed treatment product to a plurality of seeds wherein the seed treatment application is performed using a seed treatment equipment substantially housed within an environmentally controlled chamber; (b) maintaining the predetermined environmental condition selected from the group consisting of temperature, humidity, and barometric pressure during the seed treatment operation, wherein the
10 environmental condition is predetermined based on the environmental condition present in a geographical region; and (c) evaluating the performance of the seed treatment product in the predetermined environmental condition.
56. The method of claim 55, wherein the geographical region is characterized as tropical.
- 15 57. The method of claim 55, wherein the geographical region is characterized as arid.
58. The method of claim 32, wherein the climate controlled enclosure is located at a seed production plant.
59. The method of claim 32, wherein the climate controlled enclosure is portable.
- 20 60. The method of claim 39, wherein the climate controlled enclosure is mounted on one of a trailer and a self-propelled vehicle.
61. The method of claim 32, wherein the climate controlled enclosure is sized to house the seed treatment container.
62. The method of claim 32, wherein the climate controlled enclosure is sized to
25 house the seed treatment products.
63. The method of claim 32, wherein the climate controlled enclosure is sized to house a seed treatment container.
64. The method of claim 32, wherein the climate controlled enclosure maintains the seed treatment equipment at a predetermined temperature.
- 30 65. The method of claim 42, wherein the climate controlled enclosure is located between a source of seed treatment and the seed treatment container, the climate controlled enclosure having a control module to maintain the seed treatment entering the seed treatment container at the predetermined temperature.

66. The method of claim 32, wherein the climate controlled enclosure includes an air conditioner to increase or decrease humidity of air within the seed treatment equipment.
67. The method of claim 32, wherein the climate controlled enclosure includes a
5 sensor to determine an environmental condition.
68. The method of claim 55, wherein the sensor is located within the seed treatment container.
69. The method of claim 55, wherein the sensor is located adjacent to the seed treatment container.
- 10 70. The method of claim 55, wherein the sensor is located adjacent a source of seed treatment.
71. The method of claim 55, wherein the sensor is located within the seed treatment container.
72. The method of claim 55, wherein the sensor is determines one of
15 temperature, humidity, and atmospheric pressure.
73. The method of claim 55, wherein the sensor is connected to a controller.
74. The method of claim 32, wherein the climate controlled enclosure is connected to one of a gas source, a humidifier, a dehumidifier, heat exchanger, and a heater.
- 20 75. The method of claim 32, wherein the climate controlled enclosure is connected to a controller for controlling one of temperature, humidity, and atmospheric pressure within the climate controlled enclosure.
76. The method of claim 75, wherein the controller is connected to a plurality of sensors, the sensors measure one of temperature, humidity, and atmospheric
25 pressure within and outside of the climate controlled enclosure.
77. The method of claim 35 or 55, wherein the step of maintaining includes adjusting one of temperature, humidity, and atmospheric pressure within the climate controlled enclosure based on the difference between the measured one of temperature, humidity, and atmospheric pressure and one of a predetermined
30 temperature, humidity, and atmospheric pressure.
78. The method of claim 52, wherein the controlled enclosure includes a predetermined one of temperature, humidity, and atmospheric pressure level.

79. The method of claim 32, further comprising the step of comparing a measured one of temperature, humidity, and atmospheric pressure with a predetermined one of temperature, humidity, and atmospheric pressure.

80. The method of claim 78, further comprising the step of adjusting one of
5 temperature, humidity, and atmospheric pressure based on a measured one of temperature, humidity, and atmospheric pressure being one of higher or lower than a predetermined one of temperature, humidity, and atmospheric pressure.

81. The method of claim 79, wherein the predetermined one of temperature, humidity, and atmospheric pressure includes a range temperatures, humidity, and
10 atmospheric pressures.

82. The method of claim 32, wherein one of temperature, humidity, and atmospheric pressure within the climate controlled enclosure is adjusted based, in part, on change in a measured one of temperature, humidity, and atmospheric pressure outside of the climate controlled enclosure.

83. The method of claim 55, wherein the controller is connected to one of a gas source, a humidifier, a dehumidifier, heat exchanger, and a heater to one of increase and decrease one of temperature, humidity, and atmospheric pressure within the climate controlled enclosure.

84. The method of claim 32, wherein the climate controlled enclosure is located
20 within a housing to provide a separating barrier between the climate controlled enclosure and external elements.

85. The method of claim 32, wherein a source of seed treatment is located within a housing to provide a separating barrier between the climate controlled enclosure and external elements.

86. The method of claim 32, wherein an intermediate connection between the
25 climate controlled enclosure and a source of seed treatment is located within a housing to provide a separating barrier between intermediate connection and external elements.

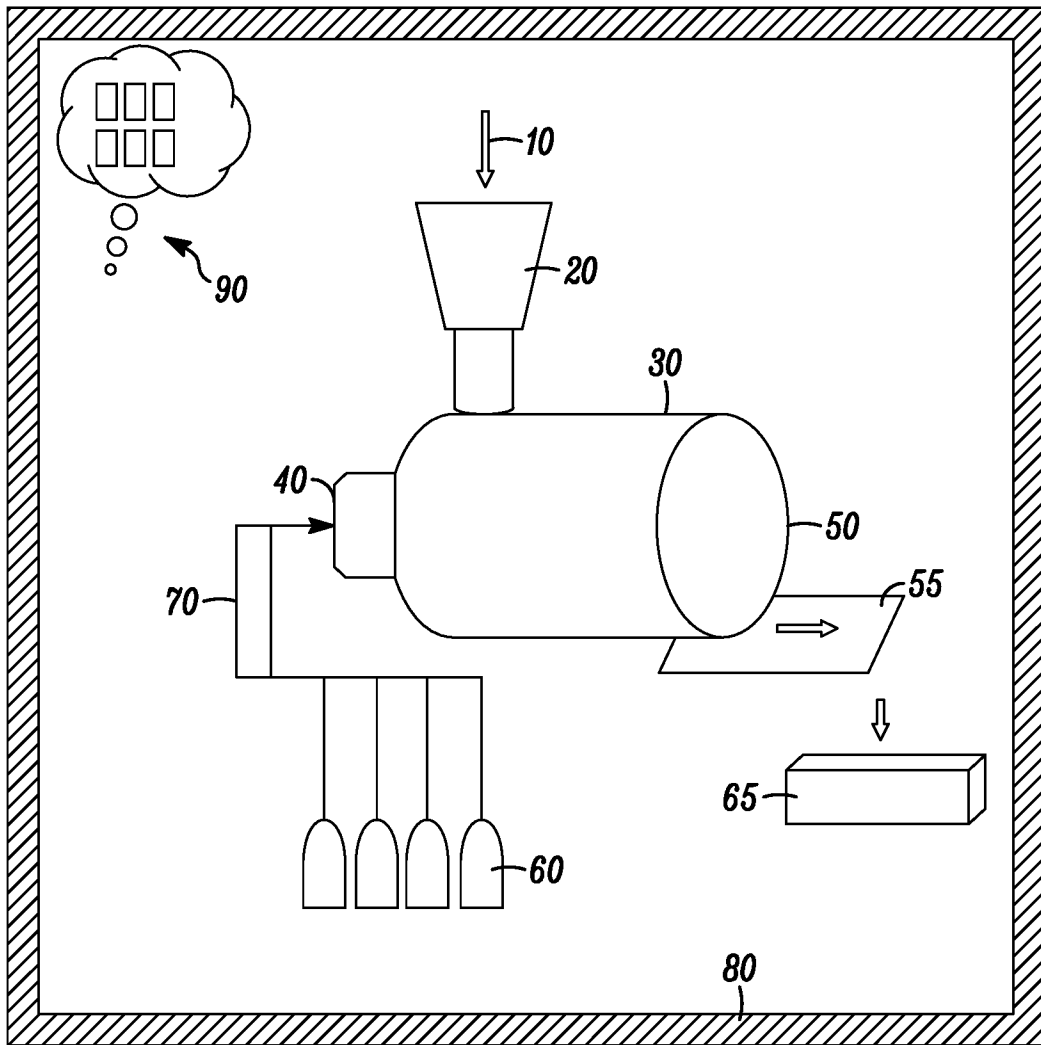

FIG. 1

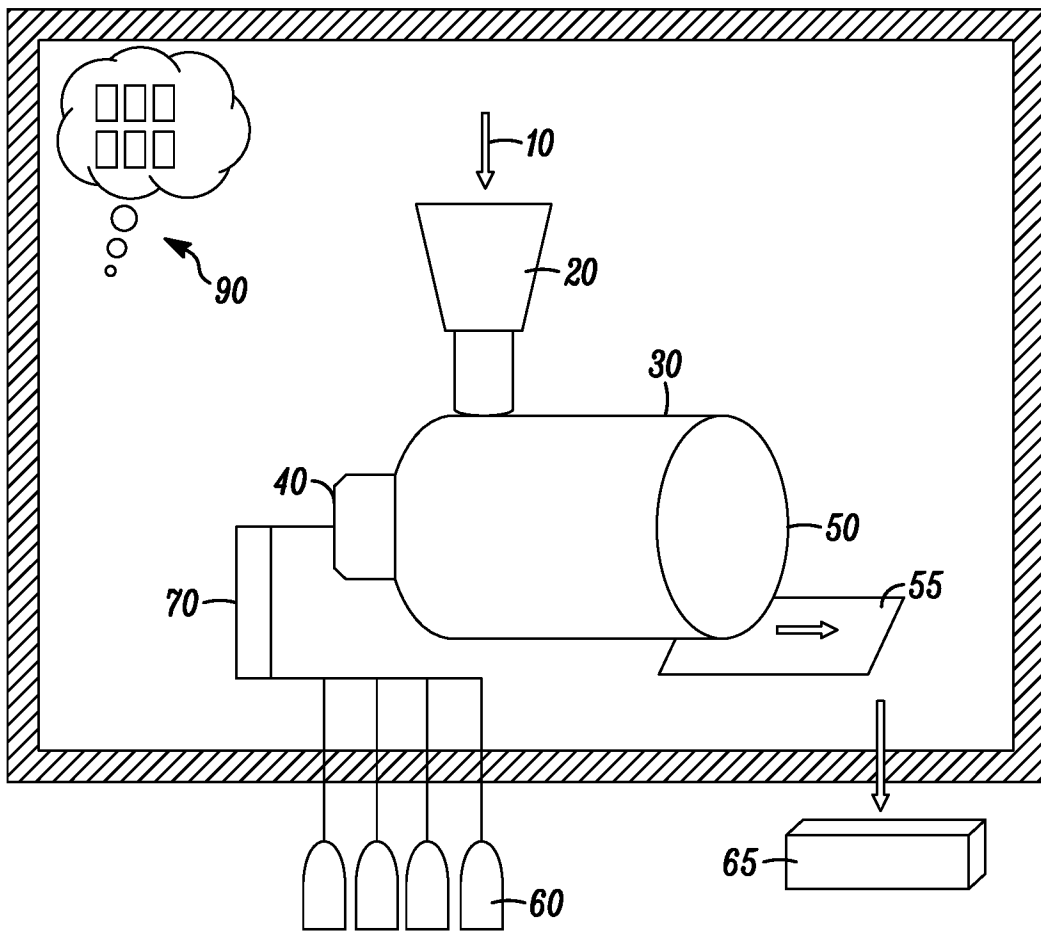

FIG. 2

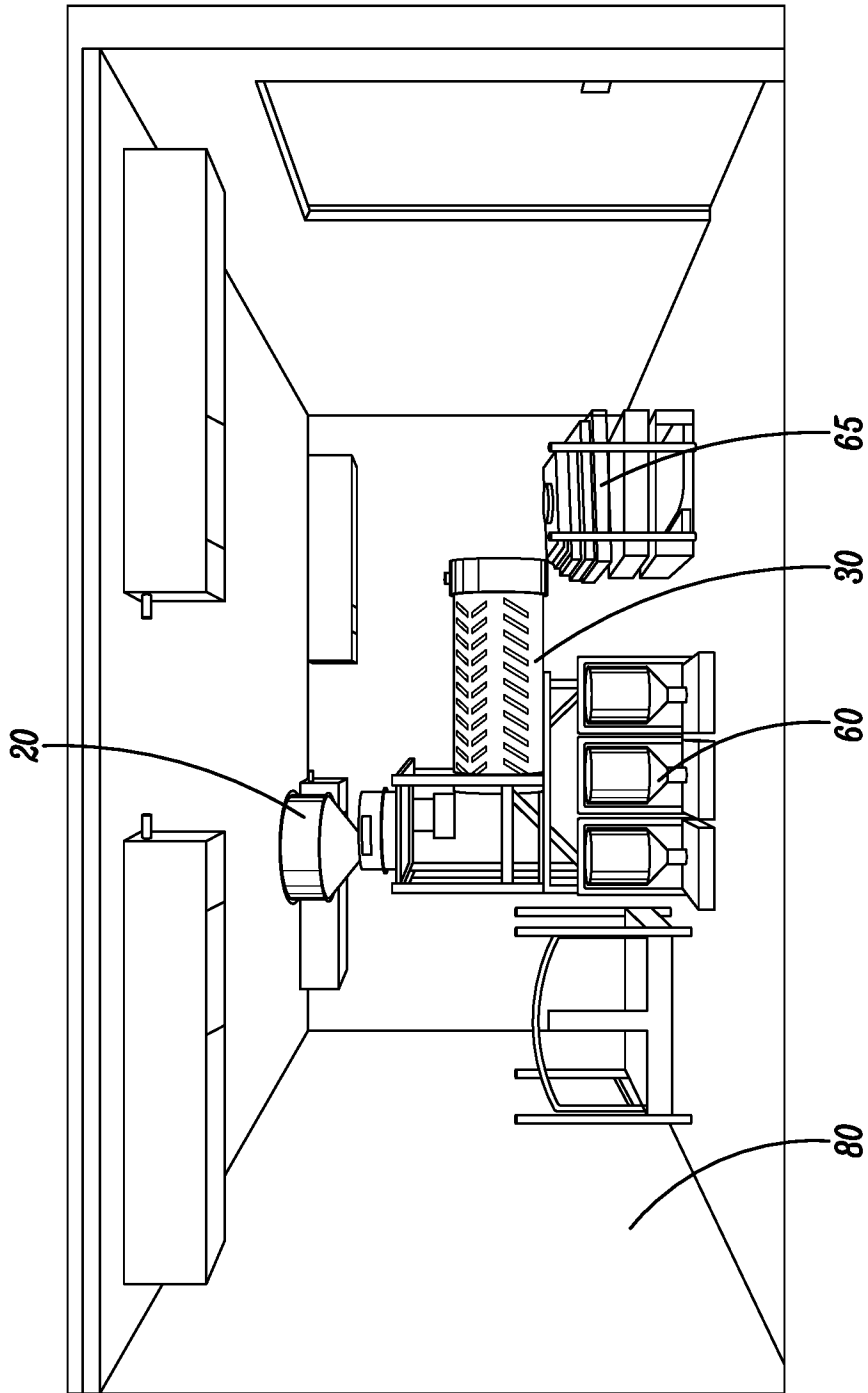

FIG. 3

INTERNATIONAL SEARCH REPORT

International application No.

PCT/US16/48218

Box No. II Observations where certain claims were found unsearchable (Continuation of item 2 of first sheet)

This international search report has not been established in respect of certain claims under Article 17(2)(a) for the following reasons:

1. Claims Nos.:
because they relate to subject matter not required to be searched by this Authority, namely:

2. Claims Nos.:
because they relate to parts of the international application that do not comply with the prescribed requirements to such an extent that no meaningful international search can be carried out, specifically:

3. Claims Nos.:
because they are dependent claims and are not drafted in accordance with the second and third sentences of Rule 6.4(a).

Box No. III Observations where unity of invention is lacking (Continuation of item 3 of first sheet)

This International Searching Authority found multiple inventions in this international application, as follows:

This application contains the following inventions or groups of inventions which are not so linked as to form a single general inventive concept under PCT Rule 13.1. In order for all inventions to be examined, the appropriate additional examination fee must be paid.

Group I: Claims 1-37 and 42-59, 61-86 are directed toward method of applying one or more components to a plurality of seeds, the method comprising providing the one or more components and coating the one or more components to the plurality of seeds in a seed treating equipment, wherein the seed treating equipment is housed in an environmentally controlled chamber and wherein the chamber is designed to modulate one or more environmental conditions for a particular seed treatment recipe, the environmental conditions selected from the group consisting of temperature, humidity, barometric pressure, and a combination thereof.

---Continued Within the Next Supplemental Box---

1. As all required additional search fees were timely paid by the applicant, this international search report covers all searchable claims.
2. As all searchable claims could be searched without effort justifying additional fees, this Authority did not invite payment of additional fees.
3. As only some of the required additional search fees were timely paid by the applicant, this international search report covers only those claims for which fees were paid, specifically claims Nos.:
4. No required additional search fees were timely paid by the applicant. Consequently, this international search report is restricted to the invention first mentioned in the claims; it is covered by claims Nos.:
1-37, 42-86

Remark on Protest

- The additional search fees were accompanied by the applicant's protest and, where applicable, the payment of a protest fee.
- The additional search fees were accompanied by the applicant's protest but the applicable protest fee was not paid within the time limit specified in the invitation.
- No protest accompanied the payment of additional search fees.

INTERNATIONAL SEARCH REPORT

International application No.

PCT/US16/48218

A. CLASSIFICATION OF SUBJECT MATTER IPC(8) - A01C1/00; A01N25/00; A01P3/00, 7/04 (2016.01) CPC - A01C1/00; A01N25/00; Y10S47/09; 47/901; Y02P60/147 According to International Patent Classification (IPC) or to both national classification and IPC		
B. FIELDS SEARCHED Minimum documentation searched (classification system followed by classification symbols) IPC(8) Classification(s): A01C1/00; A01N25/00, 43/00; A01P3/00, 7/04; G06Q10/08 (2016.01) CPC Classification(s): A01C1/00; A01N25/00; A01N43/00; G06Q50/02; Y10S47/09; 47/901; Y02P60/147 Documentation searched other than minimum documentation to the extent that such documents are included in the fields searched Electronic data base consulted during the international search (name of data base and, where practicable, search terms used) PatSeer (US, EP, WO, JP, DE, GB, CN, FR, KR, ES, AU, IN, CA, Other Countries (INPADOC), RU, AT, CH, TH, BR, PH), EBSCO; Google/Google Scholar; ScienceDirect: seed, corn, sorghum, soybean, alfalfa, treater, spray, coat, temperature, humidity, pressure, heat, air, climate, controlled, trailer, vehicle, facility, equipment, chamber, environment, geographic, region, sensor, fungicide, insect, arid, etc.		
C. DOCUMENTS CONSIDERED TO BE RELEVANT		
Category*	Citation of document, with indication, where appropriate, of the relevant passages	Relevant to claim No.
X	US 2013/0273236 A1 (BAYER CROPSCIENCE LP) October 17, 2013; figure 7, paragraphs [0009], [0032], [0042]	1-2, 4, 6, 10-12, 15-16, 22-23 3, 5, 7-9, 12-14, 17-21, 24-37, 42-76, 77/35, 77/55, 78-86
Y	US 2013/0324399 A1 (RIGGS, J et al.) December 5, 2013; paragraphs [0062], [0069], [0078]-[0079]	3, 9, 17-21, 32-37, 58-67, 74-76, 77/35, 79, 81-82, 84-86
Y	EP 0352031 B1 (ECHARTE, P et al.) April 15, 1992; figure 1; page 4, lines 51-55; page 5, lines 33-34; page 6, lines 9-11	5, 13-14, 25-31, 42-54, 68, 71, 84-86
Y	US 2011/0100079 A1 (KAMEI, M) May 5, 2011; paragraphs [0016], [0021]-[0023]	7-8, 17, 19, 24, 47-40, 55-57, 68-73, 77/55, 78, 80, 83
Y	WO 2014/150574 A1 (PIONEER HI-BRED INTERNATIONAL INC.) September 25, 2014; paragraphs [0020], [0024]	31
Y	US 2009/0075325 A1 (DAS, PK et al.) March 19, 2009; figure 2; paragraphs [0051]-[0052]	12, 60
Y	US 2014/0080350 A1 (REINECCIUS, GA et al.) March 27, 2014; paragraph [0087]	51
<input type="checkbox"/> Further documents are listed in the continuation of Box C. <input type="checkbox"/> See patent family annex.		
* Special categories of cited documents: "A" document defining the general state of the art which is not considered to be of particular relevance "E" earlier application or patent but published on or after the international filing date "L" document which may throw doubts on priority claim(s) or which is cited to establish the publication date of another citation or other special reason (as specified) "O" document referring to an oral disclosure, use, exhibition or other means "P" document published prior to the international filing date but later than the priority date claimed "T" later document published after the international filing date or priority date and not in conflict with the application but cited to understand the principle or theory underlying the invention "X" document of particular relevance; the claimed invention cannot be considered novel or cannot be considered to involve an inventive step when the document is taken alone "Y" document of particular relevance; the claimed invention cannot be considered to involve an inventive step when the document is combined with one or more other such documents, such combination being obvious to a person skilled in the art "&" document member of the same patent family		
Date of the actual completion of the international search		Date of mailing of the international search report
7 December 2016 (07.12.2016)		19 JAN 2017
Name and mailing address of the ISA/US Mail Stop PCT, Attn: ISA/US, Commissioner for Patents P.O. Box 1450, Alexandria, Virginia 22313-1450 Facsimile No. 571-273-8300		Authorized officer Shane Thomas PCT Helpdesk: 571-272-4300 PCT OSP: 571-272-7774

INTERNATIONAL SEARCH REPORT
Information on patent family members

International application No.

PCT/US16/48218

-***-Continued from Box No. III Observations where unity of invention is lacking (Continuation of item 3 of first sheet) -***-

Group II: Claims 38-41 and 60 are directed toward a method of increasing crop yield, the method comprising a. treating a plurality of crop seeds with one or more seed treatment products, wherein the treating is performed using a seed treating equipment positioned within a climate controlled enclosure and performed under an optimal environmental condition such that the seed treatment products applied to the seeds are within about -2% to about +2% as compared to the label application rate; and b. providing the treated seeds to a crop growing customer for planting in a crop growing environment, thereby increasing the crop yield.

The inventions listed as Groups I and II do not relate to a single general inventive concept under PCT Rule 13.1 because, under PCT Rule 13.2, they lack the same or corresponding special technical features. Group I has at least the seed treating equipment is housed in an environmentally controlled chamber and wherein the chamber is designed to modulate one or more environmental conditions for a particular seed treatment recipe, the environmental conditions selected from the group consisting of temperature, humidity, barometric pressure, and a combination thereof that Group II does not have. Group II has at least treating is performed under an optimal environmental condition such that the seed treatment products applied to the seeds are within about -2% to about +2% as compared to the label application rate; and b. providing the treated seeds to a crop growing customer for planting in a crop growing environment, thereby increasing the crop yield that Group I does not have.

The common technical features of Groups I and II are at least treating a plurality of seeds with one or more seed treatment products, wherein the treating is performed using a seed treating equipment positioned within a climate controlled enclosure. These common features are disclosed by US 2013/0273236 A1 to BAYER CROPSCIENCE LP (hereinafter 'Bayer'). Bayer discloses a treating a plurality of seeds with one or more seed treatment products (treating seeds with treatment fluid, paragraph [0007]), wherein the treating is performed using a seed treating equipment positioned within a climate controlled enclosure (seed treatment container 18 with liquid dispersion portion 80 to disperse treatment fluid within treatment container 18, wherein heated or unheated air may be introduced into treatment container 18 (climate controlled enclosure), figures 1A, 1B, 2, and 3B, paragraphs [0036] and 0041).

Since the common technical feature is previously disclosed by the Bayer reference, these common features are not special and so Groups I and II lack unity.