

(No Model.)

G. WEBSTER.
INSULATOR FOR ELECTRIC CONDUCTORS.

No. 526,472.

Patented Sept. 25, 1894.

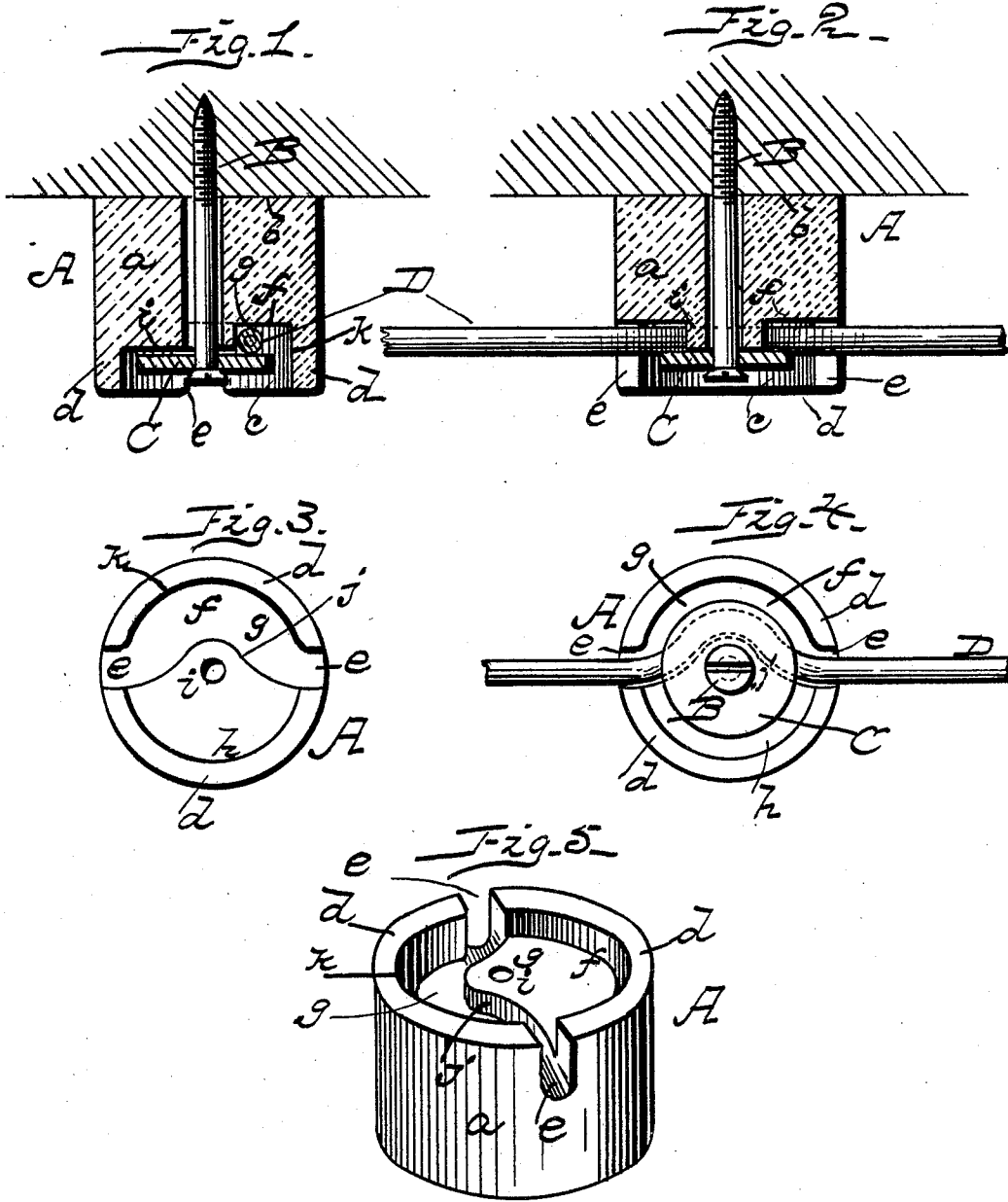

WITNESSES
Jas. B. Clarke
M. M. Mason

INVENTOR—
George Webster.
By C. H. Bates Attorney

UNITED STATES PATENT OFFICE.

GEORGE WEBSTER, OF PHILADELPHIA, PENNSYLVANIA, ASSIGNOR OF ONE-HALF TO ARTHUR J. INGRAHAM, OF SAME PLACE, AND SAMUEL H. BROWN, OF BALA, PENNSYLVANIA.

INSULATOR FOR ELECTRIC CONDUCTORS.

SPECIFICATION forming part of Letters Patent No. 526,472, dated September 25, 1894.

Application filed July 26, 1894. Serial No. 518,675. (No model.)

To all whom it may concern:

Be it known that I, GEORGE WEBSTER, a citizen of the United States, residing at Philadelphia, in the county of Philadelphia and State of Pennsylvania, have invented certain new and useful Improvements in Insulators for Electric Conductors; and I do hereby declare the following to be a full, clear, and exact description of the invention, such as will enable others skilled in the art to which it appertains to make and use the same.

This invention has relation to improvements in hangers or insulators for electric conductors and it consists in the novel construction, combination, and arrangement of the same, all as will be hereinafter fully described.

The annexed drawings to which reference is made, fully illustrate my invention, in which—

Figure 1, represents a vertical transverse sectional view of my device. Fig. 2, is a longitudinal vertical sectional view of the same. Fig. 3 is a plan view; the washer, screw and conductor, removed. Fig. 4 is a plan view; washer, screw and conductor attached—and Fig. 5, is a perspective view; washer, screw and conductor removed.

Referring by letter to the accompanying drawings, A designates the electric conductor hanger or insulator and B, is a screw passing centrally through the same.

C, indicates a holder or washer and D, is the conductor, which parts are combined to operate together.

The hanger A, is constructed of non-conducting material, preferably porcelain and is composed of the body portion *a* having the flat solid part *b* which rests upon the support, ceiling or other place the hanger may be applied. The opposite end of this hanger is recessed as at *c* providing semi-circular flanges or rims *d*, which are separated by two notches or kerfs *e, e*, that are in a horizontal line with the central line of the hanger. To one side of the center of this recess, the same is made deeper than the other side, as at *f*, providing a seat *g* for the electric conductor D, while the opposite half or portion *h* of said recess is shallow presenting a raised and flat portion

i, which is centrally perforated, said perforation extending entirely through the hanger. This raised portion in the recess of the hanger provides a curved shoulder *j* which extends from one of the kerfs to the opposite kerf and in connection with the opposite wall *k* of the interior of the recess in said hanger, provides an indirect bed or passage from one kerf to the opposite kerf as shown in Figs. 3, 4, and 5 of the drawings.

In combination with the hanger, thus described, I use an ordinary screw (but any similar device may be used instead) for securing the hanger to a wall, ceiling or other support, and a washer C to be secured upon the screw and forced up against the floor of the shallow recess of the hanger. This washer C is constructed of fiber or other non-conducting material and when screwed in place, one half of it extends over the deep recess, thereby confining the conductor between the same and the floor of the hanger, while the opposite portion of the washer has its flat bearing upon the floor of the shallow recess portion.

Thus it will be seen by my construction of a hanger for electric conductors, that the kerfs are in a central line on each side of the screw, the side walls of said kerfs being straight and parallel and that when the conductor is inserted between the washer and floor of the deep recess it has an indirect passage or takes a serpentine course from one kerf to the other while the remaining portion of the conductor presents a straight line on each side of the hanger, and the screw that secures the hanger to a support also serves to secure the washer, which clamps the conductor, in place; the screw being entirely insulated, and an insulator as herein shown and described, is durable, easily and quickly attached to a conductor, ornamental as well as cheap to manufacture.

Having thus described my invention, what I claim, and desire to secure by Letters Patent, is—

1. An insulator having a perforation through its entire body a deep and shallow recess adjacent to one another, in its face, the deep recess forming a channel, the opposite

ends, terminating in kerfs formed in the wall of the recesses, and means for securing the electric conductor therein substantially as described.

5 2. An insulator for electric conductors having a recess in its face; one half of this recess being deeper than the other half, the deepest half forming an indirect channel from one side of said insulator to the other, and means for securing an electric conductor
10 in this channel, substantially as described.

3. An insulator for electric conductors having a recess in its face of different depths, and kerfs in the walls of the recess opposite

to one another the walls of said kerfs being parallel to one another; a central opening therein a screw adapted to pass within said opening for securing the insulator to a support and a washer secured to said screw composed of non-conducting material all substantially as described. 15 20

In testimony whereof I affix my signature in presence of two witnesses.

GEORGE WEBSTER.

Witnesses:

WM. L. BOGGS,

A. J. INGRAHAM.