



US00D433353S

United States Patent [19]

[11] Patent Number: Des. 433,353

Wu et al.

[45] Date of Patent: ** Nov. 7, 2000

[54] MOTOR VEHICLE

D. 327,457	6/1992	Saito	D12/107
D. 330,694	11/1992	Kimura et al.	D12/107
D. 412,464	8/1999	Ichihara et al.	D12/107

[75] Inventors: **Shih-Chang Wu; Julian Lao**, both of Tainan Hsien, Taiwan

[73] Assignee: **E-Ton Dynamics Technology Industry**, Tainan Hsein, Taiwan

Primary Examiner—Melody N. Brown
Attorney, Agent, or Firm—Dickinson Wright PLLC

[**] Term: **14 Years**

[57] CLAIM

[21] Appl. No.: **29/110,530**

The ornamental design for a motor vehicle, as shown and described.

[22] Filed: **Sep. 9, 1999**

DESCRIPTION

[51] LOC (7) Cl. **12-11**

FIG. 1 is a perspective view of motor vehicle showing my new design;

[52] U.S. Cl. **D12/107**

FIG. 2 is a front elevational view thereof;

[58] Field of Search D12/107, 3; 120/233, 120/311, 312, 225, 229, 315

FIG. 3 is a rear elevational view thereof;

FIG. 4 is a left side elevational view thereof;

FIG. 5 is a right side elevational view thereof; and,

FIG. 6 is a top plan view thereof.

[56] References Cited

U.S. PATENT DOCUMENTS

D. 299,707 2/1989 Makita et al. D12/107

1 Claim, 6 Drawing Sheets

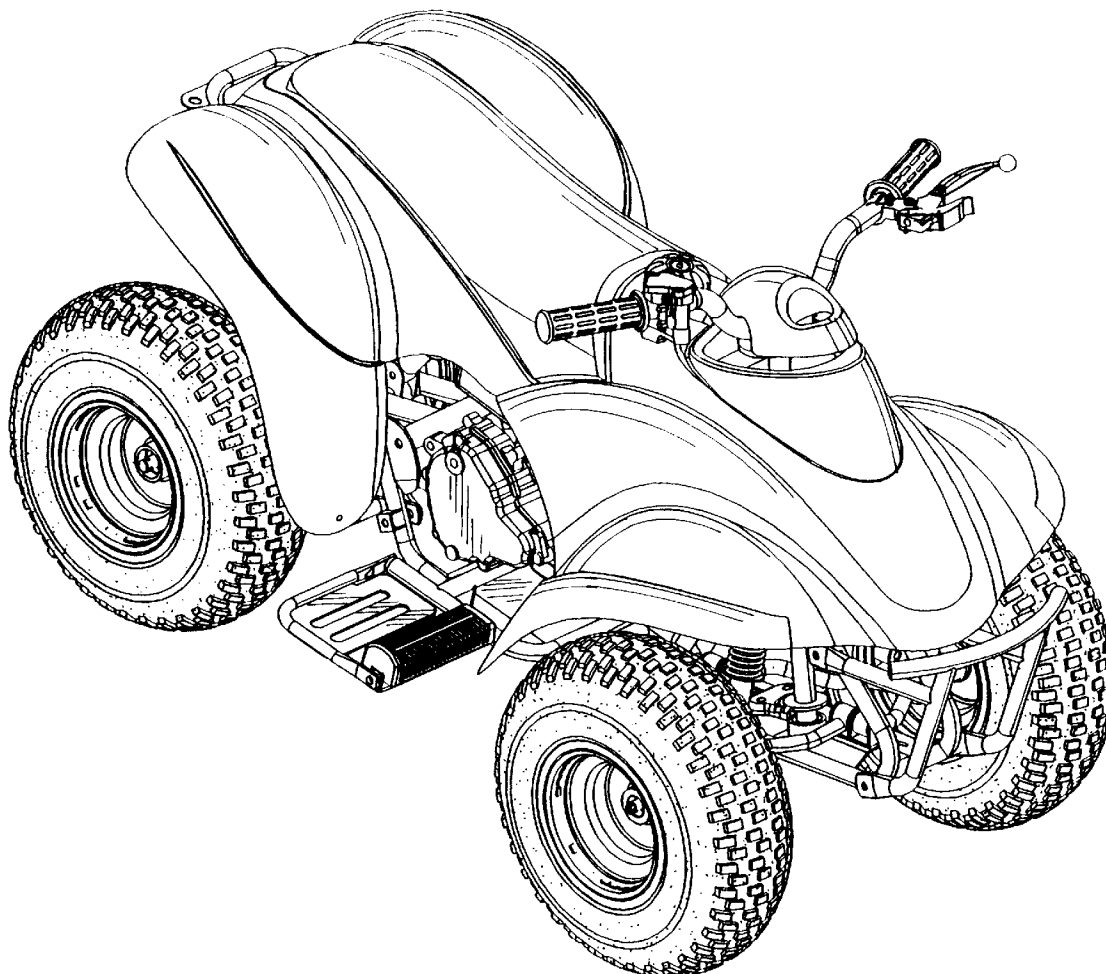

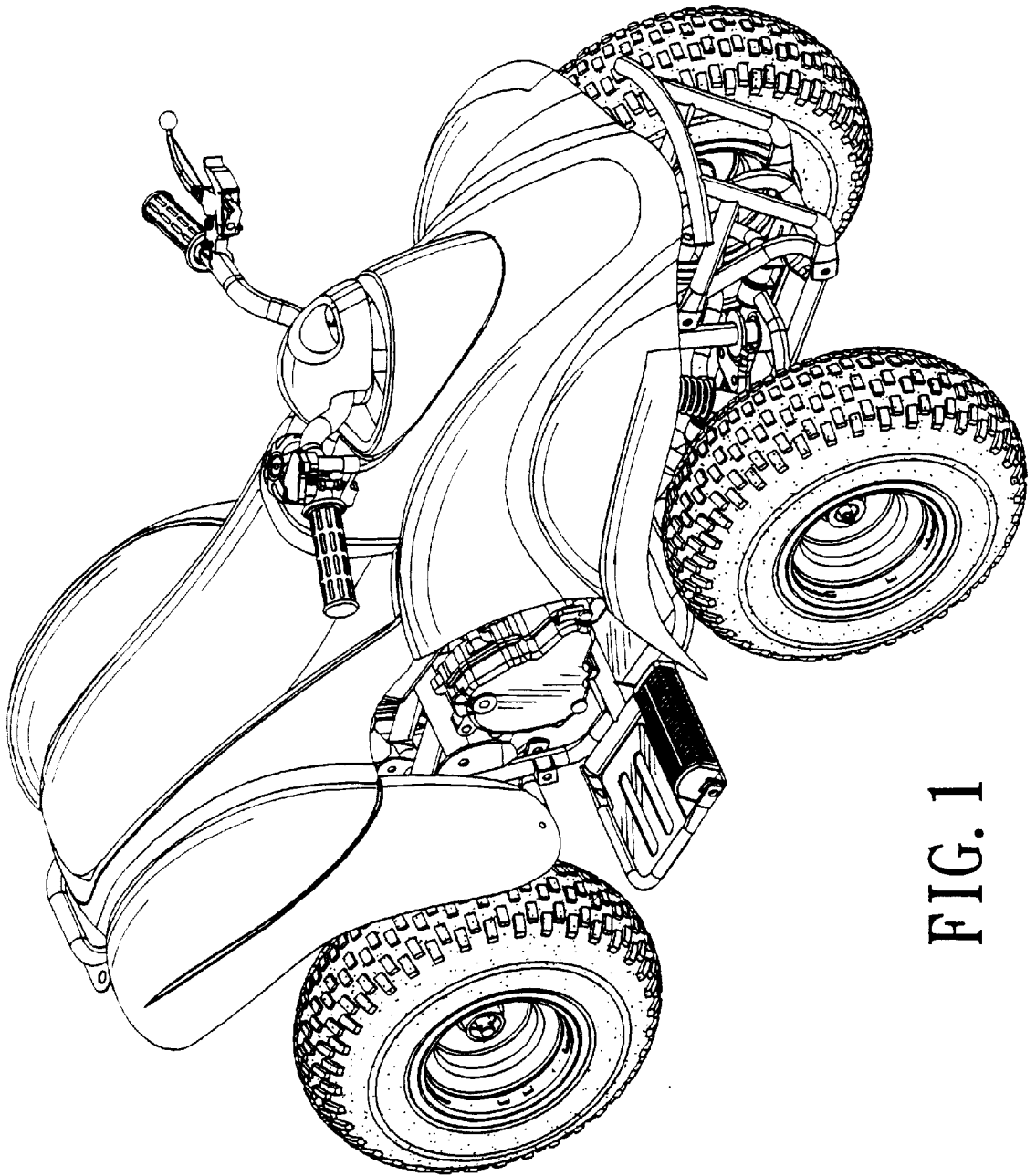

FIG. 1

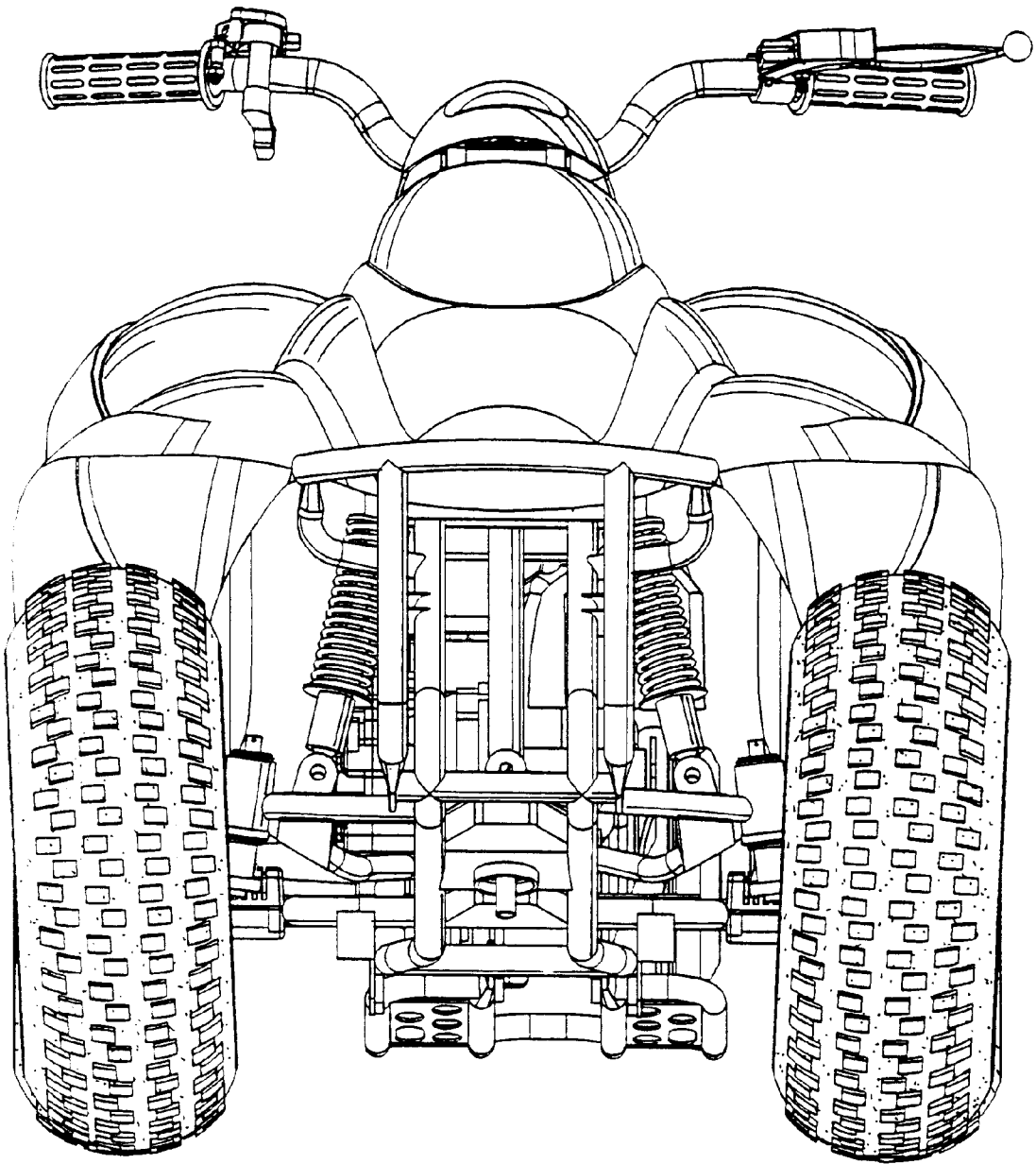

FIG. 2

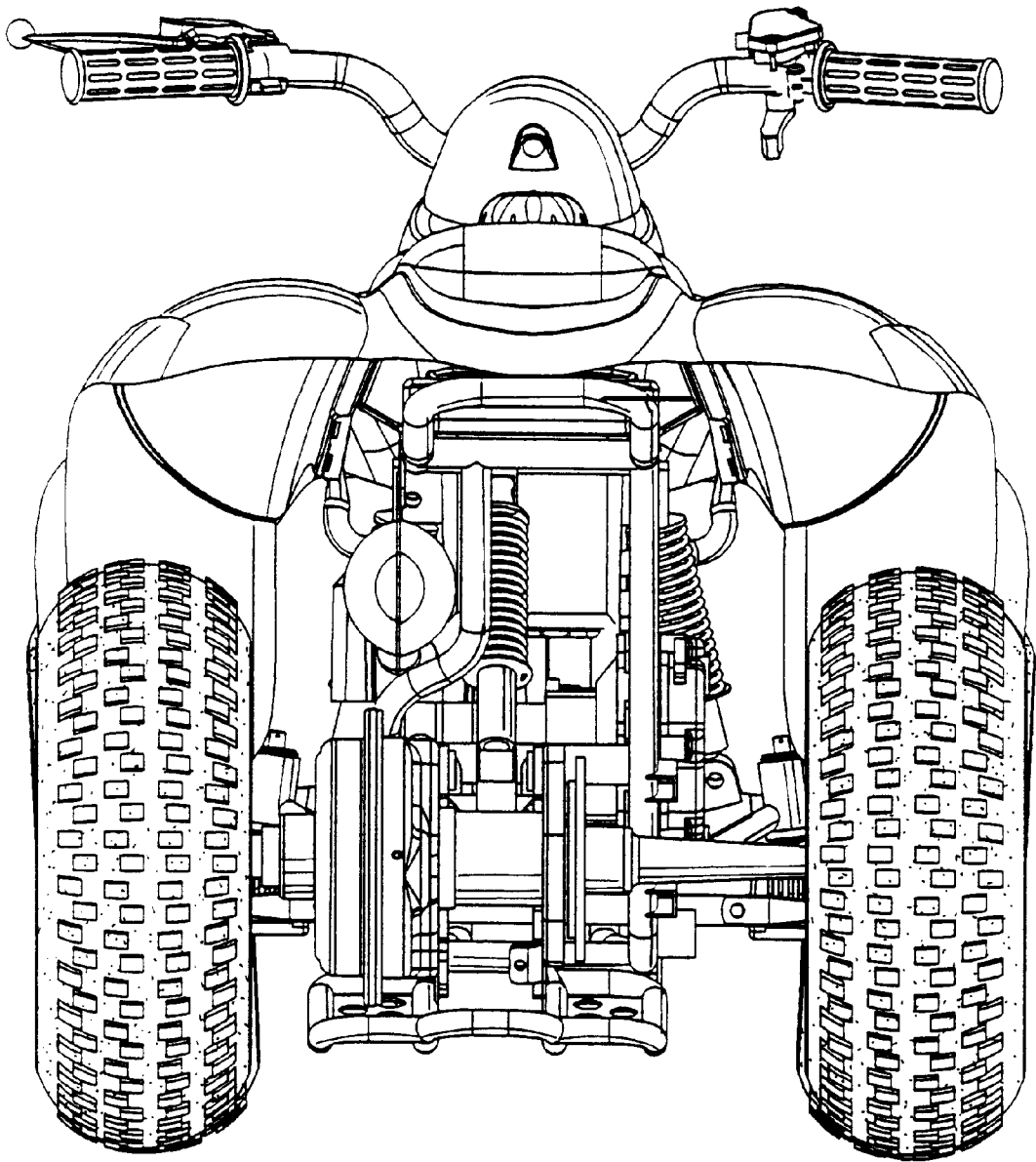

FIG. 3

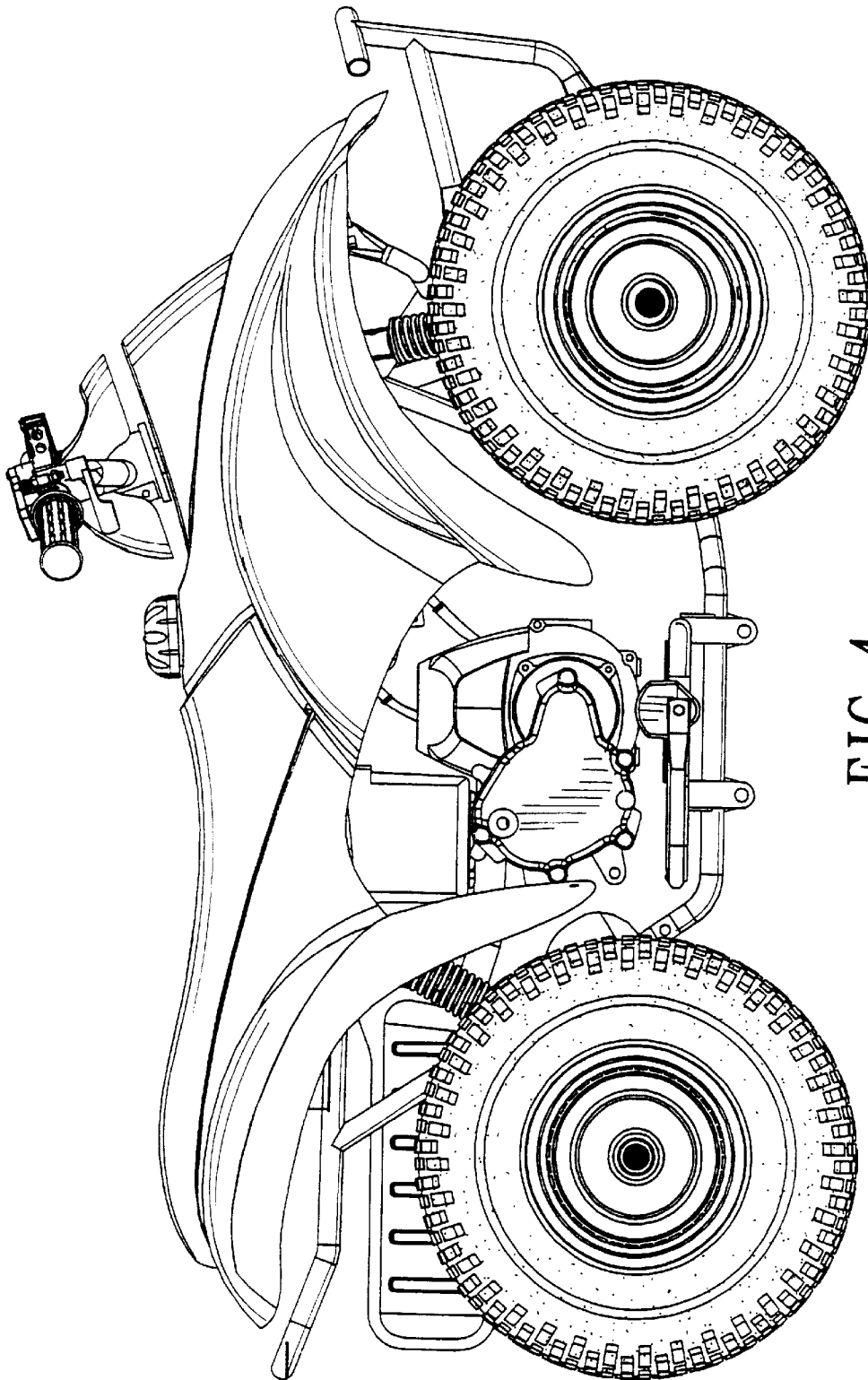

FIG. 4

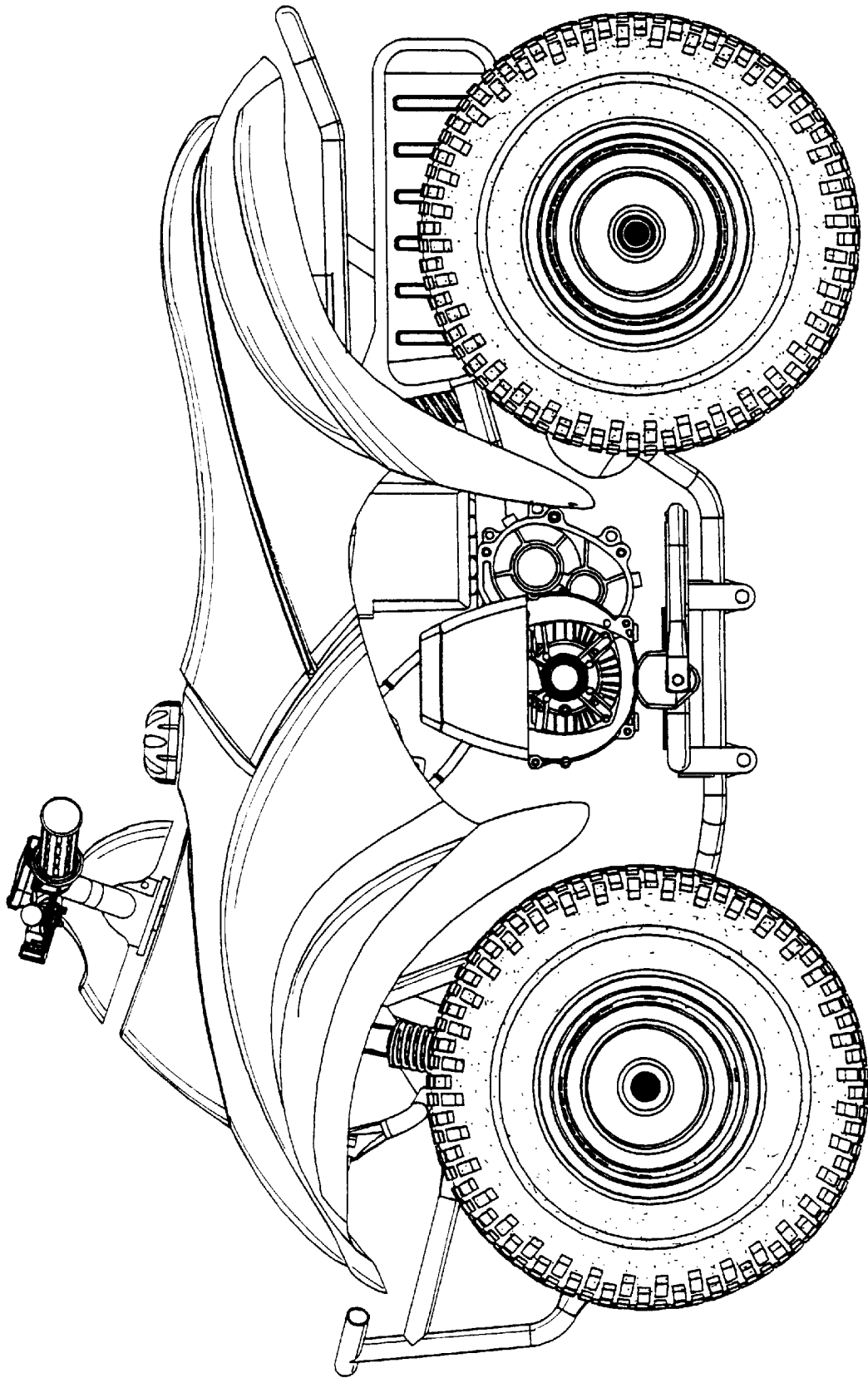

FIG. 5

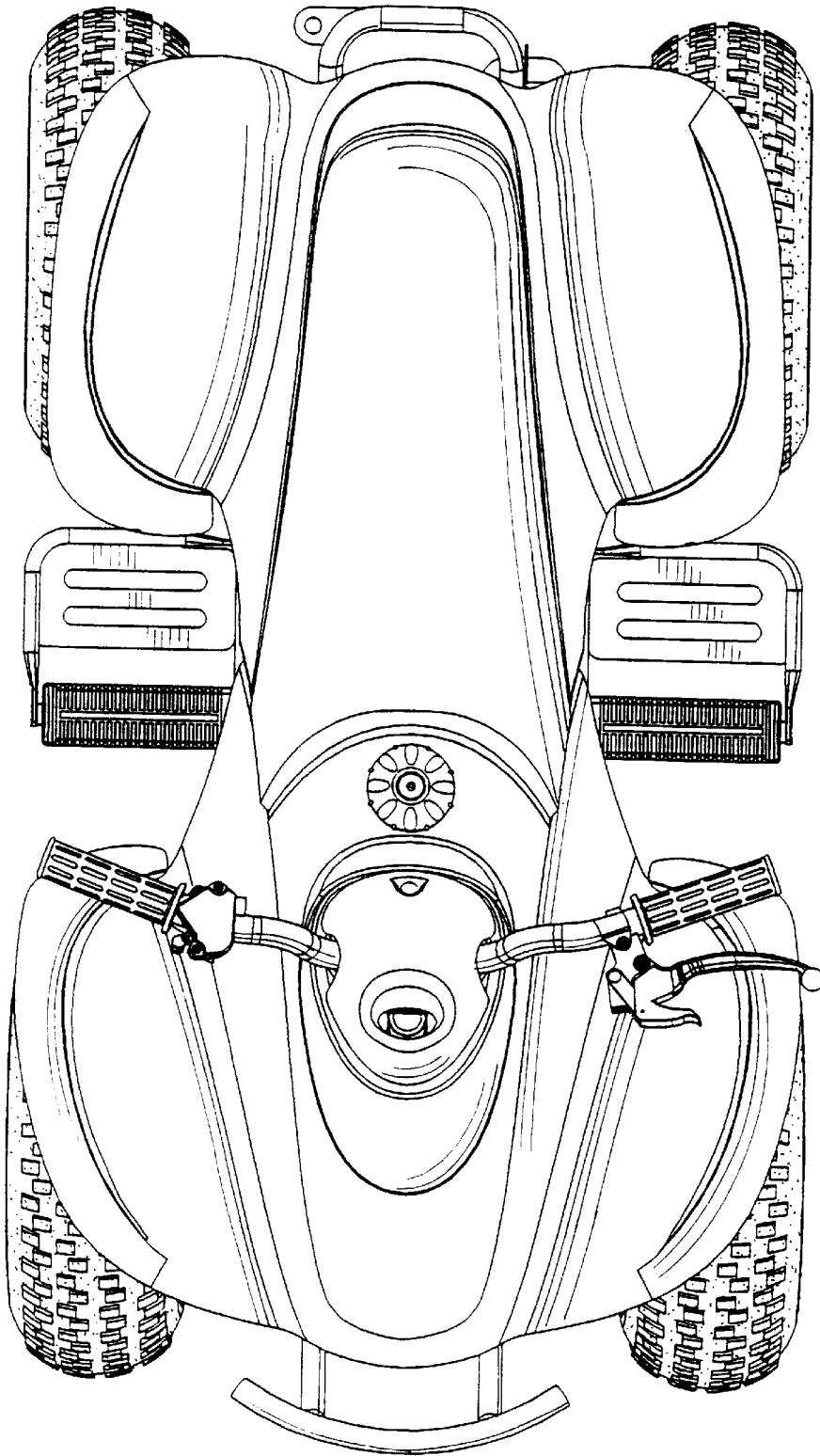

FIG. 6