



Europäisches Patentamt  
European Patent Office  
Office européen des brevets



(11) EP 0 917 125 A1

(12) EUROPEAN PATENT APPLICATION

(43) Date of publication: 19.05.1999 Bulletin 1999/20 (51) Int. Cl.<sup>6</sup>: G09F 9/35

(21) Application number: 97830589.4

(22) Date of filing: 11.11.1997

(84) Designated Contracting States:  
AT BE CH DE DK ES FI FR GB GR IE IT LI LU MC  
NL PT SE  
Designated Extension States:  
AL LT LV MK RO SI

(72) Inventors:  
• Monterisi, Carlo  
21100 Varese (IT)  
• Crespi, Piercarlo  
21040 Venegono Inferiore (IT)

(71) Applicant: SYNCO ITALIANA S.r.l.  
21040 Vedano Olona (IT)

(74) Representative:  
Pellegrini, Alberto et al  
c/o Società Italiana Brevetti S.p.A.  
Via Puccini, 7  
21100 Varese (IT)

(54) Visual communication system with LCD pricetags updatable by remote control

(57) Updatable price tags especially for use on edible goods have an alphanumeric liquid crystal display (LCD) and a battery powered receiver and drive circuits. The information displayed may be organized and updated through a hand held battery powered remote control provided with a keyboard for entering the information (unit price).

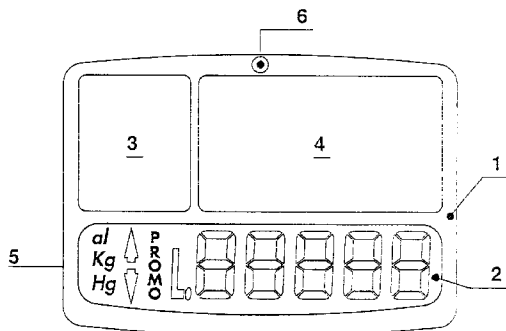

FIG. 1

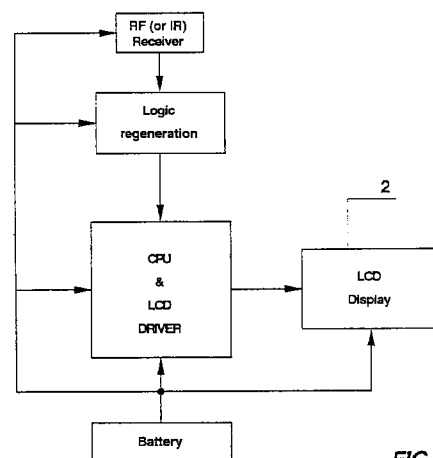

FIG. 2

EP 0 917 125 A1

## Description

[0001] The present invention relates to visual communication systems using updatable price tags for goods displayed in retail sale shops.

[0002] In shops, supermarkets and similar points of sale where goods and products for sale are displayed together with their relative price, it is common to employ price tags that may be easily updatable to avoid the need of reprinting the price tags or labels.

[0003] In particular, in case of edible products, the use of updatable price tags, composable by rearrangement of a plurality of preprinted alphanumeric cards is widespread for readily updating the price of goods on sale manually. Price tags are commonly supported by pins, stands or other card holding devices that may be placed directly on meat cuts, forms of cheese, small goods, precooked foods and the like.

[0004] The manual updating of the displayed price, even if done with such helpful implements, remains a time consuming and laborious operation because of the large number of price tags to update often daily or just about so frequently.

[0005] Moreover, the frequent handling of these price tags, often held in place by special clips or hooks located on their rear side and engaging with the upper end, pins stuck in edible products, imposes periodic washing and disinfecting treatments of the price tags and supporting components. The possibility of manually updating the displayed prices without the need to handle the price tags would be a great advantage in terms of a quicker and easier updating while improving cleanliness conditions.

[0006] To these needs offer an effective response the present invention, according to which all the price tags, rather than employing preprinted alphanumeric cards, are furnished with an alphanumeric liquid crystal display to show the price of the goods.

[0007] Essentially, the price marking system is characterized in that each updatable price tag has an alphanumeric liquid crystal display, a circuitry comprising a receiver of electromagnetic signals, a circuit coupled to said receiver converting the decoded or demodulated signals received into logic signals, a processing circuit of said logic signals controlling a driving stage of the liquid crystals displays and a power supply battery.

[0008] Setting and updating of the displayed price is made by the use of a battery powered remote control, equipped with a keyboard to key in the updating information, a processing circuit of the signals produced through the keyboard, and a transmitter stage of electromagnetic signals modulated by the signals as processed by said processing circuit.

[0009] Preferably, the updating remote control itself is furnished with an alphanumeric liquid crystals display showing the data set through the keyboard.

[0010] The carrier signal may be a radio frequency (RF) signal, or an optic signal for example of wavelength

in the infrared range (IR).

[0011] In practice the price setting-updating remote control may be structured in general terms like a familiar remote control of a TV or HF apparatus, with the due differences, while each battery powered price tag incorporates the receiving, decoding and processing circuits that control the setting-updating of the relative alphanumeric liquid crystal display (LCD.)

Figures 1 and 2 show respectively the exterior appearance and a functional block diagram of each battery powered price tag of the system of the invention, according to an embodiment thereof.

Figures 3 and 4 show respectively the exterior appearance and a functional block diagram of a battery powered remote control of the system.

[0012] By referring to Fig. 1, each battery powered price tag of the system of the present invention can be realized even with a different exterior appearance from that the sample shown.

[0013] Essentially, each price tag 1 is equipped with an alphanumeric liquid crystals display 2 of six or more figures, to permit the updating of both the currency and the price, as well as of an eventual reference to the weight or items number.

[0014] The price tag may be conveniently furnished with one or more transparent pockets 3 and 4, into which may be inserted, in a conventional manner, one or more printed labels or cards for showing specifications, provenience and other details of the good and/or promotional messages.

[0015] The body of the price tag 1 is essentially a box 5 of molded plastic material, sealably closed in a substantially permanent manner in order to prevent infiltration of fluids, juices, washing solutions, disinfecting liquids, and the like.

[0016] On the back of the box 5 of the price tag there will be a hatch for accessing the battery compartment for a periodic substitution of the powering battery.

[0017] Depending on the type of the electromagnetic signals receivable from the price tag receiver, there may be on the front side of the same a "window" transparent to the electromagnetic signals 6, for example of infrared wavelength.

[0018] Of course, when the electromagnetic signals are radio frequency (RF) signals, the body of molded plastic material of the price tag is in itself perfectly transparent to such signals and it will not be necessary the presence of any "window" 6, but the circuitry within the box like body 5 will be perfectly suitable to receive the RF signals.

[0019] The scheme of the internal circuitry of each price tag receiver is shown by way of a block diagram in Fig. 2.

[0020] The block RECEIVER detects and demodulates the electromagnetic signals destined to it, and beside a specific transducer, for example a RF signals

antenna or a phototransistor or photodiode in case of (IR) signals, the block includes converter circuits that may be of the heterodyne type as in a common radio receiver or of a different type depending on the nature of the signals employed for the transmission via ether as well as detecting and demodulating circuits and circuits for amplifying the signals received.

[0021] The demodulated or detected signals, properly amplified are converted in logic signals by the LOGIC REGENERATION block, so that they can be processed by a logic processing block that can incorporate a microprocessor and a driving stage of the alphanumeric liquid crystals display of the price tag (CPU & LCD DRIVER)

[0022] A rechargeable or periodically replaceable battery powers all the circuit blocks as well as the LCD DISPLAY

[0023] Fig. 3 shows the external appearance of a remote control for setting the visual communication implements of the system of the present invention.

[0024] According to a preferred embodiment, the remote control T is also furnished with an LCD display which is useful for the operator to set and check the data that are thereafter transmitted upon an enter command to an updatable price tag of Figures 1 and 2.

[0025] The remote control is furnished with an essential keyboard for composing the alphanumeric price string as well as any other updatable data to be displayed on the price tag.

[0026] The basic scheme of the remote-control/transmitter unit is shown by way of a block diagram in Fig. 4.

[0027] The keyboard constitutes the input device of the data that are then processed by the CPU & LCD DRIVER, that may include a microprocessor and driving circuits for the alphanumeric liquid crystals display, reproducing on the display the set alphanumeric string. The set data signals are eventually sent to the RF or IR TRANSMITTER.

[0028] The same digital data that drive the LCD display constitute in fact the modulating signals that are eventually sent to the transmitter block, which may contain conventionally a carrier wavelength generating circuit, a modulating stage of the carrier frequency or of the carrier wavelength in function of the digital signals received from the processing circuitry, and a power stage driving a transmission antenna for a modulated RF signal or optical device for emitting a modulated IR signal.

[0029] Preferably the modulation of the carrier frequency is of a digital type, realized for example in a pulse width modulation (PWM) mode which is relatively simple to implement and particularly reliable, though any other method of modulation may be alternatively used.

[0030] If an RF carrier signal is used, both the antenna A of the transmitter and the receiving antenna inside the price tags will be highly directional in order to facilitate the one-by-one updating, in an essentially independent

way of a plurality of price tags that often may be disposed necessarily close to each other.

[0031] Obviously, if the electromagnetic signals are optical or IR signals, the directionality would be relatively intrinsic and eventually increased by lenses and/or diaphragms in either the transmitter and/or the receiver, thus requiring an alignment of the two during the transfer of the updated data, set on the remote control and eventually transmitted to the receiver price tag by a transmission command.

[0032] In practice the system of visual communication of the present invention may be implemented in different ways or embodiments similarly to the remote control of TV sets and the like.

[0033] The circuits and the transducers used to realize the price tag receivers as well as the remote updating transmitter will depend upon design choices.

### Claims

1. A system of visual communication of the price of goods on sale, comprising at least an updatable price tag placed on or about the goods, and means for manually updating the price shown, characterized in that each updatable price tag has a battery powered alphanumeric liquid crystal display, a circuitry comprising a receiver of modulated electromagnetic signals transmitted via ether, a circuit coupled to said receiver converting modulating signals of said electromagnetic signals to logic signals, a processing circuit of said logic signals generating drive signals of said liquid crystal display;

at least a battery powered supplied remote control having a keyboard for keying in updating data, a processing circuit of the signals generated by said keyboard and a transmitter of said electromagnetic signals modulated by logic signals produced by said processing circuit.

2. The system of claim 1, characterized in that said updating remote control has an alphanumeric liquid crystal display for visualizing the keyed-in data before processing and transmitting them.
3. The system according to the claim 1, in which said electromagnetic signals transmitted by said updating remote control and received by an updatable price tag are digitally modulating PWM signals.
4. The system according to an any of the preceding claims, characterized in that battery powering means of said price tags and of said remote control comprise at least a rechargeable battery and a recharging circuit directly connectable to the mains.
5. The system according to claim 1, characterized in

that said receiver of each updatable price tag and said transmitter comprise directional transducers

6. The system according to claim 1, characterized in that said electromagnetic signals are RF signals. 5

7. The system according to the claim 1, characterized in that said electromagnetic signals are IR signals.

10

15

20

25

30

35

40

45

50

55

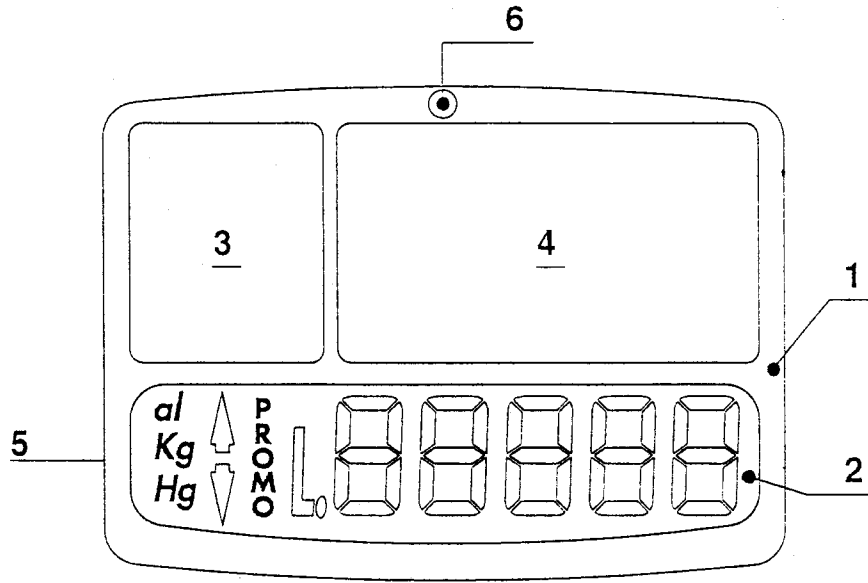

**FIG. 1**

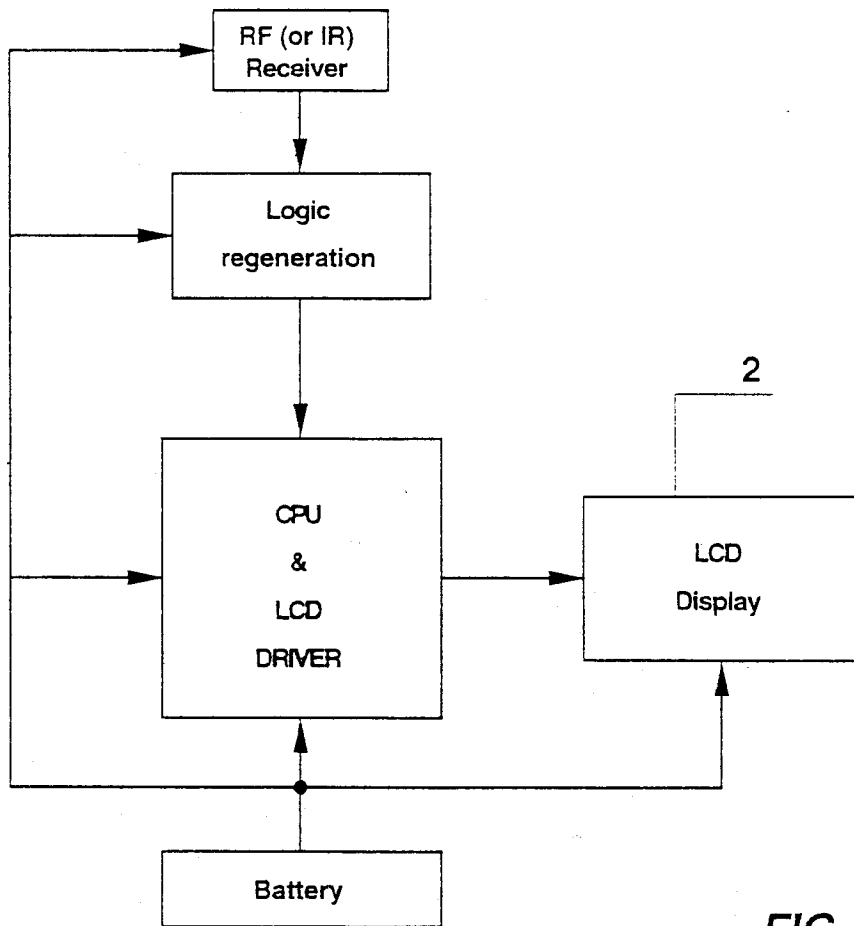

**FIG. 2**

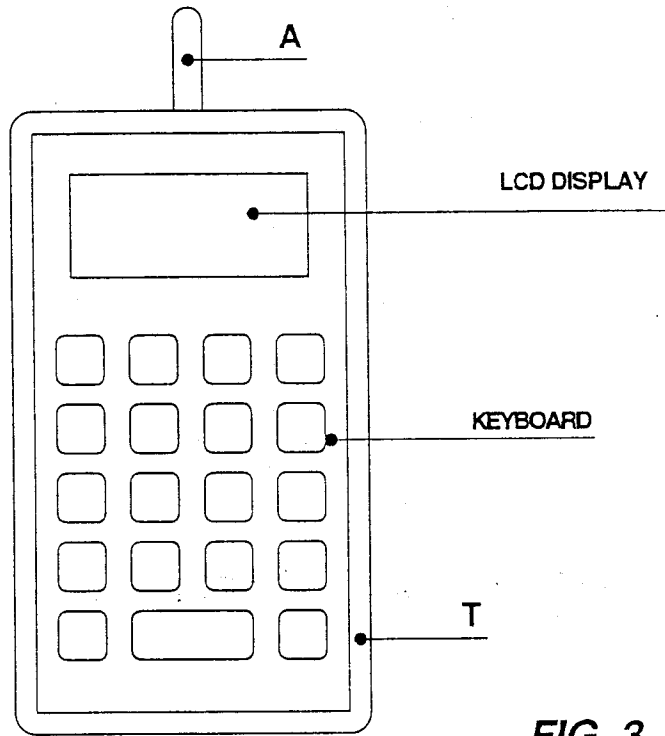

**FIG. 3**

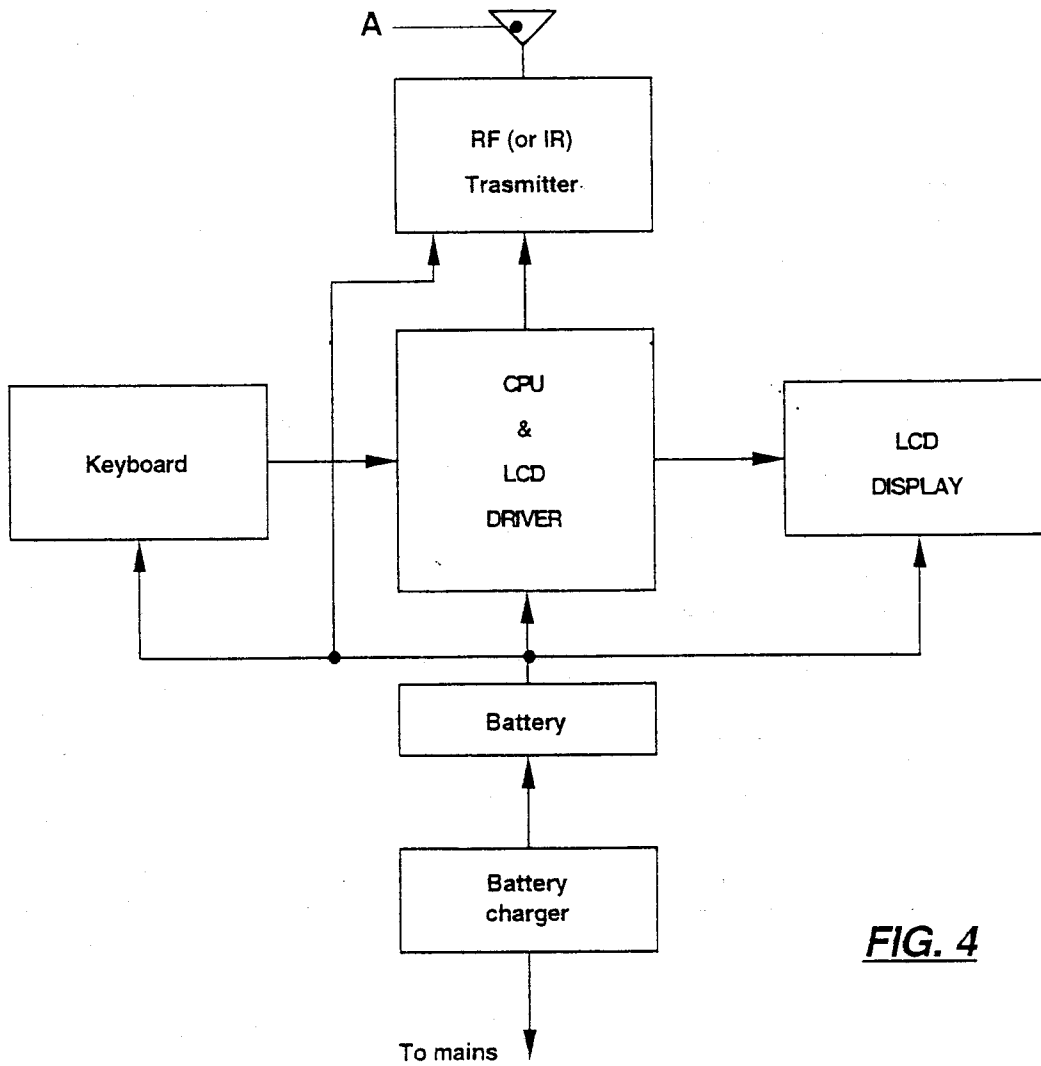

**FIG. 4**



European Patent  
Office

EUROPEAN SEARCH REPORT

Application Number  
EP 97 83 0589

DOCUMENTS CONSIDERED TO BE RELEVANT			
Category	Citation of document with indication, where appropriate, of relevant passages	Relevant to claim	CLASSIFICATION OF THE APPLICATION (Int.Cl.6)
Y	WO 97 20437 A (TAGNOLOGY) 5 June 1997 * page 7, line 18 - line 24; figure 1 * ---	1,2,4-7	G09F9/35
Y	US 5 635 915 A (T. GRAY) 3 June 1997 * abstract; figures * ---	1,2,4-7	
Y	US 4 962 466 A (M. REVESZ ET AL.) 9 October 1990 * abstract; figure 1 * ---	7	
X	EP 0 456 462 A (M. SMITH ET AL.) 13 November 1991 * column 7, line 18 - line 41; figure 6 * -----	1,2,5-7	
			TECHNICAL FIELDS SEARCHED (Int.Cl.6)
			G09F
The present search report has been drawn up for all claims			
Place of search		Date of completion of the search	Examiner
THE HAGUE		9 March 1998	Gallo, G
CATEGORY OF CITED DOCUMENTS			
X : particularly relevant if taken alone Y : particularly relevant if combined with another document of the same category A : technological background O : non-written disclosure P : intermediate document		T : theory or principle underlying the invention E : earlier patent document, but published on, or after the filing date D : document cited in the application L : document cited for other reasons ..... & : member of the same patent family, corresponding document	

EPO FORM 1503 03 82 (P04C01)

ANNEX TO THE EUROPEAN SEARCH REPORT  
ON EUROPEAN PATENT APPLICATION NO.

EP 97 83 0589

This annex lists the patent family members relating to the patent documents cited in the above-mentioned European search report. The members are as contained in the European Patent Office EDP file on  
The European Patent Office is in no way liable for these particulars which are merely given for the purpose of information.

09-03-1998

Patent document cited in search report	Publication date	Patent family member(s)	Publication date
WO 9720437 A	05-06-97	AU 1407297 A	19-06-97
US 5635915 A	03-06-97	AT 133821 T	15-02-96
		AU 645973 B	03-02-94
		AU 5528390 A	16-11-90
		WO 9013067 A	01-11-90
		CA 2051625 A	19-10-90
		DE 69025180 D	14-03-96
		DE 69025180 T	30-05-96
		EP 0469004 A	05-02-92
		ES 2085349 T	01-06-96
US 4962466 A	09-10-90	US 4888709 A	19-12-89
EP 456462 A	13-11-91	GB 2244359 A,B	27-11-91

For more details about this annex : see Official Journal of the European Patent Office. No. 12/82