

Oct. 31, 1950

D. A. BROWN ET AL

2,527,983

METHOD OF FORMING BERYLLIUM COPPER SNAP RINGS

Filed April 26, 1947

2 Sheets-Sheet 1

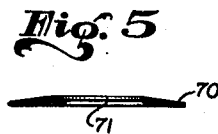
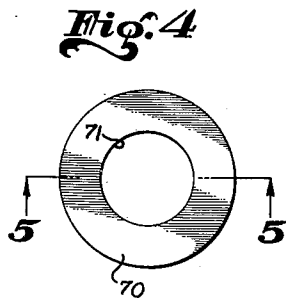
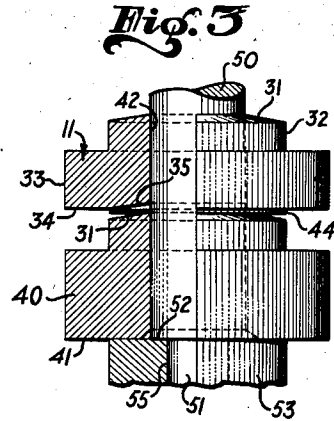
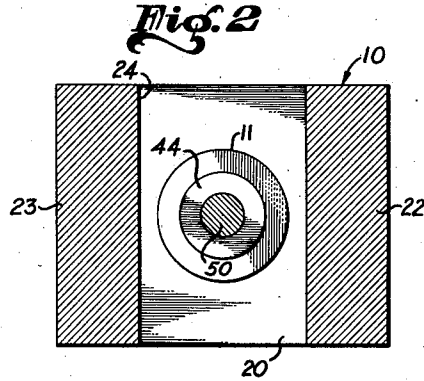
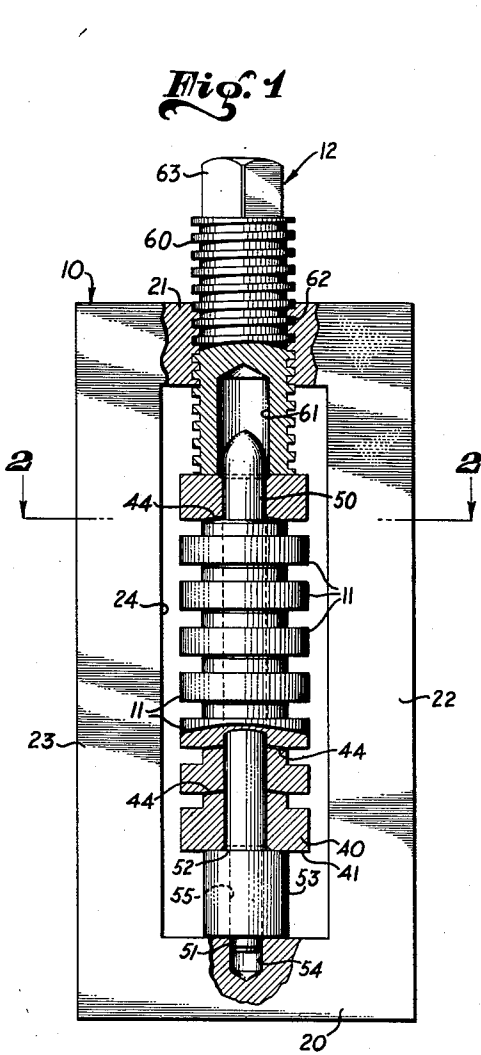

INVENTORS:
DAN A. BROWN,
THOMAS E. DOUGHERTY.
BY *Hubner, Malley
and Benker*

ATTORNEYS.

Oct. 31, 1950

D. A. BROWN ET AL

2,527,983

METHOD OF FORMING BERYLLIUM COPPER SNAP RINGS

Filed April 26, 1947

2 Sheets-Sheet 2

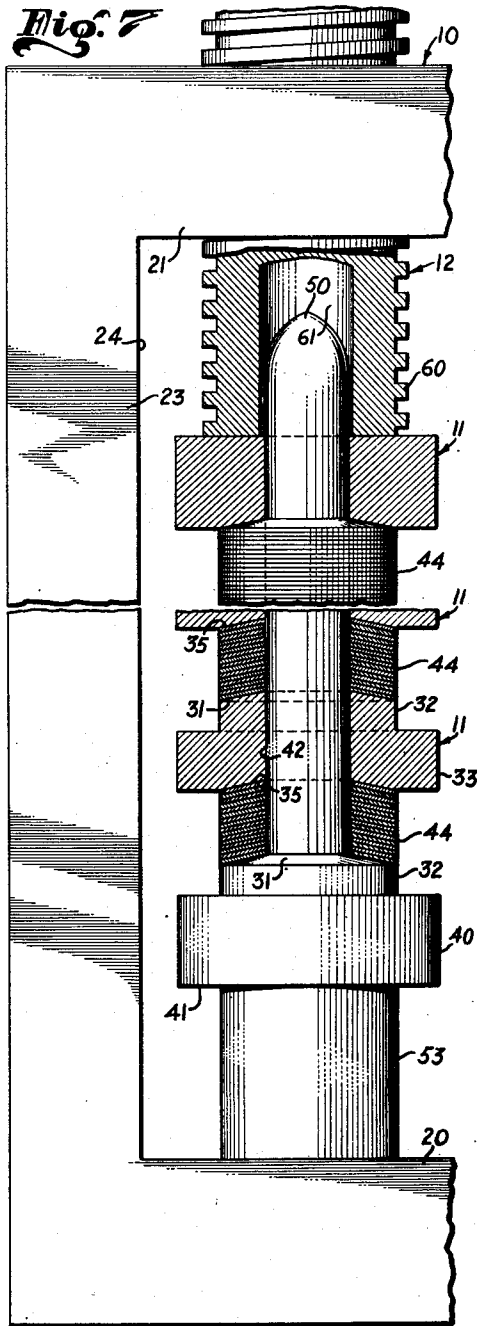
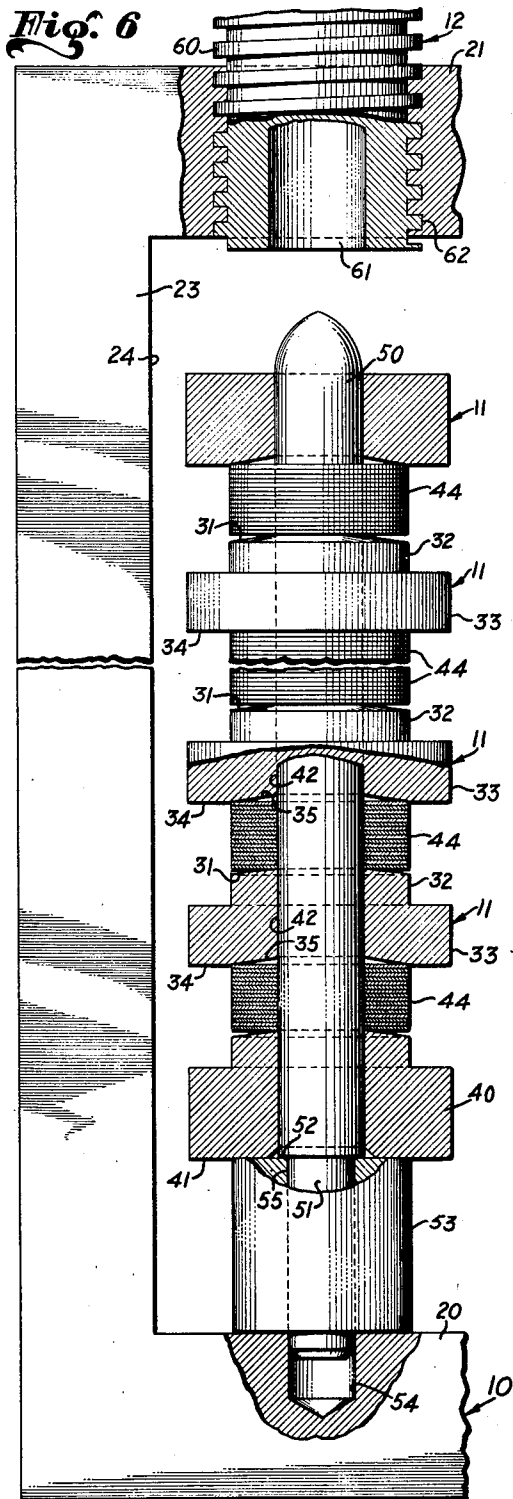

INVENTORS:
DAN A. BROWN.
THOMAS E. DOUGHERTY.
BY *Heubner, Malloy and
Becker*
ATTORNEYS.

UNITED STATES PATENT OFFICE

2,527,983

METHOD OF FORMING BERYLLIUM COPPER SNAP RINGS

Dan A. Brown and Thomas E. Dougherty, Long Beach, Calif., assignors, by mesne assignments, to Robertshaw-Fulton Controls Company, Greensburg, Pa.

Application April 26, 1947, Serial No. 744,086

2 Claims. (Cl. 148—12.7)

1

Our invention relates to a method of, and means for manufacturing sheet metal products, and is particularly adaptable and advantageous in the manufacture of beryllium copper articles requiring a high degree of accuracy, such as snap rings for thermostatic controls.

A snap ring is a disk having its center portion stretched to form a concavo-convex surface so that upon the application of forces in opposite directions at the center and the periphery thereof, the ring will snap into a reverse position.

Snap rings, as heretofore manufactured, have been made by a process of blanking and drawing usually out of stainless steel. Due to the fact that the measurements and angle of taper must be held within such close limits, it was practically always necessary to rework the stamped snap ring by hand in order to bring it within the prescribed limits of tolerance. It is clear to those skilled in the art that a snap ring formed of any spring material, such as would be necessary, must be overformed so that the natural spring back of material would result in an approximate final product. It was necessary to use large equipment, such as a 25-ton press and to continually readjust the press and test the parts to hold them within prescribed limits. One of the objects of this invention is to provide a method of, and means for manufacturing snap rings that will produce a final product having a high degree of accuracy and uniformity with comparatively little equipment and with the elimination of practically all subsequent hand adjustments.

It has been the desire of the industry for a great many years to be able to produce a snap ring of beryllium copper because of the almost infinite fatigue life of such material.

However, the heretofore known methods of production rendered it almost impossible to produce a satisfactory snap ring of beryllium copper. In attempting to draw a snap ring by the standard method, it was necessary to either draw the ring in its annealed state and then heat treat or heat treat the material and then draw the ring.

By drawing the ring in the annealed state, it was possible to obtain a fairly uniform product until heat treated. The heat treating process usually resulted in a high degree of warpage which caused substantial losses in the product. In the event that it was attempted to heat treat the material first and then draw the ring, it was necessary to overform to such an extent in order to compensate for spring back that it was practically impossible to obtain a uniform result. The difficulty arose from the fact that a press

2

needed continual adjustment, that heat treating conditions could not be held uniform, and that the thickness of stock used varied sufficiently so that the spring back of all parts was not uniform.

It is a further object of this invention to produce a snap ring of beryllium copper in such a manner that it is formed and heat treated in one operation and in such a manner that variance in the thickness of the beryllium copper stock within well-known manufacturing tolerances would not affect the final result.

Beryllium copper is an alloy of beryllium and copper which possesses good corrosion resistance, high tensile and fatigue strengths, hardness and low strain hysteresis. The most commonly used beryllium copper alloy is that known as the 2% alloy and has a composition as follows:

Be—1.90 to 2.15%
NiCoFe—0.50% maximum
Total impurities—0.50% maximum
Cu—Balance

In an alloy having less than 1.85% beryllium properties fall off rapidly. In alloys having more than 2.15% properties are not improved and difficulty is experienced in rolling and fabrication. Hard beryllium copper strips may be used in the fabrication of flat stampings but difficulty is experienced in attempting to draw $\frac{1}{2}$ or $\frac{3}{4}$ hard material because of its low ductility. However, once formed the $\frac{1}{2}$ or $\frac{3}{4}$ hard material has excellent physical properties after heat treatment.

Hardening of beryllium copper is caused by phase changes in metallurgical structure when the alloy is heated to a temperature range from 550° F. to 720° F. The best tensile properties of the dimensional control are obtained by heat treating in this temperature range for 15 to 40 minutes. However, the exact time required is difficult to ascertain because of commercially acceptable differences in the sheet stock. This difficulty, however, may be overcome by holding the temperature at approximately 600° F. for two to three hours.

Other and further objects and advantages of this invention will become apparent from the drawings and specifications relative thereto.

In the drawings:

Figure 1 is an elevational view partially in section of a fixture adapted for use in practicing our invention.

Figure 2 is a sectional view taken through line 2—2 of Figure 1.

Figure 3 is an enlarged fragmentary elevational

3

view partially in section of the fixture shown in Figure 1.

Figure 4 is a plan view of a snap ring produced by the device shown in Figure 1.

Figure 5 is a sectional view taken through line 5-5 of Figure 4.

Figure 6 is an elevational view partially in section of a modified fixture and method showing a plurality of blanks assembled in the fixture.

Figure 7 is a view similar to Figure 6 showing the assembly ready for heat treating.

Figure 1 represents by way of illustration a device adapted to practice the method claimed herein as our invention. It will readily be understood by those skilled in the art that our invention is not limited to the embodiment shown in Figure 1 and described herein, but will be applicable to a wide variety of physical embodiments adapted to produce beryllium copper parts. The device herein illustrated comprises essentially a fixture 10, a plurality of forming members 11, and a means for compressing the forming members 11, designated generally 12.

The fixture 10, as illustrated, comprises a base 20 and a head member 21 connected together by means of side members 22 and 23 forming a rectangular frame having a central opening 24. It is to be understood that the base 20, the head member 21 and the side members 22 and 23 can be formed either as an integral part, such as by milling a slot or aperture 24 in the center thereof, or can be formed of separate parts which are secured together by welding or any other suitable means. The purpose is to provide a base against which the forming members 11 can be compressed by means of the head member 21 and the compressing means 12. It is to be understood that the side members 22 and 23 are to prevent movement of the base 20 and the head member 21 with respect to each other, other than that is inherent in the elastic limits of the material, and that any structure or device adapted to prevent separation of the base 20 and head 21 should be considered an equivalent.

The forming members 11 comprise a plurality of punch and die sets, such as 30 in Figure 3. The punch and die sets in order to form the snap rings herein illustrated are circular in shape and are formed with a convex upper surface 31, the periphery of which is coextensive with the outer surface of a cylindrical portion 32, a larger cylindrical surface 33, a flat peripheral surface 34 and a concave surface 35.

It will readily be apparent that the convex surface 31 and the concave surface 35 are complementary in that their diametrical measurements and angular measurements are identical. The lowermost forming member, designated 49 in Figure 3, is formed identical with the forming member 30 with the exception that the entire lower face 41 is substantially flat. It will also be understood that the uppermost forming member 11 will be formed with a substantially flat face. Each of the forming members 11 is also formed with a centrally located axial bore 42.

In assembling the device, the forming members 11 are stacked as is shown in Figure 1 with a copper beryllium blank 44 interposed between each complementary concave and convex surface. A positioning rod 50 having a diameter equal to the bore 42 is inserted through the bore 42 to align the forming members 11. The rod 50 is formed with a reduced end portion 51 defining a shoulder 52 adapted to rest against a spacer or

4

collar 53. The base member 20 and the collar 53 are formed with bores 54 and 55 adapted to receive the reduced end portion 51. It will be apparent, of course, that the purpose of the bores 54 and 55 are to align the shaft 50.

The compressing means 12 comprises a threaded shaft 60 having a bore 61 adapted to fit over the shaft 50 and abut against the uppermost forming element 11 and is threaded into a threaded bore 62 in the head member 21. Any suitable means for tightening the compressing member, such as the square head 63, can be provided.

Figure 4 shows a typical snap ring which comprises a disk 70 having a central aperture 71. The major diameter of the disk 70 corresponds to the diameter of the convex surface 31 and the minor diameter of the disk 70 or aperture 71 corresponds to the diameter of the shaft 50.

Whereas, we have heretofore described our invention in connection with the use of a single copper beryllium blank between each of the forming members 11, it is not to be understood thereby that we intend to limit our invention to the use of a single blank between each of the successive forming members 11, but was done for purposes of simplicity. The preferred commercial embodiment is shown in Figures 6 and 7, wherein we show a method of forming copper beryllium parts and wherein we have inserted a plurality of blanks between each successive punch and die. Numerals appearing in Figures 6 and 7, which are similar to the numerals in Figures 1, 2 and 3, denote similar parts.

In Figure 6 we have illustrated the preferred commercial embodiment wherein we have disposed a plurality of blanks 44 between each of the complementary punch and die faces. We have found that satisfactory snap rings can be formed within the required tolerances by the use of as many as sixteen blanks between each of the successive forming members 11. The number of blanks which can be used successfully between each of the forming members 11 will be determined and controlled by the thickness of the material, type and degree of deformity encountered in deforming the blank to the shape of the final product, it being clear, of course, that in cases where material is thicker or deformation more severe, fewer blanks can be inserted between each of the forming members.

Figure 7 is a view similar to Figure 6 and shows an assembled fixture ready for heat treating, and having a plurality of blanks 44 between each of the forming members 11, and in which a compression member 12 has been screwed down against the top of the assembly and is exerting sufficient pressure on the top of the forming members 11 to temporarily deform the blanks 44 to the shape of the final product. The blanks 44, when heat treated and subjected to severe pressures generated due to the difference in thermal expansion between the copper beryllium and the frame 10, will retain the shape shown in Figure 6 or in which they were heat treated.

After assembling the forming members 11 in position with the snap ring blank 44 in place, the compressing means is tightened by means of a wrench or other suitable device so that the snap ring blank 44 assumes the angular shape corresponding to the surfaces 31 and 35. The entire assembly is then placed in a suitable furnace and heated to approximately 600° F. for approximately 3 to 4 hours. The reason the assembly is left in the furnace for this period of time is to

5

make sure that the entire assembly has reached a uniform temperature.

In the event that it is desired to speed up the process, the assembly can be placed in a furnace at approximately 700° F. for approximately 15 minutes. The danger, however, of such a procedure lies in the fact that the die or forming jig may not be uniformly heated and that if the parts are left at that temperature too long, the beryllium copper tends to soften.

It will readily be understood by those skilled in the art that the above-described process results in the application of the substantially large force on the beryllium copper parts at a temperature which hardens the parts while being formed. The reason for the application of such large forces to the copper beryllium parts while they are being formed lies in the difference in coefficient of thermal expansion between beryllium copper and the material from which the frame is formed. The beryllium copper has a substantially larger coefficient of expansion than, for example, a steel frame.

It is apparent that the amount of the force applied to beryllium copper in the forming operation will be confined within the elastic limits of the frame 10.

Thus, it will be seen that we have provided a method of forming copper beryllium parts and of applying substantially large pressures to the formation of the copper beryllium parts while simultaneously hardening the material.

By forming copper beryllium snap rings by means of the above-disclosed method a surprisingly uniform and accurate product can be obtained.

We have found by practising our invention that copper beryllium snap rings requiring an angular concavity of 6° plus or minus 15 minutes can be produced with practically no rejects or loss. When it is realized that the snap ring will not function properly if it is formed with more than 1° variation from 6°, and when it is realized that in order to draw the heat treated blank to a 6° angle, the punch and die must be ground to approximately 12°, the advantages to be derived from such a method as disclosed herein becomes apparent.

It is well known to those skilled in the art that in drawing the copper beryllium part the final product will be affected by thickness of the stock, the method and degree of heat treating, the direction of grain, and the pressure of the forming press, and that none of the above elements can with absolute accuracy be held uniform; that, therefore, it has heretofore been for practical purposes impossible to form copper beryllium snap rings.

Whereas, we have described our invention in connection with the manufacture of copper beryllium snap rings, it is apparent that the true import of the invention lies in the broader aspect of using the process in connection with forming sheet material parts of any springy and/or heat treatable metallic material where a high degree of accuracy is necessary.

It is further to be understood that we do not wish our invention to be limited to the formation of copper beryllium snap rings, but deemed to be in a much broader application and that any

6

process which includes the steps of forming sheet metal parts whereby the part is formed and heat treated simultaneously between complementary punches and dies and whereby a substantially large force is applied to the forming operation by reason of a differential in thermal expansion between the part to be formed and the complementary punches and dies, will come within the scope of our invention.

Having described our invention, what we claim as new and desire to secure by Letters Patent is:

1. A method of forming annular symmetrical substantially concavo-convex beryllium copper snap rings comprising the steps of placing a plane flat ring of copper beryllium in an annealed state between each of a plurality of forming blocks having fully complementary faces conforming to the exact configuration of the opposite surfaces respectively of the snap ring in final form assembled in a frame having a lower coefficient of thermal expansion than the combined copper beryllium rings and the forming blocks, exerting an axial compression on said forming blocks to shape said rings to their final configuration, heating the rings and blocks at such temperatures and for such time as to harden the rings, and throughout the heating period maintaining said axial compression exerted in the shaping step thereby providing a greatly increased effective axial compression of the blocks on the rings due to the difference in the thermal expansion of the rings and blocks and the frame whereby variation in the rings is minimized.

2. A method of forming annular symmetrical substantially concavo-convex beryllium copper snap rings comprising the steps of placing a plurality of plane flat rings of copper beryllium in an annealed state between each of a plurality of forming blocks having fully complementary faces conforming to the exact configuration of the opposite surfaces respectively of the snap rings in final form assembled in a frame having a lower coefficient of thermal expansion than the combined copper beryllium and the forming blocks, exerting an axial compression on said forming blocks to shape said rings to their final configuration, heating the rings and blocks at such temperatures and for such time as to harden the rings, and throughout the heating period maintaining said axial compression exerted in the shaping step thereby providing a greatly increased effective axial compression of the blocks on the rings due to the difference in the thermal expansion of the rings and blocks and the frame whereby variation in the rings is minimized.

DAN A. BROWN.

THOMAS E. DOUGHERTY.

REFERENCES CITED

The following references are of record in the file of this patent:

UNITED STATES PATENTS

Number	Name	Date
1,346,946	Fay	July 20, 1920
1,668,297	Wuerfel	May 1, 1928
2,309,518	Luers	Jan. 26, 1943
2,326,022	Everett	Aug. 3, 1943
2,332,826	Fryer et al.	Oct. 26, 1943

70