

May 22, 1962

W. F. HELLMAN

3,035,564

DART GUN TOY

Filed May 1, 1959

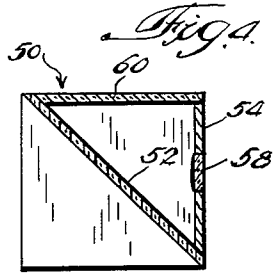
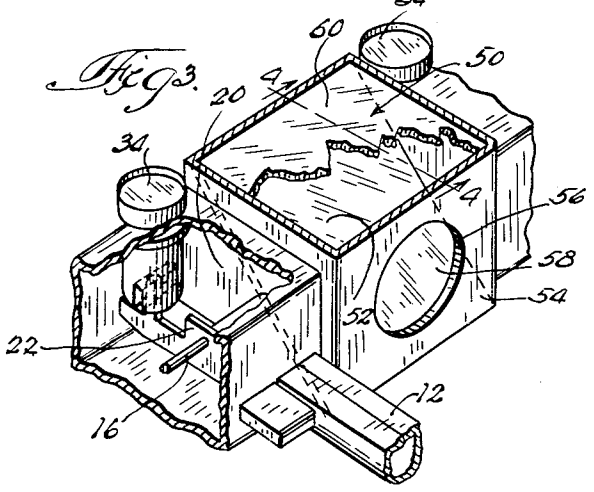
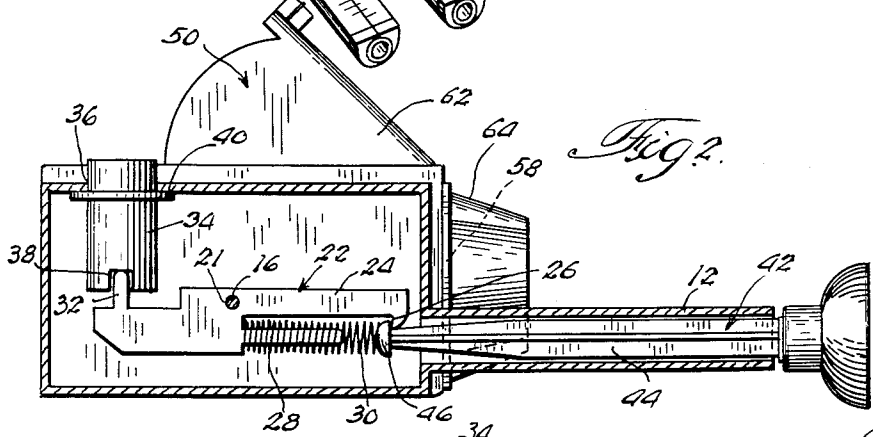
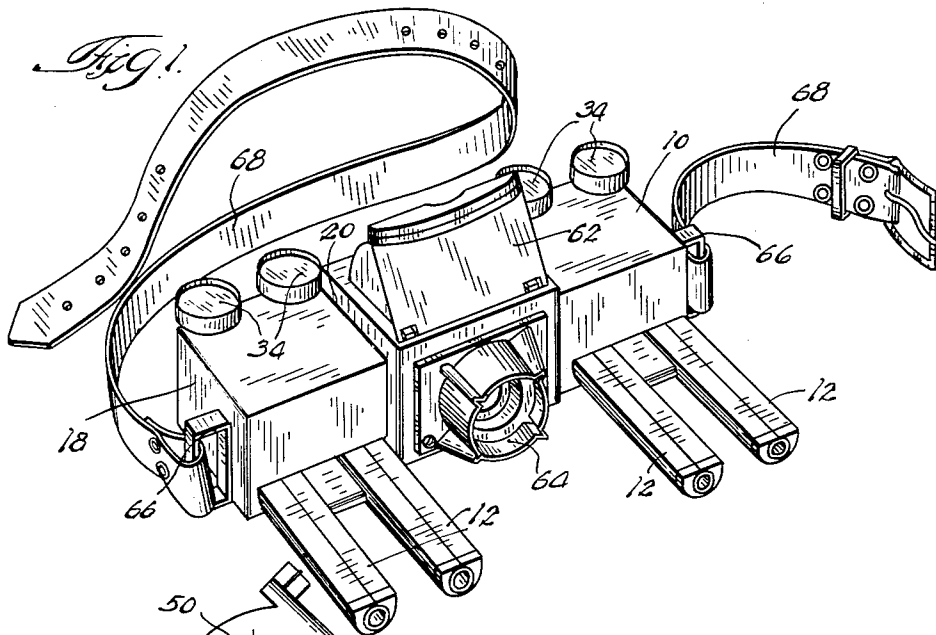

INVENTOR.
Werner F. Hellman
BY. Max R. Kraus
[Signature]

1

3,035,564

DART GUN TOY

Werner F. Hellman, 8838A Robin Drive, Chicago, Ill.

Filed May 1, 1959, Ser. No. 810,445

3 Claims. (Cl. 124-26)

This invention relates to a dart gun toy.

One of the objects of this invention is to provide a toy having a plurality of dart guns and sighting means incorporated therewith.

Another object of this invention is to provide a toy having a plurality of dart guns which may be worn around the waist of the child.

Another object of this invention is to provide a toy of the foregoing character which is comparatively inexpensive to manufacture and which provides great play value.

Other objects will become apparent as this description progresses.

In the drawings:

FIGURE 1 is a perspective view of the toy.

FIGURE 2 is an enlarged view partly in cross-section taken on lines 2-2 of FIGURE 1.

FIGURE 3 is a perspective view with parts in section showing the sighting position and the means for actuating the dart, and

FIGURE 4 is a cross-sectional view taken on lines 4-4 of FIGURE 3.

The structure shown in the drawings consists of a generally rectangular shaped housing indicated by the numeral 10 which has four barrels or sleeves generally indicated at 12 extending forwardly thereof and communicating with the interior of the housing. The barrels 12 are arranged in pairs on the opposite sides, as shown in FIGURE 1. Each of the barrels 12 forms the barrel of a dart gun for shooting a dart. The trigger mechanisms of all of the dart guns are identically constructed, hence only one will be described in detail and same is best shown in FIGURE 2. It is understood that all of the guns are operated in precisely the same manner, each dart gun being individually operated.

Fixedly supported within the housing at each of the opposite ends is a pin 16, one end of said pin being supported in the end wall 18 of the housing 10 and the opposite end being supported in an intermediate wall 20. The two spaced intermediate walls 20 form the side walls of the sighting unit to be subsequently described. Pivotaly supported as at 21 on pin 16 is a lever generally indicated at 22, each lever being positioned in alinement with its respective barrel 12. The lever 22, best shown in side elevation in FIGURE 2 has a stem portion 24 which terminates in a hooked end 26 at the forward end thereof and has a finger portion 28 projecting forwardly of the pivot point 21 and below the stem 24 to support a coil spring 30. When the coil spring 30 is not compressed it will extend into the barrel 12. The lever 22 extends rearwardly of the pivot point 21 and is provided with an upwardly extending portion 32 adjacent the rear end thereof which is adapted to engage a button member generally indicated at 34.

The button member 34 which comprises a generally circular body is loosely received within an opening 36 in the top wall of the housing 10 and the bottom of said button member has a recess 38 which fits on said upwardly projecting finger 32. The button member has an annular shoulder 40 which limits the upward movement of same, thereby limiting the pivoting movement of the lever 22.

The dart member generally indicated at 42 includes a stem 44 having a shoulder 46 at the rear end thereof. The forward end of the dart is provided with a conventional suction cup 48 as is well understood. The dart

2

is inserted into the barrel 12 of the toy and is pushed rearwardly, compressing the spring 30. The dart 42 is pushed rearwardly so that the shoulder 46 of the dart engages the curved front end of the hook 26 and pivots the lever 22 to permit the shoulder 46 to pass rearwardly of the hook 26. As the spring 30 is compressed against the lower side of the lever 22 the lever will be pivoted to that the hooked end 26 of the lever moves downwardly to engage the shoulder 46 of the dart, as shown in FIGURE 2. The button 34 will thus be elevated until the annular shoulder 40 engages the underside of the top of the housing to limit its upward movement. The gun is then in a cocked position and is ready to be actuated. By depressing the button 34 the lever 22 is pivoted so that the forward end of said lever moves upwardly thereby releasing the hooked end 26 from engagement with the shoulder 46 of the dart 42, and due to the spring 30 the dart will be projected forwardly out of the barrel 12 to the target.

As best shown in FIGURE 1, the toy gun is here provided with four separate gun mechanisms and with four separate buttons 34, each button 34 operating its respective gun mechanism. Any greater or lesser number of such gun mechanisms may be provided.

Centrally of the housing 10 there is provided the sighting unit generally indicated at 50, which will now be described. Between the opposite intermediate walls 20 there is provided an inclined mirror 52 which serves as a reflecting surface. In the front wall 54 of the housing of said intermediate portion is an opening 56 which receives a lens 58. Extending across the top of the sighting unit 50 is a horizontally positioned frosted glass 60 which is provided with suitable lines and circles to aid in sighting. A light shield generally indicated at 62 is secured to the top of the housing over the glass plate 60. A hood 64 is secured to the front of the housing forwardly of the lens 58.

The target area may be properly sighted through the sighting unit 50 which is centrally located and each of the dart guns may be operated simply by pressing each of the buttons 34 to release its respective dart, all as previously described. The darts may be released in successive order or may be released simultaneously as desired.

Secured to each of the opposite sides 18 of the housing 10 is a bracket member 66 which may serve as a handle if the toy is held in the hand, or said brackets may have secured thereto the opposite ends of a belt member generally indicated by the numeral 68 for the purpose of strapping the toy around the waistline of a child. By thus strapping the toy to the child, the child may play without being hindered by the toy and the toy may be used by the child when desired.

The toy provides a great deal of amusement for the child. It gives the child the practice of sighting an object, which may be done by looking down at the centrally positioned sighting means 50. By viewing the frosted glass surface 60 and aligning the lens 58 of the sighting device in line with the target area, a proper sighting may be effected. The toy darts 42 may be released individually or successively or simultaneously simply by pressing on the buttons 34, as previously described.

It will be understood that various changes and modifications may be made from the foregoing without departing from the spirit and scope of the appended claims.

I claim:

1. In a toy of the character described, a housing, a plurality of barrels extending forwardly of said housing, a trigger mechanism for each said barrel supported within said housing and in alinement with each said barrel, a dart insertable in each said barrel and adapted to be releasably secured therein, means for operating each trig-

3

ger mechanism separately to release each said dart, said means having a member extending upwardly of the top of the housing to be manually depressed for releasing the dart, and a sighting device secured in said housing for alining said toy with the target object, said sighting device including an inclined reflecting surface inside said housing, a sighting glass in the top of the housing forwardly of the dart releasing members, a lens secured forwardly of said reflecting surface and rearwardly of the fronts of said barrels to permit sighting forwardly and in the forward direction of flight of said darts, and a light shield extending upwardly of said housing in alinement with said reflecting surface.

2. The toy defined in claim 1 having a belt for securing said toy about the waist of a child.

3. In a toy of the character described, a housing, a plurality of barrels extending forwardly of said housing, a trigger mechanism for each said barrel supported within said housing and in alinement with each said barrel, a dart insertable in each said barrel and adapted to be releasably secured therein, means for operating each trigger mechanism separately to release each said dart, said

4

means extending upwardly to the top of said housing to be manually depressed for releasing the dart, a sighting device secured in said housing for alining said toy with the target object, said sighting device including a reflecting surface inside said housing and a lens positioned forwardly of said reflecting surface and rearwardly of the fronts of said barrels to permit sighting forwardly of said barrels and in the forward direction of flight of said darts, said sighting device including a sighting glass in the top of the housing forwardly of the dart releasing means, and means for securing said toy to a child so that the child's hands are free to operate the trigger mechanism.

References Cited in the file of this patent

UNITED STATES PATENTS

1,988,191	Donato	Jan. 15, 1935
2,483,164	Wheeler	Sept. 27, 1949
2,663,969	Kellogg	Dec. 29, 1953
2,888,004	Steiner	May 26, 1959

FOREIGN PATENTS

914,654	France	June 24, 1946
---------	--------	---------------