

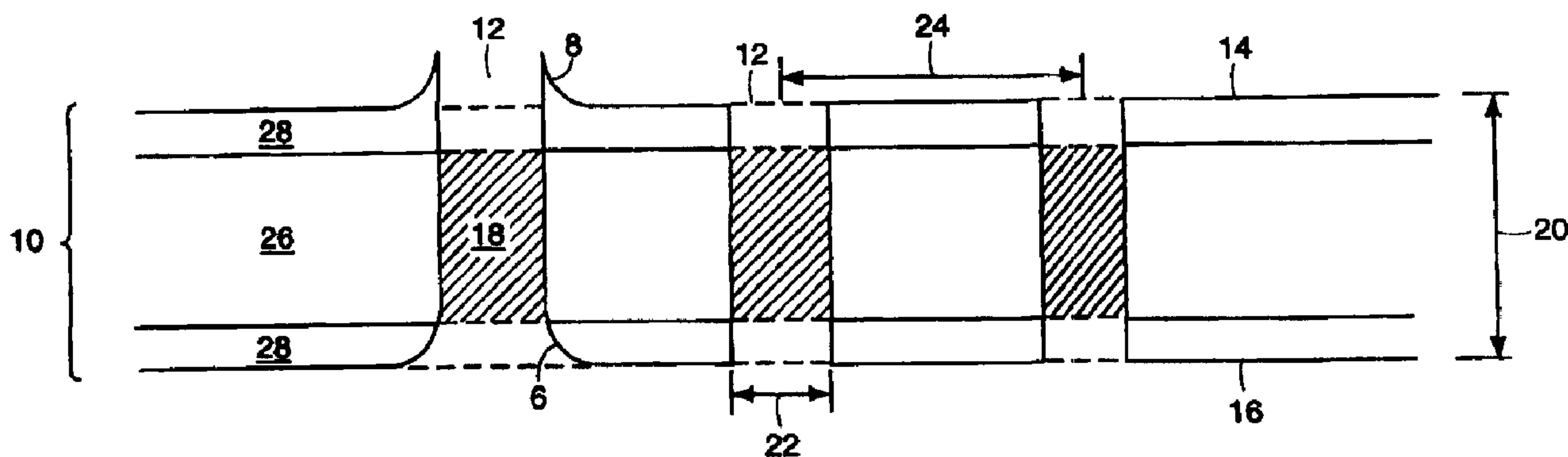

(86) Date de dépôt PCT/PCT Filing Date: 1999/01/05
 (87) Date publication PCT/PCT Publication Date: 1999/07/15
 (45) Date de délivrance/Issue Date: 2009/09/15
 (85) Entrée phase nationale/National Entry: 2000/06/29
 (86) N° demande PCT/PCT Application No.: US 1999/000088
 (87) N° publication PCT/PCT Publication No.: 1999/034920
 (30) Priorité/Priority: 1998/01/12 (US60/071,179)

(51) Cl.Int./Int.Cl. *B01L 3/00* (2006.01),
G01N 35/00 (2006.01)
 (72) Inventeur/Inventor:
HUNTER, IAN W., US
 (73) Propriétaire/Owner:
MASSACHUSETTS INSTITUTE OF TECHNOLOGY, US
 (74) Agent: GOWLING LAFLEUR HENDERSON LLP

(54) Titre : PROCÉDE POUR EFFECTUER DES DOSAGES MICROSCOPIQUES
 (54) Title: METHOD AND APPARATUS FOR PERFORMING MICROASSAYS



(57) Abrégé/Abstract:

A system and method for analyzing a plurality of liquid samples. The system has a platen having two substantially parallel planar surfaces and a plurality of through-holes dimensioned so as to maintain a liquid sample in each through-hole by means of surface tension. A source of optical radiation illuminates the through-holes, and an optical arrangement analyzes the light emanating from the through-holes. The through-holes may be individually addressable, and may have volumes less than 100 nanoliters. Samples may be drawn from a planar surface by capillary action and may be accurately dispensed, diluted and mixed in accordance with embodiments of the invention.



PCT

WORLD INTELLECTUAL PROPERTY ORGANIZATION
International Bureau

INTERNATIONAL APPLICATION PUBLISHED UNDER THE PATENT COOPERATION TREATY (PCT)

| | | |
|---|---|---|
| (51) International Patent Classification ⁶ : B01L 3/00 | A1 | (11) International Publication Number: WO 99/34920 (43) International Publication Date: 15 July 1999 (15.07.99) |
| <p>(21) International Application Number: PCT/US99/00088</p> <p>(22) International Filing Date: 5 January 1999 (05.01.99)</p> <p>(30) Priority Data: 60/071,179 12 January 1998 (12.01.98) US</p> <p>(71) Applicant: MASSACHUSETTS INSTITUTE OF TECHNOLOGY [US/US]; 77 Massachusetts Avenue, Cambridge, MA 02139 (US).</p> <p>(72) Inventor: HUNTER, Ian, W.; 6 Oakdale Lane, Lincoln, MA 01773 (US).</p> <p>(74) Agents: SUNSTEIN, Bruce, D. et al.; Bromberg & Sunstein LLP, 125 Summer Street, Boston, MA 02110-1618 (US).</p> | <p>(81) Designated States: AL, AM, AT, AU, AZ, BA, BB, BG, BR, BY, CA, CH, CN, CU, CZ, DE, DK, EE, ES, FI, GB, GD, GE, GH, GM, HR, HU, ID, IL, IN, IS, JP, KE, KG, KP, KR, KZ, LC, LK, LR, LS, LT, LU, LV, MD, MG, MK, MN, MW, MX, NO, NZ, PL, PT, RO, RU, SD, SE, SG, SI, SK, SL, TJ, TM, TR, TT, UA, UG, UZ, VN, YU, ZW, ARIPO patent (GH, GM, KE, LS, MW, SD, SZ, UG, ZW), Eurasian patent (AM, AZ, BY, KG, KZ, MD, RU, TJ, TM), European patent (AT, BE, CH, CY, DE, DK, ES, FI, FR, GB, GR, IE, IT, LU, MC, NL, PT, SE), OAPI patent (BF, BJ, CF, CG, CI, CM, GA, GN, GW, ML, MR, NE, SN, TD, TG).</p> <p>Published <i>With international search report. Before the expiration of the time limit for amending the claims and to be republished in the event of the receipt of amendments.</i></p> | |

(54) Title: METHOD AND APPARATUS FOR PERFORMING MICROASSAYS

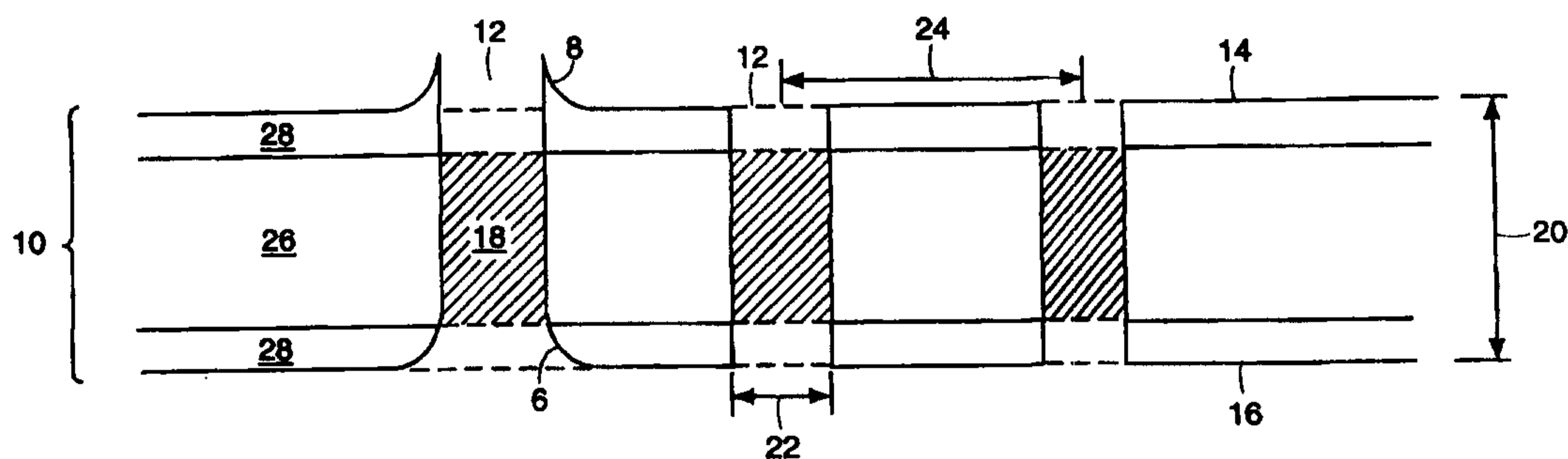

(57) Abstract

A system and method for analyzing a plurality of liquid samples. The system has a platen having two substantially parallel planar surfaces and a plurality of through-holes dimensioned so as to maintain a liquid sample in each through-hole by means of surface tension. A source of optical radiation illuminates the through-holes, and an optical arrangement analyzes the light emanating from the through-holes. The through-holes may be individually addressable, and may have volumes less than 100 nanoliters. Samples may be drawn from a planar surface by capillary action and may be accurately dispensed, diluted and mixed in accordance with embodiments of the invention.

Method and Apparatus for Performing Microassays

5

Technical Field

The present invention pertains to an apparatus and method for manipulating, transporting, and analyzing a large number of microscopic samples of a liquid or of materials including cells currently or formerly in liquid suspension.

10

Background of the Invention

Chemistry on the micro-scale, involving the reaction and subsequent analysis of quantities of reagents or analytes of order microliters or smaller, is an increasingly important aspect of the development of new substances in the pharmaceutical and other industries. Such reaction and analysis may accommodate vast libraries containing as many as a million compounds to be reacted and analyzed under various conditions. Significant problems associated with current technologies as applied to chemical analysis of vast numbers (potentially on the order of hundreds of thousands or millions per day) of compounds include the problem of handling vast numbers of compounds and reactions in parallel.

20

Existing technology relies on 96-, 384-, or 1536-well plates containing quantities between approximately 1 microliter and 1 milliliter of liquid compound per well, and, generally, involves chemical reactions and analysis in wells disposed with single openings on flat, two-dimensional surfaces such as silicon chips. It is not practical to apply existing technology in the art to form million-well disks. There is a need, therefore, for new approaches that permit the analysis of a million samples in a laboratory format.

25

Summary of the Invention

30

In accordance with one aspect of the invention, in one of its embodiments, there is provided a method for selecting samples having specified properties from a library of samples. The method has the steps of:

- 5 a. providing a platen having two substantially parallel planar surfaces and a plurality of addressable through-holes disposed substantially perpendicularly to the planar surfaces;
- b. loading a first sample in liquid form into at least one of the through-holes;
- c. adding a second sample into the at least one of the through-holes for
- 10 permitting a reaction between the first sample and the second sample; and
- d. characterizing the reaction in the through-hole in terms of the specified properties.

In accordance with alternate embodiments of the invention, each through-hole may be dimensioned so as to maintain a liquid sample therein by means of surface

15 tension, and may have a volume less than 100 nanoliters. The plurality of addressable through-holes may have a density in excess of 10^8 per square meter.

In accordance with further alternate embodiments of the invention, the step of loading a first sample may include drawing the sample from a planar surface by capillary action. The platen may be brought into contact with a reservoir of liquid and rotated

20 about an axis perpendicular to the surface of the reservoir or about at least one of an axis perpendicular to the surface of the reservoir and an axis parallel to the surface of the reservoir. The method may include the further step of maintaining a humid atmosphere for preventing evaporation of the first sample or coating the liquid sample with a monolayer for preventing evaporation of the first sample.

- 25 In accordance with a further aspect of the present invention, a method is provided for preparing a plurality of combinations of members of a first set of samples in liquid form with members of a second set of samples in liquid form, the method comprising:
- a. providing a first perforated platen having through-holes and a second perforated platen having through-holes;
- 30 b. loading a first set of samples in liquid form into the through-holes of the first perforated platen;
- c. loading a second set of samples in liquid form into the through-holes of the second perforated platen;
- d. registering the through-holes of the first perforated platen with the through-
- 35 holes of the second perforated platen; and
- e. combining the first set of samples with the second set of samples.

5 In accordance with yet further aspects of the present invention, there are provided methods for mixing and diluting liquid samples. The methods have steps of loading one set of liquid samples into through-holes of a first platen and loading another set of liquid samples into through-holes of a second platen, and then disposing a surface of the first platen in contact with a surface of the second platen in such a way as to register at least one through-hole of the first platen with at least one of through-hole of the second platen for permitting mixing of the liquid samples of the respective sets.

10 In accordance with another aspect of the present invention, there is provided a system for analyzing a plurality of liquid samples. The system has a platen having two substantially parallel planar surfaces and a plurality of through-holes having apertures and walls, a source of optical radiation for illuminating at least one through-hole along an optical axis, and an optical arrangement for analyzing light emanating from the at least one through-hole.

Brief Description of the Drawings

20 The foregoing features of the invention will be more readily understood by reference to the following detailed description taken with the accompanying drawings in which:

FIG. 1 is a side view in cross-section of a portion of a laminated platen containing multiple through-holes for analysis of liquid samples in accordance with a preferred embodiment of the present invention;

FIG. 2A is top view of a portion of the platen of FIG. 1 in which the through-holes are configured on rectangular centers;

FIG. 2B is top view of a portion of the platen of FIG. 1 in which the through-holes are configured in a hexagonal close-packed array;

30 FIG. 3 is a top view of round sample wafer populated with through-holes in accordance with an embodiment of the present invention;

FIG. 4 is a side perspective view of an arrangement for loading a liquid sample into the platen of FIG. 1 by employing capillary and inertial insertion forces;

35 FIG. 5 is a cut-away view of a single through-hole in the platen of FIG. 1, showing the use of hydrophobic and hydrophilic layers for containment of an aqueous sample;

5 FIG. 6 is schematic diagram of a confocal optical arrangement for interrogation of a liquid sample in a through-hole in accordance with an embodiment of the present invention;

10 FIG. 7 is perspective view of a scanning arrangement for serially interrogating liquid samples retained in through-holes of a disk-type platen in accordance with an embodiment of the present invention;

 FIG. 8 is schematic representation of a scanning arrangement for serially interrogating liquid samples retained in a continuous-process film-type platen, in accordance with an alternate embodiment of the present invention;

15 FIG. 9 is a cross-sectional view of portions of two platens brought into proximity with through-hole registration in anticipation of mixing or dilution in accordance with embodiments of the present invention; and

 FIG. 10 is a cross-sectional view of the portions of two platens of FIG. 9 after the two platens have been brought into contact to facilitate mixing or dilution.

20 Detailed Description of Preferred Embodiments

Through-hole wells

 In accordance with a preferred embodiment of the invention, the volume of each well employed for the assay of a chemical or biochemical reaction is reduced typically to less than 100 nanoliters (10^{-10} m^3). The packing density of wells may thereby be
25 increased by several orders of magnitude over prior art technology. Referring to FIG. 1, a side view is shown in cross section of a platen **10**, otherwise referred to herein as a "substrate" or "sample wafer." Platen **10** is the carrier of a large number of through-holes **12** which traverse platen **10** from one surface **14** to an opposing surface **16** of the platen and constitute assay wells (or "microwells") in accordance with an embodiment of
30 the invention. Through-holes **12** may be shaped as circular right cylinders, or, alternatively, may have rectangular cross-sections, however otherwise shaped through-holes are within the scope of the present invention. As used in the present description and in the appended claims, the term "platen" refers to a structure having substantially parallel plane surfaces and transverse dimensions substantially exceeding the thickness
35 of the structure between the substantially parallel plane surfaces.

5 The apertures of through-holes **12** need not be square, and, in accordance with an alternate embodiment of the present invention, flanges **8** may extend above planar surface **14** surrounding some or all of through-holes **12** while indentations **6** may be fabricated rounding the edges of through-holes **12** at opposing surface **16**. Flanges **8** and indentations **6** may advantageously provide for registration of successive platens **10**, in the case where platens are stacked, and in processes of mixing or dilution, as discussed in detail below in reference to Figs. 9-10.

10 In accordance with an embodiment of the invention, through-holes **12** are loaded with a first sample **18** in liquid form. Sample **18** is allowed to react with a second sample where the second sample may include a variety of test samples and by subsequent or concurrent analysis of the reaction products, using, for example, optical markers, a large number of reactions may be processed and analyzed in parallel.

15 As applied to biological assays, by way of example, first sample **18** may be a reagent, including, for example, cells in aqueous suspension, eukaryotic (animal, yeast) or prokaryotic (bacteria) cells, hybrid cells, and biological molecules including, for example, antibodies and enzymes, although application to other biological or non-biological assays is within the scope of the invention as claimed herein. All such reagents may also be referred to herein and in the appended claims as "targets." Typical yeast cell concentrations of 10^7 cells per milliliter of solution yield on the order of 1000 cells per 100 nanoliter well. Typically, an entire chip or the subset of through-hole wells constituting a contiguous region of platen **10** may be populated with a single strain of cells.

20 A typical procedure assay procedure, such as may be employed in pharmaceutical research, entails the subsequent addressed introduction of a test sample including one or more analytes into the through-hole wells, with selected materials introduced into subsets of through-holes that may include one or more through-holes. The test sample addressably introduced into the subsets of through-holes may contain drug candidates or known drugs. The test sample may be comprised of multiple components, introduced at the same time or sequentially. Components of the test sample may include analytes, antagonists, reagents, solvents, or any other materials and may be introduced in liquid form or otherwise. In accordance with a preferred embodiment of the invention, test

25

30

35

5 samples are introduced into the through-hole wells in liquid form in order to facilitate rapid reaction via diffusion with first sample 18 already resident in liquid form in the through-holes.

10 The set of substances from which the second sample addressed to a particular through-hole site is drawn is referred to in this description and in the appended claims as a "library" of substances. In typical applications, the library is of a substantial size and thus advantageously utilizes the capability of the present invention to facilitate parallel reaction and analysis of large numbers of substances. In pharmaceutical applications in particular, libraries may be composed of between 10^3 and 10^9 substances and combinations of substances.

15 A typical thickness 20 of platen 10 is on the order of 1-2 mm, while through-holes 12 have typical characteristic dimensions (such as diameters) 22 of on the order of 100-400 μm . Thus the volume of each through-hole 12 between surface 14 and surface 16 is on the order of $\sim 10^{-7}$ cm^3 or greater. Through-holes 12 are spaced on centers typically on the order of twice the diameter of the holes, although all spacing configurations are within the scope of the invention and of the appended claims. In particular, through-holes 12 may be centered on a rectangular grid, as shown in FIG. 2A, or in a close-packed hexagonal lattice, as shown in FIG. 2B.

20 In accordance with an alternate embodiment of the present invention described with reference to FIG. 3, through-holes 12 may be disposed in an array within a circular sample wafer 300 having a central hole 302 for purposes of centering with respect to handling equipment.

25 Referring again to FIG. 1, platen 10 may be any solid or quasi-solid material into which through-holes 12 may be formed. In particular, in accordance with various embodiments of the invention, platen 10 may be formed from metal, semiconductor, glass, quartz, ceramic or polymer materials, all given without limitation by way of example. In accordance with a preferred embodiment of the invention, platen 10 is formed in a format associated with a compact disk read-only-memory (CD-ROM) - namely that of a polymer disk, approximately 1.2 mm in thickness, and approximately 100 mm in diameter.

5 Platen **10** may also advantageously be formed of a laminate of materials, with a central layer **26** and outer "sandwiching" layers **28**. Advantages of this construction for containment of sample **18** will be discussed further below.

10 Through-holes **12** may be formed in platen **10** by means appropriate to the material of platen **10**. Through-hole forming methods include, by way of example, laser ablation by means of an ultraviolet (UV) excimer laser which may form 100 μm through-holes in glasses and polymers. Additional through-hole forming techniques include mechanical drilling, electrochemical methods, or selective chemical or charged-particle etching techniques. Additionally, microcapillary bundles of glass fibers of varying compositions may be drawn from preform and sliced to form platens, and then
15 selectively etched to form through-holes.

Loading the through-hole microwells

 On the size scale employed in accordance with embodiments of the invention, where through-holes **12** have aspect ratios of axial length to diameter greater than unity, viscous forces may dominate inertial forces in governing the fluid kinetics of material in the through-hole wells. Consequently, capillary action may be employed to populate through-holes **12** with sample fluid **18**. Referring to FIG. 4, two aspects of loading the through-hole wells are described with reference to a sample insertion apparatus **30**. Since through-hole microwells **12** are open at both sides, insertion of liquid into the wells does not require that the air displaced by the liquid on insertion flow through the entering fluid, as occurs in the prior art well structure having only a single aperture for influx of liquid and efflux of displaced air. Liquid **32**, loaded into reservoir **34** via port **33**, may, as discussed above, contain cells or other particles in suspension. Liquid **32** may be forced into through-hole microwells **12** (shown in FIG. 1) by in-line impulsion as by driving
20 platen **10** into liquid **32** by force applied along direction **36** transverse to the plane of platen **10**. The transverse piston force may be applied via shaft **38** or in any other manner known in the mechanical arts.
25

 In accordance with another embodiment of the invention, liquid may also be loaded through capillary action of liquid **32** along the walls of the through-holes. To provide for wetting of the lower surface of platen **10**, the platen is lowered into reservoir
30
35

5 **34** and rotated, by torque applied through shaft **38**, or otherwise, through an angle typically on the order of a quarter revolution. Alternatively, platen **10** may be wetted and liquid **32** drawn into the microwells by immersing platen **10** into liquid **32** and tilting the platen about an axis in the plane of the platen.

10 **Stabilization with respect to capillary and evaporative liquid loss**

 In order to maintain the sample in liquid form in the respective microwells, evaporation of the liquid must be avoided. One method of avoiding evaporation is to provide an ambient atmospheric environment of 100% humidity. Among other methods that may be practiced to suppress evaporation, in accordance with an embodiment of the invention, a high molecular-weight fluid, such as various alcohols, for example, may be introduced on each end of the microwells thereby forming molecular monolayers or other thin layers to prevent evaporation of the liquid sample.

 Referring to FIG. 5, a cross-section of a portion of platen **10** is shown to include through-hole microwell **12**. In order to enhance capillary loading of the microwell and to prevent capillary outmigration of the sample liquid, exterior sections **40** of the microwell, adjacent to surfaces **14** and **16** of platen **10**, has a hydrophobic wall surface in accordance with a preferred embodiment of the invention, while the interior section **42** of the through-hole wall has a hydrophilic surface thereby preferentially attracting an aqueous liquid sample. Typically, the interior ~160 μm segment of the microwell may have a hydrophilic wall surface, while the hydrophobic layers on either end of the well are on the order of 20 μm in length. On loading the sample liquid into the microwells, typically 10% of the well, on either end, is left unfilled, and subsequent test samples in liquid form will rapidly diffuse to hydrophilic center of microwell thereby mixing with the liquid already present.

30

Optical interrogation

 Depending upon the application to which the present invention is applied, the result of the reaction of the first sample in liquid form with subsequently added analytes may be read out in a wide variety of manners known to persons skilled in the biological or biochemical arts. Readout systems may employ taggants of various sorts allowing

35

WO 99/34920

PCT/US99/00088

5 interrogation of the sample within the addressable microwell to determine whether a specified reaction has occurred. Some reactions may be interrogated optically, to include, without limitation, such optical methods as colorimetric or fluorometric methods, or resonant or non-resonant scattering methods, including Raman spectroscopic methods.

10 Referring now to FIG. 6, optical interrogation methods, of which the foregoing are but examples, may be implemented, in accordance with an embodiment of the invention by coupling a light beam 50 into through-hole 12 of platen 10 and detecting light 52 emergent from the opposite aperture of through-hole 12 by detectors 54 constituting detector array 56. Alternatively, light returned by scattering in the original direction can be collected and analyzed using standard optical techniques. In order to
15 optimize the signal-to-noise of the optical signal, the beam shape and through-hole volume are preferably matched. In accordance with a preferred embodiment of the invention, optical matching to a through-hole of cylindrical cross-section and of aspect ratio greater than one is achieved through a confocal optical geometry in which an initially collimated beam 50 is transformed by optical element 58 into a beam having a
20 diffraction limited focus at the center 60 of through-hole 12. The emergent optical beam 52 is collected and focussed onto detector array 56 by optical element 60. Superior optical sampling of the volume of the through-hole may be obtained if the through-hole has a rectangular cross-section, and if the optical radiation is guided by the walls of the through-hole in the manner of a waveguide. Optical element 58 and 60 may be lenses or
25 mirrors or combinations thereof as well known to persons skilled in the optical arts. Detector array 56 may be a charge-coupled device (CCD) array, for example, and, in one embodiment of the invention, a 1000 × 1000 element format is employed, with each through-hole imaged onto three elements 54 of the detector array. A window 63 may be disposed between platen 10 and detector array 56 and may be dried using standard
30 techniques if the assay is conducted in a humid ambient environment as discussed above. Alternatively, beam 50, coupled into through-hole 12 by coupling element 58 may be guided, in the manner of a guided wave through a waveguide, by the walls 62 of through-hole 12 in order to provide efficient interrogation of the sampled volume within the through-hole.

5 In some cases, where the material of platen 10 is not entirely opaque at the wavelengths of interrogating optical beam 50, wall 62 of through-hole 12 may be coated to prevent light leakage and cross-talk among the addressable sample volumes.

10 FIG. 7 shows a preferred embodiment of the present invention in which platen 10 is configured in the CD-ROM format described above, with interrogating optical source 50 capable of travel in radial direction 68 while platen 10 rotates about center 66. Optical detector array 56 may translate in conjunction with source 50, in accordance with an embodiment of the invention.

Continuous process analysis

15 Referring to FIG. 8, in accordance with an advantageous embodiment of the present invention, platen 10, which may be a flexible polymeric substance, for example, is conveyed in a direction 70 past an optical interrogation system comprising an optical source 72 and a detector array 74. Samples in liquid form may be loaded into through-holes 12 and advanced at a rate governed by the relevant reaction times so that a row 76
20 is interrogated optically at the period during which a specified indication is expected.

Mixing and Dilution

25 Referring now to Fig. 9, a cross-sectional view is shown of portions of a first platen 90 and a second platen 92 brought into proximity with each other in anticipation of processes performed in accordance with embodiments of the present invention for preparing, mixing, or diluting liquid samples. Through-holes 12 of platen 90 are shown as having been loaded with liquid samples 94 which may be identical across some specified subset of through-holes 12, or may be identical for the entire platen. Liquid sample 94, as shown schematically, may include cells or other targets 96 in solution
30 within a solvent 98.

Through-holes 12 of second platen 92 is shown as having been loaded with liquid samples 100 and 102 shown comprising one or more solvents or other agents. In particular, platen 92 may have been populated with a library of distinct compounds, each of which is to be exposed to target 96 of platen 90.

5 Fig. 10 shows platens **90** and **92** of Fig. 9 having been brought into contact with
one another, in such a manner as to allow through-holes of the respective platens to
register on a one-to-one basis. The mating of protrusions **8** with indentations **6** of
respective platens facilitates the registration of through-holes, and provides for the
mixing of the liquid sample contents of the respective through-holes. Thus, as shown,
10 half of targets **96** from samples **94** of first platen **90** have migrated to the solvent of
samples **100** and **102**. Mixing or dilution may be facilitated in this manner, either
through ordinary statistical diffusion, or by any method employed to facilitate mixing.
Mixing may be enhanced, for example, by the creation of thermal eddy currents and
turbulence induced by laser irradiation. Mixing rates have been found to be enhanced in
15 this way by more than an order of magnitude. Any other mixing techniques, including
acoustic perturbation or stirring of the samples with micropipettes, for example, are
within the scope of the present invention as described herein and as claimed in any
appended claims.

20 The number of platens **90** and **92** that may be stacked, in accordance with the
present invention, is not limited to two, as shown in Figs. 9 and 10 by way of example
only. Thus, the concentration of targets **96** in solvent **98** may be diluted to a specified
degree by stacking a corresponding number of platens with registered through-holes and
allowing migration of targets **96** throughout the liquid contained within the
corresponding sample volumes of the stack.

25

Transportation of biological samples

30 The perforated platen described herein in accordance an embodiment of the
present invention may be employed, for example, for shipping samples of a uniform
strain of cells to laboratories. In this application, the cells or other biological sample may
be introduced into the through-hole wells of the invention in aqueous or other liquid
suspension. The liquid carrier is then evaporated, allowing the cells or other biological
samples to form a coating, in the form of a chimney, of the walls of the plurality of
through-hole wells. The samples may then subsequently be resuspended by wetting and
further analytes may be introduced.

35 The described embodiments of the invention are intended to be merely exemplary
and numerous variations and modifications will be apparent to those skilled in the art.

WO 99/34920

PCT/US99/00088

5 All such variations and modifications are intended to be within the scope of the present invention as defined in the appended claims.

I CLAIM:

1. A method for selecting samples having specified properties from a library of samples, the method comprising:
 - a. providing a platen having two substantially parallel planar surfaces and a plurality of addressable through-holes disposed substantially perpendicularly to the planar surfaces;
 - b. loading a first sample in liquid form into at least one of the through-holes;
 - c. adding a second sample into the at least one of the through-holes for permitting reaction between the first sample and the second sample; and
 - d. characterizing the reaction in the through-hole in terms of the specified properties.
2. A method according to claim 1, wherein each through-hole is dimensioned so as to maintain a liquid sample therein by means of surface tension.
3. A method according to claim 1, wherein each through-hole has a volume less than 100 nanoliters.
4. A method according to claim 1, wherein the plurality of addressable through-holes has a density in excess of 108 per square meter.
5. A method according to claim 1, wherein the first sample in liquid form includes at least one of a target in solution and a target in suspension.
6. A method according to claim 2, wherein the at least one of a target in solution and a target in suspension includes a biological material.
7. A method according to claim 1, wherein the step of loading a first sample includes drawing the sample from a planar surface by capillary action.
8. A method according to claim 1, wherein the step of loading a first sample includes bringing the platen into contact with a reservoir of liquid and rotating the platen about an axis perpendicular to the surface of the reservoir.
9. A method according to claim 1, wherein the step of loading a first sample includes bringing the platen into contact with a reservoir of liquid and rotating the platen

about at least one of an axis perpendicular to the surface of the reservoir and an axis parallel to the surface of the reservoir.

10. A method according to claim 1, wherein the step of loading a first sample includes bringing the platen into contact with a reservoir of liquid and impelling the platen in a direction substantially perpendicular to the planar surfaces of the platen.
11. A method according to claim 1, further including maintaining a humid atmosphere for preventing evaporation of the first sample.
12. A method according to claim 1, further including coating the liquid sample with a monolayer for preventing evaporation of the first sample.
13. A method according to claim 1, wherein the step of characterizing the reaction in the through-hole in terms of the specified properties includes optically analyzing the sample.
14. A method for characterizing a plurality of liquid samples, the method comprising:
 - a. providing a platen having a set of through-holes, an inner layer of hydrophilic material and two outer layers of hydrophobic material coupled to opposite sides of the inner layer;
 - b. loading a specified liquid sample into each of a proper subset of the set of through-holes, wherein the layers of hydrophobic material prevent capillary outmigration of the samples; and
 - c. characterizing a property of the specified liquid sample.
15. A method according to claim 14, the step of characterizing a property of the specified liquid sample comprising:
 - a. illuminating at least one through-hole of the subset of the set of through-holes with optical radiation; and
 - b. analyzing the optical radiation emanating from the at least one through-hole.
16. A method for analyzing a plurality of liquid samples, the system comprising:
 - a. loading the liquid samples into a plurality of through-holes disposed in a platen, the platen having an inner layer of hydrophilic material and two outer layers of

hydrophobic material coupled to opposite sides of the inner layer, wherein the layers of hydrophobic material prevent capillary outmigration of the samples;

- b. illuminating at least one through-hole with optical radiation; and
- c. analyzing the optical radiation emanating from the at least one through-hole.

17. A method in accordance with claim 16, wherein the step of analyzing includes spectrally characterizing the optical radiation emanating from the at least one through-hole.

18. A method for preparing a plurality of combinations of members of a first set of samples in liquid form with members of a second set of samples in liquid form, the method comprising:

- a. providing a first perforated platen having through-holes and a second perforated platen having through-holes;
- b. loading a first set of samples in liquid form into the through-holes of the first perforated platen;
- c. loading a second set of samples in liquid form into the through-holes of the second perforated platen;
- d. registering the through-holes of the first perforated platen with the through-holes of the second perforated platen; and
- e. combining the first set of samples with the second set of samples.

19. A method according to claim 18, wherein the step of combining includes inertially injecting the first set of samples into the through-holes of the second perforated platen.

20. A method for mixing a plurality of liquid samples, the method comprising:

- a. loading a first set of liquid samples into a plurality of through-holes disposed in a first platen, the platen having a first substantially planar surface and a second substantially planar surface, the surfaces being substantially parallel to each other;

b. loading a second set of liquid samples into a plurality of through-holes disposed in a second platen, the platen having a first substantially planar surface and a second substantially planar surface, the surfaces being substantially parallel to each other;

c. disposing the first planar surface of the first platen in contact with the first planar surface of the second planar surface in such a manner that at least one through-hole of the first set is in registration with at least one through-hole of the second first set.

21. A method according to claim 20, wherein the first set of liquid samples includes a solute dissolved in a solvent and the second set of liquid samples includes a solvent, such that the concentration of solute in the first set of liquid samples is diluted upon performance of the step of disposing.

22. A method according to claim 20, further comprising:

d. mixing a liquid of the first set of liquid samples with a liquid of the second set of liquid samples.

23. A method according to claim 22, wherein the step of mixing includes inducing turbulence within the liquid by optical means.

24. A method according to claim 22, wherein the step of mixing includes inducing turbulence within the liquid by acoustic means.

25. A method according to claim 22, wherein the step of mixing includes inducing turbulence within the liquid by mechanical means.

26. A method for transporting biological samples, the method comprising:

a. providing a platen having a set of substantially cylindrical through-holes having walls;

b. loading the biological samples suspended in a liquid carrier into the through-holes; and

c. evaporating the liquid carrier for causing the biological samples to deposit on the walls of the through-holes.

27. A perforated platen having substantially parallel planar surfaces for manipulating liquid samples, the platen comprising:

a. an inner layer of hydrophilic material;

b. two outer layers of hydrophobic material coupled to opposite sides of the inner layer; and

c. through-holes for retaining the liquid samples, the through-holes traversing the inner layer and the two outer layers in a direction substantially perpendicular to the planar surfaces of the platen.

28. A system for analyzing a plurality of liquid samples, the system comprising:

a. a platen having two substantially parallel planar surfaces and a plurality of through-holes having apertures and walls, the platen having an inner layer of hydrophilic material and two outer layers of hydrophobic material coupled to opposite sides of the inner layer, wherein the layers of hydrophobic material prevent capillary outmigration of the samples;

b. a source of optical radiation for illuminating at least one through-hole along an optical axis; and

c. an optical arrangement for analyzing light emanating from the at least one through-hole.

29. A system according to claim 28, wherein the apertures of the plurality of through-holes are disposed on centers of a hexagonally close-packed lattice on the surface of the platen.

30. A system according to claim 28, wherein the apertures of the plurality of through-holes are disposed on centers of a rectangular lattice on the surface of the platen.

31. A system according to claim 28, wherein the through-holes have an aspect ratio of axial to transverse dimension of greater than 1.5.

32. A system according to claim 28, wherein the volume enclosed by the wall of each through-hole and the planes of the planar surfaces of the platen is less than 100 nanoliters.

33. A system according to claim 28, wherein the wall of each through-hole is in part hydrophilic and in part hydrophobic.

34. A system according to claim 28, wherein the wall of each through-hole comprises:

- a. a central hydrophilic segment; and
 - b. two hydrophobic segments such that one hydrophobic segment extends from the central hydrophilic segment to each planar surface of the platen.
35. A system according to claim 28, wherein the platen is a laminate having a central hydrophilic layer and two outer hydrophobic layers disposed on opposite sides of the central hydrophilic layer.
36. A system according to claim 28, wherein the platen is a metal.
37. A system according to claim 28, wherein the platen is a material selected from the group consisting of amorphous materials, ceramic, glass, quartz, and glassy carbon.
38. A system according to claim 28, wherein the platen is a polymeric material.
39. A system according to claim 28, wherein the walls of the plurality of through-holes are coated for allowing emission of light from the through-holes only at the planar surfaces of the platen.
40. A system according to claim 28, further including an advancement mechanism for translating the platen in a direction perpendicular to the optical axis.
41. A perforated platen having substantially parallel planar surfaces for manipulating distinct liquid samples, each sample having a volume less than 1 microliter, the platen comprising:
- a. an inner layer of hydrophilic material;
 - b. two outer layers of hydrophobic material coupled to opposite sides of the inner layer in such a manner as to isolate the distinct liquid samples from each other; and
 - c. a two-dimensional array of through-holes for retaining the distinct liquid samples, the through-holes each having a characteristic cross-sectional dimension of between 100 and 400 micrometers, the through-holes spaced on a two-dimensional grid with a center-to-center spacing between nearest neighbors of twice the characteristic cross-sectional dimension or less, each through-hole traversing the inner layer and the two outer layers in a direction substantially perpendicular to the planar surfaces of the platen,

wherein the platen has a substantially circular shape and includes a central aperture.

42. A system for analyzing a plurality of distinct liquid samples, the system comprising:

a. a platen having two substantially parallel planar surfaces and a two-dimensional array of through-holes, the platen having apertures and walls for retaining the distinct liquid samples in such a manner that the distinct liquid samples may not intermix, the through-holes each having a characteristic cross-sectional dimension of between 100 and 400 micrometers;

b. a source of optical radiation for illuminating a plurality of through-holes of the two-dimensional array; and

c. an optical arrangement including a detector array for separately analyzing light emanating from each of the plurality of illuminated through-holes.

43. A system according to claim 42, wherein the apertures of the plurality of through-holes are disposed on centers of a hexagonally close-packed lattice on the surface of the platen.

44. A system according to claim 42, wherein the apertures of the plurality of through-holes are disposed on centers of a rectangular lattice on the surface of the platen.

45. A system according to claim 42, wherein the volume enclosed by the wall of each through-hole and the planes of the planar surfaces of the platen is less than 100 nanoliters.

46. A system according to claim 42, wherein the wall of each through-hole is in part hydrophilic and in part hydrophobic.

47. A system according to claim 42, wherein the platen is a laminate having a central hydrophilic layer and two outer hydrophobic layers disposed on opposite sides of the central hydrophilic layer.

48. A system according to claim 42, wherein the platen is a metal.

49. A system according to claim 42, wherein the platen is a material selected from the group consisting of ceramic, glass, and quartz.

50. A system according to claim 42, wherein the platen is a polymeric material.
51. A system according to claim 42, wherein the walls of the plurality of through-holes are coated for allowing emission of light from the through-holes only at the planar surfaces of the platen.
52. A system according to claim 42, further including an advancement mechanism for translating the platen in a direction perpendicular to the optical axis.
53. A method for analyzing specified properties of a set of samples, the method comprising:
- a. providing a platen having two substantially parallel planar surfaces, an inner layer of hydrophilic material, two outer layers of hydrophobic material coupled to opposite sides of the inner layer, and a two-dimensional array of a plurality of addressable through-holes, the through-holes being disposed substantially perpendicularly to the planar surfaces;
 - b. loading a first sample into a first set of through-holes of the two-dimensional array, the first sample being a liquid;
 - c. retaining the first sample in the first set of through-holes by surface tension;
 - d. adding a second sample into a specified subset of through-holes, the specified subset of through-holes having at least one adjacent through-hole containing a sample other than the second sample, the specified subset of through-holes further coinciding with one of the first set of at least one of the through-holes thereby permitting a reaction between the first sample and the second sample, wherein the layers of hydrophobic material prevent capillary outmigration of the samples; and
 - e. characterizing the reaction in the specified subset of through-holes in terms of the specified properties.
54. A method according to claim 53, the method further comprising:
- f. illuminating a set of more than one of the plurality of through-holes with optical radiation; and

g. separately analyzing the optical radiation emanating from each through-hole of the set of more through-holes than one using an optical arrangement including a detector array.

55. A method in accordance with claim 53, wherein the step of analyzing includes spectrally characterizing the optical radiation emanating from each through-hole.

56. A method for analyzing specified properties of a set of substances, the method comprising:

a. providing a platen having two substantially parallel planar surfaces, an inner layer of hydrophilic material and two outer layers of hydrophobic material coupled to opposite sides of the inner layer, and a two-dimensional array of addressable through-holes;

b. retaining a set of distinct substances in respective through-holes of the array in such a manner that a first through-hole contains a first substance distinct from a second substance contained in an adjacent through-hole to the first through-hole;

c. adding a liquid into at least one of the through-holes containing a substance for permitting a reaction between the liquid and the substance; and

d. characterizing contents of distinct through-holes in terms of the specified properties.

57. A method according to claim 56, wherein the set of different substances includes a reagent.

58. A method according to claim 56, wherein the set of different substances include optical taggants.

59. A method according to claim 56, wherein the step of retaining the set of distinct substances further includes:

loading the set of distinct substances in one of liquid solution and suspension; and forming coatings of the distinct substances so as to retain the distinct substances on walls of the through-holes.

60. A method according to claim 56, wherein the step of adding a liquid includes resuspending the distinct substances in liquid by means of wetting.

61. A method according to claim 56, wherein the step of characterizing contents of distinct through-holes includes characterizing by optical methods.
62. A method according to claim 56, wherein the step of characterizing contents of distinct through-holes includes characterizing by fluorometric methods.
63. A platen for retaining biological samples, the platen comprising:
 - a. an inner layer of hydrophilic material and two outer layers of hydrophobic material coupled to opposite sides of the inner layer;
 - b. a two-dimensional array of addressable through-holes; and
 - c. a set of distinct substances in respective through-holes of the array.
64. A platen according to claim 63, wherein distinct substances of the set of distinct substances are coated on walls of the through-holes.
65. A platen according to claim 63, wherein distinct substances of the set of distinct substances are retained within through-holes of the platen by surface tension.

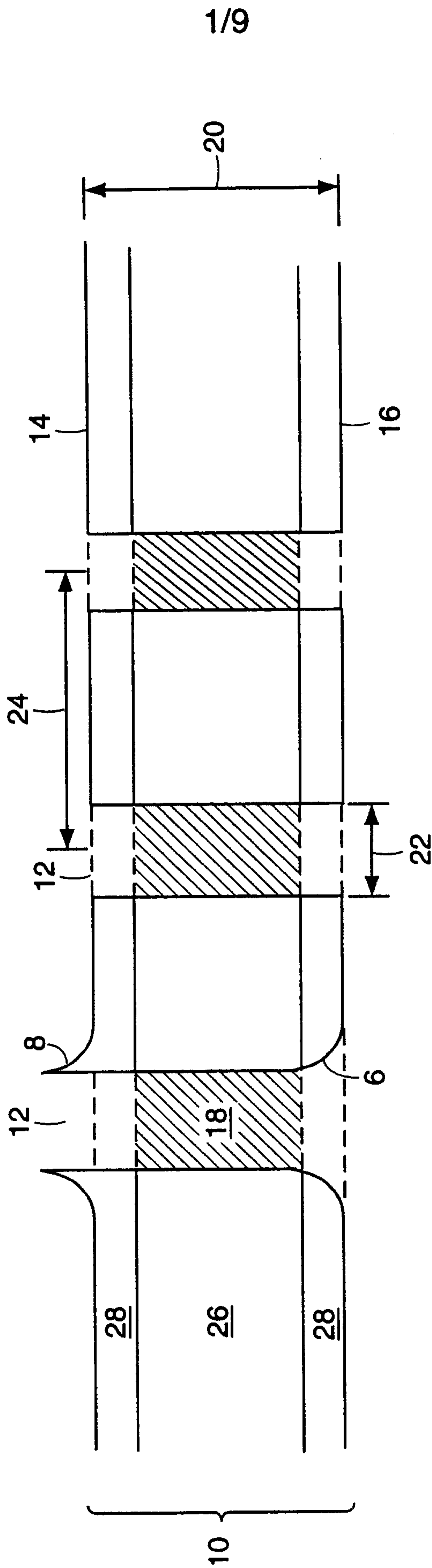

1/9

FIG. 1

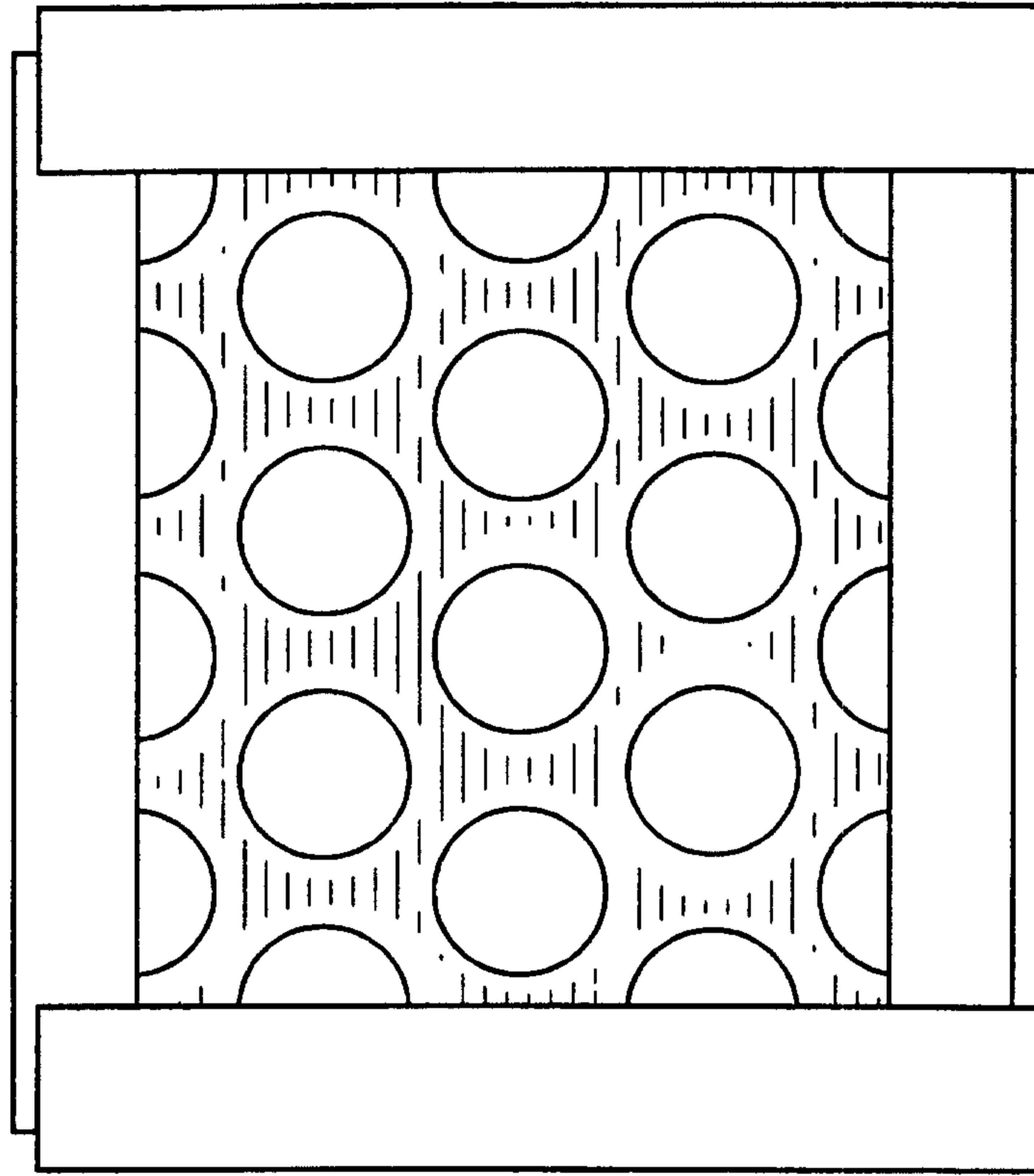

CLOSE PACKING

FIG. 2B

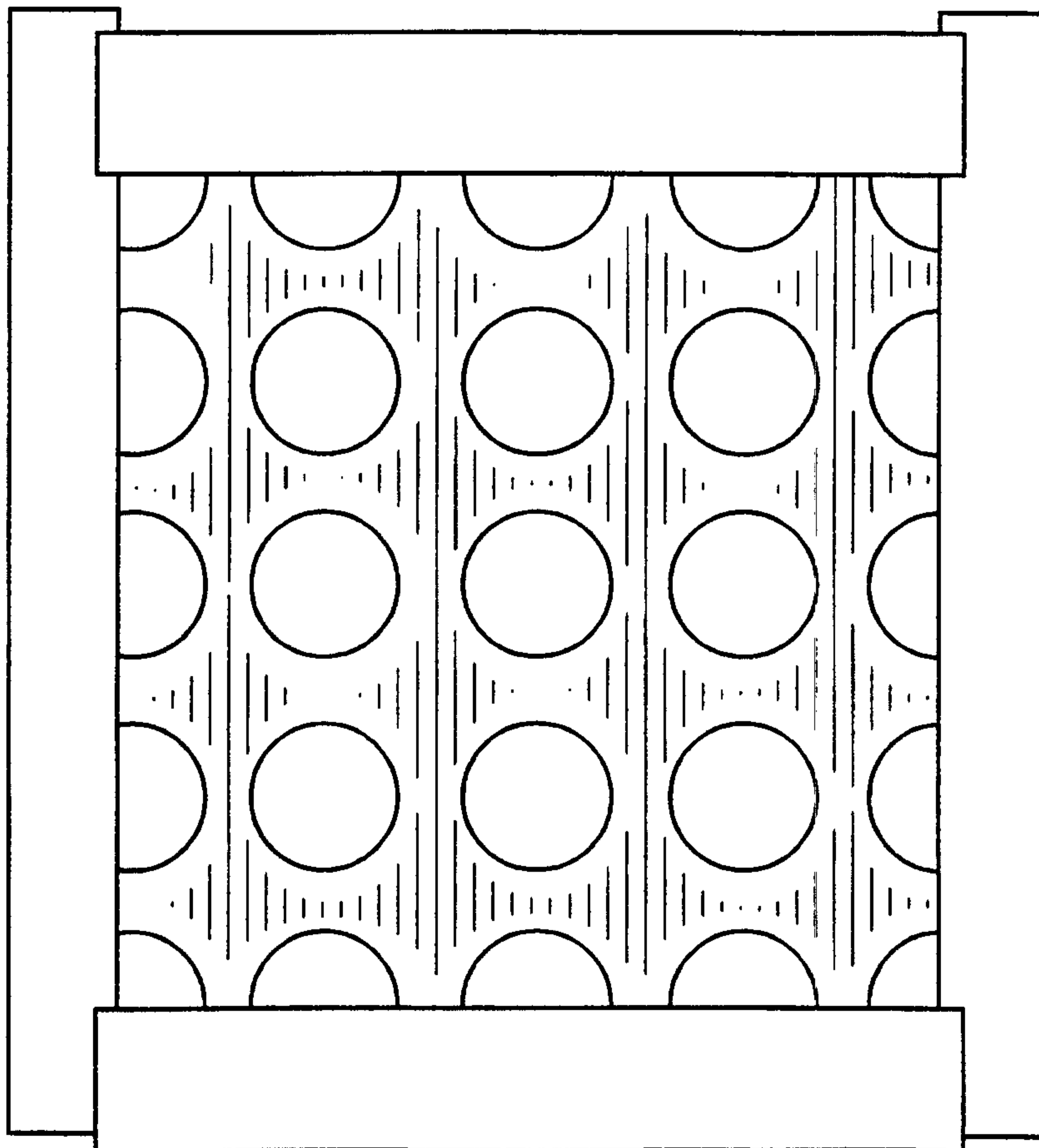

RECTANGULAR PACKING

FIG. 2A

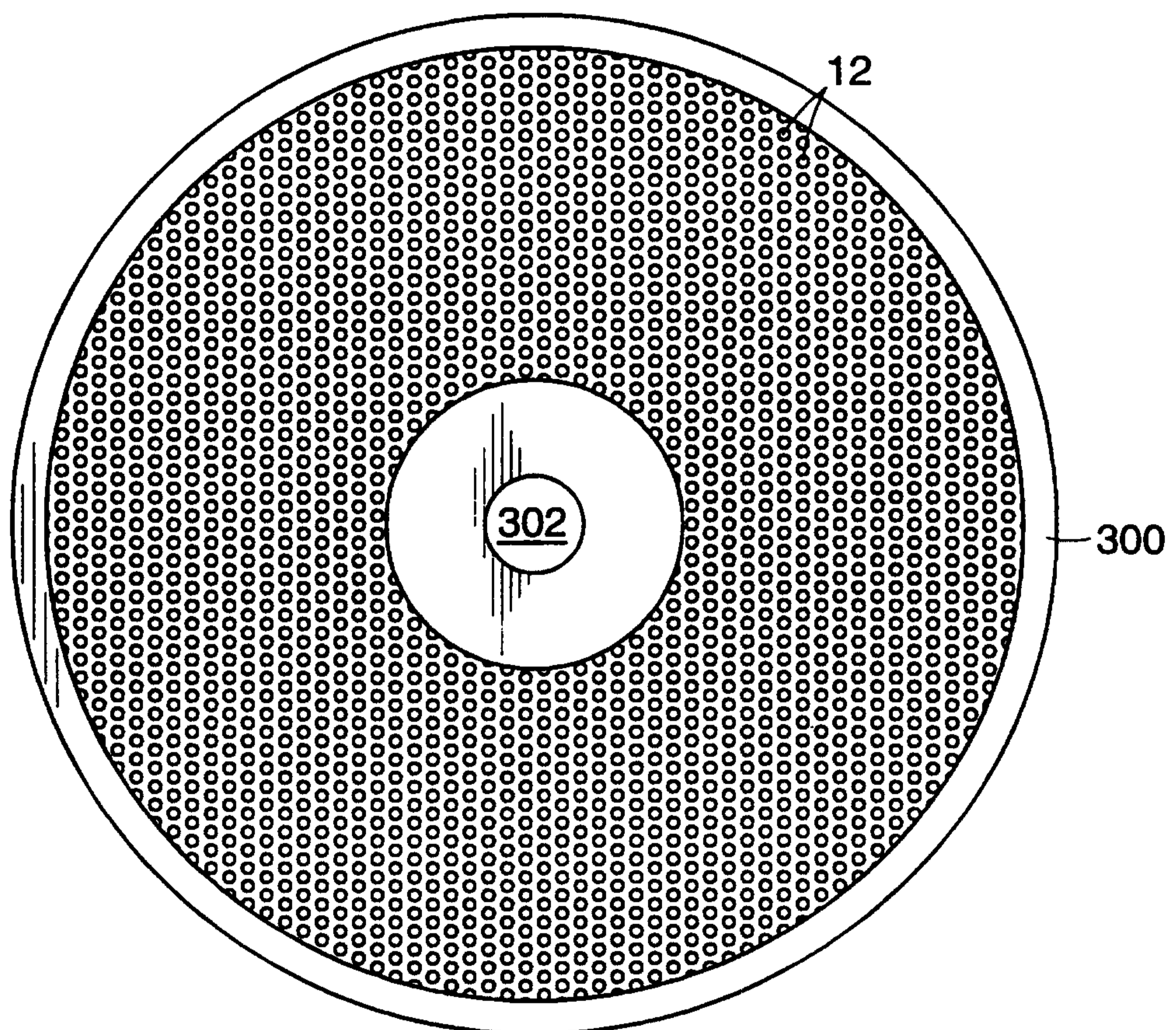

FIG. 3

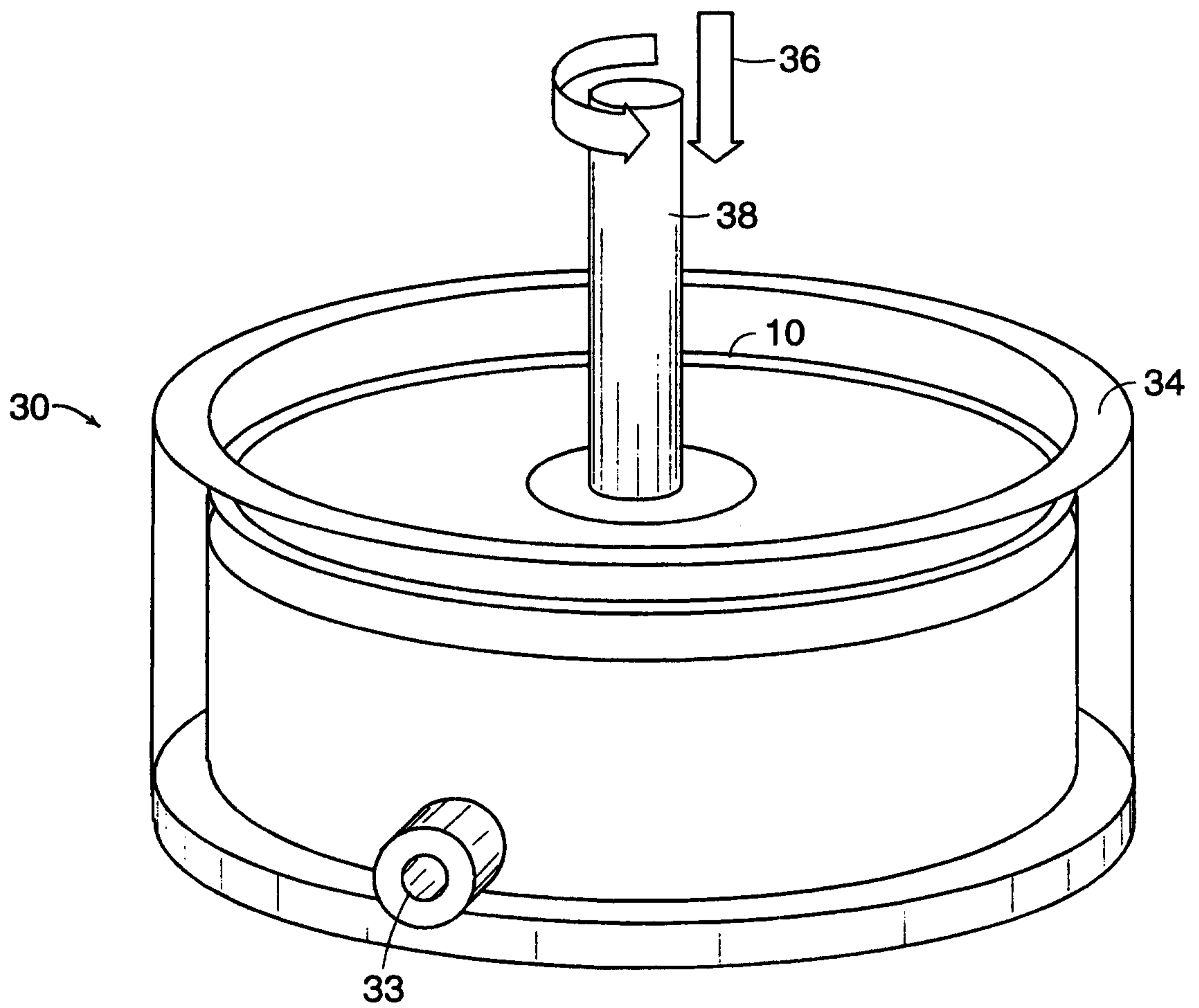

FIG. 4

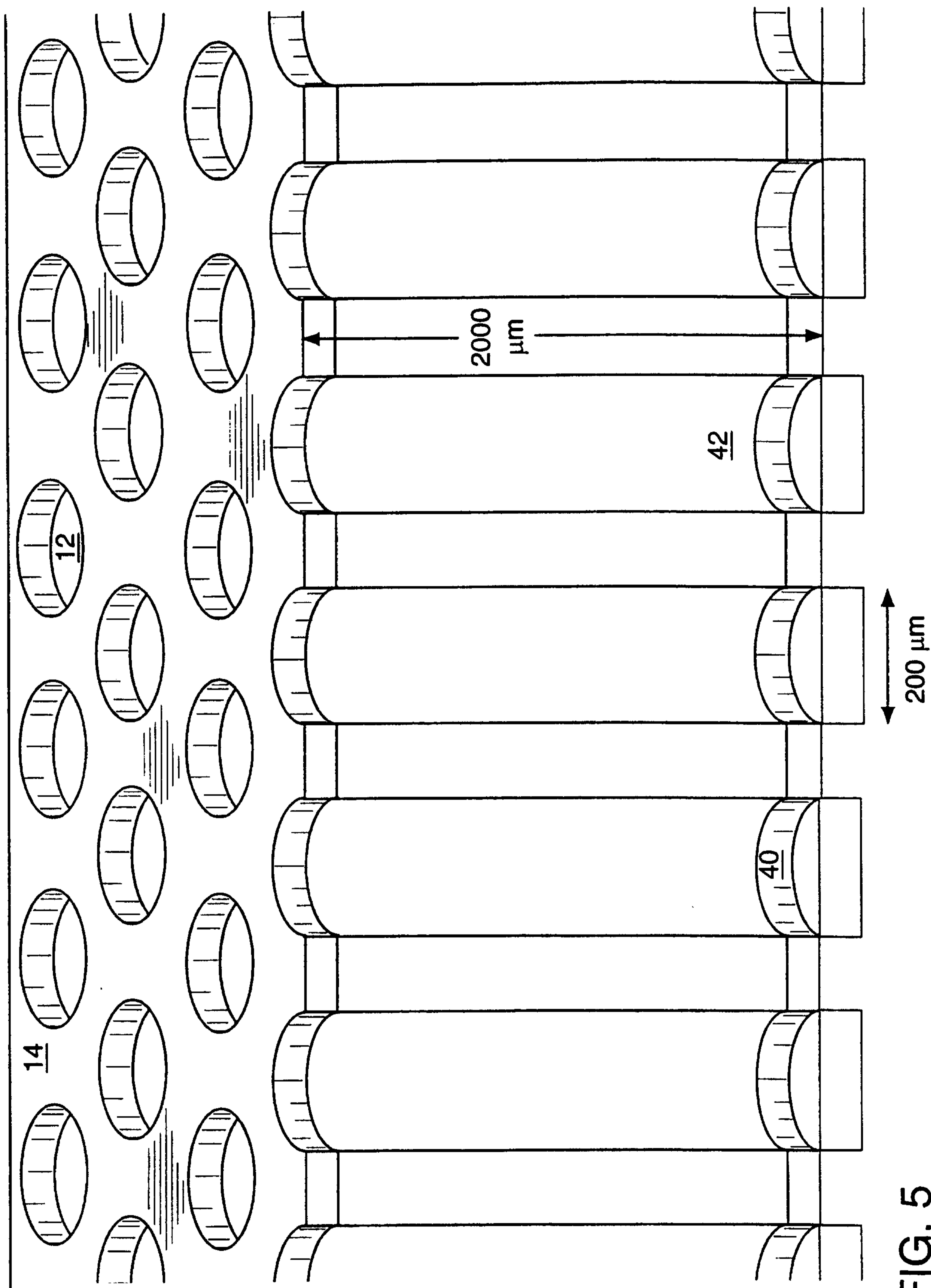

FIG. 5

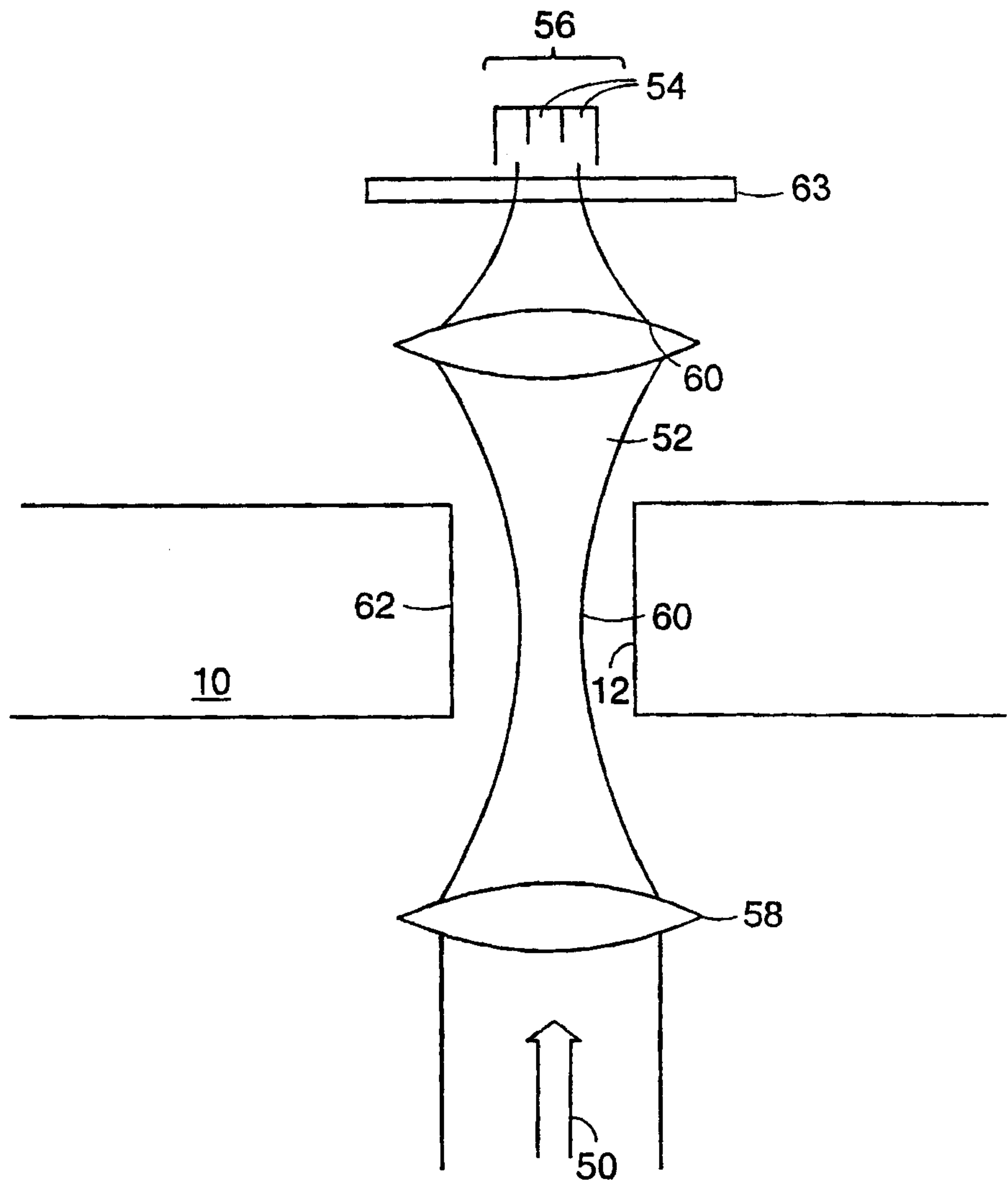

FIG. 6

7/9

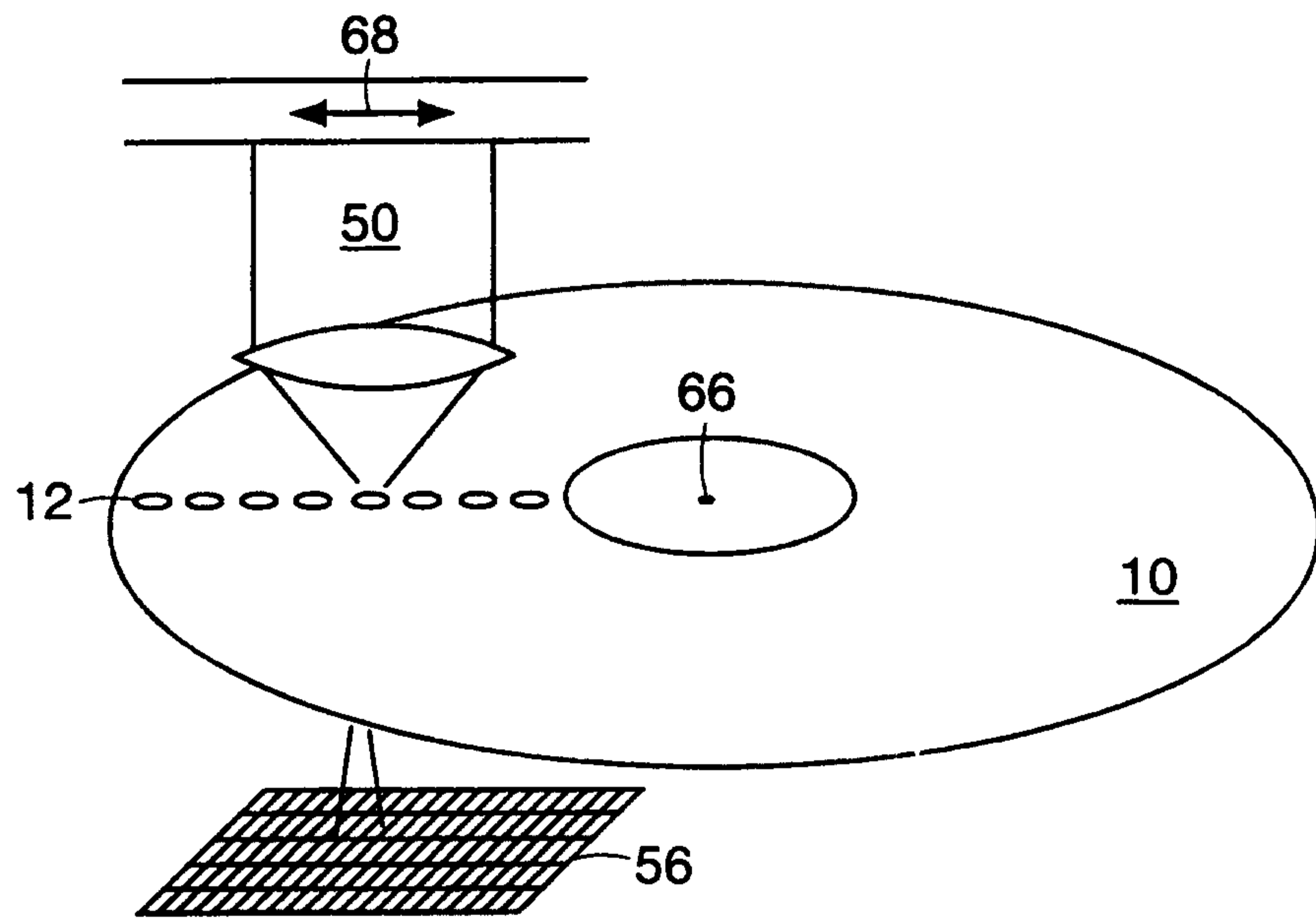

FIG. 7

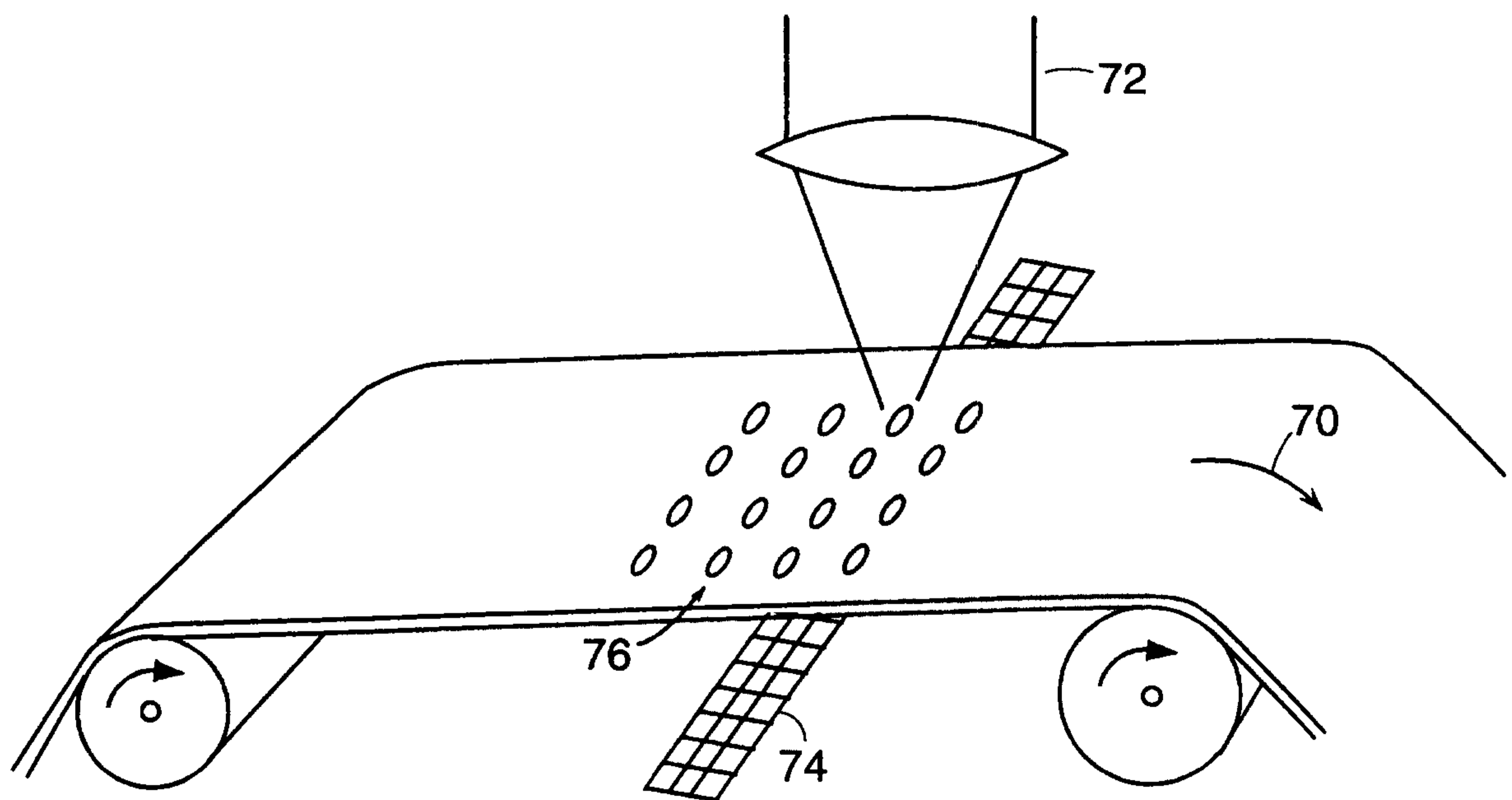

FIG. 8

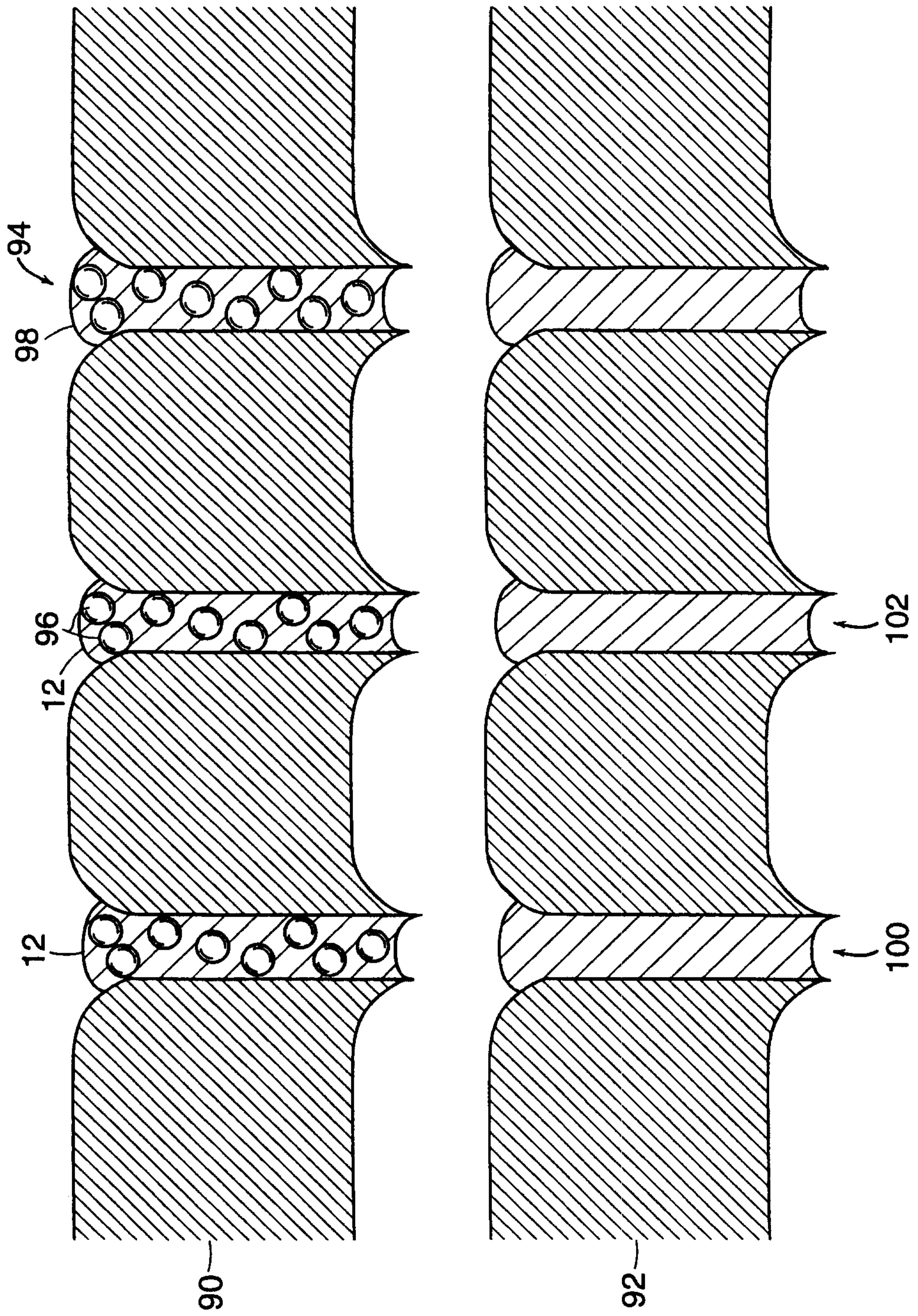

FIG. 9

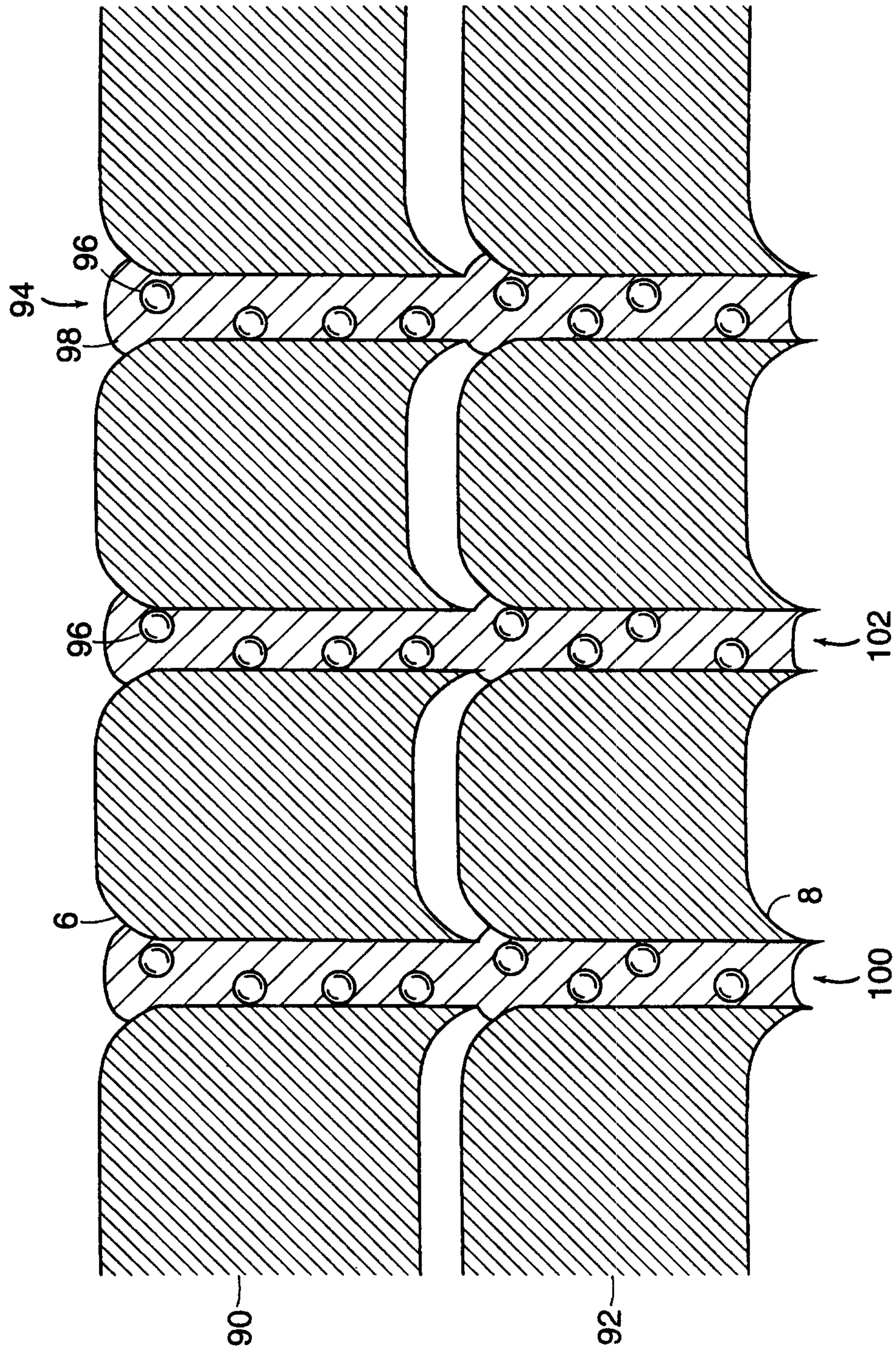

FIG. 10

