



(43) International Publication Date
4 July 2013 (04.07.20 13)

- (51) International Patent Classification:
A61B 77/77 (2006.01) A61B 17/34 (2006.01)
- (21) International Application Number:
PCT/EP2012/076600
- (22) International Filing Date:
21 December 2012 (21.12.2012)
- (25) Filing Language: English
- (26) Publication Language: English
- (30) Priority Data:
61/580,781 28 December 2011 (28.12.2011) US
- (71) Applicant: MATERIALISE N.V. [BE/BE]; Technologie-
laan 15, B-Leuven 3001 (BE).
- (72) Inventor: GEBELEN, Ben; Milsestraat 93, B-3053
Haasrode (BE).
- (74) Agents: PAEMEN, Liesbet, Rita, Johanna et al; De
Clercq & Partners, E. Gevaertdreef 10a, B-9830 Sint-
Martens-Latem (BE).

- (81) Designated States (unless otherwise indicated, for every
kind of national protection available): AE, AG, AL, AM,
AO, AT, AU, AZ, BA, BB, BG, BH, BN, BR, BW, BY,
BZ, CA, CH, CL, CN, CO, CR, CU, CZ, DE, DK, DM,
DO, DZ, EC, EE, EG, ES, FI, GB, GD, GE, GH, GM, GT,
HN, HR, HU, ID, IL, IN, IS, JP, KE, KG, KM, KN, KP,
KR, KZ, LA, LC, LK, LR, LS, LT, LU, LY, MA, MD,
ME, MG, MK, MN, MW, MX, MY, MZ, NA, NG, NI,
NO, NZ, OM, PA, PE, PG, PH, PL, PT, QA, RO, RS, RU,
RW, SC, SD, SE, SG, SK, SL, SM, ST, SV, SY, TH, TJ,
TM, TN, TR, TT, TZ, UA, UG, US, UZ, VC, VN, ZA,
ZM, ZW.
- (84) Designated States (unless otherwise indicated, for every
kind of regional protection available): ARIPO (BW, GH,
GM, KE, LR, LS, MW, MZ, NA, RW, SD, SL, SZ, TZ,
UG, ZM, ZW), Eurasian (AM, AZ, BY, KG, KZ, RU, TJ,
TM), European (AL, AT, BE, BG, CH, CY, CZ, DE, DK,
EE, ES, FI, FR, GB, GR, HR, HU, IE, IS, IT, LT, LU, LV,
MC, MK, MT, NL, NO, PL, PT, RO, RS, SE, SI, SK, SM,
TR), OAPI (BF, BJ, CF, CG, CI, CM, GA, GN, GQ, GW,
ML, MR, NE, SN, TD, TG).

[Continued on nextpage]

(54) Title: APPARATUS FOR INTRODUCING AN ANCHORING DEVICE

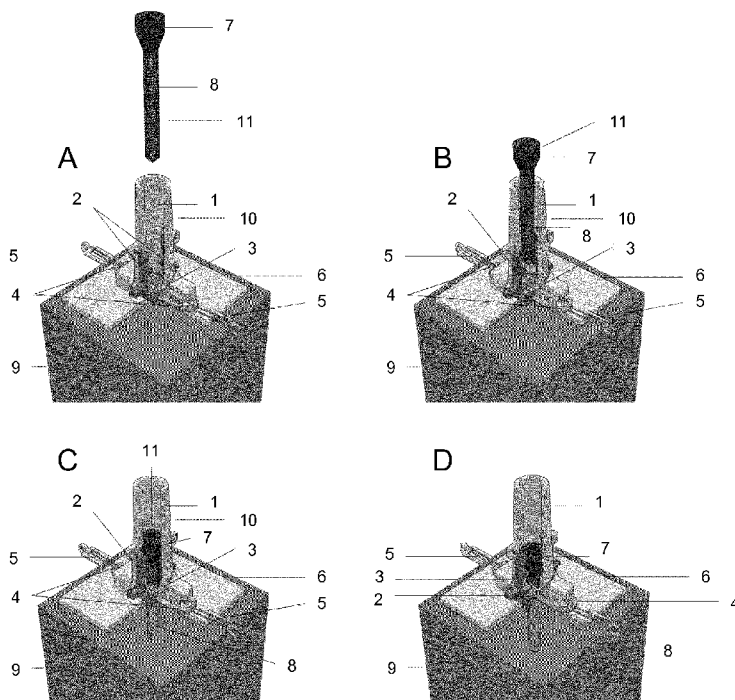

Figure 1

(57) Abstract: The application provides an apparatus for introducing an anchoring device into an object, said anchoring device having a head and an elongated body, said apparatus comprising an introducer shaft configured to engage the head of the anchoring device; and a guide system positioned, at least in part, inside said introducer shaft, wherein said guide system is configured to such that the anchoring device is prevented from passing through the introducer shaft unless the anchoring device passes through the guide system according to a predefined axis.

WO 2013/098232 A1

Declarations under Rule 4.17:

— *of inventorship (Rule 4.17(iv))*

Published:

— *with international search report (Art. 21(3))*

— *before the expiration of the time limit for amending the claims and to be republished in the event of receipt of amendments (Rule 48.2(h))*

APPARATUS FOR INTRODUCING AN ANCHORING DEVICE

FIELD OF THE INVENTION

5 The application relates to an apparatus for introducing anchoring devices into an object and methods for manufacturing and use thereof. Specifically, the application provides an apparatus which has an introducer shaft and a guide system which prevents the anchoring device from passing through the introducer shaft and into the object unless the anchoring device passes through according to a predefined axis.

10 BACKGROUND

Guides can be used to accurately introduce anchoring devices such as screws or nails into various objects. One important example of this is the use of surgical guides during orthopedic procedures. These surgical guides can be made from a pre-operative plan formed from a scan or image of the patient and rely on the matching of subcutaneous anatomic features for correct positioning. These types of surgical guides are often used in surgery of the spine, hip, knee or radius, but also other types of surgery are available.

20 Current surgical guides typically have a uniform cylindrical shaft having a diameter large enough to accommodate the portion of the anchoring device with the largest diameter, generally the head of the anchoring device. This diameter is generally constant along the entire axis of the cylindrical shaft. Such a shaft does not, however, accommodate for the fact that the diameter of the body of the anchoring device is generally smaller than the diameter of the head of the anchoring device. This difference in diameter can lead to unwanted movement of the anchoring device as it passes through the shaft. This movement reduces the accuracy by which the final position of the anchoring device can be defined.

25 In planning and executing a surgical procedure, this accuracy becomes particularly relevant. Improved medical imaging techniques and new processing techniques of these images allow a surgeon to determine regions in which the anchoring devices should and should not be inserted. This allows for precise placement of the anchoring device for a particular patient. Accordingly, there is a need for improved guides which provide for the accurate placement of anchoring devices.

SUMMARY OF THE INVENTION

The application relates to guides for introducing anchoring devices and methods for manufacturing thereof.

5 Provided herein is an apparatus for introducing an anchoring device having a head and an elongated body, wherein said head has a larger cross section compared to said elongated body, into an object, the apparatus comprising:

a. an introducer shaft configured to engage with the head of the anchoring device; and

10 b. a guide system, positioned at least in part inside said introducer shaft; wherein said guide system is configured to engage with part of said anchoring device such that the anchoring device is prevented from passing through the introducer shaft unless the anchoring device passes through the guide system according to a predefined axis.

15 Also provided herein is a combination of an apparatus as described herein and an anchoring device for use therewith, having an elongated body and a head, wherein said head has a larger cross section compared to said elongated body.

 More particularly the apparatus described herein is configured such that, as the anchoring device passes through the apparatus, the introducer shaft engages with the
20 head of the anchoring device and the guide system engages with the elongated body of the anchoring device such that the anchoring device is prevented from passing through the introducer shaft unless the anchoring device passes through the guide system according to a predefined axis.

 More particularly, the guide system comprises two or more guiding parts movable
25 with respect to the introducer shaft from at least a first position to at least a second position, which are configured to engage with the elongated body of the anchoring device, and wherein said first position defines the passage of the elongated body and said second position defines the passage of the head of the anchoring device through the guide system according to a predetermined axis. More particularly, the guide system
30 comprises a locking mechanism configured to lock the movable guiding parts into the first position, and wherein the locking mechanism is released when the head of the anchoring device passes a certain release point along the longitudinal axis of the introducer shaft.

According to a particular embodiment an apparatus is provided wherein the movable guiding parts consist of a first slide arm, the first slide arm comprising two or more sliding elements which allow for movement along a uniform axis and which provide an opening in the first slide arm sized to engage with the elongated body of the anchoring device. More particularly, the locking mechanism comprises one or more pivot arms, wherein said pivot arms are releasably coupled to the movable guiding parts, wherein the pivot arms can rotate with respect to the introducer shaft from at least a first position to at least a second position, wherein said pivot arms are configured such that in said first position the pivot arms lock the movable guiding parts into their said first position, in said second position the pivot arms release the movable guiding parts, and the pivot arms are pushed from said first position to said second position by the head of the anchoring device as it passes the release point along the longitudinal axis of the introducer shaft. More particularly, the pivot arms are spaced equally along the circumference of the introducer shaft.

According to a particular embodiment an apparatus as described herein is provided wherein the locking mechanism comprises a second slide arm, the second slide arm comprising one or more sliding elements allowing the movement along a uniform axis, the slide elements being releasably coupled to the movable guiding parts, wherein the slide elements can move with respect to the introducer shaft from at least a first position to at least a second position, wherein in said first position the slide elements lock the movable guiding parts into their said first position, wherein in said second position the slide elements release the movable guiding parts, and wherein the slide elements are pushed from said first position to said second position by the head of the anchoring device as it passes the release point along the longitudinal axis of the introducer shaft.

According to a particular embodiment an apparatus is provided wherein the locking mechanism comprises two or more pivot arms, each pivot arm rigidly attached to one of the two or more movable guiding parts, wherein the pivot arms can rotate with respect to the introducer shaft from at least a first position to at least a second position, wherein in said first position the pivot arms lock the movable guiding parts into their said first position, wherein in said second position the pivot arms bring the movable guiding parts into their said second position, wherein the pivot arms engage with the head of the anchoring device, and wherein the rotational axes of the pivot arms cross the longitudinal axis of the introducer shaft at the release point, such that the head of the

anchoring device and the elongated body of the anchoring device push the pivot arms and the movable guiding parts in their respective first positions as the anchoring device passes through the apparatus and while the head of the anchoring device has not yet passed the release point. More particularly, the pivot arms are spaced equally along the circumference of the introducer shaft.

More particularly the apparatus as described herein further comprises at least one resilient device, such as a spring, which is attached to the movable guiding parts. In particular embodiments, the resilient device is configured to push or pull the movable guiding parts into their first position and the head of the anchoring device pushes the movable guiding parts into their second position as it passes them. Alternatively, the resilient device is configured to push or pull the movable guiding parts into their second position when they are released by the locking mechanism.

According to a particular embodiment an apparatus is provided as described herein wherein the guiding system comprises at least one resilient device, such as a spring, which is attached to the locking mechanism. More particularly, the resilient device is configured to push or pull the locking mechanism into the locked position.

According to a particular embodiment an apparatus is provided as described herein wherein the introducer shaft has at least the same length as the anchoring device.

According to a particular embodiment an apparatus is provided wherein said object is a body part of a patient and the predefined axis is determined through patient-specific pre-operative planning.

According to a particular embodiment an apparatus is provided as described herein wherein the apparatus further comprises a base plate.

According to a particular embodiment an apparatus is provided as described herein wherein the apparatus is an off-the-shelf device that can be assembled to a base plate.

Particularly, the base plate as used in the embodiments provided herein has a patient-specific surface.

Particular embodiments further provide an apparatus for introducing an anchoring device comprising a head and an elongated shaft into an object such as, but not limited to a body part, the apparatus comprising an introducer shaft; and a guide system which engages with said anchoring device, wherein at least part of the guide is inside of the introducer shaft and wherein the guide system ensures that the anchoring

device is prevented from passing through the introducer shaft unless the anchoring device passes through the guide according to a predefined axis.

More particularly, the apparatus as provided herein comprises an introducer shaft and a guide system comprised at least in part inside of the introducer shaft, whereby the
5 guide system comprising two or more parts is movable with respect to the introducer shaft from at least a first position to at least a second position. During the passage of the anchoring device, the two or more moveable parts of the guide system can engage with the anchoring device simultaneously in at least two different cross-sections of the longitudinal axis of the anchoring device, whereby the first and second position are such
10 that said first position defines the passage of the longitudinal shaft and said second position defines the passage of the head of said anchoring device through the guide system according to a predetermined axis.

In particular embodiments, it is provided that the movable parts configured to push the anchoring device into the predetermined path are configured not to be able to move
15 until the head of the anchoring device passes a certain point along the longitudinal axis of the introducer shaft.

In particular embodiments of the apparatus as provided herein, the introducer shaft has the same as the length as the anchoring device.

In a particular embodiment, the guide system of the apparatus provided herein
20 comprises:

- at least two pivot arms (2), wherein said pivot arms are configured to engage the anchoring device inside of the introducer shaft in at least two points; and
 - a slide arm releasably coupled to the at least two pivot arms, the slide arm comprising one or more sliding elements which allow for movement along a
25 uniform axis and which provide an opening in the slide arm;
- wherein the opening in the slide arm is configured to engage the body of the anchoring device inside of the introducer shaft in at least two points such that the anchoring device passes through the introducer shaft according to a predefined axis and wherein movement of the head of the anchoring device through the pivot
30 arms allows the movement of the one or more sliding elements allowing passage of the head of the anchoring device through the slide arm.

In particular embodiments, the apparatus further comprises at least one resilient device attached to each of the one or more sliding elements.

In particular embodiments of the apparatus, the pivot arms are equally spaced throughout the introducer shaft.

In further particular embodiments, the pivot arms are attached to a resilient device.

In yet further embodiments, the resilient device attached to the slide elements
5 and/or the pivot arms, is a spring.

In a particular embodiment, the apparatus comprises a guide system which comprises a first and a second slide arm, wherein the second slide arm is releasably coupled to the first slide arm, each slide comprising one or more sliding elements which
10 allow for movement along a uniform axis and which provides an opening in the slide arm; wherein the opening in the first slide arm is configured to engage the body of the anchoring device inside of the introducer shaft in at least two points such that the body of the anchoring device passes through the slide arm according to a predefined axis;
15 and wherein movement of the head of the anchoring device through the first slide arm allows the movement of the one or more sliding elements of the second slide arm allowing passage of the head of the anchoring device.

In a particular embodiment, the apparatus as described herein comprises a guiding system comprising two or more pivot arms, wherein said pivot arms can engage with
20 said anchoring device simultaneously at at least two different cross-sections of the longitudinal axis of the anchoring device such that, when an anchoring device is inserted, the body of the anchoring device passes through the introducer shaft according to a predefined axis and that the head of the anchoring device is prevented from passing through the pivot arms unless the anchoring device passes through the pivot arms
25 according to said predefined axis.

In specific embodiments the apparatus as provided herein having one or more of the features described above is used for the introduction of an anchoring device into a subject and, and the predefined axis is determined through patient-specific pre-operative
30 planning.

In further specific embodiments, the apparatus as provided herein further comprises a base plate, typically attached to the introducer shaft.

This base plate may have a surface which is specific for the object in which the anchoring device is to be introduced. Where the object is a body part of a patient, the surface may be a patient-specific surface.

Also provided herein are combinations of the apparatus provided herein and one or
5 more anchoring devices suitable for use therewith. More particularly the anchoring device has an elongated body and a head of which the diameter is greater than that of the elongated body.

Also provided herein are methods of introducing an anchoring device along a
10 predefined axis in an object.

In particular embodiments, said methods comprise:

- a) Determining the proper axis for introduction of said anchoring device in said object
- b) Positioning an apparatus as provided herein, comprising an introducer shaft
15 and a guide system comprised at least in part therein, which upon engagement with the anchoring device ensure that the anchoring device is passed through the apparatus according to a specific axis, such that said specific axis corresponds to the axis determined in step (a).
- c) Inserting an anchoring device into the introducer shaft of said apparatus
- d) Passing said anchoring device through said apparatus; and
20
- e) Removing said apparatus from said object.

In further particular embodiments, said methods comprise:

- a) Obtaining a digital scan of said object
- b) Determining through planning the proper axis for introduction of said
25 anchoring device,
- c) Positioning the apparatus as provided herein, comprising an introducer shaft and a guide system comprised at least in part therein, which upon engagement with the anchoring device ensure that the anchoring device is
30 passed through the apparatus according to a specific axis, such that said specific axis corresponds to the axis determined in step (a).
- d) Inserting an anchoring device into the introducer shaft of said apparatus;
- e) Passing said anchoring device through said guiding system of said apparatus
- f) Removing said apparatus from said object.

In particular embodiments, said object is a body part.

Also provided herein are methods of manufacturing the apparatuses as described herein. In particular embodiments, the methods comprise:

- 5 a) determining the features of the anchoring device comprising a head and an elongated shaft
- b) designing a device comprising
an introducer shaft and a guide system comprised at least in part inside of the
introducer shaft, wherein said guide system is configured to engage with part of
10 said anchoring device such that the anchoring device is prevented from passing through the introducer shaft unless the anchoring device passes through the guide system according to a predefined axis
- c) producing said apparatus based on the design obtained in step b).

15 In particular embodiments, the design of the device comprises designing the features as described for the embodiments described above, which ensure that the anchoring device passes through the apparatus according to a predefined axis.

In particular embodiments, the device is manufactured by additive manufacturing.

In further particular embodiments, the apparatus is used for introducing an
20 anchoring device into a body part and comprises a patient-specific base plate and said method comprises the steps of:

- a) Obtaining digital scan of said body part
- b) Determining through planning the proper axis for introduction of said anchoring device in said body part
- 25 c) Identifying the surface of the body part suitable for positioning of the apparatus
- d) Designing an introducer shaft and a guide system comprised at least in part inside of the introducer shaft, whereby the guide system comprising two or more parts movable with respect to the introducer shaft from at least a first position to at least a second position. The two or more moveable parts of the guide system
30 can engage with the anchoring device simultaneously at at least two different cross-sections of the longitudinal axis of the anchoring device and the first and second position are such that said first position defines the passage of the longitudinal shaft and said second position defines the passage of the head of said anchoring device through the guide system according to said proper axis

- e) Designing a base plate having a patient-specific surface, corresponding to the surface identified in step c)
- f) Producing the apparatus comprising said introducer shaft and guide system and said base plate based on steps d) and e).

5

BRIEF DESCRIPTION OF THE DRAWINGS

The following description of the figures of specific embodiments as provided herein is merely exemplary in nature and is not intended to limit the present teachings, their application or uses. Throughout the drawings, corresponding reference numerals indicate like or corresponding parts and features.

10

Figure 1 Figures 1A - 1K illustrate an embodiment of the apparatus (10) as envisaged herein for introducing an anchoring device (11). The apparatus has a guide system which comprises pivot arms (2) and a slide arm (4).

15 **Figure 2** Figures 2A-C illustrate a further embodiment of the apparatus for introducing an anchoring device (11). The apparatus has a guide system which comprises two slide arms (29).

Figure 3 Figures 3A-3E illustrate a further embodiment of the apparatus for introducing an anchoring device (11), wherein the introducer shaft (31) is connected to a base plate (34). The apparatus further has a guide system which comprises pivot arms (32). In figure 3E the base-plate has a patient-specific surface.

20

DETAILED DESCRIPTION

The application provides particular embodiments but the teachings disclosed herein are not limited thereto.

25

As used herein, the singular forms "a", "an", and "the" include both singular and plural referents unless the context clearly dictates otherwise.

The terms "comprising", "comprises" and "comprised of" as used herein are synonymous with "including", "includes" or "containing", "contains", and are inclusive or open-ended and do not exclude additional, non-recited members, elements or method steps. The terms "comprising", "comprises" and "comprised of" when referring to recited members, elements or method steps also include embodiments which "consist of said recited members, elements or method steps."

30

Furthermore, the terms first, second, third and the like in the description, are used for distinguishing between similar elements and not necessarily for describing a sequential or chronological order, unless specified. It is to be understood that the terms so used are interchangeable under appropriate circumstances and that the
5 embodiments described herein are capable of operation in other sequences than described or illustrated herein.

All documents cited in the present specification are hereby incorporated by reference in their entirety.

Unless otherwise defined, all terms used in herein, including technical and
10 scientific terms, have the meaning as commonly understood by one of ordinary skill in the art to which this application belongs. By means of further guidance, definitions for the terms used in the description are included to better appreciate the teaching as described herein. The terms or definitions used herein are provided solely to aid in the understanding of the different embodiments.

15 Reference throughout this specification to "one embodiment" or "an embodiment" means that a particular feature, structure or characteristic described in connection with the embodiment is included in at least one embodiment of the application. Thus, appearances of the phrases "in one embodiment" or "in an embodiment" in various
20 places throughout this specification are not necessarily all referring to the same embodiment, but may. Furthermore, the particular features, structures or characteristics may be combined in any suitable manner, as would be apparent to a person skilled in the art from this disclosure, in one or more embodiments. Furthermore, while some embodiments described herein include some but not other features included in other
25 embodiments, combinations of features of different embodiments are meant to be within the scope of the invention, and form different embodiments, as would be understood by those in the art.

Provided herein is an apparatus for introducing an anchoring device into an object. The apparatus is particularly suited for precise placement of an anchoring device
30 in a particular position in an object. The object may be any type of object which requires attachment of an anchoring device, including, but not limited to mechanical anchoring devices or fasteners for use in construction, automotive, aviation, appliances, agricultural machinery, commercial construction, infrastructure, electronic and/or medical industry.

In particular embodiments the apparatus as envisaged herein is an apparatus for introducing an anchoring device into a body part of a subject. The apparatus is particularly suited for precise placement of an anchoring device in a particular patient, thereby avoiding regions that have been determined during pre-operative planning to be unsuitable for anchoring devices. More particularly, the apparatus is devised to allow the anchoring device to pass through the entirety of the introducer shaft, such that the anchoring device can be fully introduced into the subject. After use, the apparatus can simply be lifted off of the subject, thereby improving the efficiency of introducing the anchoring devices and leaving the previously introduced anchoring devices undisturbed.

In accordance with particular embodiments described herein, there is provided an apparatus for introducing an anchoring device. In a particular embodiment, the apparatus has an introducer shaft and a guide system which is configured to engage with the anchoring device so as to ensure the passage of the anchoring device according to a predefined axis. Typically, engagement with the anchoring device is ensured by the fact that the device is configured to contact at least two points on the anchoring device. More particularly said points are opposing points (in a transverse section of the anchoring device). This ensures that the contact points maintain the correct positioning of the anchoring device within the apparatus. In particular embodiments, the guide system engages with the anchoring device by contacting in more than two points, such as four points (arranged in a cross, in a transverse section) or such as by forming an opening which spans most of the contour of the anchoring device.

At least part of the guiding system of the devices provided herein is present inside of the introducer shaft such that the anchoring device is prevented from passing completely through the introducer shaft unless the anchoring device passes through the guide according to a predefined axis.

As used herein, the term anchoring device typically refers to fastening means including, but not limited to, screws, nails, posts, rods, pins, and the like. In particular, an anchoring device is envisaged wherein at least one portion of the anchoring device has a diameter or cross section that is larger than the remainder of the anchoring device. For example, in Fig. 1A, the screw (11) has a head (7) that has a greater diameter than the elongated body of the screw (8). More particularly, the portion of the anchoring device having a larger diameter or cross-section is provided with means allowing connection

with a fastening tool, whereas the portion of the anchoring device having a smaller diameter is according to a particular embodiment provided with means, such as a thread, allowing the actual anchoring of the device.

More particularly, the apparatus as provided herein comprises an introducer shaft
5 and a guide system comprised at least in part inside of the introducer shaft, whereby the
guide system comprises two or more parts movable with respect to the introducer shaft.
In particular embodiments, the introducer shaft and the guide system are configured to
engage with the anchoring device when introduced therein simultaneously in at least two
10 different cross-sections along the longitudinal axis of the anchoring device (more
particularly at the head and the body of the anchoring device, respectively) such that the
anchoring device passes through the apparatus according to a predefined axis. In further
particular embodiments the two or more moveable parts are configured to move from at
least a first to at least a second position and the first and second position are such that
15 said first position defines the passage of the longitudinal shaft and said second position
defines the passage of the head of said anchoring device through the guide system
according to a predetermined axis. More particularly it is envisaged that one or more of
the moveable parts is releasably coupled to a second moveable part. Typically, the
moveable parts are configured such that a first moveable part prevents the movement of
20 a second moveable part until the head of the anchoring device passes a certain point on
said first moveable part.

Optionally, the moveable parts are coupled to a resilient device which determines
the movement from a first to a second position.

Different embodiments for the guide system are envisaged and will be described
25 hereafter.

Figures 1A - 1K illustrate an embodiment of the apparatus (10) for introducing an
anchoring device as provided herein. With respect to Figure 1A, in one embodiment, the
introducer shaft (1) is connected to a base plate (6). The apparatus further has a guide
system which comprises one or more pivot arm(s) (2) and a releasably coupled slide
30 arm (4). The pivot arm (2) is engaged by a resilient device (3). Likewise, the slide arm (4)
is engaged by a resilient device (5).

The introducer shaft (1) may vary in shape and form according to the
specifications of the anchoring device. Examples of suitable shapes include, but are not
limited to, cylinders, cones, squares rectangles and the like. More particularly, the size of

the opening in the introducer shaft is about the same as the size of the largest part of the anchoring device. More particularly, the size of the opening in the introducer shaft is slightly larger than the largest part of the anchoring device such that the anchoring device cannot move horizontally when placed inside of the introducer shaft. Typically,
5 the diameter of the opening of the introducer shaft will guide the head of the anchoring device along a predetermined axis.

The base plate (6) can be attached to the introducer shaft (1). The base plate (6) may vary in shape and form according to the specifications of the pre-operative planning. In particular embodiments, the base plate (6) is designed as a patient-specific anatomy
10 engagement surface, and thus the base plate (6) can be used for a specific patient in a specific operation. Such engagement surfaces are for instance described in EP 1 486 900 (which is hereby incorporated by reference).

As used herein, the term "patient-specific engagement surface" relates to a surface which is designed based on an individual patient's anatomy to include features
15 which have a custom fit on a specific location in a specific patient. The use of the patient-specific engagement surface in the devices as provided herein allows to ensure an improved or optimized accuracy of the positioning of the apparatus and thus of the introduction of the anchoring device for each patient. Accordingly, the term "patient-specific device or surface" is used to refer to a custom-made device or surface specific
20 to the individual patient's anatomy. In particular embodiments the devices as described herein may comprise at least one patient-specific element or surface which ensures a patient-specific fit on the anatomy of a patient. In particular embodiments, the patient-specific surface conforms to or is complementary with at least part of the patient's anatomy.

The pivot arms (2) are typically structures attached in at least one point to the
25 introducer shaft (1) such that the pivot arm can rotate about the attachment point. The pivot arm (2) may vary in shape and form according to the specifications of the anchoring device. At least a portion of the pivot arm is generally present inside the introducer shaft (2). In particular embodiments, the pivot arms engage only with the head
30 of the anchoring device, when it passes through the introducer shaft. The pivot arms are configured such that the head of the anchoring device pushes the pivot arms (2) from a first to a second position.

In particular embodiments, this can be ensured by allowing the pivot arms to rotate from a first to a second position. Typically, the pivot arms are configured such that

the change of the first position to the second position is ensured by the pressure of the head of the anchoring device on the pivot arm.

The pivot arms are releasably engaged to the slide arm. The slide arm (4) is typically a structure comprising at least one sliding element which provides an opening in the slide arm formed by the one or more sliding elements. In particular embodiments, the slide arm comprises two sliding elements which together form an opening which, in a first position of the sliding elements, is configured to guide the passage of the elongated body of the anchoring device and in a second position of the one or more sliding elements, allows the passage of the head of the anchoring device. The opening in the slide arm formed by the one or more sliding elements in a first position engages the body of the anchoring device inside of the introducer shaft in at least two points. This ensures that the elongated shaft of the anchoring device is moved through the slide arm according to a predefined axis. The one or more sliding elements are locked in said first position by the pivot arms. Thus, in this embodiment, the pivot arms form a locking mechanism for the slide arm. Only upon movement of the pivot arms (i.e. by the pressure of the head of the anchoring device), the one or more sliding elements move to a second position, forming an opening of the slide arm which allows the passage of the head of the anchoring device.

Indeed, as the transverse section of the head of the anchoring device is larger than that of the elongated body, the head of the anchoring device is prevented from passing through the slide arm unless the sliding elements move to create a larger opening. In particular embodiments, the sliding elements are rigidly positioned (e.g. by means of a resilient device) in a first position, which defines an opening allowing the passage of the elongated body of the anchoring device, but can be pushed apart by force, such as to widen the opening. In alternative embodiments, as described above, the sliding elements are configured to be locked into a first position by an engagement mechanism, but upon release of the engagement mechanism, are pulled apart (e.g. by means of a resilient device) so as to form a second position, which defines a larger opening allowing the passage of the head of the anchoring device. In particular embodiments the engagement mechanism is ensured by the pivot arms. In alternative embodiments, the engagement mechanism is ensured by the slide elements of another slide arm.

The interlock of a first moveable part with a second moveable part of the guiding system allows the position of one moveable part of the guiding system to influence the position of another moveable part of the guiding system. More particularly, movement of

one or more pivot arms (e.g. by the force provided by the contact with the head of the anchoring means) can ensure a release of the engagement with the sliding elements, such that they separate. Thus in particular embodiments a first (set of) moveable part(s) contain engagement features for interlocking with other one or more second moveable parts of the guiding system, whereby contact of the first moveable part(s) with the head of the anchoring device ensure release of the interlock. In particular embodiments, the one or more pivot arms are attached to or comprise a resilient device.

In further particular embodiments, the pivot arm (2) may be configured to engage the anchoring device (10) inside of the introducer shaft (1) in at least two points (i.e. both the elongated shaft and the head of the anchoring device). In these embodiments, the first position of the pivot arms defines the passage of the elongated shaft of the anchoring device and the second position defines the passage of the head of the anchoring device through the guide system.

In certain particular embodiments, the pivot arm (2) is not engaged by a resilient device.

Figures 1A - 1J illustrate an embodiment of the apparatus (10) as provided herein for introducing an anchoring device when engaged by the anchoring device (11). In Figure 1B, the anchoring device is inserted into the introducer shaft (1). Figure 1C: As the anchoring device (11) passes through the introducer shaft (1), the body of the anchoring device (7) engages the at least two points of the sliding arm (4), which ensures the correct orientation of the elongated shaft. The anchoring device (10) will not pass through the slide arm (4) unless it passes along the predefined axis. In Figures D and E, the head of the screw (8) engages the pivot arms (2) along the predetermined axis exerting a force on the pivot arms (2) such that the pivot arms (2) move outwards, releasing the releasably coupled slide arm (4). In Figure F, the resilient devices (5) exert a horizontal force on the sliding arm (4), pulling the sliding elements into a second position and expanding the opening in the slide arm e, such that the anchoring device, and more particularly the head of the anchoring device can pass through the slide arm according to a predefined axis. The anchoring device (11) is then able to be entirely introduced to the object, Figure G-I. Finally, the apparatus (10) can be removed from the object in one piece, Figure J.

In particular embodiments, the apparatus (10) as described herein can be returned to the starting position for re-use.

5 The predefined axis is the axis along which the anchoring device should be introduced into the object.

Where the object is a body part, the predefined axis can be based on an evaluation of the underlying tissue and/or according to pre-operative planning.

10 The apparatus particularly provides that the center of the introducer shaft and the center of any openings in the guide system are on the same axis. This determines the axis in which the anchoring device is passed through the device. It is thus possible for the user to ensure that the apparatus is placed onto the object such that the axis of the apparatus corresponds to the predefined axis.

15 Figures 2A and 2B illustrate a further embodiment of the apparatus for introducing an anchoring device as envisaged herein. With respect to Figure 2A, in one embodiment, the introducer shaft (21) is connected to a base plate (26). The apparatus further comprises a guide system which comprises a first slide arm (23) and a second slide arm (24). The first slide arm (23) and the second slide arm (24) are engaged by a resilient device such as an elastic device (25), but this is not a critical aspect.

20 Again, the introducer shaft (21) may vary in shape and form according to the specifications of the anchoring device. Examples of suitable shapes include, but are not limited to, cylinders, cones, squares rectangles and the like. Preferably, the size of the opening in the introducer shaft is about the same as the size of the largest part of the anchoring device. More preferably, the size of the opening in the introducer shaft is slightly larger than the largest part of the anchoring device such that the anchoring device cannot move horizontally when placed inside of the introducer shaft.

25 The base plate (26) can be attached to the introducer shaft (21). The base plate (26) may vary in shape and form according to the specifications of the pre-operative planning. In certain embodiments, the base plate (26) is designed as a patient-specific anatomy engagement surface, and thus the base plate (26) can be used for a specific patient in a specific operation. Such engagement surfaces are for instance described in
30 EP 1 486 900 (which is hereby incorporated by reference).

The guiding system of the apparatus according to this embodiment has the same function as described above. Indeed, the guide system which is located at least in part of the introducer shaft ensures that the elongated shaft is engaged in a specific position such that the anchoring device passes through the apparatus according to a predefined axis.

In this embodiment, the guiding system comprises two sliding arms. The opening in the first slide arm formed by the one or more sliding elements in a first position engages the body of the anchoring device inside of the introducer shaft in at least two points. This ensures that the elongated shaft of the anchoring device is moved through the slide arm according to a predefined axis.

The one or more sliding elements of the second sliding arm are locked in a first position by the sliding elements of the first sliding arm. Only upon movement of the sliding elements of the first sliding arm, is the engagement mechanism released and can the one or more sliding elements of the second sliding arm move to a second position, forming an opening of the second slide arm which allows the passage of the head of the anchoring device.

Thus, the head of the anchoring device, when introduced into the introducer shaft, first engages with the first slide arm. The force of inserting the head of the anchoring device into the opening of the first slide arm forces the sliding elements apart (whereby optionally resilient devices attached thereto are also pushed outwards), such that a larger opening is formed and the head of the anchoring device is allowed to move through the first slide arm along the predefined axis. As the first sliding arm moves outward, it releases the releasably engaged second slide arm. As the head of the anchoring device enters the second slide arm, there is again an outward force exerted on the sliding elements (and where applicable the resilient devices attached thereto), expanding the opening in the second slide arm and allowing the anchoring device to move through the second slide arm along the predefined axis.

Figures 3A-3C illustrate a further embodiment of the apparatus for introducing an anchoring device into an object. The apparatus comprises an introducer shaft and a guide system located at least in part therein. As illustrated in Figure 3A, in particular embodiments, the introducer shaft (31) may be connected to a base plate (34). The apparatus as illustrated in Figure 3 further has a guide system which comprises several pivot arms (32).

As in the previous embodiments, the introducer shaft (31) may vary in shape and form according to the specifications of the anchoring device. Examples of suitable shapes include, but are not limited to, cylinders, cones, squares rectangles and the like. Preferably, size of the opening in the introducer shaft is about the same as the size of
5 the largest part of the anchoring device. More preferably, the size of the opening in the introducer shaft is only slightly larger than the largest part (i.e. typically the head) of the anchoring device such that the anchoring device cannot move horizontally when placed inside of the introducer shaft.

The base plate (34) can be attached to the introducer shaft (31). In particular
10 embodiments the base plate (34) may have features which allow specific positioning on the object of interest.

Where the object of interest is a body part, the base plate (34) may vary in shape and form according to the specifications of pre-operative planning. In certain
15 embodiments, the base plate (34) is designed to comprise a patient-specific anatomy engagement surface, and thus the base plate (34) can be used for a specific patient in a specific operation. Such engagement surfaces are for instance described in 1 486 900 (which is hereby incorporated by reference).

In the embodiment of the apparatus as described herein illustrated in Figure 3,
20 the guiding system comprises 2, 3, 4 or more pivot arms which contact the anchoring device as it is introduced into the introducer shaft (31). In particular embodiments, during the passing of the anchoring device through the introducer shaft, the pivot arms contact the anchoring device in at least two contact points on the head and at least two contact points on the elongated body. In particular embodiments, at least the contact points on
25 the elongated body ensure that the body of the anchoring device moves through the apparatus according to a specific axis. In further embodiments, the four points of contact together force the anchoring device to move through the introducer shaft along the predefined axis. The pivot arms can be moved from this first position, wherein the opening formed by the distal ends of the pivot arms allow passage of the elongated body
30 of the anchoring device but does not allow the passage of the head of the anchoring device through the introducer shaft, to a second position wherein the pivot arms rotate slightly, and form at that same distal end a larger opening allowing the passage of the head of the anchoring device. In particular embodiments, the force of the head of the

anchoring device against the pivot arms ensures the rotation of the pivot arms, such that the opening is widened.

5 It will be understood by the skilled person that the apparatus envisaged herein may additionally or alternatively be used to guide a drilling tool, for instance but not necessarily to make a hole in the bone where the anchoring device is to be introduced. Typically in these embodiments, the introducer shaft is (also) used as a drill guide. Optionally, the features of the apparatus envisaged herein can similarly be used to guide the drill of a drilling tool, in a way similar to that described herein for the body of the
10 anchoring device. Alternatively, a different guide system can be provided for guiding the drill. In particular embodiments, the apparatus comprises one or more features which makes it possible to limit/determine drilling depth. In particular embodiments this is ensured by the length of the introducer shaft.

15 Also envisaged herein are methods for the manufacture of the apparatuses described herein.

In particular embodiments, the methods of manufacturing the apparatus as described herein comprise

- 20 a) determining the features of the anchoring device comprising a head and an elongated shaft
- b) designing a device comprising:
an introducer shaft and a guide system comprised at least in part inside of the introducer shaft, whereby the guide system comprising two or more parts movable with respect to the introducer shaft. The two or more moveable parts
25 of the guide system are designed such that, upon introduction of the anchoring device into the introducer shaft, they engage with the body of the anchoring device thereby ensuring that said anchoring device is directed through the apparatus according to a predefined axis; and
- c) producing said apparatus based on the design obtained in step b).

30 In particular embodiments said movable parts are designed to be able to move from a first position to a second position. More particularly, the guide system is designed such that the passing of the head of the anchoring device past a certain point in the introducer shaft, typically past a contact point on the guide system, ensures that one or

more of the moveable parts are moved from a first to a second position. In particular embodiments the guide system comprises a first (set of) moveable part(s) and a second (set of) moveable part(s), whereby the first and second (set of) moveable part(s) are releasably engaged, i.e. the first (set of) moveable part(s) is configured to prevent the
5 movement of a second (set of) moveable part(s) by a mechanism which can be released, more particularly when the anchoring device by passing through the introducer shaft, puts pressure on the first (set of) moveable part(s). Typically, the first (set of) moveable part(s) is designed to engage with the body of the anchoring device upon
10 introduction of the anchoring device into the apparatus and defines the passage of the body of the anchoring device in a first position. Movement of said first (set of) moveable parts to a second position unlocks said second (set of) moveable part(s), which itself is configured to be able to move from a first to a second position.

In particular embodiments, a first position of the first (set of) moveable part(s) is designed to define the passage of the longitudinal shaft according to a predetermined
15 axis and said second position of said second (set of) moveable part(s) defines the passage of the head of said anchoring device through the guide system according to said same predetermined axis;

In particular embodiments, the device is designed to comprise one or more (additional) features to allow the device to function as a drilling guide.

20 In particular embodiments, the device is manufactured by additive manufacturing.

In particular embodiments, the apparatus as envisaged herein is intended for the introduction of an anchoring device on a body part. In further particular embodiments, the apparatus comprises patient-specific elements, such as contact surfaces. The generation of patient-specific devices is done based on pre-operative images and/or
25 models of the anatomy surrounding the surgical area, and the planning of the surgery. More particularly, the generation of patient-specific apparatuses is done based on pre-operative images of the surgical area and planning of the surgery. Accordingly, methods for producing the surgical tools as envisaged herein typically comprise the steps of:

- a) obtaining volume information of the anatomy of the body part that requires
30 surgery;
- b) obtaining the direction of the anchoring device to be introduced into said body part;

c) identifying and selecting parts of the bone surrounding the surgical area which are suitable as landmarks or positioning areas for securing the position of the guide apparatus for said patient;

5 d) designing (and producing) a patient-specific base plate for an apparatus for the introduction of said anchoring device, wherein the apparatus comprises one or more patient-specific elements and/or surfaces corresponding to the surfaces identified in step (c) and positioning of said patient-specific base plate of said apparatus on said surface ensures the correct orientation of the axis of said apparatus in line with the direction determined in step (b).

10 In particular embodiments the method encompasses determining, based on the length of the anchoring device, the position of the head and the body of the anchoring device when entering the introducer shaft (first anchoring device position). The guide system is then designed to comprise one or more first moveable parts which contact the shaft of the anchoring device, while typically the elongated shaft is adapted to contact
15 the head of the anchoring device. The movable parts are designed to be able to move from a first position to a second position, when the anchoring device moves through the introducer shaft (second anchoring device position) such that the head of the anchoring device makes contact with a contact point. In particular embodiments as described above, the guide system comprises a first (set of) moveable part(s) and a second (set of)
20 moveable part(s), whereby the first and second (set of) moveable part(s) are releasably engaged, i.e. the first (set of) moveable part(s) is configured to prevent the movement of a second (set of) moveable part(s) by a mechanism which can be released, more particularly when the anchoring device by passing through the introducer shaft (from the first to the second anchoring device position), puts pressure on the first (set of)
25 moveable part(s). Typically, the first (set of) moveable part(s) is designed to engage with the body of the anchoring device upon introduction of the anchoring device into the apparatus and defines the passage of the body of the anchoring device in a first position. Movement of said first (set of) moveable parts to a second position unlocks said second (set of) moveable part(s), which itself is configured to be able to move from a first to a
30 second position.

The step of obtaining volume information typically comprises obtaining digital patient-specific image information which can be done by any suitable means known in the art, such as for example a computer tomography (CT) scanner, a magnetic

resonance imaging (MRI) scanner, an ultrasound scanner, or a combination of Roentgenograms. A summary of medical imaging has been described in "Fundamentals of Medical imaging", by P. Suetens, Cambridge University Press, 2002.

In particular embodiments, the device is designed to function (either additionally
5 or alternatively) as a drilling tool. Optionally the drilling tool can be used for providing a hole in said body part, such as a bone, on the location where the anchoring device is to be positioned. In particular embodiments this may entail the addition of one or more features to the design of the device to further allow the device to function as a drilling guide. In particular embodiments, this involves adjusting the length of the introducer
10 shaft to determine the drilling depth. Further provided herein is the manufacturing of the patient specific device as described herein.

In a particular embodiment, Additive Manufacturing (AM) techniques are used for manufacturing the patient-specific devices as described herein, or parts thereof. Indeed, in particular embodiments, the devices comprising the patient-specific elements. AM
15 techniques are particularly useful to manufacture patient-specific contact surfaces, or to produce the surgical guides in one piece. As an example, the manufacturing of medical-image-based patient-specific surgical instruments via AM is described in US Pat. No. 5.768.134 (Swaelens et al).

AM can be defined as a group of techniques used to fabricate a tangible model of
20 an object typically using three-dimensional (3-D) computer aided design (CAD) data of the object. Currently, a multitude of Additive Manufacturing techniques is available, including stereolithography, Selective Laser Sintering, Fused Deposition Modeling, foil-based techniques, etc.

Selective laser sintering uses a high power laser or another focused heat source
25 to sinter or weld small particles of plastic, metal, or ceramic powders into a mass representing the 3-dimensional object to be formed.

Fused deposition modeling and related techniques make use of a temporary transition from a solid material to a liquid state, usually due to heating. The material is driven through an extrusion nozzle in a controlled way and deposited in the required
30 place as described among others in U.S. Pat. No. 5.141.680.

Foil-based techniques fix coats to one another by means of gluing or photo polymerization or other techniques and cut the object from these coats or polymerize the object. Such a technique is described in U.S. Pat. No. 5.192.539.

Typically AM techniques start from a digital representation of the 3-D object to be formed. Generally, the digital representation is sliced into a series of cross-sectional layers which can be overlaid to form the object as a whole. The AM apparatus uses this data for building the object on a layer-by-layer basis. The cross-sectional data
5 representing the layer data of the 3-D object may be generated using a computer system and computer aided design and manufacturing (CAD/CAM) software.

The apparatuses as described herein may be manufactured in different materials. Particularly, the apparatus or part thereof is formed from a heat-tolerable material allowing it to tolerate high-temperature sterilization. In the case selective laser sintering
10 is used as an AM technique, the body part may be fabricated from a polyamide such as PA 2200 as supplied by EOS, Munich, Germany or any other material known by those skilled in the art may also be used.

Also envisaged herein are methods of introducing an anchoring device along a
15 predefined axis in an object comprising the steps of:

- a. Determining the proper axis for introduction of said anchoring device into said object
- b. Positioning an apparatus as described herein on said object such that the predefined axis of the device corresponds to said proper axis.
- c. Inserting an anchoring device into the introducer shaft of said apparatus
- 20 d. Passing said anchoring device through said guiding system of said apparatus; and
- e. Removing said apparatus from said object.

Thus, the use of the apparatus as described herein has the advantage that the anchoring device can be entirely introduced into the object, such that removal of the device from the object is in no way obstructed, whereby the correct orientation of the
25 anchoring device is maintained. This is ensured by the guide system which in a first position ensures guidance of the body of the anchoring device according to a predetermined axis and in a second position allows passage of the head of the anchoring device. Typically, the anchoring device must be inserted in the anchoring device by exerting some force, such that the head of the anchoring device moves the
30 guide system from the first position to the second position.

In particular embodiments, the apparatus is used for introducing an anchoring device into an object according to a desired path which is determined by planning. According to these embodiments, the introduction of an anchoring device comprises the steps of:

- a. Obtaining digital scan of said object
- b. Determining through planning the proper axis for introduction of said anchoring device in said object
- c. Positioning an apparatus as described herein on said object, said proper axis
5 corresponding to said predetermined axis of said apparatus.
- d. Inserting an anchoring device into the introducer shaft of said apparatus
- e. Passing said anchoring device completely through said guide system of said apparatus; and
- f. Removing said apparatus from said object.

10 In particular embodiments, the apparatus is also used for guiding a drilling tool in order to make a hole for the anchoring tool in the object. Thus, methods are also provided which involve, after the positioning of the apparatus as described herein on the object, the drilling of a hole through the object, whereby the apparatus is used as a drill guide. After the drill has been removed, the device can optionally be used for
15 positioning an anchoring device.

Claims

1. An apparatus for introducing an anchoring device into an object, said anchoring device having a head and an elongated body, wherein said head has a larger cross section than said elongated body, said apparatus comprising:
 - 5 a. an introducer shaft configured to engage the head of the anchoring device; and
 - b. a guide system positioned, at least in part, inside said introducer shaft,wherein said guide system is configured to engage with part of said anchoring device such that the anchoring device is prevented from passing through the
10 introducer shaft unless the anchoring device passes through the guide system according to a predefined axis.
2. A combination of an apparatus according to claim 1 and an anchoring device for use therewith, comprising an elongated body and a head, wherein the diameter of the head is greater than that of the elongated body.
- 15 3. The apparatus according to claim 1 or combination according to claim 2 wherein, the introducer shaft is configured to engage with the head of the anchoring device and the guide system is configured to engage with the elongated body of the anchoring device as the anchoring device enters the apparatus.
4. The apparatus according to claim 1 or 3 or the combination of claim 2 wherein the
20 guide system comprises two or more guiding parts movable with respect to the introducer shaft from at least a first position to at least a second position, which are configured to engage with the elongated body of the anchoring device inside the introducer shaft, and
wherein said first position defines the passage of the elongated body and said
25 second position defines the passage of the head of the anchoring device through the guide system according to a predetermined axis.
5. The apparatus or combination according to claim 4 wherein the guide system comprises a locking mechanism locking the movable guiding parts into the first position, and wherein the locking mechanism is configured to be released when
30 the head of the anchoring device passes a certain release point along the longitudinal axis of the introducer shaft.
6. The apparatus or combination according to claim 4 or 5 wherein the movable guiding parts comprise a first slide arm, the first slide arm comprising two or more sliding elements which allow for movement along a uniform axis and which provide

an opening in the first slide arm sized to engage with the elongated body of the anchoring device.

- 5 7. The apparatus or combination according to claim 5 or 6 wherein the locking mechanism comprises one or more pivot arms, wherein said pivot arms are releasably coupled to the movable guiding parts, wherein the pivot arms can rotate with respect to the introducer shaft from at least a first position to at least a second position, wherein in said first position the pivot arms lock the movable guiding parts into their said first position, wherein in said second position the pivot arms release the movable guiding parts, and wherein the pivot arms are configured to be
- 10 pushed from said first position to said second position by the head of the anchoring device as it passes the release point along the longitudinal axis of the introducer shaft.
8. The apparatus or combination according to claim 7 wherein the pivot arms are spaced equally along the circumference of the introducer shaft.
- 15 9. The apparatus or combination according to any of claims 5 to 8 wherein the locking mechanism comprises a second slide arm, the second slide arm comprising one or more sliding elements allowing the movement along a uniform axis, the slide elements being releasably coupled to the movable guiding parts, wherein the slide elements can move with respect to the introducer shaft from at
- 20 least a first position to at least a second position, wherein in said first position the slide elements are configured to lock the movable guiding parts into their said first position, wherein in said second position the slide elements are configured to release the movable guiding parts, and wherein the slide elements are configured to be pushed from said first position to said second position by the head of the
- 25 anchoring device as it passes the release point along the longitudinal axis of the introducer shaft.
- 30 10. The apparatus or combination according to any of claims 5 to 8 wherein the locking mechanism comprises two or more pivot arms, each pivot arm rigidly attached to one of the two or more movable guiding parts, wherein the pivot arms can rotate with respect to the introducer shaft from at least a first position to at least a second position, wherein in said first position the pivot arms are configured to lock the movable guiding parts into their said first position, wherein in said second position the pivot arms are configured to bring the movable guiding parts into their said second position, wherein the pivot arms are configured to engage

with the head of the anchoring device, and wherein the rotational axes of the pivot arms are configured to cross the longitudinal axis of the introducer shaft at the release point, such that the head of the anchoring device and the elongated body of the anchoring device push the pivot arms and the movable guiding parts in their
5 respective first positions as the anchoring device passes through the apparatus and while the head of the anchoring device has not yet passed the release point.

11. The apparatus or combination according to claim 10 wherein the pivot arms are spaced equally along the circumference of the introducer shaft.

12. The apparatus or combination according to any of claims 4 to 11 wherein the
10 guiding system further comprises at least one resilient device attached to the movable guiding parts.

13. The apparatus or combination according to claim 12 wherein the resilient device is a spring.

14. The apparatus or combination according to claim 12 or 13 wherein the resilient
15 device pushes or pulls the movable guiding parts into their first position and the head of the anchoring device pushes the movable guiding parts into their second position as it passes them.

15. The apparatus or combination according to any of claim 12 to 14 wherein the
20 resilient device pushes or pulls the movable guiding parts into their second position when they are released by the locking mechanism.

16. The apparatus or combination according to any of claims 5 to 15 wherein the guiding system comprises at least one resilient device attached to the locking mechanism.

17. The apparatus or combination according to claim 16 wherein the resilient device
25 is a spring.

18. The apparatus or combination according to claim 16 or 17 wherein the resilient device pushes or pulls the locking mechanism into the locked position.

19. The apparatus or combination according to any of claims 1 to 18 wherein the introducer shaft has at least the same length as the anchoring device.

30 20. The apparatus or combination according to any of claims 1 to 19, wherein said object is a body part of a patient and the predefined axis is determined through patient-specific pre-operative planning.

21. The apparatus or combination according to any of claims 1 to 20, wherein the apparatus further comprises a base plate.

22. The apparatus or combination according to any of claims 1 to 21, wherein the apparatus is an off-the-shelf device that can be assembled to a base plate.
23. The apparatus according to claim 21 or 22, wherein the base plate has a surface which specifically mates with said object.
- 5 24. An apparatus for introducing an anchoring device comprising a head and an elongated shaft in an object, the apparatus comprising:
an introducer shaft; and
a guide system comprised at least in part inside the introducer shaft, wherein said guide system is configured to engage with said anchoring device, such that the
10 anchoring device is prevented from passing through the introducer shaft unless the anchoring device passes through the guide according to a predefined axis.
25. The apparatus of claim 24, wherein said guide system comprises two or more parts movable with respect to the introducer shaft from at least a first position to at least a second position, which, during the passage of the anchoring device engage
15 with said anchoring device simultaneously in at least two different cross-sections of the longitudinal axis of the anchoring device; wherein said first position defines the passage of the longitudinal shaft and said second position defines the passage of the head of said anchoring device through the guide system according to a predetermined axis.
- 20 26. The apparatus according to Claim 24 or 25, wherein introducer shaft has the same as the length as the anchoring device.
27. The apparatus according to any of claims 24 to 26, wherein the guide system comprises:
- at least two pivot arms (2), wherein said pivot arms engage the anchoring device
25 inside of the introducer shaft in at least two points; and
- a slide arm releasably coupled to the at least two pivot arms, the slide arm comprising one or more sliding elements which allow for movement along a uniform axis and which provide an opening in the slide arm; , wherein the opening in the slide arm in a first position of the one or more sliding elements engages the
30 anchoring device inside of the introducer shaft in at least two points such that the body of the anchoring device passes through the pivot arms according to a predefined axis; and wherein movement of the head of the anchoring device through the pivot arms ensures the movement of the one or more sliding elements to a second position, allowing passage of the head of the anchoring device.

28. The apparatus according to Claim 27, wherein the pivot arms are equally spaced throughout the introducer shaft.
29. The apparatus according to Claim 26 or 27, further comprising at least one resilient device attached to the sliding element which enables the sliding elements to move
5 along the uniform axis.
30. The apparatus according to any of claims 26 to 28, wherein the pivot arms are attached to a resilient device.
31. The apparatus according to Claim 29 or 30, wherein one or both of the resilient devices is spring.
- 10 32. The apparatus according to any of claims 24 to 31, wherein the guide system comprises a first and second slide arm, wherein the second slide arm is releasably coupled to the first slide arm,, each comprising one or more sliding elements which allow for movement along a uniform axis and which provide an opening in the slide arm; , wherein the opening in the first slide arm engages the anchoring device
15 inside of the introducer shaft in at least two points such that the body of the anchoring device passes through the first slide arm according to a predefined axis and wherein movement of the head of the anchoring device through the first slide arm allows the movement of the one or more sliding elements of the second slide arm, allowing passage of the head of the anchoring device.
- 20 33. The apparatus according to claim 32, further comprising a resilient device attached to the one or more of each of the sliding elements which enables the sliding elements of the first and/or second slide arm to move along a uniform axis.
34. The apparatus according to claim 24, wherein the guiding system comprises:
25 two or more pivot arms, wherein said pivot arms can engage with said anchoring device simultaneously in at least two different cross-sections of the longitudinal axis of the anchoring device such that the head of the anchoring device is prevented from passing through the pivot arms unless the anchoring device passes through the pivot arms according to a predefined axis.
35. The apparatus according to any of claims 24 to 34, wherein the predefined axis is
30 determined through patient-specific pre-operative planning.
36. The apparatus according to any of claims 24 to 35, wherein the apparatus further comprises a base plate.
37. The apparatus according to claim 36, wherein the base plate has a patient specific surface.

38. The apparatus according to any of claims 1 to 37, wherein said guide system is adapted to guide a drill.
39. A method of introducing an anchoring device along a predefined axis in an object comprising:
- 5 a. Determining the proper axis for introduction of said anchoring device into said object
- b. Positioning the apparatus according to any of claims 24 to 38 on said object such that the predefined axis of the device corresponds to said proper axis.
- c. Inserting an anchoring device into the introducer shaft of said apparatus
- 10 d. Passing said anchoring device through said guiding system of said apparatus; and
- e. Removing said apparatus from said object.
40. The method according to claim 39, which comprises:
- a. Obtaining digital scan of said object
- 15 b. Determining through planning the proper axis for introduction of said anchoring device
- c. Positioning the apparatus according to any of claims 24 to 38 on said object, said proper axis corresponding to said predetermined axis of said device.
- d. Inserting an anchoring device into the introducer shaft of said apparatus
- 20 e. Passing said anchoring device through said guiding system of said apparatus
- f. Removing said apparatus from said object.

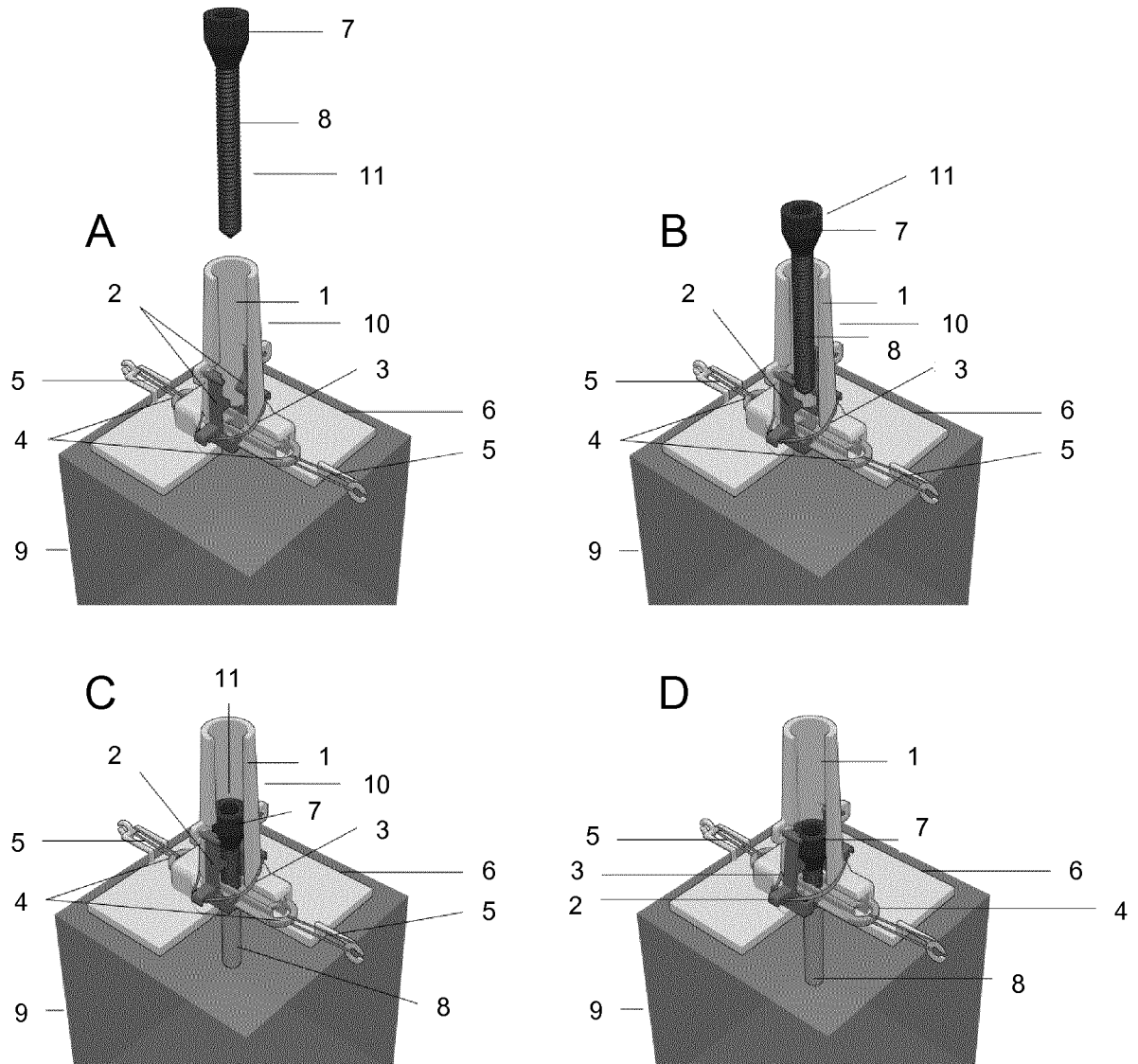

Figure 1

2/7

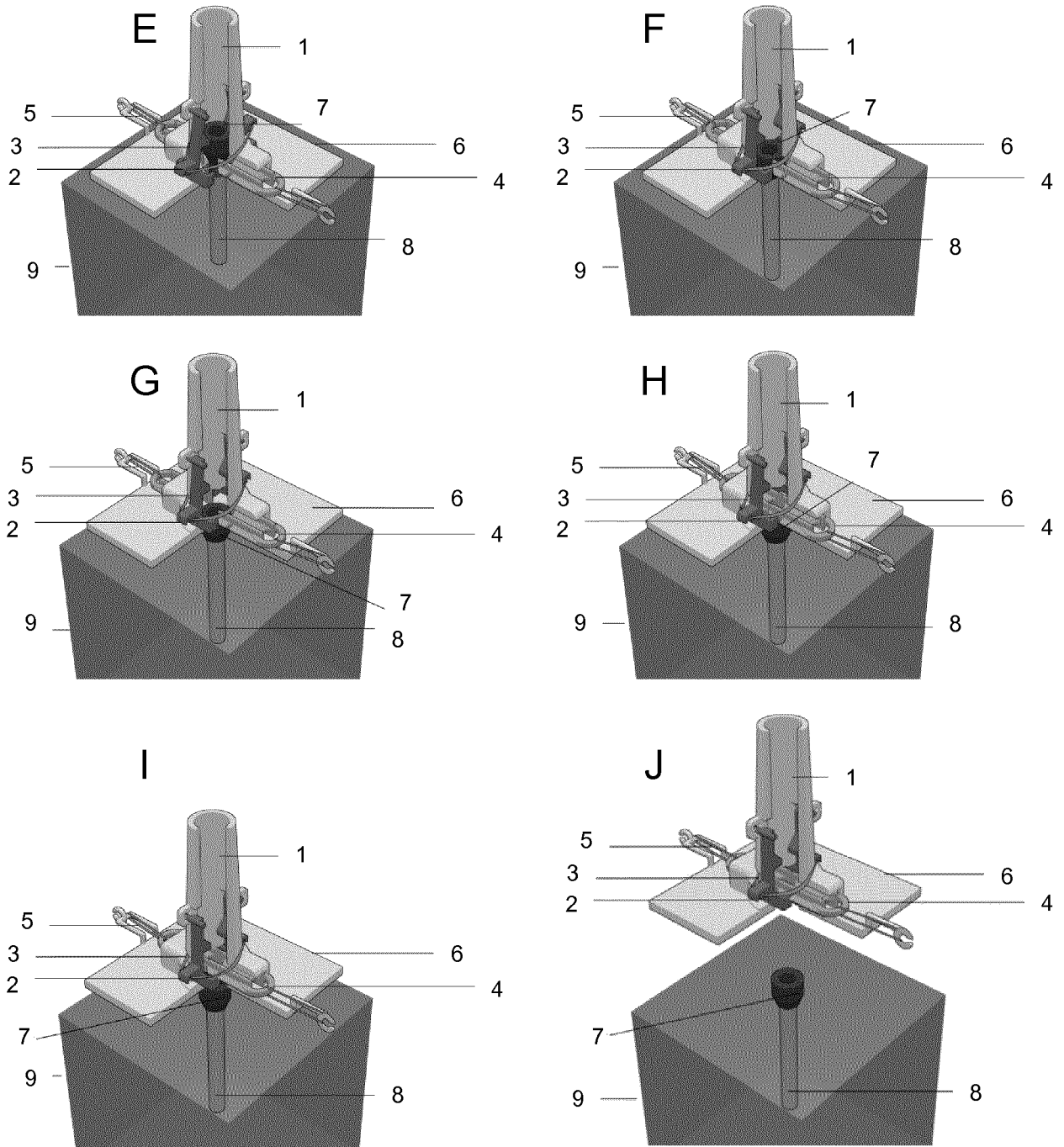

Figure 1

3/7

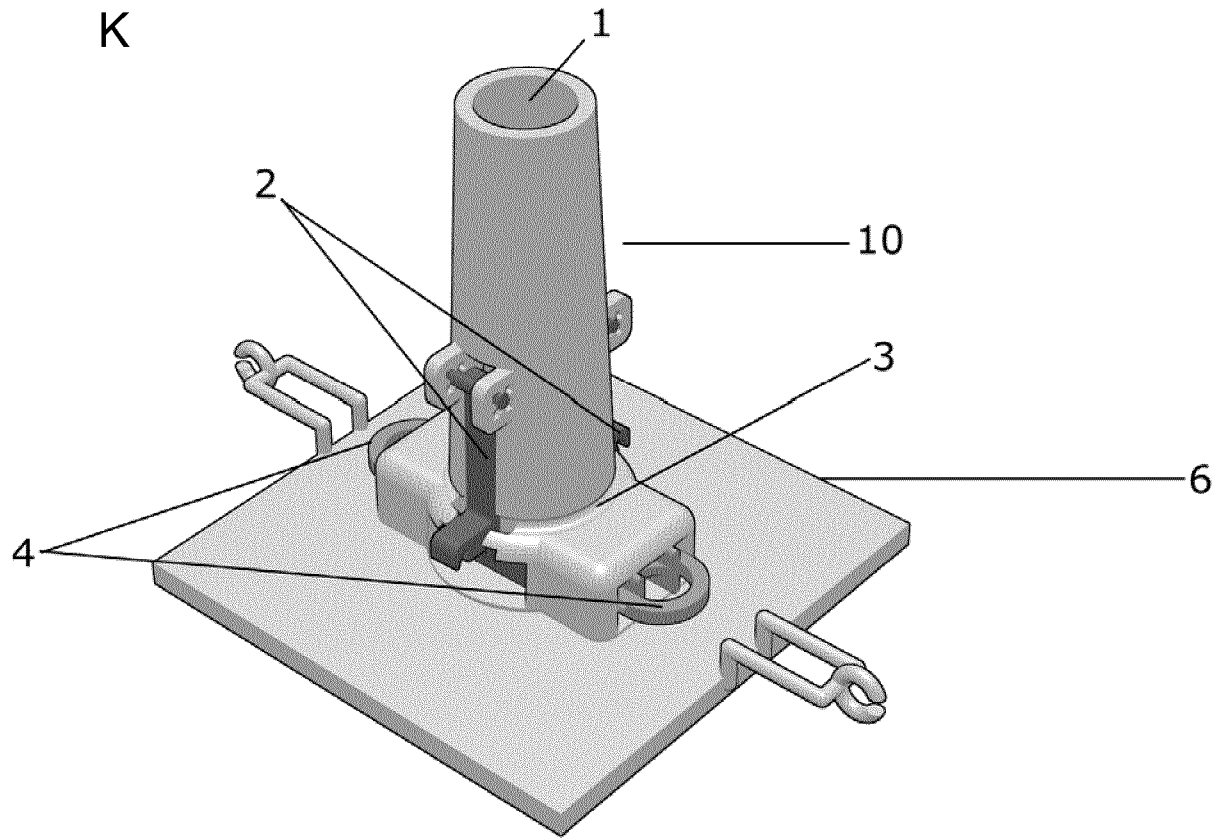

Figure 1

4/7

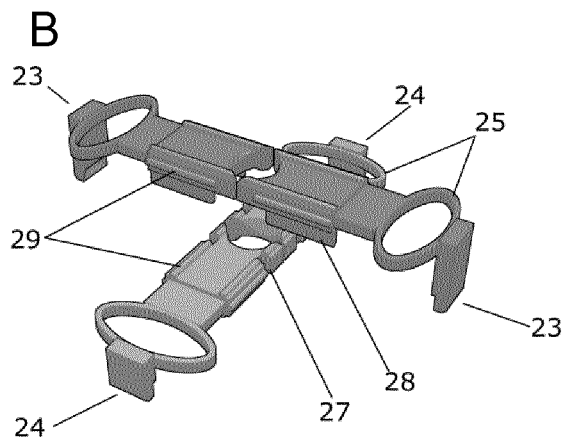
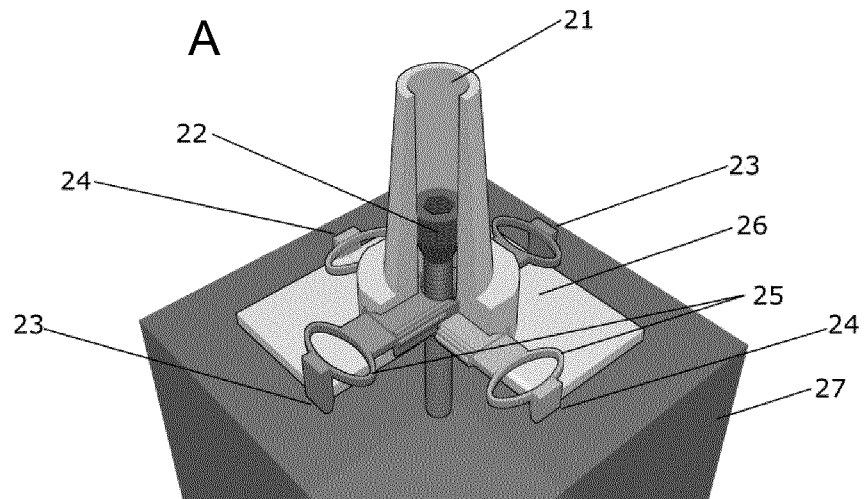

Figure 2

5/7

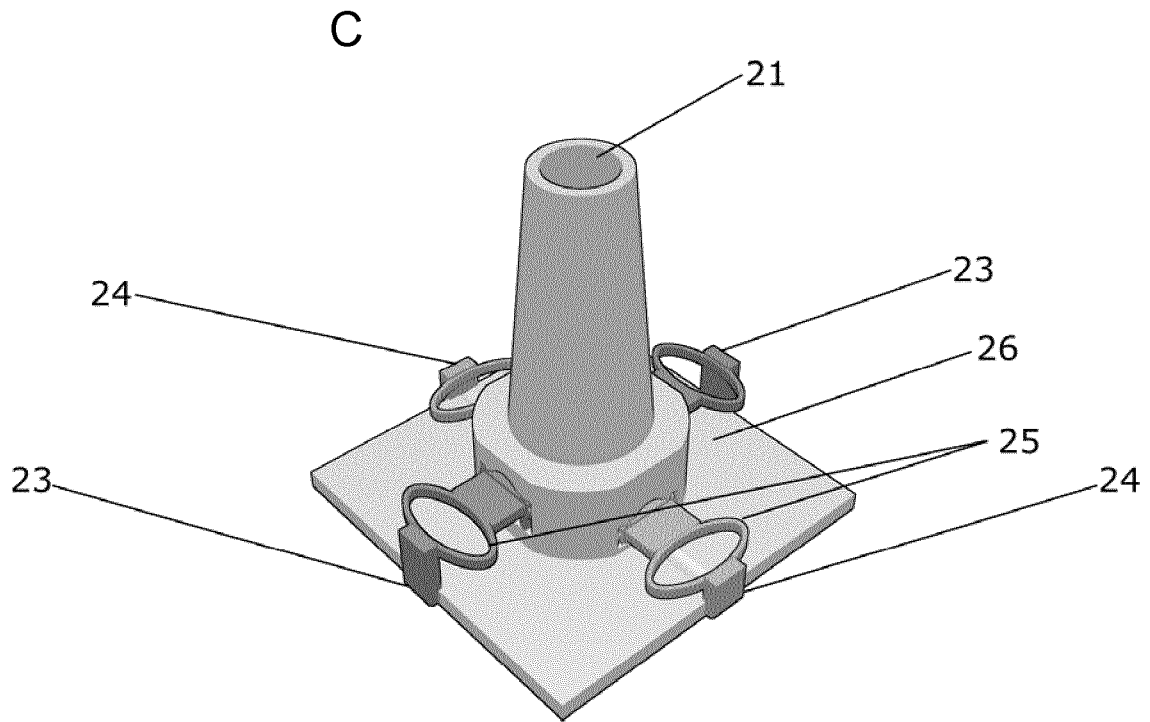

Figure 2

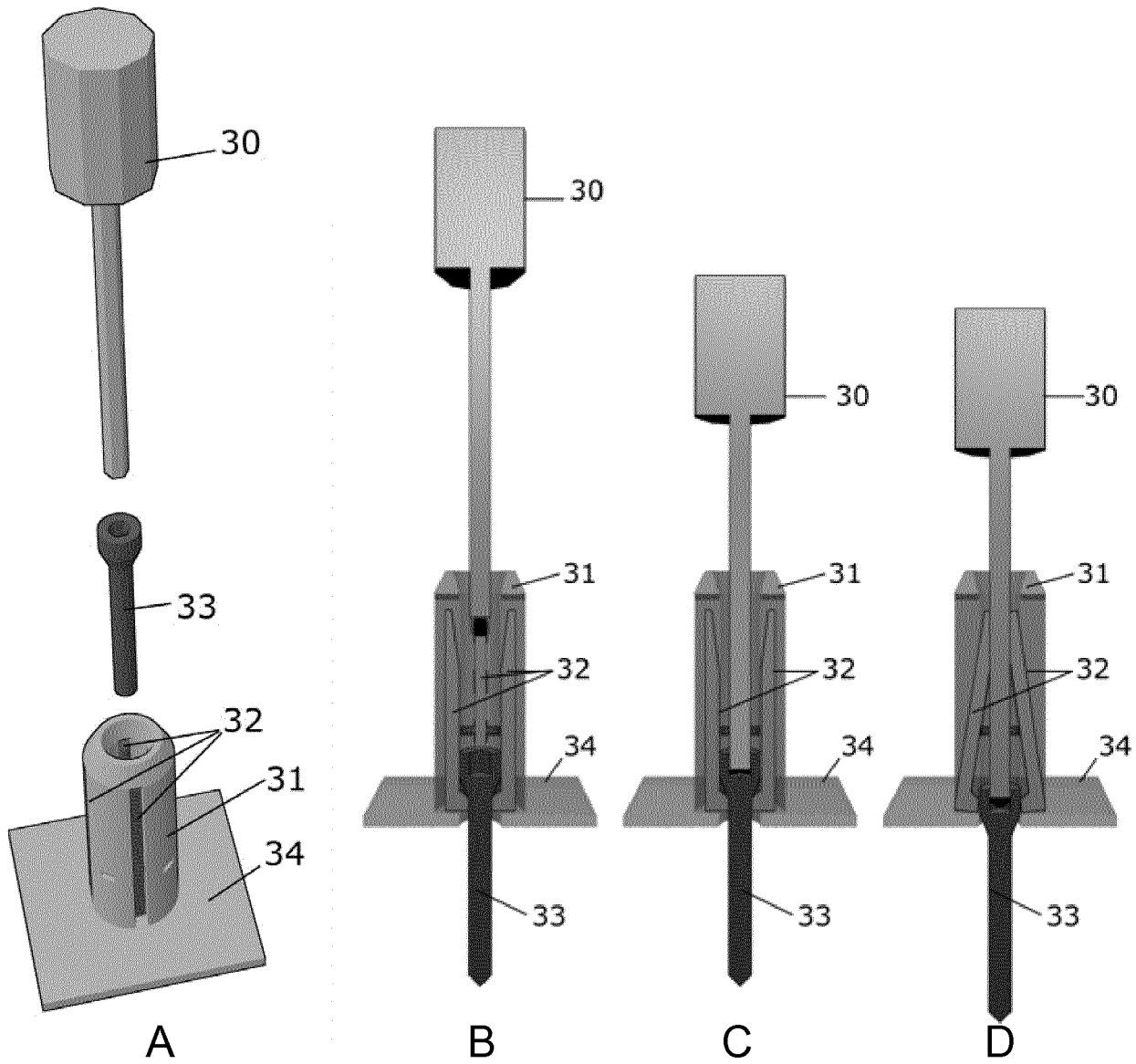

Figure 3

7/7

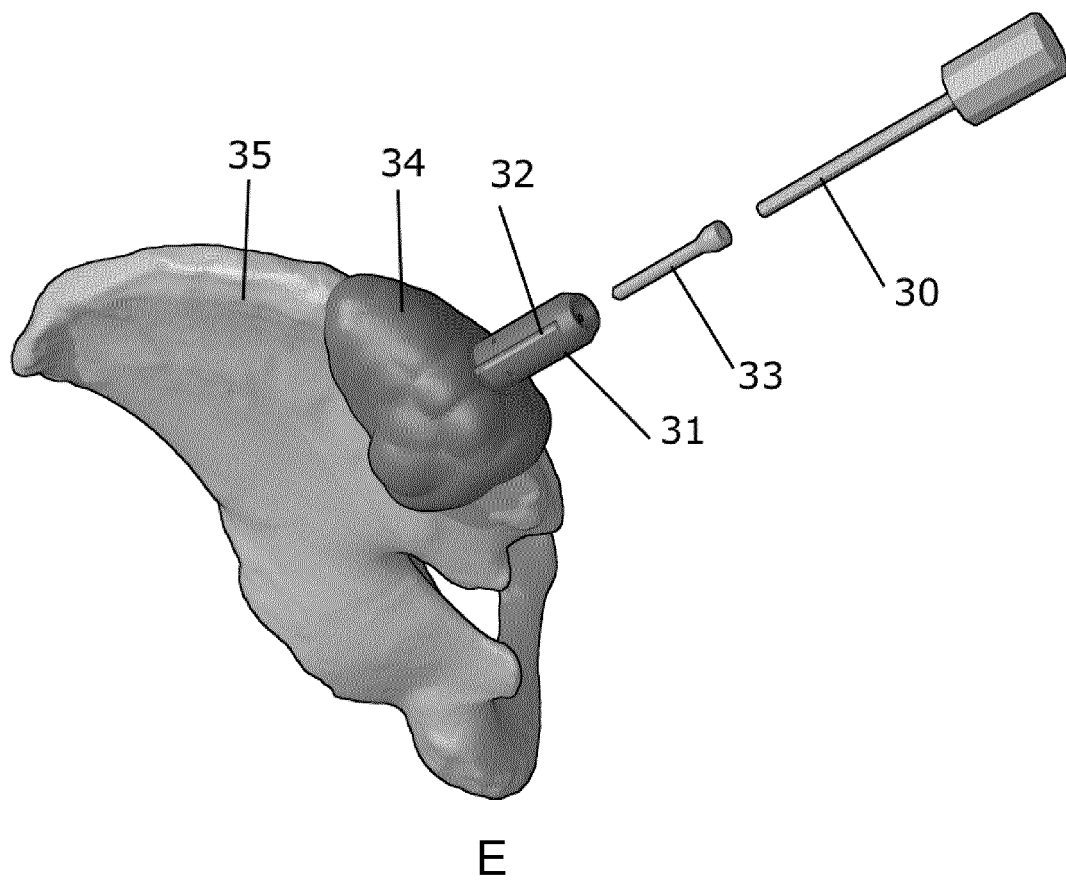

Figure 3

INTERNATIONAL SEARCH REPORT

International application No PCT/EP2012/076600
--

A. CLASSIFICATION OF SUBJECT MATTER
 INV. A61B17/17
 ADD. A61B17/34

According to International Patent Classification (IPC) or to both national classification and IPC

B. FIELDS SEARCHED

Minimum documentation searched (classification system followed by classification symbols)
 A61B

Documentation searched other than minimum documentation to the extent that such documents are included in the fields searched

Electronic data base consulted during the international search (name of data base and, where practicable, search terms used)
 EPO-Internal

C. DOCUMENTS CONSIDERED TO BE RELEVANT		
Category*	Citation of document, with indication, where appropriate, of the relevant passages	Relevant to claim No.
X	DE 20 2009 002639 U1 (MEDARTIS AG [CH]) 7 May 2009 (2009-05-07) figures 1a-5b -----	1-3, 19-24, 26, 35, 36, 38
X	US 5 295 994 A (BONUTTI PETER M [US]) 22 March 1994 (1994-03-22) figures 8A-9B -----	1, 3, 19-24, 26, 35-38
X	US 6 447 489 B1 (PETERSON FRANCIS C [US]) 10 September 2002 (2002-09-10) figure 11 -----	1, 3, 19-24, 26, 35-38
X	US 5 743 916 A (GREENBERG ALEX M [US] ET AL) 28 April 1998 (1998-04-28) figures 4A, 21D-F -----	24, 26, 35-38

Further documents are listed in the continuation of Box C. See patent family annex.

* Special categories of cited documents :

<p>"A" document defining the general state of the art which is not considered to be of particular relevance</p> <p>"E" earlier application or patent but published on or after the international filing date</p> <p>"L" document which may throw doubts on priority claim(s) or which is cited to establish the publication date of another citation or other special reason (as specified)</p> <p>"O" document referring to an oral disclosure, use, exhibition or other means</p> <p>"P" document published prior to the international filing date but later than the priority date claimed</p>	<p>"T" later document published after the international filing date or priority date and not in conflict with the application but cited to understand the principle or theory underlying the invention</p> <p>"X" document of particular relevance; the claimed invention cannot be considered novel or cannot be considered to involve an inventive step when the document is taken alone</p> <p>"Y" document of particular relevance; the claimed invention cannot be considered to involve an inventive step when the document is combined with one or more other such documents, such combination being obvious to a person skilled in the art</p> <p>"&" document member of the same patent family</p>
---	---

Date of the actual completion of the international search 12 April 2013	Date of mailing of the international search report 22/04/2013
--	--

Name and mailing address of the ISA/ European Patent Office, P.B. 5818 Patentlaan 2 NL - 2280 HV Rijswijk Tel. (+31-70) 340-2040, Fax: (+31-70) 340-3016	Authorized officer Hamann, Joachim
--	---

INTERNATIONAL SEARCH REPORT

International application No.
PCT/EP2012/076600

Box No. II Observations where certain claims were found unsearchable (Continuation of item 2 of first sheet)

This international search report has not been established in respect of certain claims under Article 17(2)(a) for the following reasons:

1. Claims Nos.: **39, 40**
because they relate to subject matter not required to be searched by this Authority, namely:
Rule 39.1(iv) PCT - Method for treatment of the human or animal body by surgery
2. Claims Nos.:
because they relate to parts of the international application that do not comply with the prescribed requirements to such an extent that no meaningful international search can be carried out, specifically:
3. Claims Nos.:
because they are dependent claims and are not drafted in accordance with the second and third sentences of Rule 6.4(a).

Box No. III Observations where unity of invention is lacking (Continuation of item 3 of first sheet)

This International Searching Authority found multiple inventions in this international application, as follows:

1. As all required additional search fees were timely paid by the applicant, this international search report covers all searchable claims.
2. As all searchable claims could be searched without effort justifying an additional fees, this Authority did not invite payment of additional fees.
3. As only some of the required additional search fees were timely paid by the applicant, this international search report covers only those claims for which fees were paid, specifically claims Nos. :
4. No required additional search fees were timely paid by the applicant. Consequently, this international search report is restricted to the invention first mentioned in the claims; it is covered by claims Nos. :

Remark on Protest

- The additional search fees were accompanied by the applicant's protest and, where applicable, the payment of a protest fee.
- The additional search fees were accompanied by the applicant's protest but the applicable protest fee was not paid within the time limit specified in the invitation.
- No protest accompanied the payment of additional search fees.

INTERNATIONAL SEARCH REPORT

Information on patent family members

International application No PCT/EP2012/076600
--

Patent document cited in search report	Publication date	Patent family member(s)	Publication date
DE 202009002639 U1	07-05-2009	DE 202009002639 U1	07-05-2009
		EP 2400913 A2	04-01-2012
		US 2011288596 A1	24-11-2011
		WO 2010097447 A2	02-09-2010

US 5295994 A	22-03-1994	NONE	

US 6447489 B1	10-09-2002	AU 774922 B2	15-07-2004
		AU 2956201 A	31-07-2001
		CA 2397118 A1	26-07-2001
		CN 1398173 A	19-02-2003
		DE 60115198 D1	29-12-2005
		DE 60115198 T2	29-06-2006
		EP 1248572 A1	16-10-2002
		ES 2254440 T3	16-06-2006
		JP 4485110 B2	16-06-2010
		JP 2003520098 A	02-07-2003
		MX PA02006985 A	06-09-2004
		US 6447489 B1	10-09-2002
		WO 0152754 A1	26-07-2001

US 5743916 A	28-04-1998	US 5743916 A	28-04-1998
		US 5888034 A	30-03-1999
