

(19) World Intellectual Property Organization
International Bureau



(43) International Publication Date
17 April 2008 (17.04.2008)

PCT

(10) International Publication Number
WO 2008/044066 A2

(51) International Patent Classification: **Not classified**

(21) International Application Number:
PCT/GB2007/050604

(22) International Filing Date: 2 October 2007 (02.10.2007)

(25) Filing Language: English

(26) Publication Language: English

(30) Priority Data:
0620039.8 10 October 2006 (10.10.2006) GB

(71) Applicant (for all designated States except US): **ITI SCOTLAND LIMITED** [GB/GB]; 191 West George St, Glasgow Strathclyde G2 2LB (GB).

(72) Inventors; and

(75) Inventors/Applicants (for US only): **EDWARDS, James, Ian** [GB/GB]; Cruachan, 22 Ramsay Road, Banchory, Aberdeen Kincardineshire AB31 5TT (GB). **DIVER, Peter, Thomas** [GB/GB]; 7 Downing Road, Portglenone, Ballymena Co. Antrim BT44 8PA (GB).

(74) Agent: **BINGHAM, Ian**; IP Asset LLP, 4th Floor, 33 Cavendish Square, London Greater London W1G 0PW (GB).

(81) Designated States (unless otherwise indicated, for every kind of national protection available): AE, AG, AL, AM,

AT, AU, AZ, BA, BB, BG, BH, BR, BW, BY, BZ, CA, CH, CN, CO, CR, CU, CZ, DE, DK, DM, DO, DZ, EC, EE, EG, ES, FI, GB, GD, GE, GH, GM, GT, HN, HR, HU, ID, IL, IN, IS, JP, KE, KG, KM, KN, KP, KR, KZ, LA, LC, LK, LR, LS, LT, LU, LY, MA, MD, ME, MG, MK, MN, MW, MX, MY, MZ, NA, NG, NI, NO, NZ, OM, PG, PH, PL, PT, RO, RS, RU, SC, SD, SE, SG, SK, SL, SM, SV, SY, TJ, TM, TN, TR, TT, TZ, UA, UG, US, UZ, VC, VN, ZA, ZM, ZW.

(84) Designated States (unless otherwise indicated, for every kind of regional protection available): ARIPO (BW, GH, GM, KE, LS, MW, MZ, NA, SD, SL, SZ, TZ, UG, ZM, ZW), Eurasian (AM, AZ, BY, KG, KZ, MD, RU, TJ, TM), European (AT, BE, BG, CH, CY, CZ, DE, DK, EE, ES, FI, FR, GB, GR, HU, IE, IS, IT, LT, LU, LV, MC, MT, NL, PL, PT, RO, SE, SI, SK, TR), OAPI (BF, BJ, CF, CG, CI, CM, GA, GN, GQ, GW, ML, MR, NE, SN, TD, TG).

Declarations under Rule 4.17:

- as to the identity of the inventor (Rule 4.17(i))
- as to applicant's entitlement to apply for and be granted a patent (Rule 4.17(ii))
- as to the applicant's entitlement to claim the priority of the earlier application (Rule 4.17(iii))
- of inventorship (Rule 4.17(iv))

Published:

- without international search report and to be republished upon receipt of that report

(54) Title: WIND AND WAVE POWER GENERATION

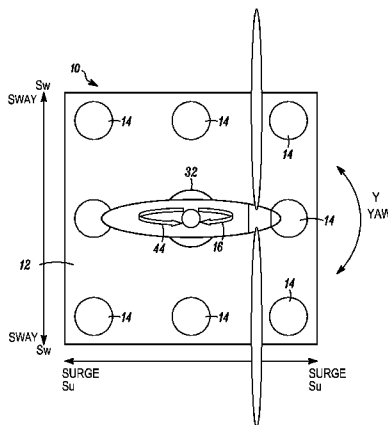

(57) Abstract: The present invention provides a wind and wave power generation system including a platform (12) and a wind turbine (16) rotatably mounted on a tower (32) and provided with an actuator (34) for changing the yaw angle of the turbine blade (38) relative to said tower (32). The system further includes a sensor (118) for detecting at least yaw motion of the platform and a controller (56) for causing actuation of the actuator (34) to cause movement of the rotor so as to at least partially correct detected yaw motion.

WO 2008/044066 A2

WIND AND WAVE POWER GENERATION

The present invention relates to floating power generation systems and relates particularly but not exclusively to such systems having stabilization control.

Offshore power generation which harnesses the power of the wind has the potential to become a major source of energy and has been the subject of much experimentation and development over the past forty or more years. It is well known to extract energy from the wind by causing the wind to drive a wind turbine which is, typically, mounted as high on the platform as possible so as to ensure it is exposed to the full force of the wind whilst being clear of any ground effect or interference created by the platform itself. Whilst such turbines are relatively efficient and are able to extract large amounts of energy from the wind, the higher efficiency turbines tend to have very large diameter blades and hence require very high platforms or towers upon which they can be safely mounted. On land this does not present a problem as the tower can be firmly secured to ground but the security of fixture is somewhat more problematic when mounted to a floating platform which is subjected to the motion of the waves. Any such motion causes the turbine to oscillate from a steady state condition and creates what can be adverse structural loadings on both the turbine and the support tower itself. Some water based wind turbine arrangements are operated to take advantage of the forward and backward motion caused by the waves interacting with the platform or floating column upon which it is mounted. In essence, forward motion creates an "apparent wind" to which the rotor blades are exposed and more energy can be extracted from the wind during any forward motion of the blades than can be extracted when the blades are either stationary or being rocked backwards. Whilst this additional energy extraction can be advantageous it has to be balanced against the structural loading on the support tower upon which the turbine is mounted and this can be undesirably high in stormy sea conditions and may lead to structural failure.

In addition to the above-mentioned problems, such platforms also suffer from adverse movement in up to six axes (roll, yaw, pitch, heave, sway and surge) whilst floating on what can be very choppy seas. Movement in any one or more axis will have an adverse affect on platform stability, structural loading and also power generation and is preferably reduced to a minimum in order to prolong platform life and energy extraction. Various systems have been proposed to stabilize the platform itself, one of which is discussed in EP 0053458 in which the column of water in an OWC is arrested and released subsequently in an attempt at synchronizing. Whilst the above arrangements provide very reasonable solutions the power generation or stability problems, maximizing power generation can sometimes be to the detriment of structural loading or stability whilst maximizing stability can have an adverse effect on power generation.

Yaw control is particularly important when attempting to stabilize a moored platform at sea and is not readily addressed by the above-mentioned arrangements. Often the waves are of such power, magnitude and direction as to sway the platform around on its moorings which are then placed under additional strain which can be substantial. When mooring lines are also provided they can exert a corrective force on the platform thus sending the platform into an oscillating motion which can be difficult to control and can sometimes be of a frequency that matches another external force which when combined with the yaw force places the platform under excessive load. Some platforms are designed to face into the oncoming waves and are shaped such as to provide a bow or other such feature but when such features are not present such platforms can become unstable in high sea states and this can also lead to severe strain being placed on the platform itself and any wind turbine structures placed thereon. This problem is exacerbated by wind/tide conditions which place the wind at an angle relative to the oncoming wave.

It is also known to harness the power of the waves either directly or indirectly and convert that energy into electricity which is then transported to shore for

subsequent use. The oscillating water column (OWC) has become a very popular method of converting wave energy into electrical power, whether as a shore-based, bottom-mounted or floating device. Whilst there are many ways of harnessing the wave energy, virtually every OWC proposed or built in the last 20 years has one or more Wells turbines which are driven by the pressurised air escaping from or entering the column as the water rushes in and out thereof. The popularity of the OWC has a great deal to do with the convenience with which the Wells turbine converts bi-directional airflows between wave chamber and atmosphere into unidirectional bursts of torque in the coupling of the electrical generator. Moreover, during lulls in the sea or when the air velocity drops to zero during twice-per-wave flow reversal, the Wells turbine needs little power to stay rotating. Simpler Wells turbines employ a set of fixed pitch blades and whilst these provide a generally very positive contribution to the creation of electrical energy the range of wave, and therefore airflow, conditions over which a fixed blade Wells turbine operates with reasonable efficiency is severely limited by blade stall.

Typically, Wells turbines use symmetrical profile blades with their chords in the plane of rotation and often produce positive torque only for angles of incidence between 2 and 13 degrees. Below 2 degrees, in the low air velocity operating area, the lift component is too small to produce positive torque and the rotor tends to lose speed. At angles of incidence above 13 degrees the blade section stalls. The rapidly increasing drag forces dominate the less rapidly declining lift forces and efficiency is compromised. If, however, the blades are such as to be able to change pitch so as to prevent the angle of incidence exceeding some maximum angle, for example 8 degrees, then it would produce positive torque at all angles of incidence above 2 degrees and efficiency would improve.

In operation, the water level oscillates up and down within the water column as the crests and troughs of the waves pass through the water column. If this oscillating water level is made to take place in a structural column opened at both ends, the air column above the water oscillates in a similar manner and, thus,

wave energy is thereby converted into low pressure, high volume air flow. Energy is then extracted from the moving air by a self-rectifying Wells turbine, in which rotation is unidirectional regardless in which axial direction air is flowing. In essence, the Wells turbine is essentially operated as a wind or aero turbine. The working interface is therefore between water and air, and air and rotor blades. The turbine reacts to the low pressure air stream which is far less destructive than directly absorbing the powerful impact force of sea waves. The efficiency of energy transfer between the wave and the air is high if not total whilst the energy transfer efficiency at the air/rotor blade is very much dependent upon good design and efficient management of the energy transfer itself.

In some arrangements it is known to use a flywheel to keep the turbine spinning by virtue of momentum during times when the waves are weak. It is also known to use two rotors in tandem configuration that rotate in opposite directions and are coupled to a common output. It is also known to use the variable-pitch turbine for performance-enhancing reactive loading by using the generator and turbine to pump bursts of energy into the wave chamber itself.

The present invention attempts to reduce the disadvantages associated with the above-discussed arrangements by providing a floatable platform which is stabilized relative to the sea by manipulation and control of the power extracting apparatus and which also attempts to increase the efficiency of power generation whilst stabilizing the platform.

Accordingly, the present invention provides a floatable platform comprising: a platform base; a motion sensor for determining the axial motion of said platform about or along one or more axes; a stability controller; a tower; a wind turbine mounted upon said tower, said turbine having a propeller and a rotational mount upon which said turbine is mounted for rotational movement about a longitudinal

axis of said tower; said motion sensor including a yaw detector for detecting the angular yaw position of the platform and being operably connected to said stability controller for supplying yaw data to said controller; and a yaw actuator for varying the yaw angle of the turbine relative to said tower, said yaw activator
5 being operably connected to said stability controller for receiving actuation signals therefrom, thereby to vary the angular position of said wind turbine relative to said tower.

Advantageously the platform includes a wind monitor for monitoring the direction
10 and velocity of any wind approaching said platform, said wind monitor being operably connected to said stabilization controller for supplying wind data thereto. In one arrangement the platform includes a pitch controller for controlling the pitch of said rotor blades, said pitch controller being operably connected to said stabilization controller for receiving control signals therefrom. The platform may
15 also include an RPM sensor for monitoring the speed of rotation thereof, said RPM sensor being operably connected to said stability controller for delivering rotational speed data thereto. Additionally or alternatively, there may be provided a Voltage and Current sensor for monitoring Voltage and Current output of said generator, said sensor being operably connected to said stability controller for
20 delivering Voltage and Current data thereto. When the platform is provided with a wind driven generator it may further include an excitation voltage controller for controlling the excitation voltage of said generator which is operably coupled to said stability controller for control thereby.

25 In an alternative arrangement there is provided a platform as described above and further including: an oscillating water column; an air flow control mechanism, for controlling the flow of air through the oscillating water column; wherein said axis sensor is operably connected to said stabilisation controller for transmitting axial motion data to said control and said control is operably connected to said
30 airflow control mechanism for controlling the flow of air through said oscillating

water column, thereby to at least partially stabilise said platform in one or more axes.

5 In one arrangement said airflow control mechanism comprises a flow (pressure) valve for controlling the flow of air through the column whilst in another arrangement said airflow control mechanism comprises an air driven turbine and a control mechanism for controlling the back pressure created thereby within the column.

10

Conveniently, said platform may have two oscillating water columns, said oscillating water columns being positioned at opposite ends of said platform to each other and each being operably connected to said stabilisation controller for control thereby. Alternatively, the platform may include a plurality of oscillating
15 water columns along each of said ends. Alternatively or additionally, the platform may have two oscillating water columns positioned at opposite sides of said platform to each other and each being operably connected to said stabilisation controller for control thereby. In some arrangements the platform may include a plurality of oscillating water columns along each of said sides.

20

Preferably, said displacement sensor comprises a multi-axis displacement sensor and may monitor axial displacement or movement in one or more of roll, pitch, yaw, heave, sway and surge of the platform.

25 Advantageously, the stabilisation controller includes a computer having a software program operable to control the stability of the platform in accordance with a pre-determined control strategy. Said stabilisation controller may also include a feedback control.

30 In one arrangement said water column or columns further include a surge prevention mechanism which may comprise a floating ball and means defining a

restricted orifice having a diameter smaller than said ball. Alternatively, said surge prevention mechanism may comprise a floating plate having an external diameter and means defining a restricted orifice having a diameter smaller than that of said plate. In a still further arrangement said surge prevention mechanism
5 may comprise a sliding plate valve having an actuator and means defining an orifice over which said plate valve is slid by said actuator.

Advantageously, the platform further includes a pressure sensor within one or more oscillating water columns, said pressure sensor being operably connected
10 to said stability controller for delivering pressure data thereto. The arrangement may include a sensor on each side of a wind turbine blade positioned therein, thereby to determine the pressure differential across the turbine.

Advantageously, the platform further includes a water level sensor within one or
15 more oscillating water columns, said level sensor being operably connected to said stability controller for delivering pressure data thereto. The platform may further include a wave sensor for determining the height, direction and frequency of waves, said wave sensor being operably connected to said stability controller for delivering wave data thereto.

20 In a still further arrangement the platform may include an anchor mechanism for anchoring said platform to an immovable object and said anchor mechanism may comprise three or more anchor lines secured at a first end to an immovable object and at an otherwise free end to a power generation apparatus. The
25 arrangement may further include one or more cable tension monitors for monitoring the tension in one or more of said cables, said tension monitors being operably connected to said stabilization controller for supplying tension information thereto. Advantageously, said platform includes one or more cable length monitors for monitoring the length of one or more of said cables, said one
30 or more cable length monitors being operably connected to said stabilization controller for supplying length data thereto.

The present invention also provides method for controlling a floatable platform having a platform base; a tower; a wind turbine mounted on said tower for angular movement relative thereto; a displacement sensor for determining the axial displacement of said platform about one or more axes; a stabilisation controller; and a yaw control mechanism wherein said method includes the step of controlling one or more of the pitch of the blades of said wind turbine and the yaw angle of the wind turbine relative to the base so as to correct for yaw motion of the platform.

According to a still further aspect of the present invention there is provided a control method for a platform including an oscillating water column having an airflow control mechanism, for controlling the flow of air through the oscillating water column; the method comprising the steps of monitoring the axial displacement of said platform relative to one or more axes and controlling the flow of air through said oscillating water columns in response to detection of a deviation from a desired axial orientation of said platform, thereby to raise or lower a portion of said platform relative to the water upon which it is floating and at least reduce movement in one of more axis. When said airflow control mechanism comprises a flow control valve said method preferably includes the step of controlling the flow of air through said one or more columns so as to cause a portion of said platform to rise or fall relative to an adjacent portion thereof. When the airflow control mechanism comprises an air driven turbine generator the control thereof may comprise the steps of controlling the backpressure created thereby within the column. When said airflow control mechanism comprises a flow control valve and an air driven turbine generator, said method may include the step of controlling the flow of air through said one or more columns and the backpressure created by the turbine so as to cause a portion of said platform to rise or fall relative to an adjacent portion thereof.

In some arrangements the platform may be provided with one or more horizontally extending water columns and said method may further include the step of controlling the flow of air through the water column for controlling the platform in one or more of sway or surge.

5

When said platform includes one or more cable anchors having power generators attached thereto said method may include the step of controlling the paying in and paying out of said anchor lines thereby to control the platform in one or more
10 of yaw, sway and surge. The said method may include the step of altering the pitch and/or excitation voltage of the air driven turbine within the oscillating water column in accordance with a given control methodology. The method may also include the step of altering one or more of the wind turbine rotor blade pitch and/or excitation voltage of the wind turbine generator in accordance with a given
15 control methodology. When said platform includes a computer having a software programme having a control algorithm said method may include the step of controlling one or more of the air pressure within one or more oscillating water columns, the yaw and pitch angle of one or more blades of a wind turbine and/or the paying in and paying out of one or more anchor lines.

20

The present invention will now be more particularly described by way of example only with reference to the accompanying drawings, in which:

Figure 1 is a plan view of a platform according to the present invention and
25 illustrating the juxtaposition of the wind turbine and the water columns;

Figure 2 is a cross sectional view in the direction of arrows A-A in figure 1 and better illustrates the association between the water columns and power generation systems associated therewith;

Figure 3 is a side elevation of the platform shown in figure 1 and illustrates
30 various degrees of movement thereof;

Figure 4 is a plan view of the tower and wind turbine arrangement and illustrates the corrective loading reaction force that can be applied to correct for platform yaw;

5 Figures 5 to 7 illustrate in more detail three alternative oscillating water column arrangements;

Figure 8 is a plan view of the platform and illustrates an arrangement for stabilising the platform relative to a more secure structure, such as the seabed;

Figure 9 is a diagrammatic representation of a control system used in the above-mentioned arrangements;

10 Figure 10 is a further cross sectional view of the platform of figures 1 to 3 and illustrates various options for the positional relationship of the water column and the turbines positioned thereon; and

Figure 11 is a graph of oscillation frequencies.

15 Referring now to the drawings in general but particularly to figure 1, it will be appreciated that a platform 10 according to the present invention comprises a base 12 within which may be provided a plurality of oscillating water columns (OWC's) shown diagrammatically at 14 and upon which may be provided a wind turbine shown generally at 16 and being rotatable about axis A. In various
20 arrangements one or more or both of the OWC's and wind turbine may be provided. When floating on water and exposed to the motion of the waves and other influences the platform can move about three axis in one or more of six ways (pitch, roll, yaw, sway, surge and heave), all of which are discussed in detail later herein but each of which are marked with appropriate arrows (P, R, Y, Sw, Su and H) throughout the drawings. The OWC's may be provided in the singular, matched pairs at opposite extremities of the platform or in multiples thereof positioned at appropriate positions within the platform depending upon the function to which they are to be allocated. As discussed above, OWC's are well known for use in generating power from the motion of waves passing under
25 such platforms. Such columns generally comprise an axially extending tube 18 exposed at one end 20 to the water beneath the platform and having at an

otherwise free end 22 an air powered turbine generator system often provided in the form of, for example, a Wells turbine 24. Such turbines have a fixed or a variable pitch rotor 26 and are "bi-directional" in that the generator portion thereof 28 turns in the same direction regardless of the direction of the rotor portion 26.

5 Such turbines lend themselves well to use in OWC's as an air column positioned above the water column within the tube 18 is forced up and down past the turbine blades as the level of water rises and falls with the passing waves and this motion turns the blades in opposite directions. The wind turbine portion of the arrangement 16 is generally mounted on a tower 32 best seen in figure 3 and
10 includes a drive mechanism 34 for altering the angular position θ (fig 4) or direction of the rotor blade 36 relative to the platform base 12 and this is normally used to position the rotor directly into wind so as to capture the maximum amount of wind energy. Such wind turbines also include a variable pitch propeller arrangement 38 and a control system 40 for altering the pitch thereof.

15

Thusfar, we have described a conventional OWC and wind turbine arrangement. The present invention improves on the above-arrangements in a number of ways, each of which will be discussed in detail below.

20

One of the first improvements that the present invention provides is the form of stabilization of the platform within which the OSC's are positioned. In this context the present arrangement is provided with an air flow control mechanism 50 which, in one arrangement, comprises an airflow control valve 52 (fig 5) and in another arrangement comprises a system 54 for controlling the pressure drop
25 across the air driven turbine blades 26, both of which will be described in detail later herein. The airflow control mechanism 32 is operated and controlled from a computer 56 having a software programme 58 including an algorithm 60 for reactive or adaptive control of the control mechanism according to a pre-determined control strategy or an adaptive control strategy, each of which are
30 also described in more detail later herein. The airflow control mechanism is controlled in order to control the flow of air through the OWC's and thus control

the stability of the platform in one or more of Pitch, Roll, Surge and Sway. Control of yaw is facilitated by altering the angle of the wind turbine 16 relative to the platform base 12, again as will be described further later herein. An additional control function can be implemented to control or further control the pitch of the platform 12 by altering the pitch angle of the rotor blades of the wind turbine 16 or altering the electrical load on the generator 64 associated therewith. Again, this control is implemented via the computer and will be described in more detail later herein.

10 Referring now to figures 5 to 7 from which it can be seen that the OWC's can be provided in a number of different forms. The example of figure 5 illustrates an arrangement in which the water column 64 supports a floating ball 66 which, in operation, is driven up and down the column as the water rises and falls in accordance with the height of any passing wave. Positioned towards the top of the column is a restrictive orifice 68 formed by projections 70 shaped and positioned such as to prevent the ball 66 passing therethrough. In the event of the water column rising too far up the chamber the ball closes off the orifice and prevents water from entering the turbine blade section in which it can cause overloading of said blades and damage to them and the generator system through shock loading. Towards the top of the column is an airflow control valve 52 linked for control thereof to actuator 72 which is, in turn, linked to controller 56 for operation as described later. An alternative arrangement is shown in figure 6 in which the floating ball 66 is replaced by a floating plate valve 74 and projections 76 which form a restrictive orifice 54 through which said plate valve 60 can not pass. Operation is as described above and is not, therefore repeated herein. Whilst not necessary in all applications, the arrangement may also include an airflow control valve 52 and actuator as described above. A third arrangement is illustrated in figure 7 in which a sliding plate valve 76 and actuator 78 are employed to obviate orifice 54 defined by restricting projections 80. Again, valve 52 and actuator 72 may be employed if so desired. Shown in each of drawings 5 to 7 are pressure sensors 82 for sensing the air pressure within the

column. Such sensors may be provided in pairs 82a, 82b on either side of the rotor blades 26 so as to determine the pressure drop thereacross. Each pressure sensor is operably connected via line 90 to the stability controller 56 for delivering pressure data thereto. Within each OWC there is also provided a water level sensor 92, each of which is also operably connected via line 94 to controller 56 for delivering water level data thereto. Other sensors provided within the system include a wave sensor 96 (fig 3) for monitoring the frequency and height of incoming waves and a wind sensor 98 for determining the wind speed, variation and direction. Each of these sensors are connected by lines 100, 102 to said controller for providing wave and wind data thereto. The wind turbine 16 is provided with an RPM sensor 104 and an angular position sensor 106 for determining the speed of rotation of the rotor blade and the angular position of the rotor relative to the base portion 16. Again, each of these sensors is connected to the controller 56 via lines 112, 114 (fig 9) for providing data thereto. Each of the air driven generators 28 within the OWC's and the wind turbine 16 are provided with Voltage and Current monitors and controllers shown schematically at 116 and 118 respectively and being linked by lines 96 and 98 respectively for transmitting Voltage and Current data thereto and for receiving control signals therefrom for controlling the generators themselves. Each controller 112, 114 is preferably configured to control the excitation voltage of each generator.

The skilled reader will appreciate that the OWC's may be provided in the singular, in pairs, around the periphery of a platform, along one or more edges, within the core of the platform or any combination thereof. Additionally, the OWC's may be operated individually, in pairs or in groups so as to assist with the stabilisation / power generation requirements. When operating in pairs, it has been found that operation (control) of pairs placed diametrically opposite to each other is advantageous as the OWC's can be used in a "cross-linked" manner allowing data from one OWC to be used when controlling another or two OWC's to be controlled based on data from two or more OWC's or other sensors. Other

arrangements will present themselves to those skilled in the art and throughout the present description reference to single OWC's should be considered as a reference to one or more such devices.

5 Central to the control system described above is a motion sensor 118 of figure 3 able to detect motion in the form of displacement, acceleration or movement in or about any one of one or more axes X, Y, Z so as to determine the degree of pitch, roll, yaw, sway, surge and heave as and when necessary in order to provide the controller 56 with motion data for subsequent use in control
10 processes. Such devices are well known in the art and are, therefore, not described further herein save to say they may comprise a simple solid state device sensitive to motion or acceleration in any one of one or more axes and generally provide a digital or analogue output proportional to the measured motion which may be transferred to the controller 56 in the usual manner.
15 Preferably, the sensor 118 is positioned close to the centre of the platform base 12 so as not to experience excessive motions but it may be positioned anywhere on the platform or even the tower 32 itself.

The reader's attention is now drawn to one final stability/power generation
20 arrangement of the present invention which is shown in figure 8 in which the base 12 is provided with an anchor mechanism shown generally at 120 comprising three or more anchor lines 122 secured at a first end to an immovable object 124 such as the sea bed and at an otherwise free end to a power generation device 126 which will be described in more detail shortly. The arrangement is provided
25 with a tension monitor 128 for monitoring the tension in each line and this data is fed to controller 56 by data lines 130 to 136 (fig 9). The generator 126 provides an anchor point for the line and a drum 138 located on the shaft of said generator acts to store an amount of line and accommodate "paying in" and "paying out" of said line as and when required. The generators each includes a Voltage and
30 Current monitor 140 and controller 142 for monitoring the Voltage and Current and for controlling the generator in the manner described above in relation to the

wind and OWC generators. Data and instructions may be provided to the controller 56 and received therefrom via lines 130 to 136. It will be appreciated that as the platform moves in synch with any wave or wind force acting thereon the cables will wind on and off the drums thus causing the drum to rotate and turn the generator with it and thus generate electrical power. The amount of power generated will vary depending upon the control of the generator and the amount of tension the individual lines experience. The electrical load may be altered or controlled as described above in order to maintain a given tension on the line (and hence platform stability) or may be used to control the tension and platform stability within given tolerances.

The reader's attention is now drawn to figure 9 which illustrates the control system that may be employed with the arrangement described herein. It should be noted that one or more of such control systems may be employed and said control systems may be employed to operate in parallel, in which case they are each provided with all inputs and control outputs and act as back-up systems to each other. Alternatively, each of multiple control systems may be employed to control one or more movement of the platform. One arrangement a singular control system may be provided for yaw control whilst a further may be provided for platform stability. Referring now more particularly to figure 9, it will be appreciated that the multiple inputs from each of the sensors or detectors 82, 92, 96, 104, 106, 112, 114, 116, 118 and 140 are fed via lines 94, 96, 98, 100, 102, 112, 114, 130, 132, 134 and 136 to controller 56 having a software programme 58 including (if desired) an algorithm 60 for reactive or adaptive control of said platform. A multiplexer or other such device 150 may be employed to combine the signals or inputs. The controller operation is described in detail in other portions of this document so is not further described here save to say that it may employ a feedback control loop shown schematically by arrow 152. Once the input data has been analysed and considered by the controller a control output is provided via line 156 to signal processor 158 (if desired) and then to data /

control lines before being supplied to the various controllable elements for control thereof so as to control the platform within the desired set control limits.

5 Figure 10 shows slightly different arrangements of the OWC in which the column exit is positioned at the edge of the platform 12a rather than the base thereof. Such arrangements allow for the use of side impact of any waves in the generation of power / for stabilisation control. The column 18a is shown as a straight column angled relative to the edge whilst column 18b is a smooth curve arrangement.

10 Referring now to figure 11 which is a graphical representation of a number of the various forces that the platform will experience, it will be appreciated that the magnitude and direction of the forces, loads and motions discussed above may vary and may act in phase or out of phase with each other. For reasons of clarity we illustrate just three forces namely wave force W_A , mooring yaw force M_Y and
15 wind gust force W_G although any one of the forces monitored by the various sensors may be incorporated into the system. Each of these forces will have a frequency (F_1 , F_2 and F_3) which might remain substantially constant in the case of wave frequency or may vary dramatically in the case of wind gust frequency. In practice it is possible for the various forces to combine together in certain
20 circumstances and, if so, the resultant force can be greater than the design maximum allowed for the structure or stability requirements and must be avoided. The magnitude, frequency (F_1 to F_3) and rate of change of each force is fed to the controller 56 and analysed thereby and the magnitude, rate and displacement from a given stable position determined for any given moment in time. The
25 controller has a primary responsibility to maintain the stability of the platform within given boundaries but whilst doing so also operates to maximise or at least optimise the combination of stability and power generation. There are some degrees of motion that are best eliminated in order to maximise stability and power generation and other degrees of motion that may be accommodated as
30 they are within the design or stability tolerances of the platform itself. One of the functions of the controller 56 is to receive all the motion and force data and cause

initiation of stabilization control according to a pre-determined set of rules or an adaptively learnt set of rules stored within a look up table or memory, written into an algorithm or otherwise available to the controller. Of particular importance is the provision of a monitoring function which monitors each of the forces and initiates control as and when necessary in order to avoid the combined effect of multiple external forces. In this arrangement control to dampen down movement in one or more directions is initiated in a predictive manner so as to avoid excessive loading created by the combined forces. Such a "predictive" system would assist with the elimination of frequencies of forces which might combine together to create a frequency matching that of the resonant frequency of the platform or structure itself. Various limits may be selected so as to define an "envelope" of operation. One such limit might be the maximum acceleration of the wind turbine at the top of the mast as any excessive acceleration could place unacceptable loads on the tower and turbine itself. Another might be the maximum angle of pitch or rate of pitch change whilst a still further limit would be the maximum degree of roll and roll rate. Indeed, each and every one of Pitch, Roll, Sway, Yaw, Surge and Heave may have a maximum value and a maximum rate of change that is incorporated in the system so as to define the "envelope" of control parameters. When maximum platform stability is required one need only to alter the control criteria so as to limit the degree of movement from a relatively flat and stable position upon the sea so as to ensure corrective stabilization action is taken whenever necessary. In some other arrangements it may well be acceptable to allow a higher degree of motion and, indeed, one can in some instances make very good use of such motion. One example would be the pitching of the platform forwards and backwards into and out of the wind driving the wind turbine. One can extract more energy from the wind as the turbine and blades pitch forward as the blades themselves experience both the real and the apparent wind which, in combination, provide a higher energy opportunity. If the pitch of the blades or the loading on the turbine generator is altered accordingly, the blades will not only extract more energy from the wind but they will also provide more resistance to the wind and this can be used as a reactive force

helping balance or stabilise the platform itself. Such control is of particular advantage when trying to extract maximum energy from the wind whilst accepting less stabilization of the platform. The control of air through the OWC's can also be used to stabilise the platform and/or optimise power or indeed maintain stability within acceptable limits whilst optimising power generation. In operation the air control valve or the pressure drop across the turbine blades is controlled to increase or decrease the air pressure within any associated column such as to cause the portion of the platform adjacent thereto to rise or fall relative to adjacent portions of the platform by virtue of the upward force created by the air pressure itself. When the side entry OWC arrangements of figure 10 are employed these may be employed to good effect to control both sway and surge as water entering these columns will be used to generate power as opposed to reacting against the side of the platform and inducing sway or surge motion.

Another area of stability control resides in Yaw control. Whilst this may be achieved by prudent control of the anchoring cables and generators associated therewith, it may also be achieved by altering the angular relationship between the wind turbine and the tower / base upon which it is mounted. In this aspect the yaw sensor is used to detect yaw of the platform and an output is fed to the controller which operates according to the pre-defined or adaptive control provided therein to initiate control over drive mechanism 34. The mechanism is actuated so as to angle the rotor at an angle θ and create a sideways force F_y (fig 4) which acts to sway the platform around its vertical axis A so as to correct any detected yaw in the platform. This control may be provided independently of any other control or in combination therewith and is preferably operated dependent upon data received from more than just the yaw sensor so as to allow for "intelligent" control which accommodates movement or alterations happening in other directions other than yaw and accommodates or controls according to predicted movements that can be predicted by, for example, monitoring changes in wind or wave conditions.

From the above discussion it will be appreciated that each of the controllable elements of this arrangement (OWC's, wind turbine and cable anchors) may be operated either independently or in combination with one or more of the remainder. Indeed, the controller 56 itself being in receipt of all the motion, wave, wind, electrical load, RPM and other information may employ this data to good effect to control one or more of the controllable elements in order to maximise stability in preference to power generation, maximise power generation whilst keeping stability and mechanical loads within accepted limits or some compromise between these two limits. Additionally, as a number of the controllable elements will, when controlled, have an affect on more than just one motion, each may be used in combination to tackle individual or compound motions.

15

Claims:

1. A floatable platform comprising:
a platform base;
5 a motion sensor for determining the axial motion of said platform about or along one or more axes;
a stability controller;
a tower;
a wind turbine mounted upon said tower, said turbine having a propeller and a rotational mount upon which said turbine is mounted for rotational movement
10 about a longitudinal axis of said tower;
said motion sensor including a yaw detector for detecting the angular yaw position of the platform and being operably connected to said stability controller for supplying yaw data to said controller; and
15 a yaw actuator for varying the yaw angle of the turbine relative to said tower, said yaw activator being operably connected to said stability controller for receiving actuation signals therefrom, thereby to vary the angular position of said wind turbine relative to said tower.
- 20 2. A platform as claimed in claim 1 including a wind monitor for monitoring the direction and velocity of any wind approaching said platform, said wind monitor being operably connected to said stabilization controller for supplying wind data thereto.
- 25 3. A platform as claim 1 or 2 including a pitch controller for controlling the pitch of said rotor blades, said pitch controller being operably connected to said stabilization controller for receiving control signals therefrom.
- 30 4. A platform as claimed in any one of claims 1 to 3 and further including an RPM sensor for monitoring the speed of rotation thereof, said RPM sensor being operably connected to said stability controller for delivering rotational speed data thereto.

5. A platform as claimed in any one of claims 1 to 4 including a Voltage and Current sensor for monitoring Voltage and Current output of said generator, said sensor being operably connected to said stability controller for delivering Voltage and Current data thereto.

6. A platform as claimed in any one of claims 1 to 5 and having a wind driven generator and including an excitation voltage controller for controlling the excitation voltage of said generator.

7. A platform as claimed in claim 6 wherein said excitation voltage controller is operably coupled to said stability controller for control thereby.

8. A platform as claimed in any one of claims 1 to 7 including:
an oscillating water column;
an air flow control mechanism, for controlling the flow of air through the oscillating water column; wherein said axis sensor is operably connected to said stabilisation controller for transmitting axial motion data to said control and said control is operably connected to said airflow control mechanism for controlling the flow of air through said oscillating water column, thereby to at least partially stabilise said platform in one or more axes.

9. A platform as claimed in claim 8 wherein said airflow control mechanism comprises a flow (pressure) valve for controlling the flow of air through the column.

10. A platform as claimed in claim 8 or 9 wherein said airflow control mechanism comprises an air driven turbine and a control mechanism for controlling the back pressure created thereby within the column.

11. A platform as claimed in any one of claims 8 to 10 and having two oscillating water columns, said oscillating water columns positioned at opposite ends of said platform to each other and each being operably connected to said stabilisation controller for control thereby.

5

12. A platform as claimed in any one of claims 8 to 11 and comprising a plurality of oscillating water columns along each of said ends.

13. A platform as claimed in any one of claims 8 to 12 and having two
10 oscillating water columns, said oscillating water columns positioned at opposite sides of said platform to each other and each being operably connected to said stabilisation controller for control thereby.

14. A platform as claimed in any one of claims 8 to 13 and comprising a
15 plurality of oscillating water columns along each of said sides.

15. A platform as claimed in any one of claims 1 to 14 wherein said displacement sensor comprises a multi-axis displacement sensor.

20 16. A platform as claimed in any one of claims 1 to 15 wherein said multi-axis displacement sensor monitors axial displacement in one or more of roll, pitch, yaw, heave, sway and surge of the platform.

25 17. A platform as claimed in any one of claims 1 to 16 wherein said stabilisation controller includes a computer having a software program operable to control the stability of the platform in accordance with a pre-determined control strategy.

30 18. A platform as claimed in any one of claims 1 to 17 wherein said stabilisation controller includes a feedback control.

19. A platform as claimed in any one of claims 8 to 18 wherein said water column or columns further include a surge prevention mechanism.

20. A platform as claimed in claim 19 wherein said surge prevention mechanism comprises a floating ball and means defining a restricted orifice having a diameter smaller than said ball.

21. A platform as claimed in claim 19 wherein said surge prevention mechanism comprises a floating plate having an external diameter and means defining a restricted orifice having a diameter smaller than that of said plate.

22. A platform as claimed in claim 19 wherein said surge prevention mechanism comprises a sliding plate valve having an actuator and means defining an orifice over which said plate valve is slid by said actuator.

23. A platform as claimed in any one of claims 8 to 22 and further including a pressure sensor within one or more oscillating water columns, said pressure sensor being operably connected to said stability controller for delivering pressure data thereto.

24. A platform as claimed in claim 23 wherein said pressure sensor includes a sensor on each side of a wind turbine blade positioned therein, thereby to determine the pressure differential across the turbine.

25. A platform as claimed in any one of claims 8 to 24 and further including a water level sensor within one or more oscillating water columns, said level sensor being operably connected to said stability controller for delivering pressure data thereto.

26. A platform as claimed in any one of claims 8 to 25 and further including a wave sensor for determining the height, direction and frequency of waves, said

wave sensor being operably connected to said stability controller for delivering wave data thereto.

27. A platform as claimed in any one of claims 1 to 26 and further including an anchor mechanism for anchoring said platform to an immovable object.

28. A platform as claimed in claim 27 wherein said anchor mechanism comprises three or more anchor lines secured at a first end to an immovable object and at an otherwise free end to a power generation apparatus.

29. A platform as claimed in claim 28 and including one or more cable tension monitors for monitoring the tension in one or more of said cables, said tension monitors being operably connected to said stabilization controller for supplying tension information thereto.

30. A platform as claimed in either of claims 28 or 29 and including one or more cable length monitors for monitoring the length of one or more of said cables, said one or more cable length monitors being operably connected to said stabilization controller for supplying length data thereto.

31. A control method for controlling a floatable platform having a platform base; a tower; a wind turbine mounted on said tower for angular movement relative thereto; a displacement sensor for determining the axial displacement of said platform about one or more axes; a stabilisation controller; and a yaw control mechanism wherein said method includes the step of controlling one or more of the pitch of the blades of said wind turbine and the yaw angle of the wind turbine relative to the base so as to correct for yaw motion of the platform.

32. A control method as claimed in claim 31 for a platform including an oscillating water column having an airflow control mechanism, for controlling the flow of air through the oscillating water column; the method comprising the steps

of monitoring the axial displacement of said platform relative to one or more axes and controlling the flow of air through said oscillating water columns in response to detection of a deviation from a desired axial orientation of said platform, thereby to raise or lower a portion of said platform relative to the water upon
5 which it is floating and at least reduce movement in one of more axis.

33. A control method as claimed in claim 32 wherein said airflow control mechanism comprises a flow control valve and said method includes the step of controlling the flow of air through said one or more columns so as to cause a
10 portion of said platform to rise or fall relative to an adjacent portion thereof.

34. A control method as claimed in claim 32 or 33 and when the airflow control mechanism comprises an air driven turbine generator wherein control thereof comprises the steps of controlling the backpressure created thereby within the
15 column.

35. A control method as claimed in any one of claims 32 to 34 and when said airflow control mechanism comprises a flow control valve and an air driven turbine generator wherein said method includes the step of controlling the flow of
20 air through said one or more columns and the backpressure created by the turbine so as to cause a portion of said platform to rise or fall relative to an adjacent portion thereof.

36. A control method as claimed in any one of claims 32 to 35 and when said
25 platform is provided with one or more horizontally extending water columns wherein said method further includes the step of controlling the flow of air through the water column for controlling the platform in one or more of sway or surge.

37. A control method as claimed in any one of claims 32 to 36 and when said
30 platform includes one or more cable anchors having power generators attached thereto wherein said method includes the step of controlling the paying in and

paying out of said anchor lines thereby to control the platform in one or more of yaw, sway and surge.

38. A control method as claimed in any one of claims 31 to 37 wherein said
5 method includes the step of altering the pitch and/or excitation voltage of the air driven turbine within the oscillating water column in accordance with a given control methodology.

39. A control method as claimed in any one of claims 31 to 38 wherein said
10 method includes the step of altering one or more of the wind turbine rotor blade pitch and/or excitation voltage of the wind turbine generator in accordance with a given control methodology.

40. A method as claimed in any one of claims 31 to 39 when said platform
15 includes a computer having a software programme having a control algorithm and said method includes the step of controlling one or more of the air pressure within one or more oscillating water columns, the yaw and pitch angle of one or more blades of a wind turbine and/or the paying in and paying out of one or more anchor lines.

20

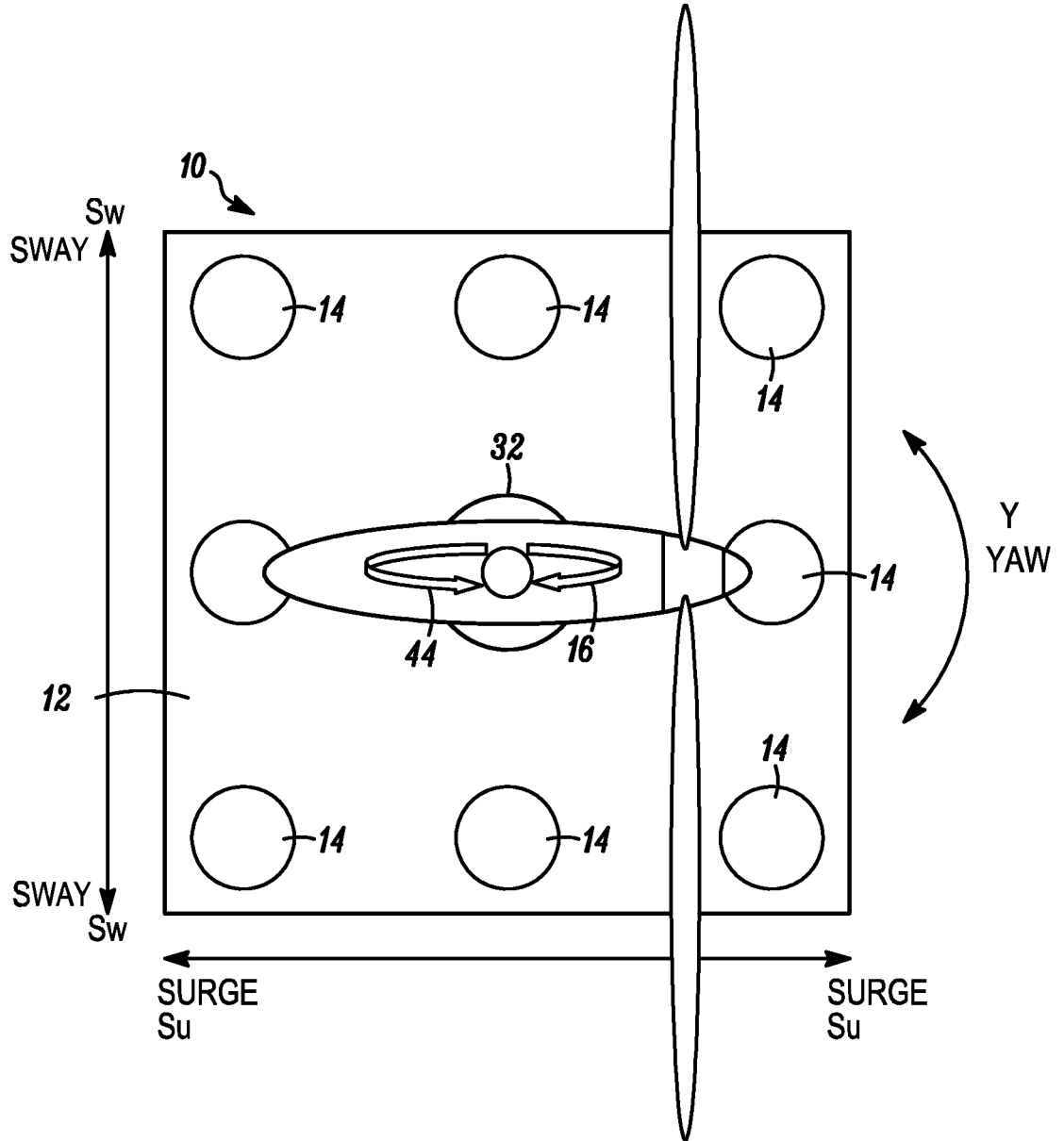

FIG. 1

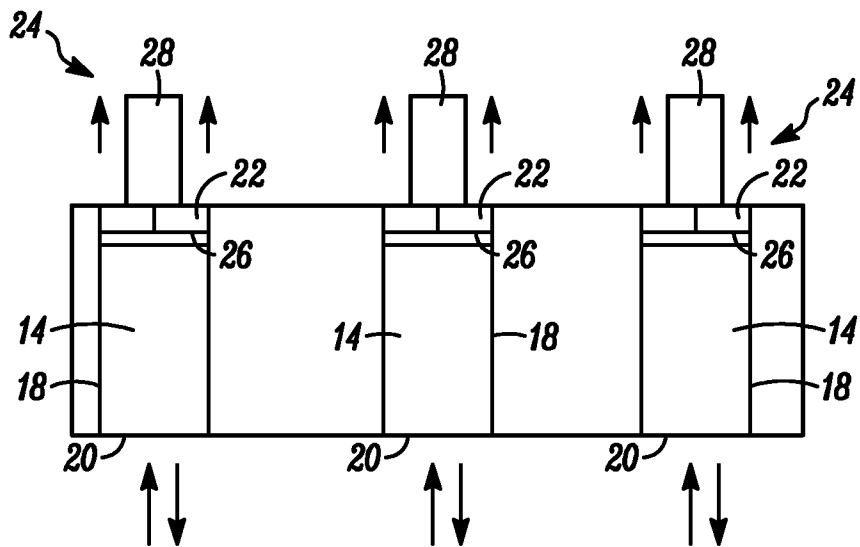

FIG. 2

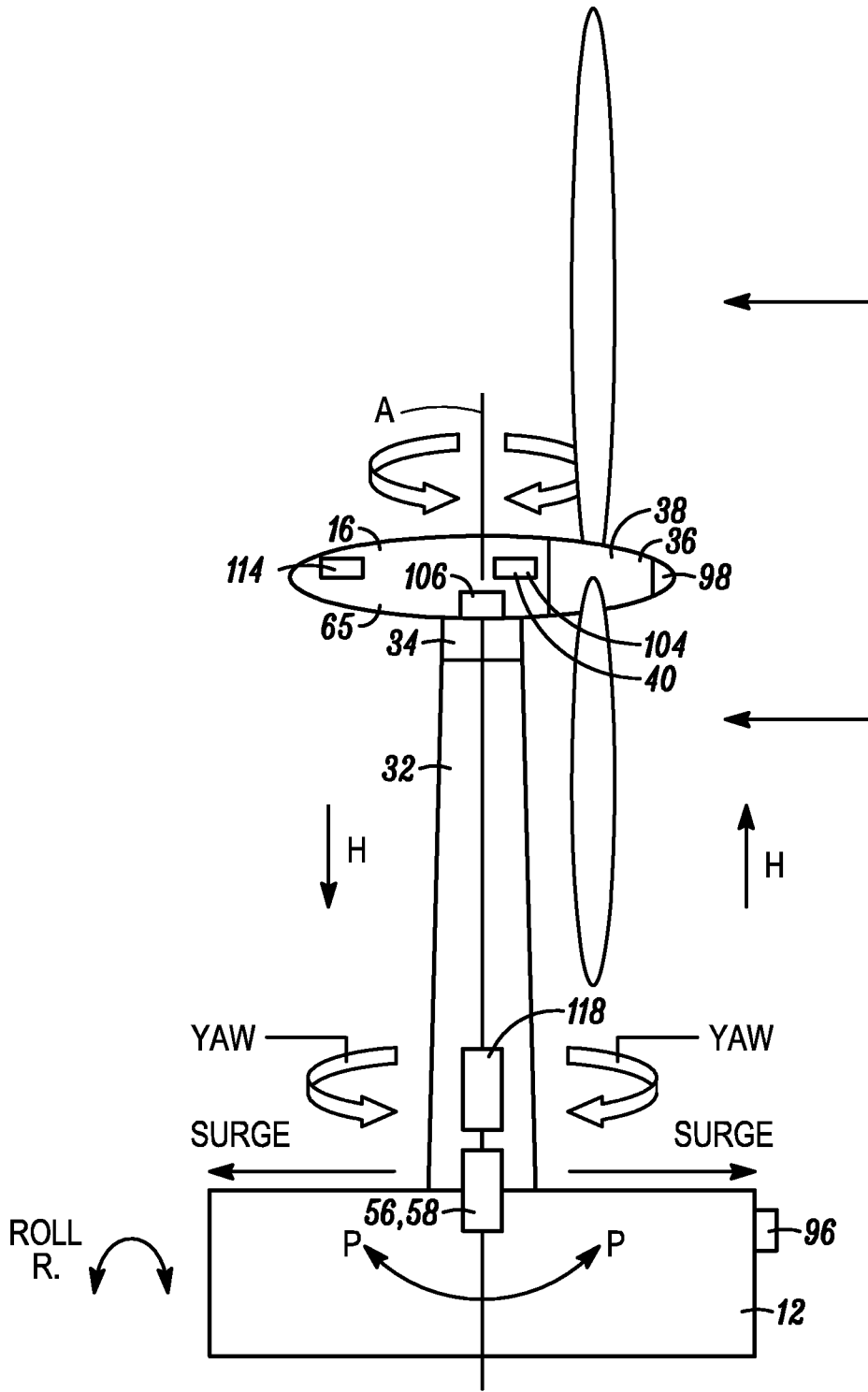

FIG. 3

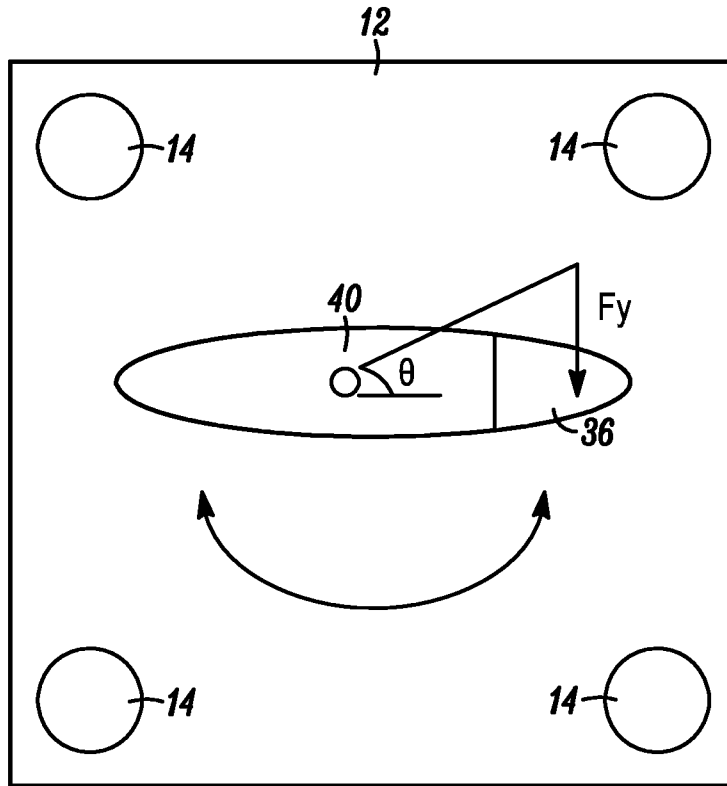

FIG. 4

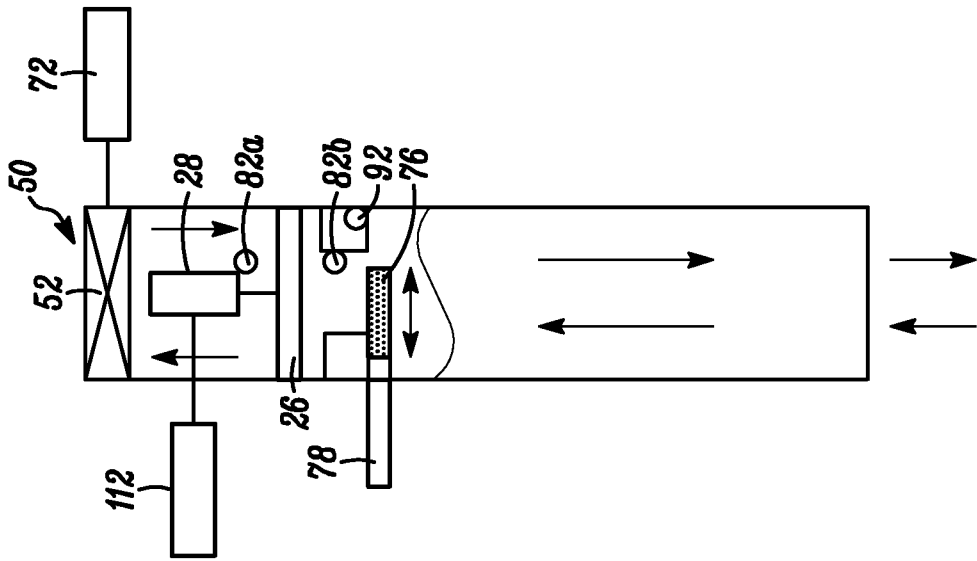

FIG. 5

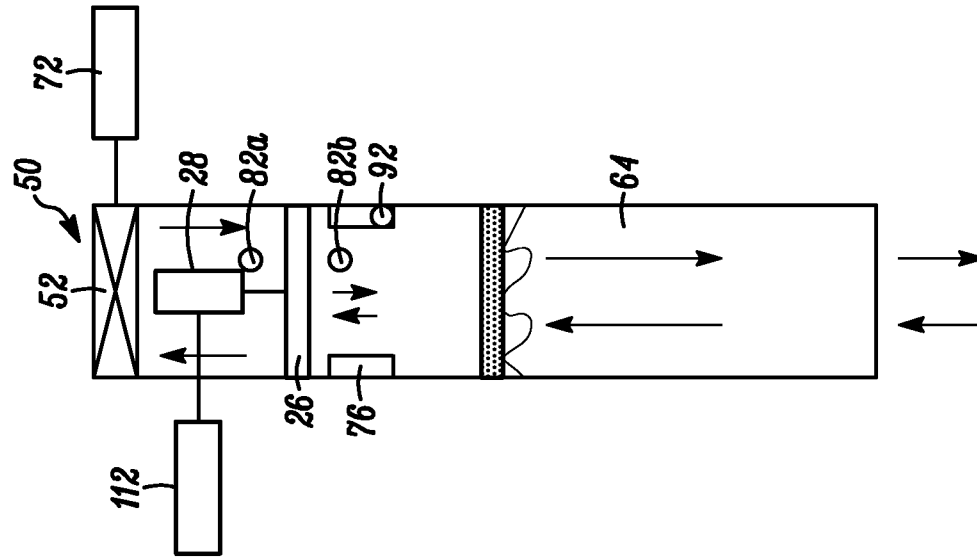

FIG. 6

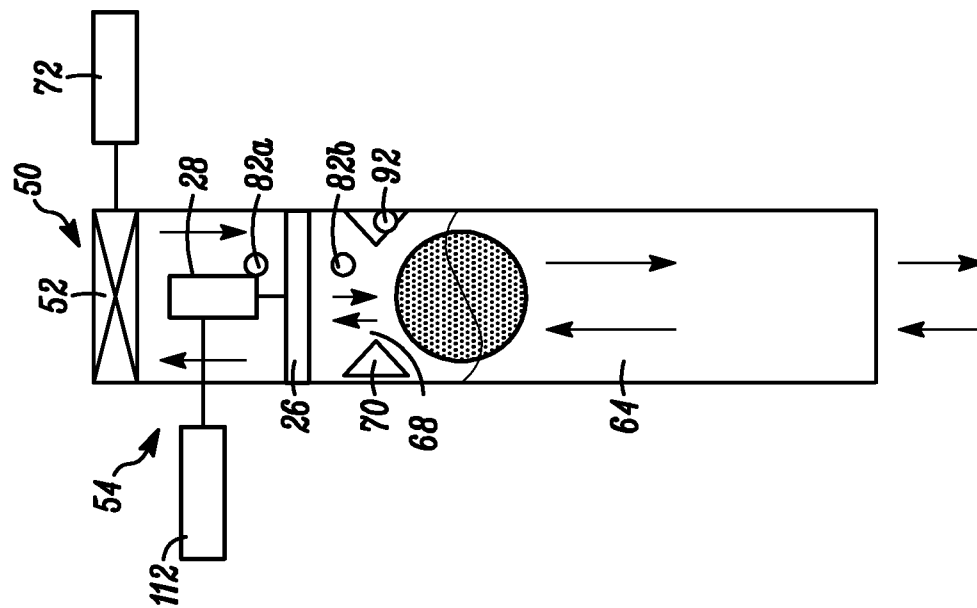

FIG. 7

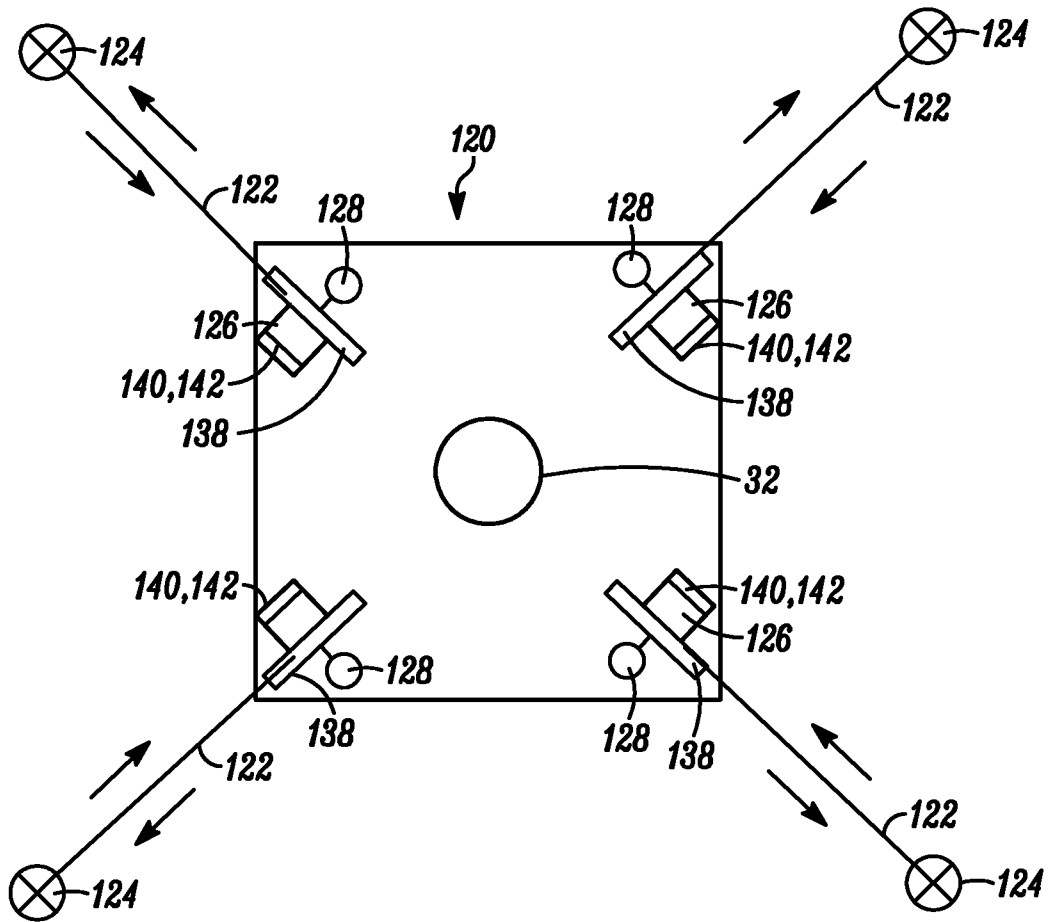

FIG. 8

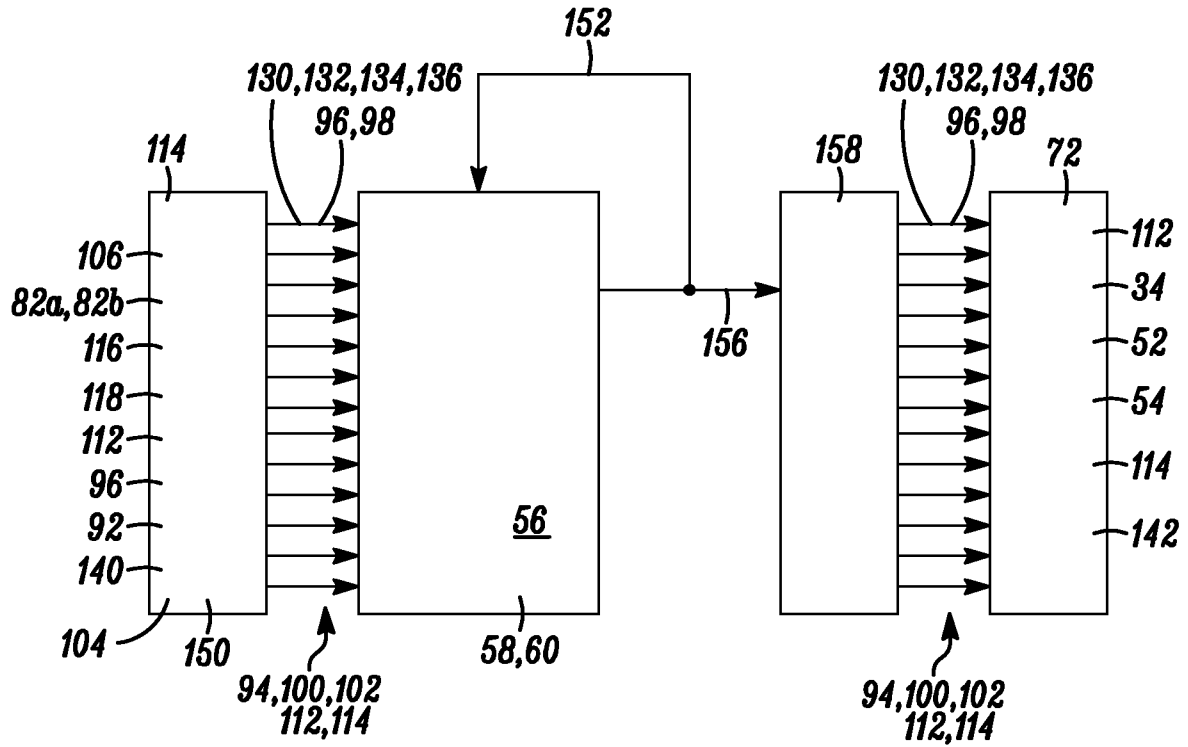

FIG. 9

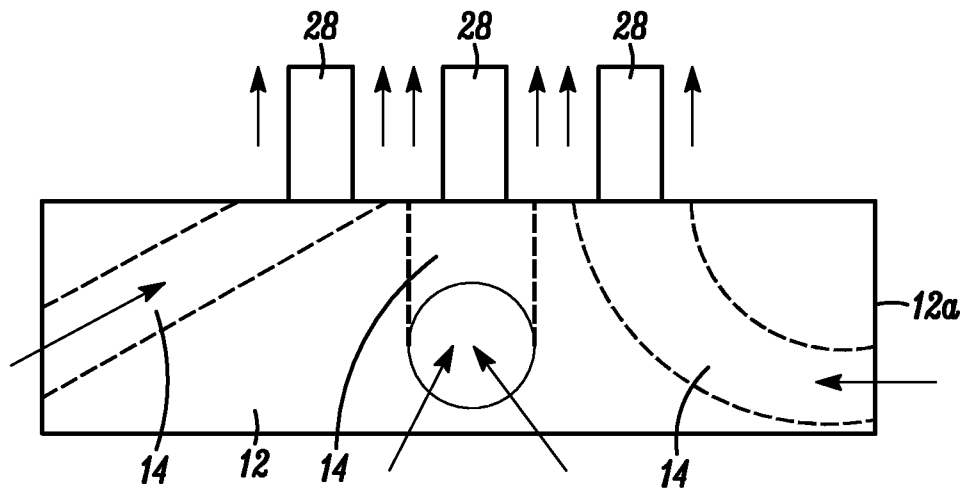

FIG. 10

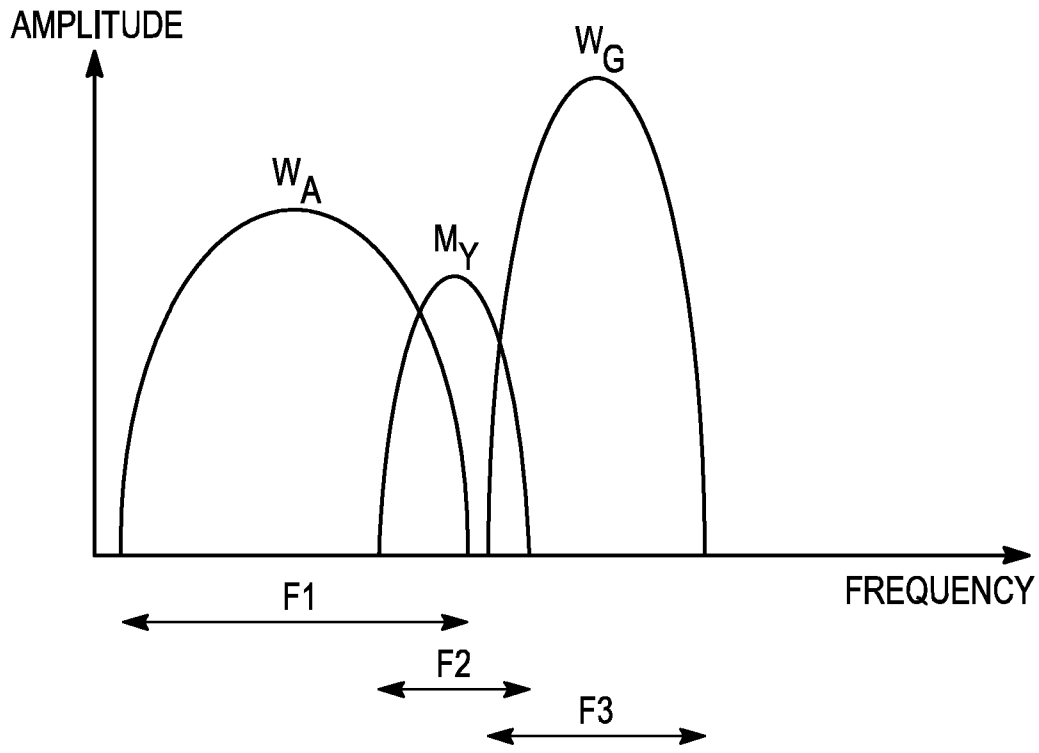

FIG. 11