

Dec. 3, 1935.

F. CONRAD ET AL

2,023,065

MOTION PICTURE APPARATUS

Filed May 1, 1930

2 Sheets-Sheet 1

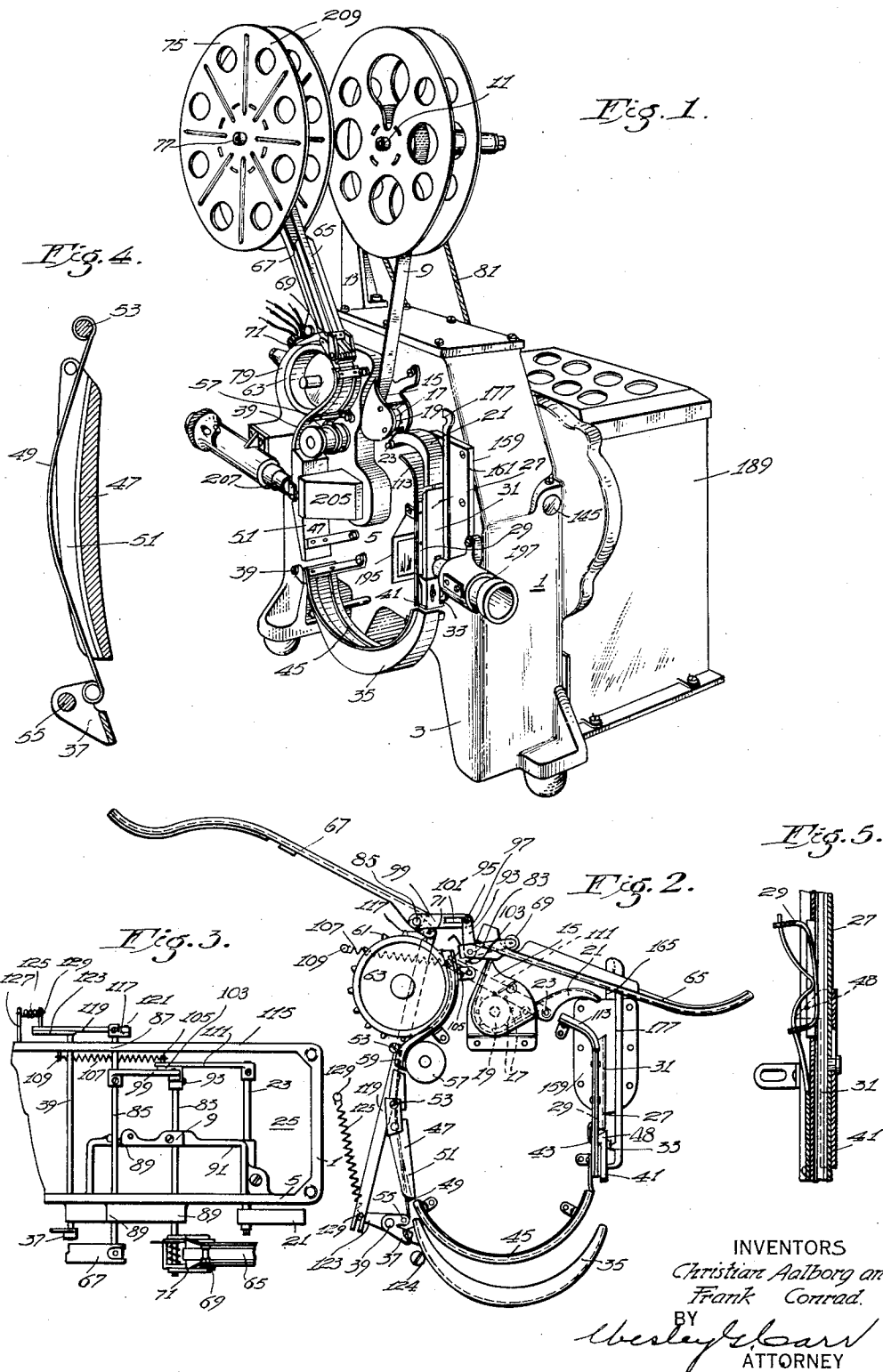

INVENTORS
Christiane Aalborg and
Frank Conrad.
BY
Wesley C. ...
ATTORNEY

Dec. 3, 1935.

F. CONRAD ET AL

2,023,065

MOTION PICTURE APPARATUS

Filed May 1, 1930

2 Sheets-Sheet 2

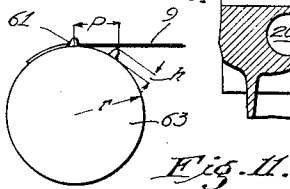
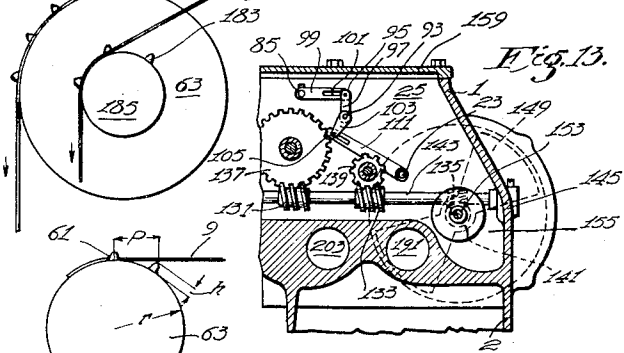
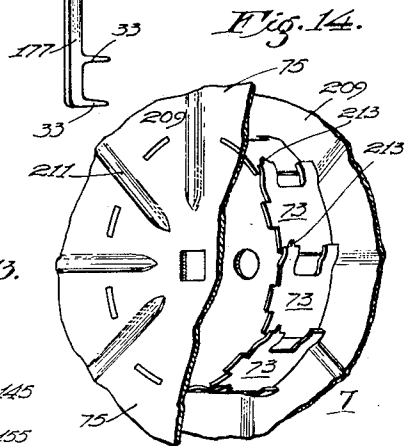
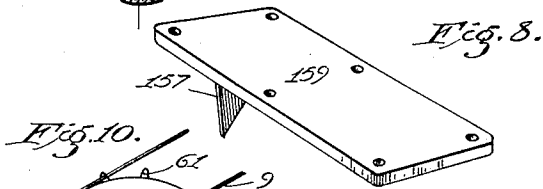
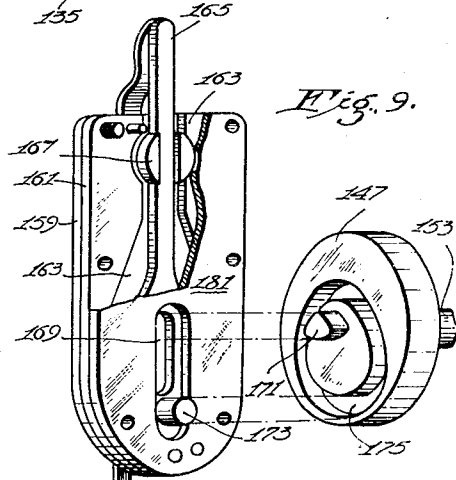
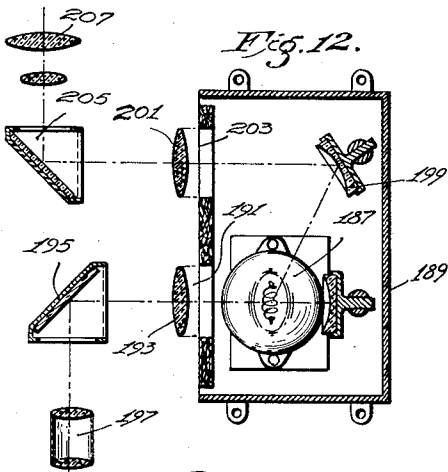
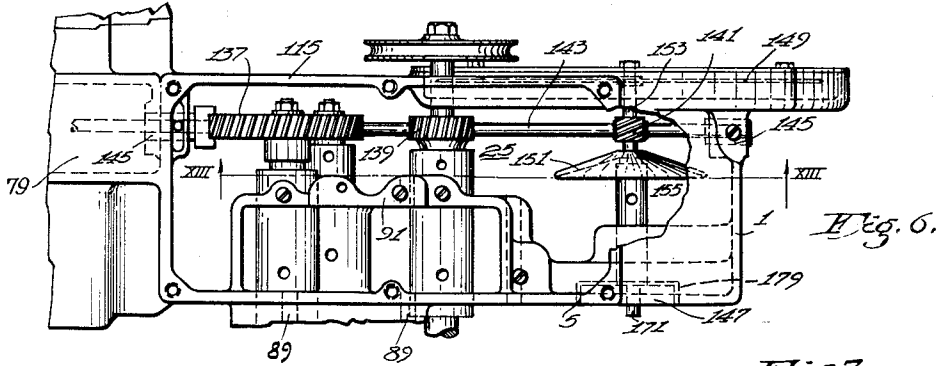

INVENTORS
Christian Aalborg and
Frank Conrad.
BY
Wesley C. Carr
ATTORNEY

UNITED STATES PATENT OFFICE

2,023,065

MOTION PICTURE APPARATUS

Frank Conrad, Wilksburg, and Christian Aalborg, Pittsburgh, Pa., assignors to Westinghouse Electric and Manufacturing Company, a corporation of Pennsylvania

Application May 1, 1930, Serial No. 449,024

9 Claims. (Cl. 88—16.2)

Our invention relates to acousto-cinematographic apparatus and has particular relation to domestic equipments of this type.

The film that is used in a domestic machine is not, ordinarily, the property of the owner of the machine but is supplied to him by a film-library to which he pays a certain rental for the use thereof. Since the domestic films, thus available to the consumer, are, in general reduced prints of the commercial films, it is possible for the owner of a domestic machine to see the films, that are available for his apparatus, at his neighborhood moving-picture house, by paying a nominal price of admission.

The rental that it is necessary to charge for the use of the films, and, consequently, the durability of the film is, therefore, an important fact to be considered in determining whether the domestic motion-picture venture will be a success or a failure.

The length of life of the film depends on its intrinsic strength and on the handling that it receives in the machine. Since the film per se has elastic properties that are far from satisfactory in this connection, it must be manipulated in the machines with considerable care, which is enhanced by the presence of a photo-acoustic sound attachment on the machine.

On the other hand, it is highly doubtful that the owner of a machine will restrict its operation only to the mechanically skillful members of his family. It is, furthermore, certain that the whole domestic motion-picture venture will fail if the consumer is required to pay for film mangled by his machine. A domestic motion-picture machine, therefore, of the type that is substantially "fool-proof" and practically incapable of causing injury to a film, even when operated by a totally unskilled person, is highly desirable. Such machine should be self-threading, and the various component parts thereof should be so interrelated that the sequential operation thereof is automatic.

Automatic-threading motion-picture machines constructed according to the teachings of the earlier prior art with which we are familiar have generally required manual operation for the provision of a loop-reservoir and for the application of pressure on the film after it has been threaded.

In machines of this type, the loop-formers are opened and the gates are closed after the film is positioned, and considerable damage is done to the film by careless operators who forget to provide for the loop-space before applying power for the actual projection of the picture.

Machines constructed according to the teachings of the later prior art are equipped with automatically operative loop-formers. It is obvious, however, that, to function properly, the automatic threading devices on machines of this type must be kept permanently lubricated. The provision of oiling facilities that shall not depend upon the constant attention of an operator is thus imperative for the successful operation of these machines. Such feature has not, so far as we are aware, been incorporated in the machines of the prior art.

It is, accordingly, an object of our invention to provide, for acousto-cinematographic apparatus, a completely automatic threading system that shall require, for its manipulation, a minimum degree of mental and physical exertion on the part of an operator.

An additional object of our invention is to provide, for an acousto-cinematographic machine, an automatic-threading system that shall be kept permanently lubricated and require no attention in this connection from the owner.

An ancillary object of our invention is to provide an acousto-cinematographic machine wherein the power-transmission parts are kept in a permanent state of lubrication.

A further object of our invention is to provide an acousto-cinematographic machine capable of producing sound of a good quality.

Still another object of our invention is to provide for a cinematographic machine power-delivery mechanism and an intermittent movement that are silent and smooth in their operation.

More precisely stated, it is an object of our invention to provide a simple and compact acousto-cinematographic machine capable of delivering entertainment of good quality, and one that shall be so nearly fool-proof in its operation as to require a minimum degree of mechanical ability on the part of the operator.

According to our invention, we provide acousto-cinematographic apparatus wherein the power-transmission elements are disposed in a chamber through which a lubricating fluid is kept constantly circulating. We, further, provide for the apparatus, an automatic threading device wherein the loop-formers and gates are operated by the film as it is wound on the take-up reel and which is provided with a plurality of motivating shafts disposed within the power-transmission chamber. Finally, we provide, for the photo-acousto-attachment of the machine, a film-advancing mechanism that minimizes the distorting effect in the sound of the discrepancy between the perfora-

tion pitch of the film and tooth pitch of the sprocket.

The novel features that we consider characteristic of our invention are set forth with particularity in the appended claims. The invention itself, however, both as to its organization and its method of operation, together with additional objects and advantages thereof, will best be understood from the following description of a specific embodiment, when read in connection with the accompanying drawings, in which:

Figure 1 is a view, in perspective, of an acousto-cinematographic machine constructed according to our invention,

Fig. 2 is a view, in front elevation, showing the principal elements of the automatic threading device of the machine,

Fig. 3 is a view, in plan, showing the arrangement of the shafts or pins on which the threading guides and loop-formers are mounted and through which they are motivated,

Fig. 4 is a view, in transverse section, of the sound gate of the machine,

Fig. 5 is a view, in transverse section, of the picture gate of the machine,

Fig. 6 is a view, in plan, of the power-transmission chamber of the machine without the cover,

Fig. 7 is a view, in front elevation, of the main drive shaft of the machine,

Fig. 8 is a view, in perspective, of the cover of the power-transmission chamber,

Fig. 9 is an exploded view of the intermittent-movement devices of the apparatus,

Fig. 10 is a schematic view of a large and a small sprocket showing, in detail, the advantage of the large sprocket for photo-acoustic apparatus,

Fig. 11 is a schematic drawing to which reference will be made in explaining the derivation of an expression for the minimum diameter that a sprocket applicable to photo-acoustic work should have,

Fig. 12 is a view, in section, showing the picture and sound optical systems,

Fig. 13 is a view, in section, taken along line XIII—XIII of Fig. 6, and

Fig. 14 is a view, in perspective, showing a take-up reel used with the machine.

The apparatus shown in the drawings comprises a hollow casting 1 provided with a supporting web 3, on one surface 5 of which are mounted a plurality of movable and stationary guides constituting an automatic threading device.

A feeding web 7, having a roll of film 9 wound thereon, is positioned on a spindle 11 that is rotatably supported on a bracket 13 with which the main casting 1 is provided. The free end of the film 9 is inserted in an opening 15 of funnel shape into which the teeth 17 of a rotating sprocket wheel 19 are projected.

The film thus presented to the sprocket wheel 19 is grasped thereby and projected against the wall of a loop-forming guide 21 that is pivotally supported on a pin 23 which projects into the cavity 25 of the casting 1. Acting under the thrust of the sprocket wheel 19, the film further advances between an aperture plate 27 and a shoe plate 29 of a picture gate 31 that are separated from each other for threading purposes, as will be described presently.

Directly below the aperture plate, the film 9 is grasped by a plurality of intermittently moving claws 33 and is projected against the lower wall of a loop-former 35 that is riveted to a

metallic plate which is pivotally supported on a stud 39 that projects through the casting 1.

The lower loop-former 35 engages a metallic strip 41 that is slidably supported in the picture gate 31 and is equipped with a plurality of inclined fingers 48 to coast with the shoe-plate 29 to hold it in open position. When the loop former 35 is pivoted away from the gate 31, as will be hereinafter described, the metallic strip 41 settles, under its own weight, to allow the shoe-plate 29 to assume an active position relative to the film.

The film is restricted partly by the loop-former 35 and partly by a stationary guide 45 mounted on the surface 5 of the hollow casting 1 in proximity to the loop-former, and, as it advances, under the combined action of the sprocket wheel 19 and the intermittent claws 33 and under the restraining influence of these guiding elements, its central line assumes, in their vicinity, the form of a skew curve of comparatively large radius of curvature.

From the lower loop-former 35, the film is projected between the aperture plate 47 and the shoe-straps 49 of a sound gate 51 that is parallel to the picture gate 31 but is horizontally displaced therefrom. The upper ends of the shoe-strap 49 are fastened to a stud 53 that projects from the main casting 1, and the lower ends are fastened to a stud 55 that is mounted on the plate 37 to which the lower loop-former 35 is riveted. As a result, the straps 49 are displaced relative to the aperture plate 47 by the pivoting motion of the loop-former 35 and, when the latter is in its closed position, the former is separated from the aperture plate, leaving a comparatively spacious channel through which the film may pass with facility.

After passing through the gate 51, the film advances in the channel formed between the flanges of an idler 57 and a stationary guide 39, and its end is thrust into the path of the teeth 61 of a second rotating sprocket wheel 63. It is grasped by the sprocket wheel 63 and is directed into the opening formed between a plurality of guides 65 and 67 where it passes over an idler 69, rotatably supported on a resiliently mounted bracket 71, and is thrust into one of a plurality of slots, provided between the edges of a multiplicity of strips 73 which constitute the hub of the take-up reel 75, as will be presently described. The reel 75 is mounted on a spindle 77 that is driven from the prime mover 79 of the apparatus through a belt 81 and, as it rotates, the film 9 is fastened thereto.

The guides 65 and 67, between the reel and the second sprocket wheel 63, are rigidly mounted on a plurality of pins 83 and 85 that project into the cavity 25 of the main casting 1. The pins are rotatably supported in bearings 87 and 89 and are pressed into a web 91 that is cast integral with the main supporting base 1 and into the faces of the base. The guides are, furthermore, pivotally movable relative to each other and, in moving, rotate the pins 83 and 85.

A bell link 93 is rigidly fastened, at its center, to the pin 83 that is rotated with the upper guide 65, while a short stud 95, projecting from one arm 97 of the bell link 93, engages a lever 99 fastened to the lower guide 67 in a slot 101. The remaining arm 103 of the bell link 93 is provided with a second stud 105 to which the movable end of a coil spring 107 that is anchored to the main casting 1 in a stud 109 which projects inwardly therefrom, is fastened.

It is seen that the bell link 93 may be rotated

from either of the guides 65 and 67 and, in rotating, it moves the remaining guide relative to the guide that is moved. Moreover, as the link 93 rotates, the stud 105, to which the spring is fastened, is moved from one side of the link center 83 to the opposite side thereof, thus causing the spring 107 to reverse the action of the coupling force that it exerts between the guides 65 and 67. The guides are thus locked in their closed positions when the movable stud 105, that supports the spring, passes above the pin 83 and are urged to their most divergent position when the stud passes below the pivot.

The spring 107 is fastened near the end of the stud 105 and, near its central section, the stud is engaged by a slotted lever 111. The lever 111 is fastened to the end of the pin 23 that supports the upper loop-former 21 at its remaining end, and, as it is moved by the action of the bell link 93, it rotates the pin 23 to cause the loop-former 21 to move relative to the lower film guide 113 in its proximity.

The pin 85, to which the lower take-up-reel guide 67 is fastened, projects through the rear wall 115 of the main casting 1 and has mounted, on its projecting end, a short toggle link 117 that is coupled to a comparatively long lever 119 by a stud 121 fastened therein. The lever 119 is slotted, at its lower end, and engages a crank link 123 that is pivoted on the pin 39, to which the plate 37, riveted to the lower loop-former 35, is fastened.

The lower loop-former 35 is thus actuated from the take-up-reel guides. A stud 124, projecting from the face 5, prevents the loop-former 35 from being excessively deflected when it is in its open position.

A spring 125, anchored in a pin 127 that projects from the rear wall 115 of the casting 1, engages the pin 129 to couple the crank lever 123 and the long lever 119 and coact with the toggle link 117 to positively hold the links and levers in either of their extreme positions.

The automatic threading system may be manually closed, in preparation for the threading operation, in which case, it assumes the form shown in Fig. 1. It is opened by the action of the winding of the film 9 on the reel 75 and assumes the form shown in Fig. 2. It is to be noted that, when the threading arrangement once assumes a terminal position, a positive force of definite magnitude and duration is required to cause it to change its position.

The apparatus is driven, through a series of worms 131, 133 and 135 and worm gear wheels 137, 139 and 141, from the shaft 143 of the prime mover 79 that projects lengthwise through the cavity and is rotatably supported in bearings 145 pressed into the ends thereof. The sprocket wheel 63 that pulls the film through the sound gate 51, and the cam disc 147 that actuates the intermittent movement device and the shutter 149 are driven through the worms 131 and 135 and gear wheels 137 and 141, nearest the two ends of the shaft 143, while the sprocket wheel 19, that delivers the film from the feeding-reel 7, is driven through the central worm 133 and the gear wheel 139.

A conical plate 151 is centrally supported on the intermittent shaft 153 and is rotatable therewith. It rotates in a cavity 155 disposed below the remaining surface of the power-transmission chamber 25 and projects the lubricant that flows into the cavity 155 against an angular plate 157 that is fastened to the cover 159 of the trans-

mission chamber and is inclined thereto. The fluid dripping from the plate lubricates the bearings and flows, under the action of gravity, into the cavity 155 where it is again discharged by the conical plate 151. The lubricant is thus circulated through the bearings of the moving mechanism.

The intermittent-movement device comprises a plate 159 whereon a second slotted plate 161 is mounted to form a recess 163 therewith. A lever 165, guided by a slotted stud 167, rotatably mounted in the first plate 159, is disposed within the recess 163 in such manner that it is capable of sliding and pivoting therein.

The lever 165 is equipped with a slot 169 that engages a cam pin 171, projecting from the cam disc 147, and with a pin 173 that engages a cam slot 175, milled in the surface of the cam disc. It is actuated by the cams and, in moving, it actuates the claws 33 integral with an arm 177 that is rigidly fastened to its upper end. The cam 171 and slot 169 coact to provide the horizontal movement of the claws 33, and the cam slot 175 and pin 173 coact to provide the vertical movement.

A cavity 179 is provided in the surface 5 of the casting 1 wherein the cam disc 147 rotates. The recess 163 is equipped with a slotted cover 181 into which the cam pin 171 projects and through which the pin 173 protrudes. The unit, thus formed by the three plates 159, 161 and 181 and the lever 165 and the arm 177, is fastened to the face 5 of the casting 1 vis-a-vis with the disc 147 and, since the surfaces facing each other are accurately machined, the fluid lubricating the intermittent movement device is not exuded.

By reason of the fact that films ordinarily change in length, to varying degrees, when subjected to developing, fixing and ageing processes, it is not possible to exactly predetermine their perforation pitch. Consequently, a discrepancy between the sprocket-tooth pitch and the film-perforation pitch generally exists, and the film cannot be advanced by an ordinary sprocket wheel at the constant synchronous speed that is necessitated for satisfactory photo-acoustic reproduction. One solution of the problem thus arising, which is described in a copending application of C. R. Hanna and E. H. Greibach, Serial No. 406,847, filed November 13, 1929, and assigned to Westinghouse Electric and Manufacturing Company, includes the use of a flexibly-driven pulling sprocket wheel and a flywheel.

We have found that, as the diameter of the sprocket wheel that is employed to advance the film through the sound gate is increased, the angle through which it moves, before a film that is being engaged by a tooth settles from the top of the tooth to the base, is increased. In Fig. 10, the phenomenon is shown in detail and it is seen that the tooth 183 of the small sprocket wheel 185 is displaced from the film a considerably greater distance than the tooth 61 of the sprocket wheel 63.

The sprocket wheel has a pitch that is equivalent to the largest pitch that the perforations of the film can possibly have. It is, furthermore, so disposed in the machine that the film leaving it is under tension. Such a sprocket wheel functions as a hold-back means, and its entering tooth is the only tooth that actively engages the film.

The discrepancy that exists in the distance between any two successive perforations and the teeth by which they are engaged is equalized by a longitudinal movement of the film, relative to

the sprocket wheel. The equalization takes place in the time interval occupied by the film in settling from the top of an entering tooth to its base and is, consequently, less abrupt for a large sprocket wheel than it is for a small sprocket wheel.

The explanation has been applied here to a holdback sprocket wheel and the sprocket wheel used in the machine is of this type. However, the theory applies to a feeding sprocket wheel in which case the tooth pitch is made equivalent to the smallest film-perforation pitch that is possible in practice.

A mathematical expression for the minimum diameter of the sprocket wheel required to yield the maximum period of adjustment may be derived by referring to Fig. 11, wherein:

r is the radius of the sprocket wheel,

p is the distance between two perforations of the film,

h is the height of a sprocket-wheel tooth.

It is seen that

$$(1) \quad (r+h)^2 = r^2 + p^2$$

therefore

$$(2) \quad 2rh + h^2 = p^2$$

$$(3) \quad 2r = D = \frac{p^2 - h^2}{h}$$

where D is the diameter.

Hence the condition may be expressed by the inequality

$$(4) \quad D \text{ is greater than } \frac{p^2 - h^2}{h}$$

and, since p is ordinarily large, as compared with h , the inequality (4) may be interpreted qualitatively as a requirement that D , the diameter, shall be large relative to the perforation pitch.

The irregularities in the velocity of the film which are introduced by the reel are prevented from getting into the sound take-off by the resiliently mounted idler 69. Any further irregularities which may be introduced by the sprocket wheel, by reason of imperfect manufacture, are ironed out by the idler 57 between the sprocket wheel 63 and the gate 51.

It is to be noted that the position of the resiliently pivoted bracket 71 varies over a considerable angle as the tension in the film is varied. Moreover, as is clearly evident, the bracket occupies an extreme position against the upper-take-up-reel guide 65 if the film is not engaged in the reel and hence is not tensioned.

By reason of the variation in the position of the idler 69, relative to its neighboring guides 65 and 67, it may be utilized as the operating element of a device for stopping the machine if the guides are opened, by accident, before the film becomes fastened to the reel.

Such a stopping device is clearly within the scope of our invention and, since the proper disposition of insulating blocks and connectors for a relay can be accomplished by one skilled in the art without the exercise of invention, we have not unnecessarily complicated the specification by adding a detailed description of the feature.

The sound track and the picture rectangle are both illuminated from a single source 187 situated in a housing 189 behind the main casting 70. The beam illuminating the picture aperture is projected directly from the lamp 187 through an opening 191 situated in the lower section of the main casting 1. The rays from the lamp are converged by a lens 193 situated within the opening 191 and are reflected substantially at right

angles by a mirror 195 to illuminate a picture in the aperture. The picture is, in turn, projected upon a screen by a projection lens 197.

The sound aperture is illuminated by the indirect light reflected from a curved mirror 199. The rays are further converged by a lens 201 situated in a second opening 203, parallel to the first, and then are bent at right angles by a second reflector 205 to illuminate the sound track on the film positioned adjacent to the aperture. 10

The illuminated sound-track is magnified by a microscope objective 217 and focused on a slit (not shown) behind which a photo-cell (not shown) is situated.

The take-up reel 75 comprises two flanged plates 209 which are stiffened by a plurality of indentations 211 pressed therein and are separated by a plurality of curved metallic strips 73 that are riveted to them to constitute the hub of the reel. The strips 73 overlap each other, and an opening is provided between them wherein the end of the film may be thrust. They are provided with teeth 213, on one side, whereby the film is engaged in its perforations when it has once entered a slit. 25

The reel is rotated in such direction that the overlapping ends of the strips advance against the film. The film is thus bent back and bodily displaced perpendicular to itself when its end is once engaged in a slot in the hub. It is thus caused to coact with the upper take-up-reel guide 65 to actuate the moving parts of the threading arrangement. 30

Although we have shown and described certain specific embodiments of our invention, we are fully aware that many modifications thereof are possible. Our invention, therefore, is not to be restricted except insofar as is necessitated by the prior art and by the spirit of the appended claims. 40

We claim as our invention:

1. In acousto-cinematographic apparatus, a picture gate, a sound gate, means for advancing a film from a feed reel to said picture gate, means for advancing said film through said picture gate, and means for advancing said film from said sound gate to a take-up reel, in combination with guiding means disposed between said film-advancing means and said gates, between said gates and between said reels and said film-advancing means, the guiding means between said take-up reel and said film-advancing means projecting the film onto said take-up reel at a point such that the portion of the film adjacent the take-up reel is moved transversely to itself immediately on engagement of the film with the take-up reel, and means to be actuated by the winding of the portion of the film which is moved transversely when the film is engaged with said take-up reel, mechanically coupled to said guiding means for moving all of said guiding means transverse to said film. 50

2. In film-handling apparatus, an automatic threading device comprising means for advancing a film from a feed-reel to a gate, means for advancing said film through said gate, means for delivering said film to a take-up reel, means for forming a loop-reservoir between said first film-advancing means and said gate, means for forming a loop-reservoir between said gate and said film-delivering means, means for applying a pressure on said film in said gate, and guiding means disposed between said film-delivering means and said take-up reel, the last said guiding means and said take-up reel cooperating to move 75

the portion of the film adjacent the take-up reel in a direction transverse to itself immediately on engagement of the film with the take-up reel, said loop-reservoir-forming means being normally in a position such as to restrict the formation of a loop and to guide said film and said pressure-applying means being normally in a position such that the pressure is relieved and said film is permitted to pass through said gates with facility and said guiding means including an arm, to be actuated by the portion of the film, which moves transversely to itself while in said transverse motion, and means for mechanically coupling said arm to said loop-reservoir-forming means and said pressure-applying means, for actuating said loop-forming means to permit the formation of loops and for actuating said pressure-applying means to apply pressure, when said arm is so actuated.

3. In a film handling apparatus, an automatic threading system including a plurality of fixed guides through which a film is to be advanced, a plurality of movable guides normally disposed adjacent to said fixed guides to form channels with said fixed guides for restraining the movement of the film along a predetermined path, a take-up reel on which said film is to be wound after it is advanced through said channels, a plurality of arms normally disposed adjacent to each other and to said reel and forming a guiding channel therebetween to so guide said film to said reel that the film moves transversely to itself as soon as it engages the take-up reel, means to be actuated by the film as it moves transversely to itself, when it engages said take-up reel for separating said arms and mechanisms interconnecting said arms and said movable guides for moving said movable guides away from said fixed guides when said arms are separated, thereby permitting loops to form in the film between said movable guides and said fixed guides.

4. In acousto-cinematographic apparatus, an enclosure having a picture gate and a sound gate, mounted on one surface thereof, the transverse center line of said gates being at substantially equal distances from a parallel edge of said surface and the longitudinal center lines of said gates lying in different vertical planes parallel to said surface.

5. In acousto-cinematographic apparatus a supporting wall having a plurality of film gates so mounted on one surface that when a film is advanced through said apparatus it moves in one direction through one of said gates and in the opposite direction through another of said gates, said gates being displaced to each other in a direction transverse to said wall so that their longitudinal center lines lie in different planes parallel to said wall, a source of illumination disposed behind the other surface of said wall and means for projecting radiations from said source on the surfaces of said film in said gates to illuminate said surfaces.

6. A film-moving and reeling apparatus adapted for acousto-cinematographic apparatus comprising means for moving a film, a guide channel for said film having separable walls adapted in one relative position to provide a relatively narrow channel for the film in its desired operative position in an optical projection system and in another relative position to provide a substantially wider channel into which said film can be readily threaded, a take-up reel, means for guiding the film to the take-up reel in such manner that the portion of the film which is immediately

adjacent to the take-up reel is moved transverse to itself when the film engages the take-up reel, and means to be actuated by the last said portion of the film when it is moved transversely to cause said separable walls to move from their last-named relative position to their first-named relative position immediately on the engagement of the film and the take-up reel.

7. Film handling apparatus comprising means for storing a film, means for advancing said film from said storing means, a plurality of fixed guides over which said film is to be projected, a plurality of movable guides normally disposed adjacent to said fixed guides and forming channels therewith to restrict the movement of the film along a particular path, a take-up reel to which said film is to be advanced after it passes through said channels, a plurality of plates and means for normally so positioning said plates adjacent to each other and the terminals thereof adjacent to said take-up reel that a guiding channel for said film as it is projected onto said take-up reel is provided that is of such character that the film moves transversely to itself as it engages the take-up reel, means to be actuated by one of said plates, when it is moved in a direction perpendicular to the other plate by the film in its transverse motion between the plates, as it is engaged by said take-up reel and advanced thereby, for actuating said positioning means to separate said plates and to permit the film to freely advance to said take-up reel and mechanisms coupling said plates to said movable guides whereby said movable guides are separated from the corresponding fixed guides by the separation of said plates and loops are permitted to form between said movable guides and said fixed guides.

8. Film handling apparatus comprising means for storing a film means for intermittently advancing said film from said storing means, a fixed guide over which said film is to pass to said intermittent-advancing means from said storing means, a movable guide normally disposed adjacent to said fixed guide and forming a channel therewith to restrict the movement of the film along a predetermined path, another fixed guide over which said film is to pass after it has been advanced by said intermittent-advancing means, another movable guide disposed adjacent to said last-named fixed guide and forming a channel therewith to restrain the movement of said film along a predetermined path, a take-up reel on which said film is to be wound after it has been advanced by said intermittent-advancing means, a plurality of plates and means for normally positioning said plates adjacent to each other to form a channel therebetween and adjacent to said take-up reel whereby said film is guided by said plates to said take-up reel, means to be actuated by said film as it is wound on said take-up reel for separating said plates to permit the free movement of the film, mechanisms coupling one of said plates to said first-named movable guide whereby when said plate is moved said first-named movable guide is separated from said first-named fixed guide and a loop is permitted to form in the film therebetween and mechanisms coupling another of said plates to said last-named movable guide, whereby when said last-named plate is moved said last-named movable guide is separated from said last-named fixed guide and a loop is permitted to form on the film therebetween.

9. In acousto-cinematographic apparatus of 75

the type incorporating a supporting wall having a plurality of film gates so mounted on one surface that when a film is advanced through said apparatus it moves in one direction through one of said gates and in the opposite direction through another of said gates, said gates being displaced to each other in a direction trans-

verse to said wall so that their longitudinal center lines lie in different planes parallel to said wall, an automatic threading system including a skew channel disposed between said guides to guide the film from one gate to the other.

FRANK CONRAD.

CHRISTIAN AALBORG.