

W. F. RICHARDS.
CAR BUFFER.

No. 524,217.

Patented Aug. 7, 1894.

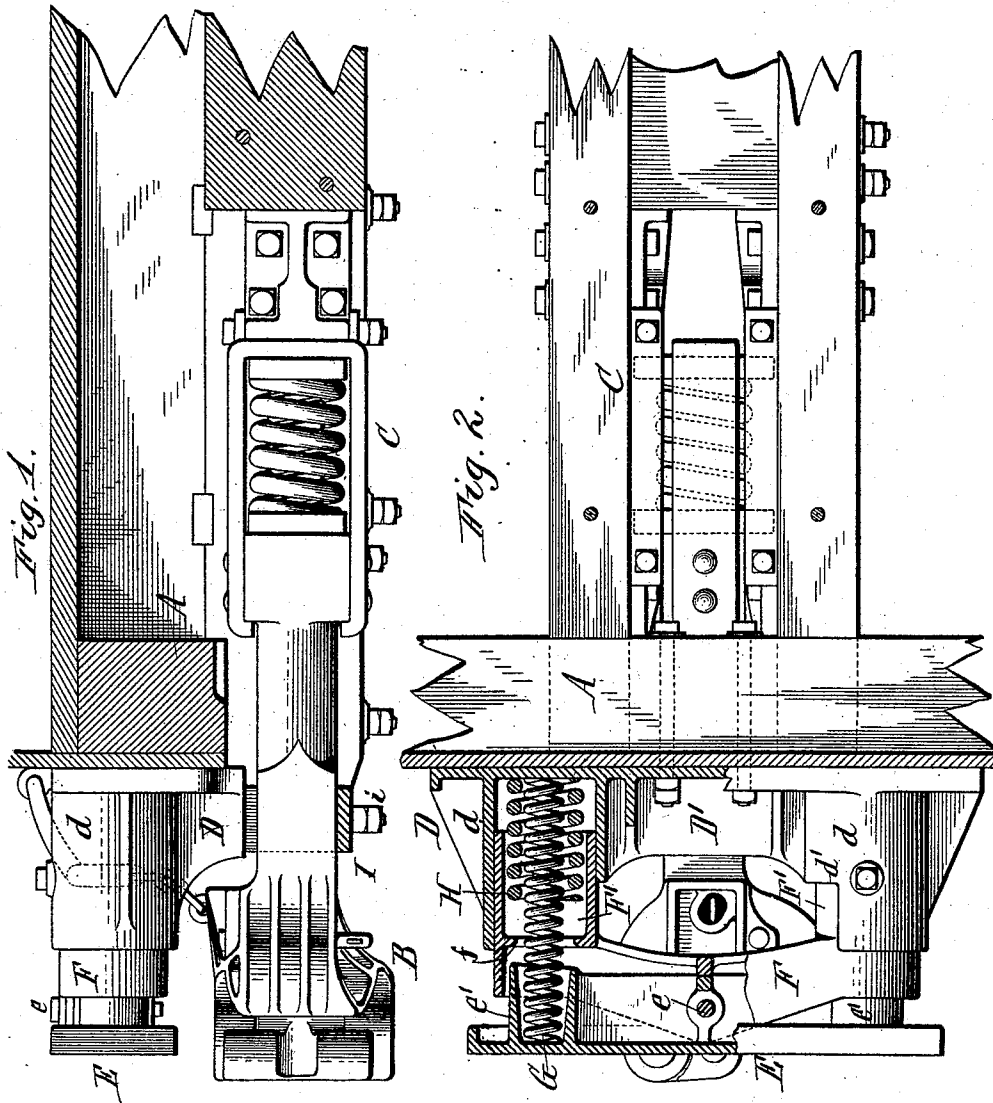

Witnesses:
Emil Neuhart.
Chas. F. Burkhardt

W. F. Richards Inventor.
By Wilhelm Morner
Attorneys.

W. F. RICHARDS.
CAR BUFFER.

No. 524,217.

Patented Aug. 7, 1894.

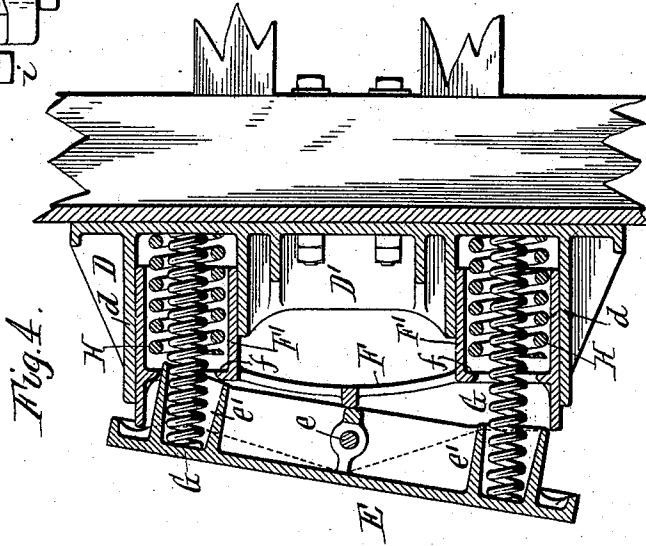
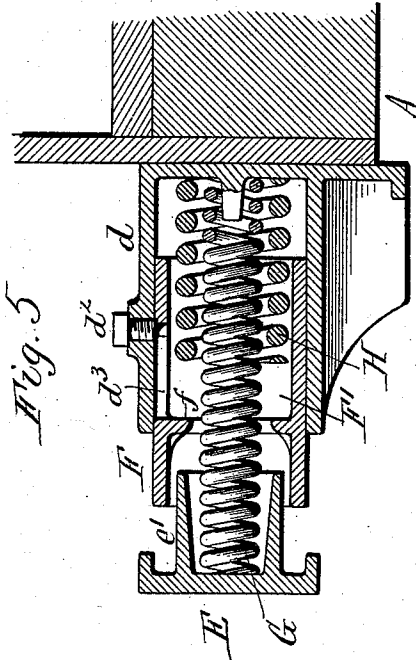
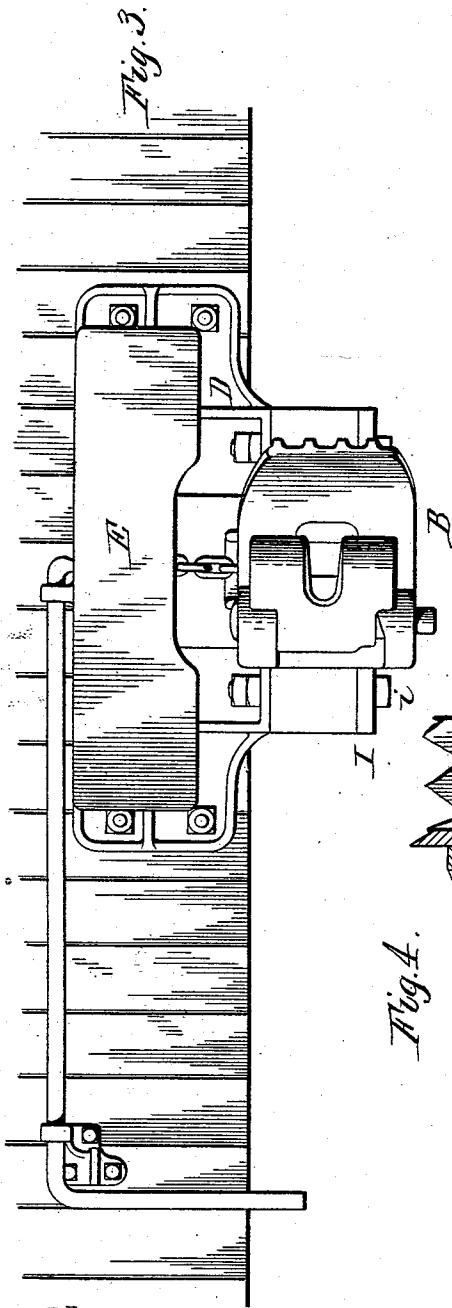

Witnesses:
Emil Neuhart
Chas. F. Burkhart.

W. F. Richards. Inventor.
By Wilhelm H. Pomeroy.
Attorneys.

W. F. RICHARDS.
CAR BUFFER.

No. 524,217.

Patented Aug. 7, 1894.

Fig. 6. F.

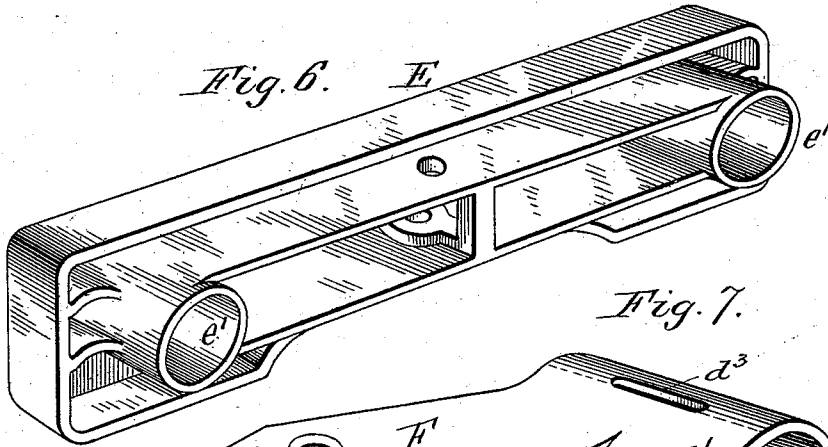

Fig. 7.

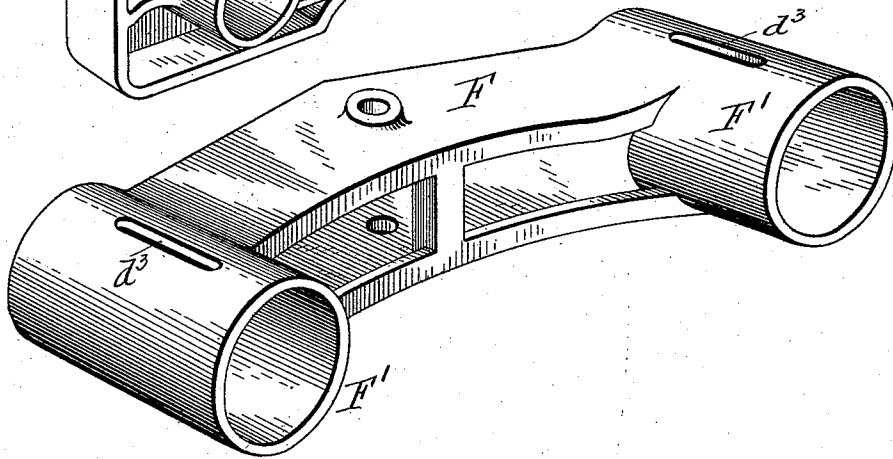
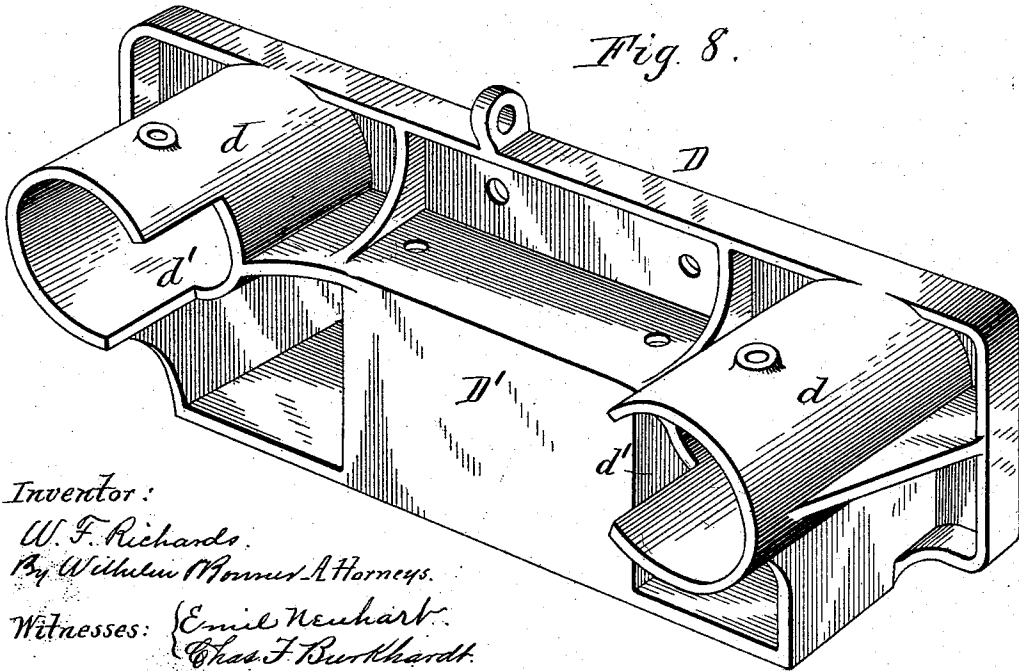

Fig. 8.



Inventor:

W. F. Richards.

By Wilhelm Morner, Attorneys.

Witnesses:

Emil Neuhart.
Chas. F. Burkhardt.

UNITED STATES PATENT OFFICE.

WILLARD F. RICHARDS, OF BUFFALO, ASSIGNOR TO THE GOULD COUPLER COMPANY, OF NEW YORK, N. Y.

CAR-BUFFER.

SPECIFICATION forming part of Letters Patent No. 524,217, dated August 7, 1894.

Application filed March 27, 1894. Serial No. 505,240. (No model.)

To all whom it may concern:

Be it known that I, WILLARD F. RICHARDS, a citizen of the United States, residing at the city of Buffalo, in the county of Erie and State of New York, have invented a new and useful Improvement in Car-Buffers, of which the following is a specification.

This invention relates to a car buffer which is designed more particularly for freight and cattle cars, although it is also applicable to other cars.

My invention has for its object to construct an effective buffer which is readily applied to a car and which does not require the end sill or other timbers of the car frame to be slotted or recessed, thereby avoiding weakening of the frame.

In the accompanying drawings consisting of three sheets:—Figure 1 is a fragmentary sectional elevation of a freight car, provided with my improved buffer. Fig. 2 is a top plan view of the buffer, partly in section. Fig. 3 is an end view thereof. Fig. 4 is a horizontal section of the buffer, showing the position thereof, when the cars round a curve. Fig. 5 is a vertical longitudinal section in line 5—5, Fig. 2, on an enlarged scale. Fig. 6 is a detached perspective view of the oscillating buffer, on an enlarged scale. Fig. 7 is a similar view of the yoke or follower which carries the buffer. Fig. 8 is a similar view of the stationary bracket or base plate of the buffer.

Like letters of reference refer to like parts in the several figures.

A is the end sill of the car frame, B the draw-head and C the draft gear, which parts may be of any ordinary construction.

D is a transverse base plate or bracket secured to the end of the car body above the draw-head and having horizontal sockets d , which project forwardly from the base plate and are connected by a reinforcing rib D' .

E is the buffer or transverse buffer plate, and F is a horizontal yoke or frame which carries the buffer plate and which is capable of moving upon the base plate toward and from the end of the car. This yoke is provided at its ends with tubular followers or sleeves F' , which slide in the sockets d of the base plate. These sockets are provided on their inner sides with longitudinal slots d' for the pas-

sage of the yoke. The outward movement of the followers is limited by radial pins or bolts d^2 secured to the sockets d and projecting inwardly through longitudinal slots d^3 formed in the followers, as shown in Fig. 5. The buffer plate is pivoted centrally to the yoke F, by a vertical pin e , whereby the plate is permitted to swing at an angle to the end of the car in rounding curves.

G G represent light buffer springs which tend to retain the oscillating buffer in its normal position parallel with the end of the car, and which resist any ordinary shocks received by the buffer. These springs pass through the tubular followers of the yoke F, and bear at their rear ends against the base plate D, and at their front ends against the rear side of the buffer plate, on opposite sides of the pivot of the latter. The buffer plate is preferably formed on its rear side with rearwardly flaring sockets e' , in which the front portions of the light buffer springs are confined.

H H represent heavy buffer springs which supplement the light buffer springs and which are adapted to come into action when the buffer receives a heavy shock which overcomes the resistance of the light springs. These heavy buffer springs are arranged within the tubular followers of the yoke F, around the light springs, and each of such heavy springs abuts at its rear end against the base plate D, while its front end is adapted to bear against an inwardly projecting flange or shoulder f , formed in the front portion of the adjacent tubular follower, when the buffer plate is forced inward beyond its ordinary position by a violent shock. For this purpose the heavy springs are so short that the internal flanges of the followers do not reach the front ends of such springs, under ordinary circumstances.

The light buffer springs are preferably so long that when the buffer is in normal contact with the buffer of an opposing car, the springs are slightly compressed, but not to such an extent as to interfere with the easy coupling and uncoupling of the cars. These light springs cushion the buffer and resist any ordinary shocks received by the same. The inward movement of the buffer and its

carrying yoke produced by ordinary shocks is not sufficient to cause the flanges *f* of the followers to come in contact with the front ends of the heavy buffer springs, but in case
 5 the buffer receives a severe shock which overpowers the light springs, the flanges strike the front ends of the heavy buffer springs and compress the same, thereby easing the shock and also protecting the draft
 10 gear from injury.

The light springs while cushioning the buffer against ordinary blows permit the buffer to oscillate in rounding a curve and right the same when the car again passes upon a
 15 straight section of track.

The parts of my improved car buffer are all arranged on the outer or front side of the end sill and the formation of slots or recesses required by the use of ordinary car buffers, is
 20 therefore obviated, thus preserving the strength of the end sill.

The parts of the buffer may all be cast at a comparatively small cost, and the buffer forms an attachment, complete in itself,
 25 which is readily applied to an ordinary car.

The vertical bolts *i* which secure the carrier *I* of the draw head shank to the frame timbers preferably pass through the bottom flange of the base plate *D*, as shown in Figs.
 30 1 and 3.

I claim as my invention—

1. In a car buffer, the combination with the base plate or bracket secured to the end of the car and having a forwardly projecting socket,
 35 of a follower carrying a buffer and guided in said socket, and a light spring and a heavy spring fitted in said socket, said light spring holding the follower and buffer out normally and the heavy spring being adapted to bear
 40 against the follower when the light spring has been partially compressed, substantially as set forth.

2. The combination with the end sill of a car, of a base plate or bracket secured to the outer side of the end sill, a transverse yoke or
 45 frame guided on said base plate or bracket and capable of moving toward and from the latter, a buffer plate mounted on said yoke, and buffer springs which resist the inward movement of said yoke, substantially as set forth. 50

3. The combination with the end sill of a car, of a base plate or bracket secured to the outer side of the end sill, a transverse yoke or
 55 frame guided on said base plate and capable of moving toward and from the latter, an oscillatory buffer plate pivoted to said yoke, heavy buffer springs interposed between said yoke and the base plate and light springs interposed between the oscillatory buffer plate and the base plate, substantially as set forth. 60

4. In a car buffer, the combination with the base plate having sockets, of a yoke having followers guided in said sockets, a buffer plate mounted on said yoke, light buffer springs interposed between said base plate and the buffer
 55 plate and heavy buffer springs abutting against said base plate and adapted to be compressed by said followers, substantially as set forth.

5. In a car buffer, the combination with the
 70 base plate having sockets, of a yoke having followers guided in said sockets, and provided with a shoulder or flange, light buffer springs interposed between the base plate and the buffer plate and heavy buffer springs arranged
 75 in the sockets of the base plate between the latter and the shoulders or flanges of the followers, substantially as set forth.

Witness my hand this 14th day of March, 1894.

WILLARD F. RICHARDS.

Witnesses:

JNO. J. BONNER,
 ELLA R. DEAN.