



- (51) International Patent Classification:
G06F 13/16 (2006.01) G06F 13/40 (2006.01)
- (21) International Application Number:
PCT/US2017/032019
- (22) International Filing Date:
10 May 2017 (10.05.2017)
- (25) Filing Language: English
- (26) Publication Language: English
- (30) Priority Data:
15/159,728 19 May 2016 (19.05.2016) US
- (71) Applicant: MICRON TECHNOLOGY, INC. [US/US];
8000 South Federal Way, Boise, Idaho 83716 (US).
- (72) Inventors: HOLLIS, Timothy M.; 2654 S. Velvet Falls
Way, Meridian, Idaho 83642 (US). VO, Huy T.; 6221 S.
Snapdragon Place, Boise, Idaho 83716 (US). KHATRI,
Dirgha; 6652 S. Liveoak Place, Boise, Idaho 83716 (US).

- (74) Agent: ENG, Kimton et al.; Dorsey & Whitney LLP, 701
5th Ave, Suite 6100, Seattle, Washington 98104 (US).
- (81) Designated States (unless otherwise indicated, for every
kind of national protection available): AE, AG, AL, AM,
AO, AT, AU, AZ, BA, BB, BG, BH, BN, BR, BW, BY, BZ,
CA, CH, CL, CN, CO, CR, CU, CZ, DE, DJ, DK, DM, DO,
DZ, EC, EE, EG, ES, FI, GB, GD, GE, GH, GM, GT, HN,
HR, HU, ID, IL, IN, IR, IS, JP, KE, KG, KH, KN, KP, KR,
KW, KZ, LA, LC, LK, LR, LS, LU, LY, MA, MD, ME, MG,
MK, MN, MW, MX, MY, MZ, NA, NG, NI, NO, NZ, OM,
PA, PE, PG, PH, PL, PT, QA, RO, RS, RU, RW, SA, SC,
SD, SE, SG, SK, SL, SM, ST, SV, SY, TH, TJ, TM, TN, TR,
TT, TZ, UA, UG, US, UZ, VC, VN, ZA, ZM, ZW.
- (84) Designated States (unless otherwise indicated, for every
kind of regional protection available): ARIPO (BW, GH,
GM, KE, LR, LS, MW, MZ, NA, RW, SD, SL, ST, SZ, TZ,
UG, ZM, ZW), Eurasian (AM, AZ, BY, KG, KZ, RU, TJ,
TM), European (AL, AT, BE, BG, CH, CY, CZ, DE, DK,
EE, ES, FI, FR, GB, GR, HR, HU, IE, IS, IT, LT, LU, LV,
MC, MK, MT, NL, NO, PL, PT, RO, RS, SE, SI, SK, SM,

(54) Title: APPARATUSES AND METHODS FOR PERFORMING INTRA-MODULE DATABUS INVERSION OPERATIONS

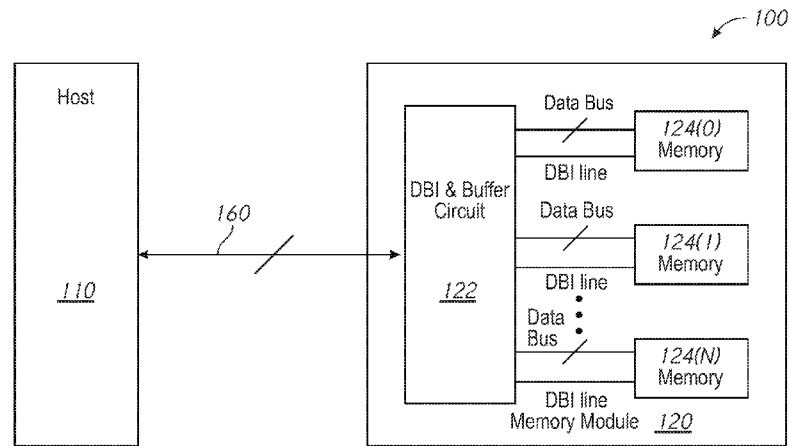

FIG. 1

(57) Abstract: Apparatuses, memory modules, and methods for performing intra-module data bus inversion operations are described. An example apparatus include a memory module comprising a data bus inversion (DBI) and buffer circuit and a plurality of memories. The DBI and buffer circuit configured to encode a block of data received by the memory module and to provide DBI data and a corresponding DBI bit to a respective memory of the plurality of memories.



TR), OAPI (BF, BJ, CF, CG, CI, CM, GA, GN, GQ, GW,
KM, ML, MR, NE, SN, TD, TG).

Published:

— *with international search report (Art. 21(3))*

(88) Date of publication of the international search report:

26 July 2018 (26.07.2018)

A. CLASSIFICATION OF SUBJECT MATTER**G06F 13/16(2006.01)i, G06F 13/40(2006.01)i**

According to International Patent Classification (IPC) or to both national classification and IPC

B. FIELDS SEARCHED

Minimum documentation searched (classification system followed by classification symbols)

G06F 13/16; G11C 7/10; H03M 7/00; H01L 27/108; G06F 13/42; G11C 11/4096; G06F 11/16; G06F 13/40

Documentation searched other than minimum documentation to the extent that such documents are included in the fields searched

Korean utility models and applications for utility models

Japanese utility models and applications for utility models

Electronic data base consulted during the international search (name of data base and, where practicable, search terms used)

eKOMPASS(KIPO internal) & Keywords: data, bus, inversion, memory, encode, decode, bit, store, and similar terms.

C. DOCUMENTS CONSIDERED TO BE RELEVANT

Category*	Citation of document, with indication, where appropriate, of the relevant passages	Relevant to claim No.
Y	US 2012-0195131 A1 (GEORGE PAX) 02 August 2012 See paragraphs [0016], [0021], [0026], [0032], [0041]-[0044], [0048]-[0050], and [0066]; claims 1, 7, 13, and 17; and figure 5.	1-26
Y	US 2009-0179782 A1 (TIMOTHY M. HOLLIS) 16 July 2009 See paragraphs [0010], [0024], and [0037]; and figure 4B.	1-26
A	US 2014-0289460 A1 (GSI TECHNOLOGY, INC.) 25 September 2014 See paragraphs [0038] and [0044]; and figure 7.	1-26
A	US 2014-0053040 A1 (MICRON TECHNOLOGY INC.) 20 February 2014 See paragraphs [0015] and [0030]; and figure 5.	1-26
A	WO 2014-151637 A1 (QUALCOMM INCORPORATED) 25 September 2014 See paragraphs [0007] and [0024]; and figure 5A.	1-26

 Further documents are listed in the continuation of Box C. See patent family annex.

* Special categories of cited documents:

"A" document defining the general state of the art which is not considered to be of particular relevance

"E" earlier application or patent but published on or after the international filing date

"L" document which may throw doubts on priority claim(s) or which is cited to establish the publication date of another citation or other special reason (as specified)

"O" document referring to an oral disclosure, use, exhibition or other means

"P" document published prior to the international filing date but later than the priority date claimed

"T" later document published after the international filing date or priority date and not in conflict with the application but cited to understand the principle or theory underlying the invention

"X" document of particular relevance; the claimed invention cannot be considered novel or cannot be considered to involve an inventive step when the document is taken alone

"Y" document of particular relevance; the claimed invention cannot be considered to involve an inventive step when the document is combined with one or more other such documents, such combination being obvious to a person skilled in the art

"&" document member of the same patent family

Date of the actual completion of the international search

20 July 2017 (20.07.2017)

Date of mailing of the international search report

24 July 2017 (24.07.2017)

Name and mailing address of the ISA/KR

International Application Division

Korean Intellectual Property Office

189 Cheongsa-ro, Seo-gu, Daejeon, 35208, Republic of Korea

Facsimile No. +82-42-481-8578

Authorized officer

Lee, Eun Kyu

Telephone No. +82-42-481-3580



INTERNATIONAL SEARCH REPORT

Information on patent family members

International application No.

PCT/US2017/032019

Patent document cited in search report	Publication date	Patent family member(s)	Publication date
US 2012-0195131 A1	02/08/2012	US 2009-141564 A1 US 2011-179221 A1 US 2013-132689 A1 US 7925844 B2 US 8156291 B2 US 8356146 B2 US 8688930 B2	04/06/2009 21/07/2011 23/05/2013 12/04/2011 10/04/2012 15/01/2013 01/04/2014
US 2009-0179782 A1	16/07/2009	EP 2212800 A2 US 2010-0214138 A1 US 7501963 B1 US 7701368 B2 US 8018358 B2 WO 2009-051991 A2 WO 2009-051991 A3	04/08/2010 26/08/2010 10/03/2009 20/04/2010 13/09/2011 23/04/2009 02/07/2009
US 2014-0289460 A1	25/09/2014	TW 201506924 A US 2016-293231 A1 US 9384822 B2 WO 2014-146012 A2 WO 2014-146012 A3	16/02/2015 06/10/2016 05/07/2016 18/09/2014 31/12/2014
US 2014-0053040 A1	20/02/2014	US 2010-042889 A1 US 2012-144276 A1 US 8127204 B2 US 8539312 B2 US 8826101 B2	18/02/2010 07/06/2012 28/02/2012 17/09/2013 02/09/2014
WO 2014-151637 A1	25/09/2014	CN 105074681 A EP 2972918 A1 JP 2016-516244 A JP 5911663 B1 KR 10-1587535 B1 KR 10-2015-0132359 A TW 201502791 A TW I519959 B US 2014-0281328 A1 US 9177623 B2	18/11/2015 20/01/2016 02/06/2016 08/04/2016 21/01/2016 25/11/2015 16/01/2015 01/02/2016 18/09/2014 03/11/2015