

# United States Patent

[11] 3,599,445

[72] Inventor **Achim Kehrberger**  
**Nellingen, Germany**  
 [21] Appl. No. **13,080**  
 [22] Filed **Feb. 20, 1970**  
 [45] Patented **Aug. 17, 1971**  
 [73] Assignee **Delmag-Maschinenfabrik Reinhold**  
**Dornfeld**  
**Esslingen, Germany**  
 [32] Priority **Feb. 28, 1969**  
 [33] **Germany**  
 [31] **P 19 10 360.7**

[56] **References Cited**  
**UNITED STATES PATENTS**  
 2,859,939 11/1958 Petrell..... 64/23.5  
 3,128,614 4/1964 Auer..... 64/23.5

*Primary Examiner*—Edward G. Favors  
*Attorney*—Nolte and Nolte

[54] **COUPLING ARRANGEMENTS FOR DRILL RODS OF EARTH-DRILLING TOOLS**  
 7 Claims, 3 Drawing Figs.

[52] U.S. Cl..... 64/23.5  
 [51] Int. Cl..... F16d 3/06  
 [50] Field of Search..... 64/23.5,  
 23.6

**ABSTRACT:** A coupling member for transmitting rotational displacement to a drill rod is disclosed. The drill rod, which has one or more rib members projecting from its periphery, passes through a bore in the coupling member. One or more expendable bearing strip members are detachably mounted on the coupling member and project into the bore to cooperate with the respective rib members to transmit rotational displacement to the drill rod. Preferably, each of the expendable bearing strip members comprises a plurality of parts and is provided with a built-up weld in that region of the respective bearing strip member which is adjacent to a cooperating projecting rib member.

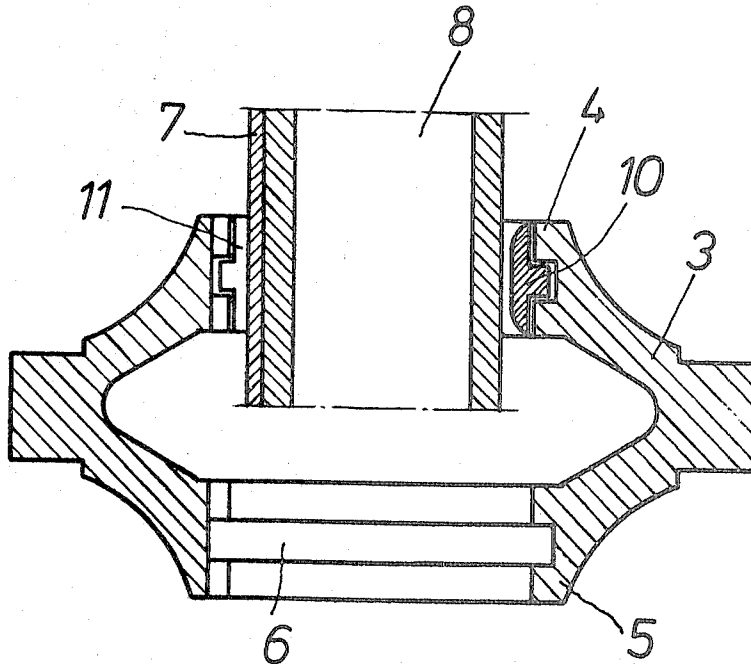

Fig.1

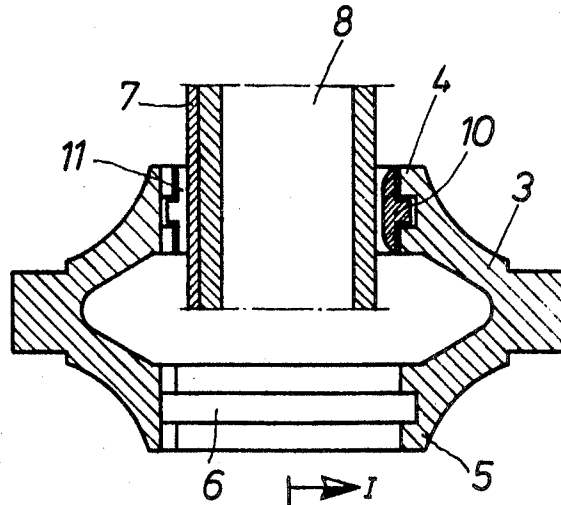
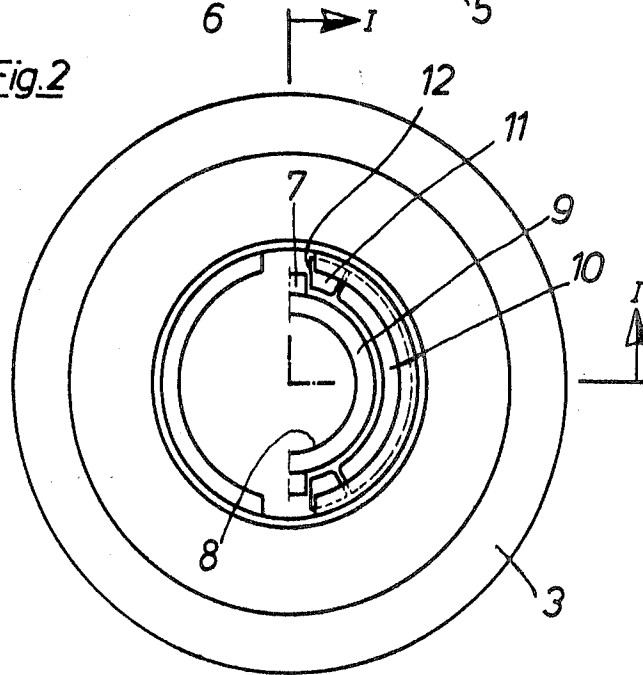
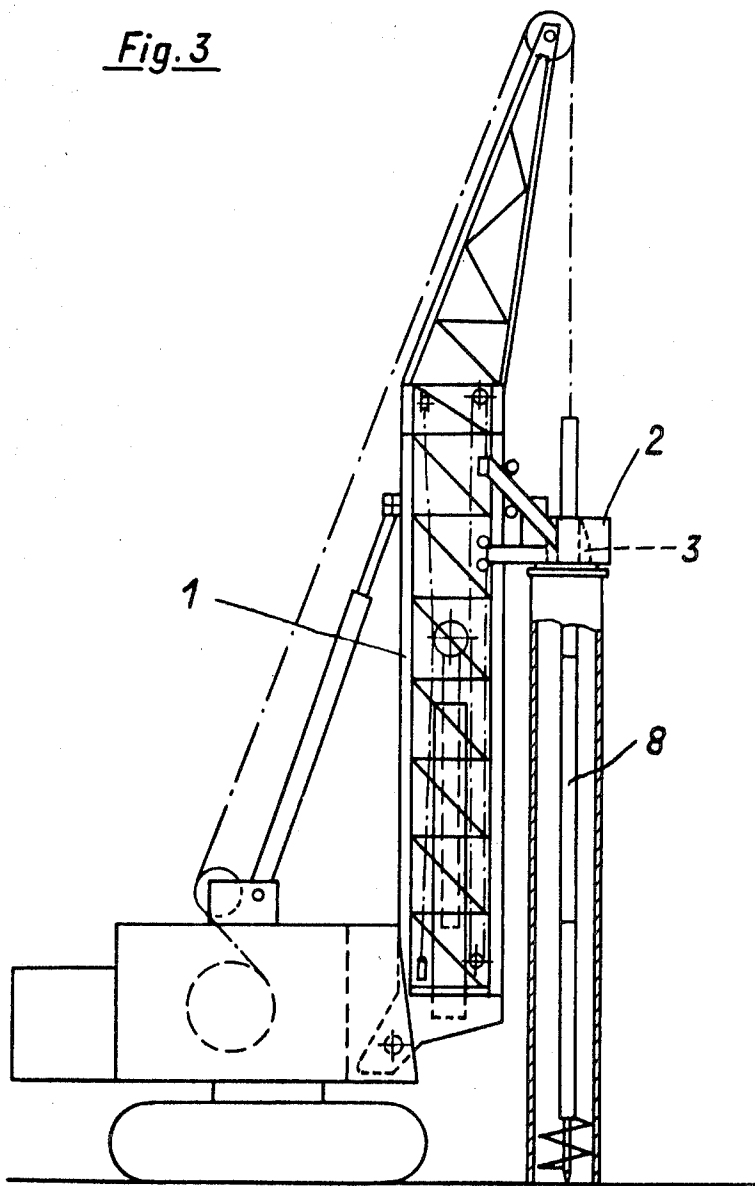

Fig.2



INVENTOR  
ACHIM KEHRBERGER  
BY *Wolke & Wolke*  
ATTORNEYS

Fig. 3



INVENTOR

ACHIM KEHRBERGER

BY

*Wolter Wolter*  
ATTORNEYS

## COUPLING ARRANGEMENTS FOR DRILL RODS OF EARTH-DRILLING TOOLS

### BACKGROUND OF THE INVENTION

The present invention relates to a coupling arrangement for coupling the drill rod of an earth-drilling tool to a driving motor.

In earth-drilling rigs, a drill rod carrying a drilling tool passes through a drilling table. The drill rod is rotatably driven from a suitable motor mounted on the drilling table and power from the motor is transmitted to the drill rod by means of a coupling member. Because of the nature of drilling operations, such coupling arrangements are normally subjected to considerable, and usually intermittent, stresses and strains and are thus particularly liable to rapid wear and, consequently, may frequently require extensive maintenance.

Therefore, it is desirable for the coupling members to be constructed as simply as possible in order to facilitate the carrying out of repairs at the drilling site.

### SUMMARY OF THE INVENTION

According to the present invention there is provided a coupling member for transmitting rotational displacement to a drill rod provided with one or more rib members projecting from the periphery of the rod, the coupling member comprising a bore, through which the drill rod may pass, and one or more expendable bearing strip members detachably mounted on the coupling member and projecting into the bore for cooperating with the or each rib member to transmit rotational displacement to the drill rod.

Preferably, each of the expendable bearing strip members comprises a plurality of parts and is provided with a built-up weld in that region of the respective bearing strip member which is adjacent to a cooperating projecting rib member.

### BRIEF DESCRIPTION OF THE DRAWINGS

An embodiment of the present invention will now be more particularly described with reference to the accompanying drawings, in which:

FIG. 1 shows, in section along I-I of FIG. 2 a coupling arrangement for a drilling tool embodying the invention;

FIG. 2 shows a plan view of the coupling arrangement of FIG. 1; and

FIG. 3 shows an overall view of a drilling rig which utilizes the coupling arrangement of FIGS. 1 and 2.

### DESCRIPTION OF THE PREFERRED EMBODIMENT

Referring now to the drawings, FIG. 3 shows an overall view of an earth-drilling rig comprising a drilling table 2, which is adapted to slide up and down a vertical guide mast 1. The drilling bit is carried on the lower end of a vertical drill rod 8, which is coupled to a motor (not shown) for rotating the drill rod 8. The coupling arrangement comprises a coupling member whose position on the drilling table 2 is indicated in FIG. 1 by the reference 3. The coupling member 3 is rotatably driven through gears and a suitable motor (not shown) and torque is transmitted via the coupling member 3 and the cylindrical drilling rod 8 to rotate a spiral earth-drilling bit carried at the lower end of the drill rod. As indicated in FIGS. 1 and 2, the coupling member 3 is coaxially mounted around the drill rod 8, which is provided with radially projecting rib members 7 which engage cooperating bearing strip members 11 provided on the coupling member 3. The coupling member 3 comprises two annular portions, namely an upper portion 4 and a lower portion 5. Each of these portions 4 and 5 is provided with annular groove 6 which is discontinuous in the region of each of the projecting rib members 7. Annular strip bearing pads 10 are located adjacent the periphery of the casing 9 of the drill rod 8 and expendable bearing strip members

11 are located adjacent each of the projecting rib members 7. As shown in FIGS. 1 and 2, the bearing pads 10 and the bearing strip members 11 fit in the grooves 6. The bearing strip members 11 are reinforced by built-up welds 12 in the regions where they bear on the projecting ribs 7 of the drill rod 8. These built-up welds 12 may project beyond the edges of the grooves 6 so as to provide abutments for transmitting the driving torque to the rib members which project from the circumference of the drill rod.

The bearing pads 10 and the bearing strips 11 can be loosely inserted into the grooves 6, in which they may be secured by appropriate means, such as for example elastic locking elements, in order to facilitate assembly.

Furthermore, the bearing strips 11 may be obliquely faced for adaptation to spiral projecting ribs 7 on the drill rod 8.

The advantage of a coupling arrangement embodying the invention resides in the fact that the coupling member 3 need not be subjected to any difficult machining process, which would entail dismantling the coupling member from the drilling table. If wear occurs, it is necessary only to remove the drill bit from the drill rod so that the latter can be pulled through the drilling table. The worn bearing pads and strips may then be removed and replaced by new pads and strips. This operation can be performed rapidly by unskilled personnel, and further dismantling of the drilling rig is unnecessary.

I claim:

1. A coupling arrangement comprising in combination a drill rod,

a coupling member to transmit rotational movement to said drill rod and disposed coaxially therewith,

at least one rib member provided on said drill rod and projecting from the periphery thereof,

at least one expendable bearing strip member detachably mounted on said coupling member and cooperating with said at least one rib member to couple said coupling member to said drill rod.

2. A coupling arrangement as defined in claim 1, comprising a built-up weld provided on each of said expendable bearing strip members, said built-up weld being provided in that region of each of said expendable bearing strip members located adjacent one of said cooperating rib members.

3. A coupling arrangement as defined in claim 2, wherein each of said expendable bearing strip members comprises a plurality of parts.

4. A coupling arrangement as defined in claim 1, comprising at least one bearing pad strip member mounted on said coupling member and disposed adjacent said periphery of said drill rod.

5. A coupling arrangement comprising in combination; a cylindrical drill rod,

a coupling member to transmit rotational movement to said cylindrical drilling rod, said coupling member comprising annular portions disposed concentrically of said cylindrical drill rod and surrounding the circumference thereof,

at least one expendable bearing strip member detachably mounted on each of said annular portions of said coupling member to couple said coupling member to said cylindrical drill rod.

6. A coupling arrangement as defined in claim 5, wherein said rod has at least one radially projecting rib member, an annular groove being defined in each of said annular portions of said coupling member, each of said grooves being disposed substantially concentrically of said cylindrical drill rod and being discontinuous in the region of each of said radially projecting rib members and at least one of said bearing strip members being secured in each of said annular grooves.

7. A coupling arrangement as defined in claim 6, comprising at least one bearing pad strip member secured in each of said annular grooves, each of said bearing pad strip members being disposed adjacent the circumference of said cylindrical drill rod.