



US 20070145073A1

(19) **United States**

(12) **Patent Application Publication**
Morini

(10) **Pub. No.: US 2007/0145073 A1**

(43) **Pub. Date: Jun. 28, 2007**

(54) **TUBE MADE OF A PLASTIC MATERIAL**

Publication Classification

(75) Inventor: **Emilio Morini**, Colorno (IT)

Correspondence Address:
YOUNG & THOMPSON
745 SOUTH 23RD STREET
2ND FLOOR
ARLINGTON, VA 22202 (US)

(51) **Int. Cl.**

B65D 35/00 (2006.01)

B65D 47/00 (2006.01)

(52) **U.S. Cl.** **222/107; 222/546; 222/556**

(73) Assignee: **BORMIOLI ROCCO & FIGLIO**
S.P.A., PARMA (IT)

(57) **ABSTRACT**

(21) Appl. No.: **10/582,874**

(22) PCT Filed: **Dec. 15, 2003**

(86) PCT No.: **PCT/IT03/00816**

§ 371(c)(1),
(2), (4) Date: **Jun. 14, 2006**

The tube exhibits a lower part (1a), which is open for introduction of a product and closable after the introduction, and an upper part (1b) which exhibits a passage-hole (2) for exit of the product from the tube. The upper part (1b) comprises an opening (3), which is larger than the passage-hole (2) and arranged in a zone of the upper part (1b) in which the passage-hole (2) is to be made. A reducer element (4) sealingly fits in the opening (3) and exhibits the passage-hole (2).

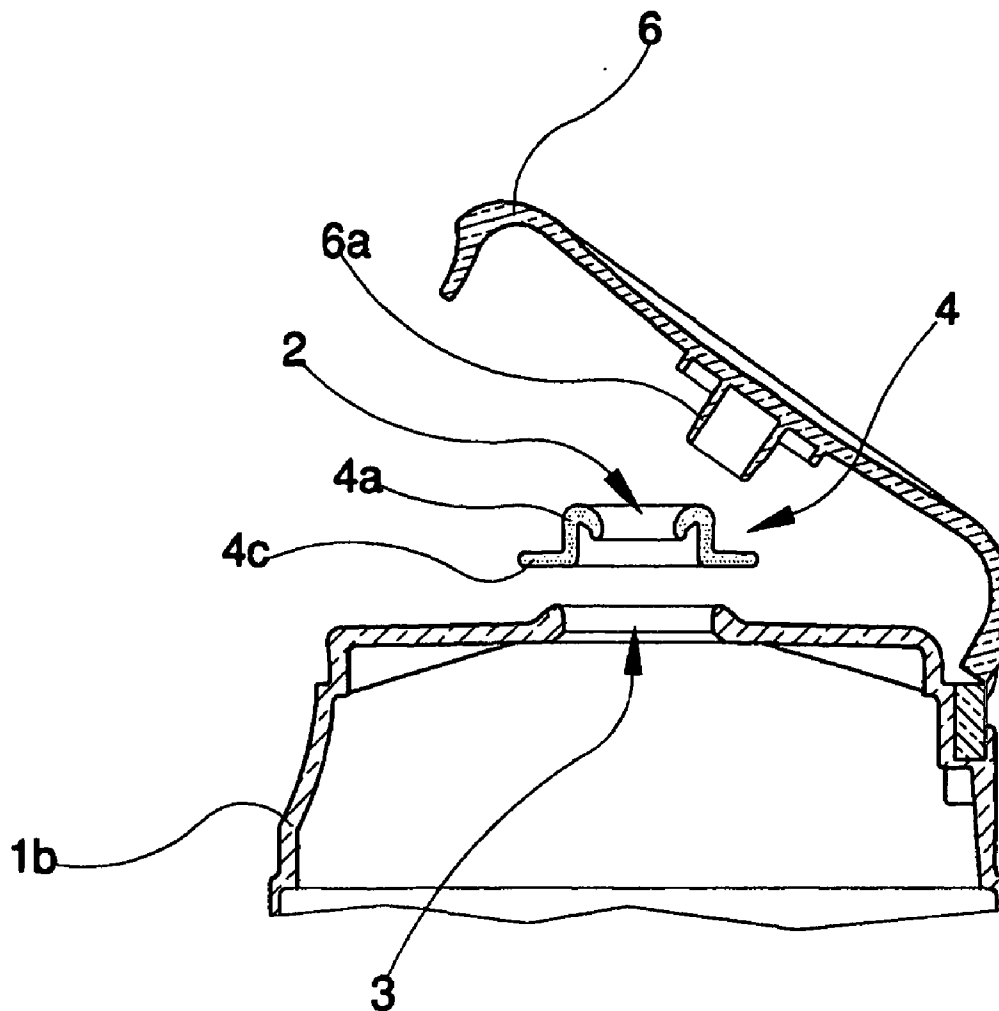

Fig. 1

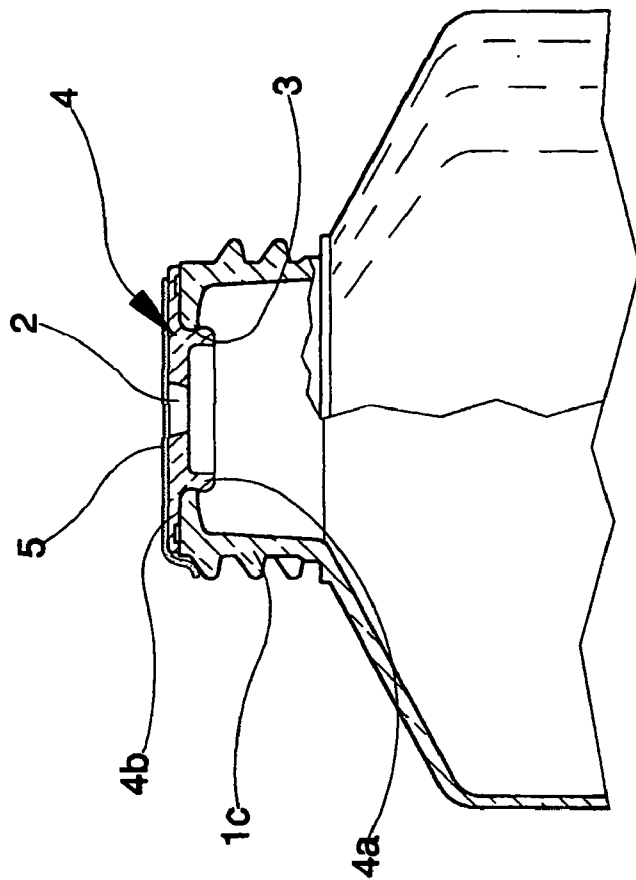
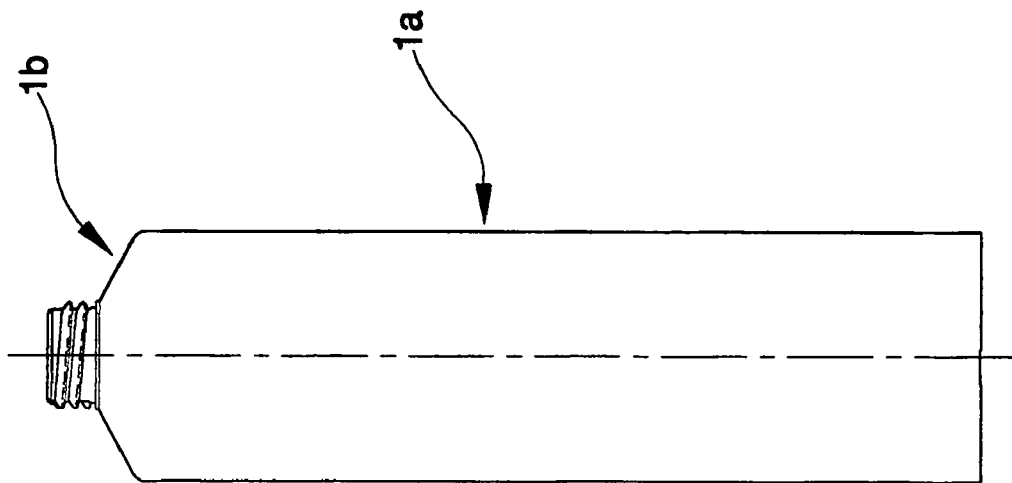

Fig. 2

Fig. 3

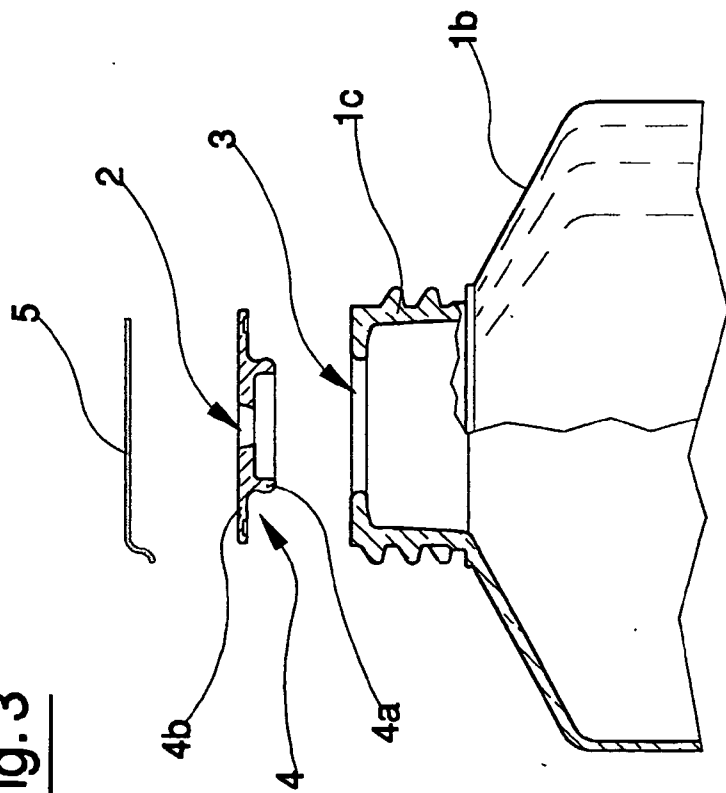

Fig. 6

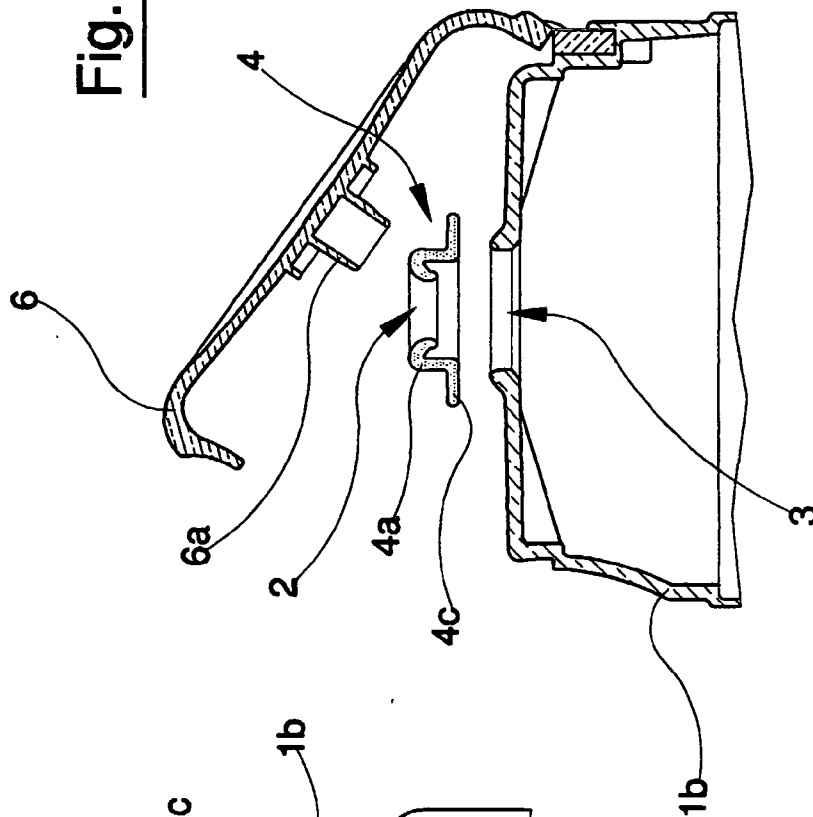

Fig. 4

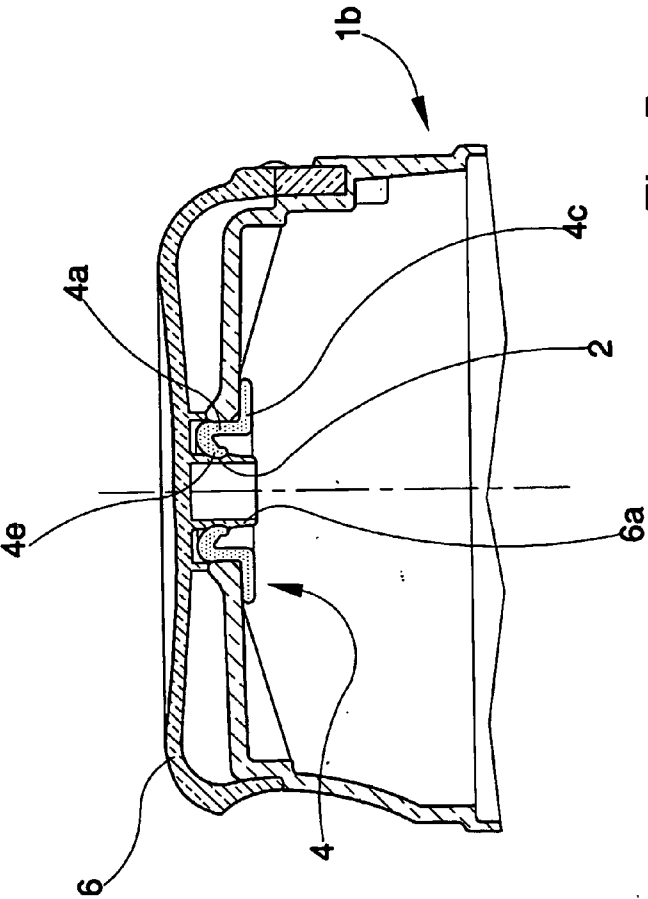
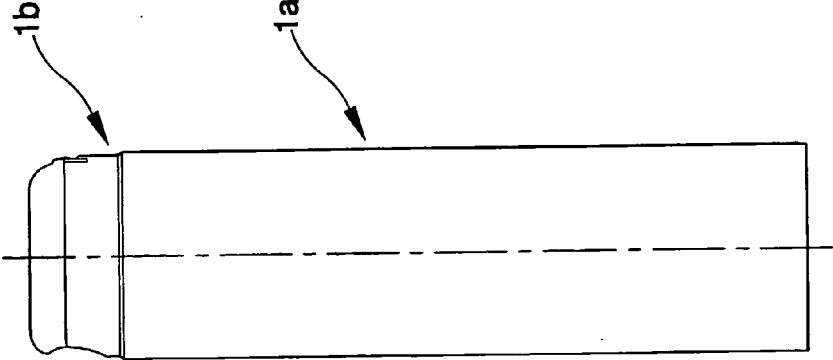

Fig. 5

TUBE MADE OF A PLASTIC MATERIAL

TECHNICAL FIELD

[0001] The invention relates to an improved tube made of a plastic material.

BACKGROUND ART

[0002] The prior art contains tubes made of a plastic material, which are used in substitution of metal tubes. Reference is made especially to tubes destined to contain fluid products such as cosmetic creams and cosmetic products in general. These tubes usually comprise an open lower part for introduction of the product, which lower part can be permanently closed after the product has been introduced. They also comprise an upper part which includes a passage hole for the exit of the product from the tube. These tubes are made either by welding the upper part, generally produced by injection-moulding, to a drawn cylindrical tube, or by pressing the whole tube in one piece, using plastic material injection techniques in a shaped die.

[0003] The tubes thus manufactured are sent on to the cosmetic producer who fills them by introducing the product via the open bottom, then welds the tubes closed and removably closes the top part thereof by applying a cap which will enable the user to open the tube to obtain the product in the necessary doses and also to close the tube before a next use thereof. The closure of the passage hole is generally obtained either by a screw-cap screwed onto a thread provided at the passage hole, or by a pressure-fit cap provided with a stalk which inserts sealingly in the passage hole.

[0004] As with all objects having a modest unit cost but high production numbers, the main problem the producers have to face and solve is how to limit production costs by using standardised dies able to produce a high number of pieces before deteriorating, and limiting the production waste levels.

[0005] Production waste is largely due to a manufacturing difficulty relating to the upper part of the tube, especially the passage hole. The part of the die which is shaped to mould the hole is the part which is most stressed by the thrusts generated during the injection stage of the upper part of the tube (in particular the whole tube if it is moulded by injection in a single piece). This leads, after a period of use of the die, to the onset of misalignments which cause intolerable errors in the shapes, the thicknesses and the coaxial qualities of passage-holes of the tubes. The main aim of the present invention is to obviate the above-mentioned drawbacks in the prior art by providing a tube which can be manufactured using dies able to produce a high number of pieces without deteriorating.

[0006] An advantage of the invention is that it enables a higher standardisation of the dies used for manufacturing the tubes, in particular those dies which are more complex and expensive.

[0007] These aims and advantages and others besides are all achieved by the present invention, as it is characterised in the appended claims.

DISCLOSURE OF INVENTION

[0008] Further characteristics and advantages of the present invention will better emerge from the detailed

description that follows, of preferred but not exclusive embodiments thereof, illustrated purely by way of example in the accompanying figures of the drawings, in which:

[0009] FIG. 1 is a section in vertical elevation of a first embodiment of the tube of the invention;

[0010] FIG. 2 is an enlarged-scale view of a detail of FIG. 1 relating to the upper part of the tube;

[0011] FIG. 3 is a detail of FIG. 2 with the elements of the upper part of the tube detached from each other;

[0012] FIG. 4 is a section in vertical elevation of a second embodiment of the tube of the invention;

[0013] FIG. 5 is an enlarged-scale view of a detail of FIG. 4 relating to the upper part of the tube;

[0014] FIG. 6 is a detail of FIG. 5 with the elements of the upper part of the tube detached from each other.

[0015] The tube of the invention comprises, like known-type tubes, an open lower part *1a*, through which producers of the products the tube is destined to contain introduce the product. The lower part of the tube is closable after filling, for example by heat welding. The tube also exhibits an upper part *1b* in which a passage hole is afforded for exit of the product from the tube for use by the final user.

[0016] Also as in known-type tubes, the tube can be made either by welding the upper part, generally obtained by injection moulding, to a drawn cylindrical tube, or by directly pressing the whole tube by injection of plastic material into a special die. The tube can be of a type comprising a threaded mouth *1c*, cylindrical in shape and receiving a screw-cap at its top. This type of tube is illustrated in FIGS. 1, 2 and 3. The tube can be a type comprising a pressure-fit cap *6* which is hinged to the body of the tube and is provided with a stalk *6a* that inserts sealingly in the passage hole *2* and closes the hole. This type of tube is illustrated in FIGS. 4, 5 and 6. The known-type tubes exhibit various overall dimensions which depend on a volume of product to be inserted therein, and various passage-hole diameters depending on a quantity of product to be extracted from the tube.

[0017] The upper part *1b* of the tube comprises an opening *3* which is larger than dimensions of the passage-hole *2* and which is made, during the moulding of the upper part, in the zone of the upper part from which the passage hole will be made. As can be seen in the figures, the opening *3* has a circular section and is made on a plane which is perpendicular to the axis of the tube. During the injection-moulding process, whether only the upper part is moulded, which will thereafter be connected to the lower part of the tube, or whether the whole tube is moulded in a single injection stage, a much larger hole is obtained than the hole which is required for the finished tube. This enables use of dies which, with reference to the parts thereof which form the hole *3* and the zones surrounding the hole *3*, are of sizes which enable a resistance to the stresses that develop on the die during the injection stage, which resistance is considerably greater than that of dies which would directly produce the passage-hole *2*. The dies can thus produce a much higher number of pieces with respect to dies at present in use, without creating any defects, especially coaxial defects, in the various elements of the tube. The dies therefore have a considerably longer working life than dies at present in use.

[0018] The cap of the invention further comprises a reducer element 4 which is separately made by press-forming or another known method, and which is shaped in such a way as to sealingly fit in the opening 3. The passage-hole 2 is afforded in the reducer element 2, as will be better described herein below.

[0019] The insertion of the reducer element in the opening 3 can easily be done in a work station subsequent to the pressing station, for example in a finishing station where the surface of the tube is finished or a decoration applied thereon.

[0020] In particular the reducer element 4 is a sort of disc comprising an external ring 4a which is slightly bigger than the opening 3 and which, on mounting, pressure-fits therein, sealingly closing the opening 3. The passage hole 2, made of a desired size, is afforded concentrically of the external ring 4a.

[0021] Given the small size of the reducer element with respect to the whole tube, the manufacturing of the reducer element is considerably easier with respect to the making of the whole tube with the passage-hole directly produced by press-forming, and the dies needed to obtain the reducer element 4 and the tube with the opening 3 instead of the passage-hole 2 are extremely simple. Take, for example, a tube which needs a passage-hole having a diameter of one or two millimetres, such as for example the tubes for very fluid creams. Manufacturing known-type tubes having these characteristics is practically impossible as the element of the die destined to make the passage-hole, necessarily of a very small diameter, would deteriorate after a very short period of working life due to the thrusts unloaded onto it during the plastic material injection stage. With the tube of the invention this type of realisation does not present any problems of this nature since the die for making the tube is provided with a very big diameter hole-making element (equal to the diameter of the opening 3). The passage hole 2, however small, is made during the moulding stage of the reducer element, thus creating no problems since the element is of very small overall size and the die to realise it can also be very small.

[0022] It is also possible to have standardised tubes for various forms of tube, determining the internal volume thereof, which create a standardised opening 3; likewise there can be several very economical and simple dies realising reducer elements 4 with various passage-hole 2 dimensions. In this way a considerable range of tubes can be produced at extremely limited expense regarding the dies. In tubes comprising the threaded mouth 1c, such as the ones illustrated in FIGS. 1, 2, and 3, the reducer element 4 advantageously comprises a disc 4b which rests on the threaded mouth when the reducer element 4 is fitted in the opening 3. A film 5 is generally provided which is heat-welded onto the upper part of the disc 4b so as to close the passage hole 2; this film is detached by the user on first using the tube and serves as a security seal for the contents of the tube.

[0023] In tubes comprising a pressure-fit cap 6, with a stalk 6a, such as those illustrated in FIGS. 4, 5 and 6, the reducer element 4 comprises an annular crown 4c which rests on the internal wall of the upper part of the tube when the reducer element 4 is fitted into the opening 3. An internal ring is also included, concentric to the external ring 4a, which defines the passage-hole 2 and houses the stalk 6a.

[0024] In all of the embodiments described the external ring 4a can advantageously be provided with projecting edges so as to guarantee the stability of the reducer element 4 in the opening 3. The projecting edges will be made in the upper or lower part of the ring 4a according to whether the reducer element 4 is inserted in the opening 3 respectively from the inside (FIGS. 4, 5, 6) or the outside (FIGS. 1, 2, 3) of the tube.

[0025] As has been mentioned, both the upper and lower parts of the tube, and also the reducer element 4, are made of a plastic material. The plastic material used to obtain the upper and lower parts of the tube and the reducer element is a soft plastic, such as for example polyethylene. In tubes having a pressure-fit cap 6, in particular those in which the lower part 1a and the upper part 1b including the pressure-fit cap 6 are made in a single piece, obtained by multiple injection moulding, the pressure-fit cap 6 is made of a different plastic material, being harder than the material used for obtaining the rest of the tube. In particular the pressure-fit cap 6 is made of polypropylene. The pressure-fit cap 6 can also be made using the multiple injection-moulding process, which enables moulding to be made together with the moulding of the whole tube, with differently-coloured materials to those of the rest of the tube.

[0026] Making the tube and the reducer element 4 of soft plastic facilitates the insertion of the reducer element 4 in the opening 3 and improves the seal between the reducer element 4 and the opening 3, even where surface finishing of the contact surfaces is not particularly perfected, as the deformation of the material compensates for any surface roughness of the contact surfaces.

[0027] The fact that the cap 6 is made of a harder plastic guarantees a good seal between the stalk 6a and the hole 2 and at the same time makes the opening and subsequent closing of the tube by the user easier. Furthermore, the realisation of the cap 6 with the indicated material, injected directly during the moulding of the material of the rest of the tube and thus blended therein, makes the hinge connecting the cap 6 to the rest of the tube much stronger, and enables a large number of different openings and closures of the tube to be made without breaking the hinge.

1-9. (canceled)

10. An improved tube made of a plastic material, comprising a lower part (1a) which is open for introduction of a product and closable after the introduction, and an upper part (1b) which exhibits a passage-hole (2) for exit of the product from the tube, the upper part (1b) comprising an opening (3), which is larger than the passage-hole (2) and is arranged in a zone of the upper part (1b) in which the passage-hole (2) is to be made; the tube comprising a reducer element (4) in which the passage-hole (2) is made, which reducer element (4) is conformed and arranged in order to fit sealingly in the opening (3); characterised in that it comprises a threaded mouth (1c) having a cylindrical shape and onto which a closure cap is screwed, at which threaded mouth (1c) the opening (3) is afforded, the reducer element (4) comprising a disc (4b) which rests superiorly on the threaded mouth when the reducer element (4) is fitted into the opening (3), the reducer element (4) comprising a film (5) which is

heat-welded onto an upper part of the disc (4b) in order to close the passage-hole (2).

11. The tube of claim 10, wherein: the opening (3) has a circular section and is made on a perpendicular plane to an axis of the tube; the reducer element (4) comprises an external ring (4a) which fits into the opening (3); the passage-hole (2) is arranged concentrically to the external ring (4a).

12. The tube of claim 11, comprising a pressure-fit cap (6) provided with a stalk (6a) which sealingly inserts into the passage-hole (2), wherein the reducer element (4) comprises: an annular crown (4c) which rests on an internal wall of the upper part of the tube when the reducer element (4) fits into the opening (3); an internal ring which is concentric to the external ring (4a), and which defines the passage-hole (2) and is destined to house the stalk (6a).

13. The tube of claim 10, wherein the upper part (1b) of the tube is made by injection moulding.

14. The tube of claim 10, wherein the lower part (1a) and the upper part (1b) of the tube are made in a single piece by injection moulding.

15. The tube of claim 12, wherein the pressure-fit cap (6) is made of a material which is different to and harder than a remaining part of the tube; the reducer element (4) being made of a same material as the remaining part of the tube.

16. The tube of claim 15, wherein the pressure-fit cap (6) is made of polypropylene; the remaining part of the tube and the reducer element (4) are made of polyethylene.

17. The tube of claim 10, comprising a pressure-fit cap (6) provided with a stalk (6a) which sealingly inserts in the passage-hole (2), wherein: the pressure-fit cap (6) is made of a material which is different to and harder than a material used for a remaining part of the tube and is made by multiple injection-moulding of different plastic materials in a single piece with the remaining part of the tube.

* * * * *