

A. B. DICK.  
STENCIL PRINTING MACHINE.

(No Model.)

(Application filed June 10, 1899.)

5 Sheets—Sheet 1.

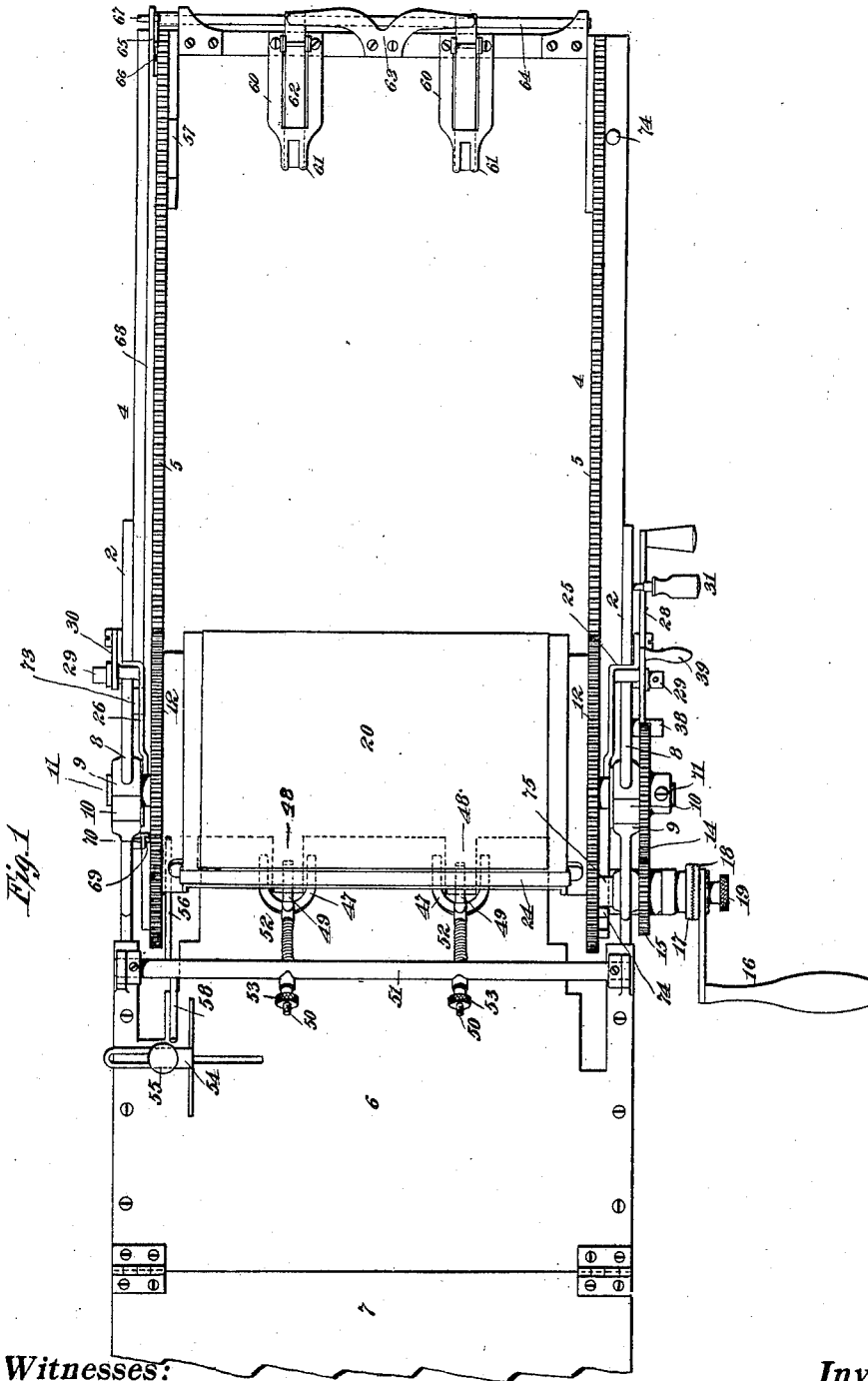

Fig. 1

Witnesses:

*Just. F. Weman*  
*Geo. R. Taylor*

Inventor

*Albert B. Dick*  
 By *Wm. Edmunds*  
 Att'ys.

No. 679,140.

Patented July 23, 1901.

A. B. DICK.  
STENCIL PRINTING MACHINE.

(Application filed June 10, 1899.)

(No Model.)

5 Sheets—Sheet 2.

Fig. 2

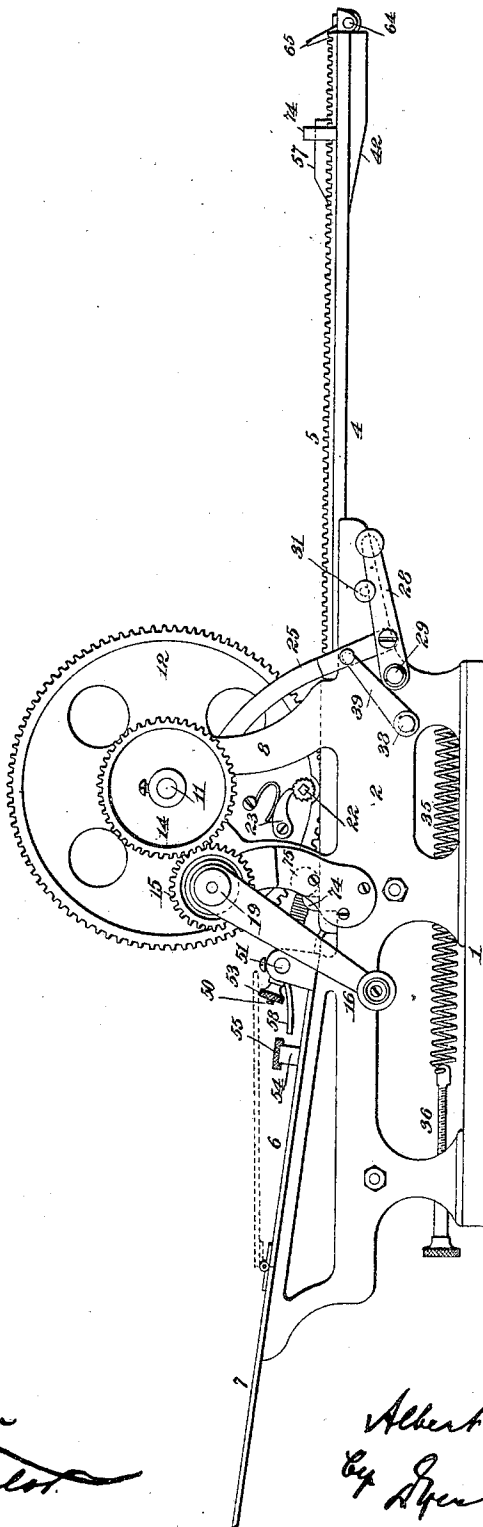

Witnesses:

*Jas. T. Coleman*  
*Geo. A. Taylor*

Inventor

*Albert B. Dick*  
*By [Signature] [Signature]*  
Att'ys.

A. B. DICK.  
STENCIL PRINTING MACHINE.

(Application filed June 10, 1899.)

(No Model.)

5 Sheets—Sheet 3.

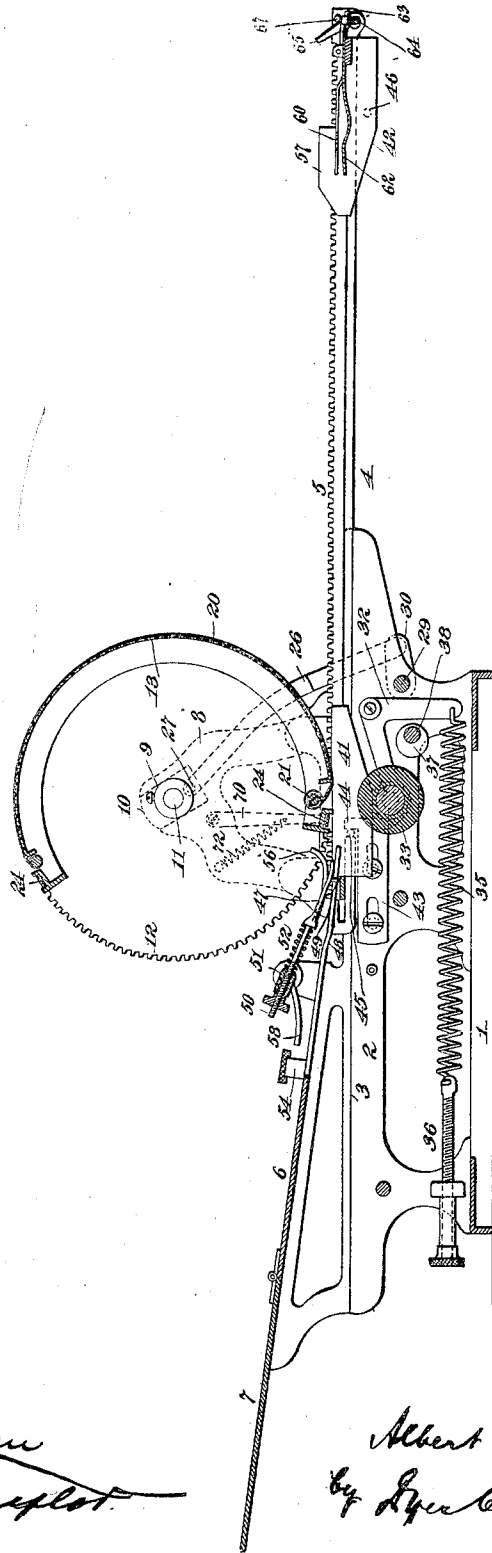

Fig. 3

Witnesses:

*Jas. S. Coleman*  
*Geo. R. Taylor*

Inventor

*Albert B. Dick*  
 by *Edmund A. ...*  
 Att'ys.

A. B. DICK.  
STENCIL PRINTING MACHINE.

(Application filed June 10, 1899.)

(No Model.)

5 Sheets—Sheet 4.

Fig. 4

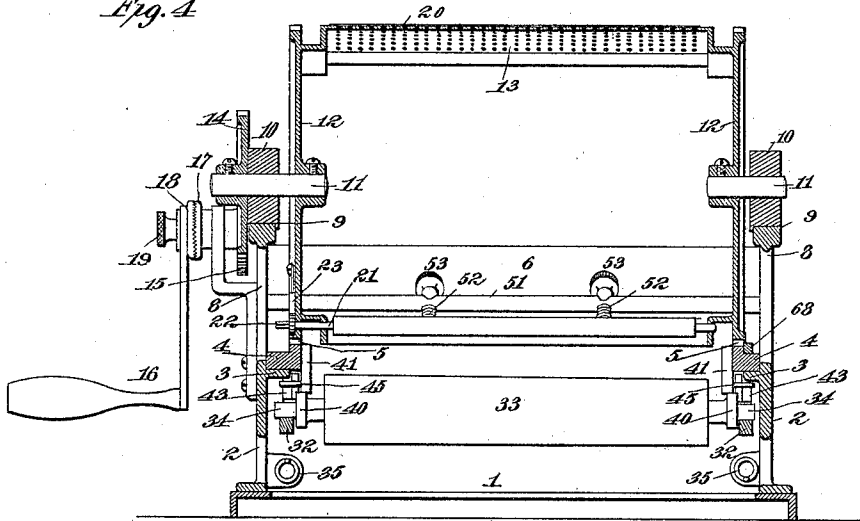
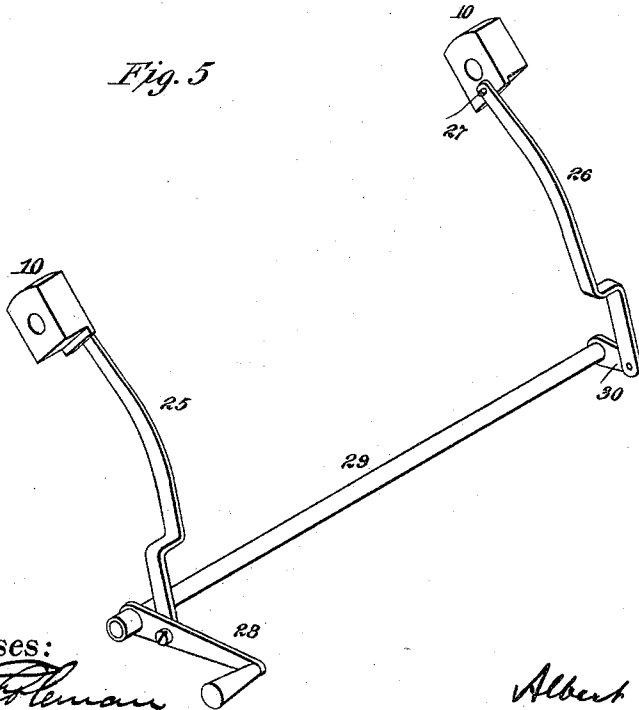

Fig. 5



Witnesses:

*Just Folman*  
*Geo. A. Taylor*

Inventor

*Albert B. Dick*  
 By *Edmund A. Dick*  
 Att'ys.

A. B. DICK.  
STENCIL PRINTING MACHINE.

(No Model.)

(Application filed June 10, 1899.)

5 Sheets—Sheet 5.

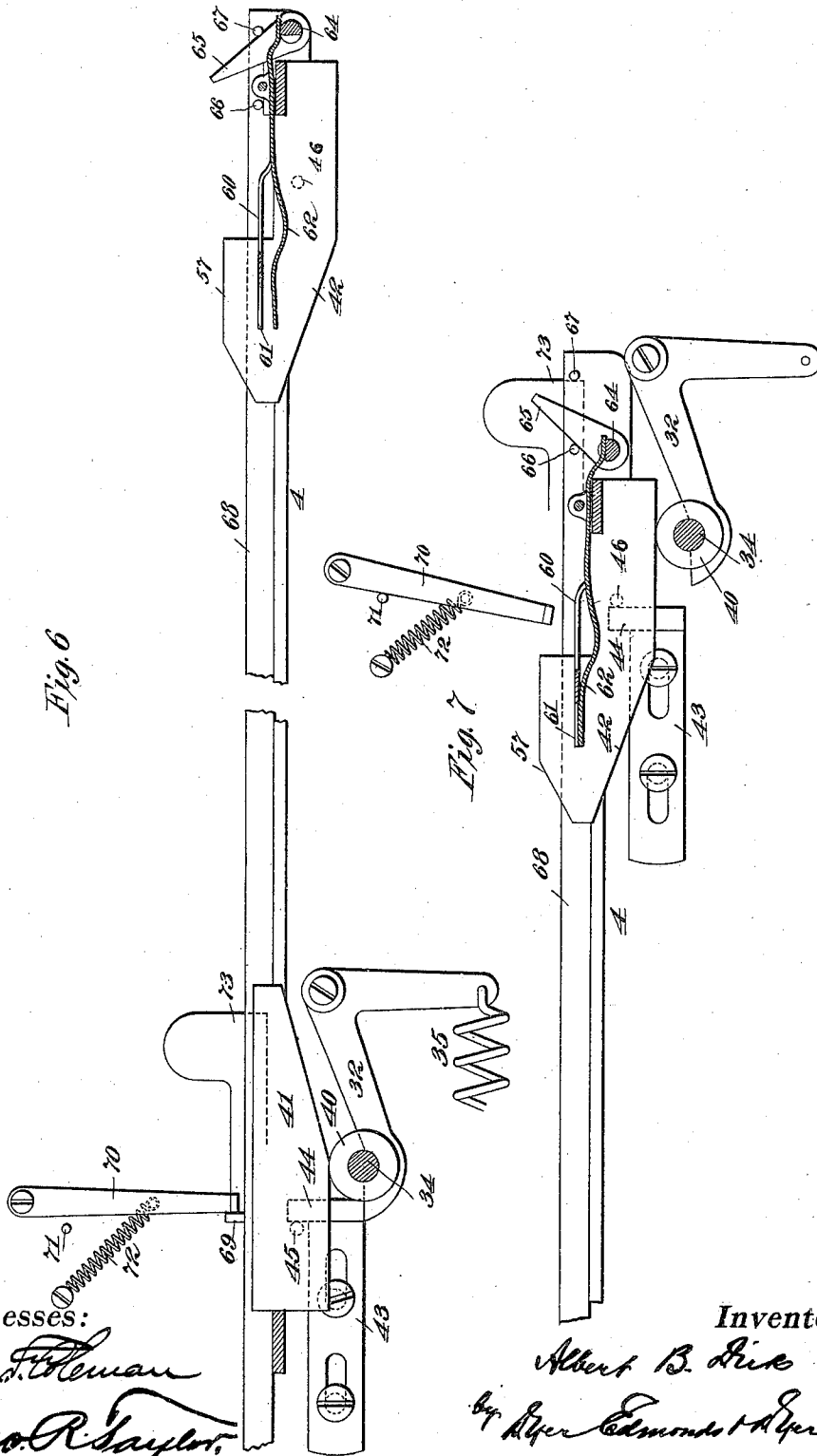

Witnesses:

*Jas. F. Coleman*  
*Geo. R. Taylor*

Inventor

*Albert B. Dick*  
*By Alfred Edmunds*

Att'ys.

# UNITED STATES PATENT OFFICE.

ALBERT B. DICK, OF CHICAGO, ILLINOIS, ASSIGNOR TO THE A. B. DICK COMPANY, OF SAME PLACE.

## STENCIL-PRINTING MACHINE.

SPECIFICATION forming part of Letters Patent No. 679,140, dated July 23, 1901.

Application filed June 10, 1899. Serial No. 720,008. (No model.)

*To all whom it may concern:*

Be it known that I, ALBERT B. DICK, a citizen of the United States, residing at Chicago, in the county of Cook and State of Illinois, have invented a certain new and useful Improvement in Stencil-Printing Machines, of which the following is a specification.

My invention relates to new and useful improvements in machines for printing from stencil-sheets, and particularly from mimeographic work, wherein the stencil is formed in a wax-coated fibrous sheet.

The object of the invention is to provide a cheap and efficient stencil-printing machine which will be capable of being easily operated and which will turn out very perfect copies. At the present time with the stencil-printing machines now in use the tendency of the work to become more or less smeared is almost inevitable; but with my improved machine the danger of imperfect copies being made is entirely overcome.

My invention resides principally in the combination, with an oscillating stencil-carrier, of an impression-roller cooperating with the carrier and adapted to press the sheet to be printed against the stencil and a reciprocating paper-carrying frame arranged to draw the sheet being printed between the stencil and the impression-roller and at the same rate as the peripheral movement of the stencil, whereby a perfectly clean clear copy will be secured without any danger of smearing.

My invention further resides in the combination, with an oscillating stencil-carrier, of an impression-roller cooperating therewith and arranged to press the sheet being printed into contact with the stencil during the movement of the stencil in one direction and to be withdrawn during the reverse movement, whereby the paper-carrying frame may engage a new sheet for movement between the stencil and the impression-roller.

My invention further resides in the combination, with a stencil-carrying device, of a paper-feeding frame movable with respect to the same, an impression-roller for forcing the sheet into contact with the stencil, and suitable adjusting means whereby the stencil may be caused to be imprinted upon the sheet at any desired position upon the latter.

My invention further resides in the combination, with a stencil-carrying device, of a paper-feeding frame for moving the sheet to be printed at the same rate as that of the stencil, said paper-carrying frame being provided with grippers which engage the sheet to be printed, draw it along in contact with the stencil, and release it after the printing has been effected, whereby the sheet will drop flatwise into a receiving-box.

The invention also resides in the provision, with an oscillating stencil-carrying device, of a handle for moving it and means for adjusting the position of said handle with respect to that of the stencil, whereby irrespective of the position of adjustment of the stencil the handle may be always arranged to start from a natural and normal position convenient to the operator.

My invention also resides in improvements connected with the stencil-carrying device, which comprises an oscillating perforated metallic sheet having a cloth pad on its outside upon which the stencil is placed. I do not use an ink-roller with my improved machine, since I have found that excellent results are secured by simply painting or smearing the interior of the oscillating stencil-carrier with a suitable relatively thin ink, which by suction will be caused to automatically supply the stencil. I find in practice that by employing a relatively thin film of ink several hundred copies can be obtained.

The invention further resides in the provision of improved means for tightening the cloth pad, which is interposed between the stencil and its oscillating carrier and by reason of which the pad may be placed in an absolutely smooth and tight condition.

There are other features of novelty in my improved stencil-printing machine, which will be referred to in detail when the mechanical construction of the machine is explained.

In order that the invention may be better understood, attention is directed to the accompanying drawings, forming a part of this specification, and in which—

Figure 1 is a plan view; Fig. 2, a side elevation; Fig. 3, a longitudinal section; Fig. 4, a transverse section; Fig. 5, a detail perspective view of the bearings for the oscil-

lating stencil-carrier, illustrating the mechanism for moving said bearings; Fig. 6, a detail section of the carriage, illustrating the mechanism for operating the paper-gripping fingers and one of the latches for holding the impression-roller out of engagement on the negative stroke, the carriage being in its outermost position, with the paper-gripping fingers open; and Fig. 7, a similar view showing the carriage in its innermost position with the paper-gripping fingers closed.

In all of the above views corresponding parts are represented by the same numerals of reference.

1 is a rectangular bed to which the side frames 2 2 are secured. The side frames 2 2 are formed with tracks 3, and working on said tracks is a frame 4, the side members of which are provided with racks 5 5. The sheets to be printed are carried on a table 6, having, preferably, a hinged extension 7, which can be turned over to shorten the length of the machine when not in use. Each of the side frames 2 is provided with a cast extension 8, formed with a slotted bearing 9 on its top. Mounted in each of these bearings is a bearing-box 10 for the spindle 11 of a toothed disk 12, two of these disks being used. Connecting the toothed disks 12 is a perforated metallic sheet 13, which, together with the said disks, constitutes an oscillating stencil-carrier. In order to oscillate this stencil-carrier, I provide the spindle 11 of one of the disks 12 with a gear 14, with which meshes a pinion 15, operated from a crank 16. The shaft of the pinion is provided with a serrated disk 17, and the crank 16 is provided with a corresponding disk 18, a thumb-screw 19 being employed to hold the said serrated disks in engagement. By loosening the screw 19 it will be observed that the handle 16 may be adjusted to any position with respect to the oscillating stencil-carrier. Carried upon the perforated plate 13 is a sheet or pad 20 of suitable textile material. One end of this sheet is stitched over upon a bar or rod to secure the sheet, and the other end of said sheet is passed through a longitudinally-slotted shaft 21, extending beyond one of the disks 12 and formed with a rectangular head 22 for the reception of a key. A spring-pressed pawl 23 is employed to lock the shaft 21 normally in any position to which it may be turned. By turning the shaft 21 with a suitable key the sheet or pad 20 can be stretched very tightly upon the perforated sheet 13. The stencil-sheet is placed in position over the pad 20 and held in any suitable way—as, for instance, by the ordinary clips 24.

The toothed disks 12 engage the rack portions 5 of the side pieces of the frame 4, whereby the oscillating movement, first in one direction and then in the other, of the disks 12 will provide for a reciprocation of the frame 4, and by properly proportioning the disks 12 the movement of the frame 4 will

correspond exactly with the surface velocity of the stencil. In order to hold the toothed disks 12 normally in engagement with the racks 5 of the paper-carrying frame 4, I employ links 25 and 26, which engage with the pins 27, formed on the bearing-blocks 10. The link 25 connects with a finger-lever 28, which is carried upon a rock-shaft 29, having a crank 30 at its opposite end, to which the link 26 is connected. By elevating the lever 28 the links 25 and 26 will elevate the bearing-blocks 10, so as to disengage the toothed disks 12 from the racks 5. The stencil-carrying frame may now be moved to bring the stencil to any desired position of adjustment relative to the paper-carrying frame, when the parts will be again engaged by depressing the finger-lever 28. The lever 28 is normally locked in its lower position to maintain the engagement of these parts by a pin 31 engaging an opening in one of the side frames. By removing the upper ends of the links 25 and 26 entirely from the pins 27 the oscillating stencil-carrier as a whole may be removed for any purpose.

Pivoted to each of the side frames 2 is a bell-crank 32, and mounted in these bell-cranks is an impression-roller 33, made, preferably, principally of rubber. The spindle 34 of the impression-roller is carried at its ends in open bearings in the bell-cranks 32, whereby the impression-roller may be removed for any purpose. Each of the bell-cranks 32 is operated by a spiral spring 35, by which the impression-roller will be elastically impelled upward into contact with the stencil or the sheet in engagement therewith when an impression is desired. The springs 35 are adjusted by the adjusting-screws 36 of ordinary construction. In order to move the impression-roller 33 out of engagement with the stencil, I employ an eccentric 37, engaging with each of the bell-cranks, as shown, said eccentrics being carried on a rock-shaft 38, to the outer end of which is keyed a finger-lever 39. By operating the finger-lever the rock-shaft will be turned, engaging the eccentrics with the vertical arms of the two bell-cranks and moving the impression-roller positively downward. The impression-roller 33 is provided at each end on its spindle 34 with an antifriction-roller 40, with which the under surfaces of the sides of the frame 4 normally engage. At each end of the stroke of the frame 4 a cam 41 or 42 engages each of the antifriction-rollers 40 to move the impression-roller downward out of engagement with the stencil-sheet or with the sheet being printed. Co-operating with the horizontal arm of each of the bell-cranks 32 is a latch 43, having a shoulder 44 thereon, with which a pin 45, carried on each of the cams 41, is adapted to engage, whereby when the cams 41 have engaged the antifriction-rollers 40 to depress the impression-roller the pins 45 will engage the lugs 44 of the slides 43 to move the latter over the horizontal arm of each of the bell-

cranks 32 to lock the latter in their depressed position. Each of the cams 42 is provided with a pin 46, adapted to engage the lug 44 of the corresponding lock 43 when the frame 4 5  
nears the completion of its negative stroke—*i. e.*, the stroke upon which a printing operation does not take place. By the arrangement of cams which I have described the frame 4 when it approaches the end of its  
10 positive stroke causes the cams 41 to depress the impression-roller, and after such impression-roller has been depressed the pins 45 on the cams 41 will engage the latches 43 to hold the impression-roller locked downward. During  
15 the entire negative stroke, therefore, the impression-roller will remain locked in its depressed position. Near the completion of the negative stroke the cams 42 engage the anti-friction-rollers 40, so as to depress the impres-  
20 sion-roller to a very slight further extent, and the pins 46 engage the latches 43 to release them from the bell-cranks 32. Upon the starting of the positive stroke the cams 42 will allow the impression-roller to be forced  
25 upward into contact with the sheet being printed by the tension of the springs 35. In this way it will be observed that the impression-roller is maintained in an inactive condition during the entire negative stroke and  
30 is allowed to be impelled upward always at the same instant in the travel of the paper-carrying frame 4 during its positive stroke.

By suitably adjusting the position of the stencil relative to the reciprocating frame 4,  
35 as I have described, it becomes possible to secure the printing of stencil matter within very close limits of adjustment. Where finer adjustment is necessary, I provide the regulation of the length of the limiting-fingers  
40 which determine the position of the sheet as fed by the operator. These fingers preferably comprise a fork-like head, the outer tines 47 of which bear upon the surface of the table 6 around an opening 48, and the central  
45 tine 49 being provided with a downturned finger, as shown, which forms an adjusting-stop to the sheet. The shank 50 passes through a rock-shaft 51, as shown, and a spring 52 maintains the fingers in their outermost  
50 position, a very fine adjustment being permitted by the adjusting-screw 53. By regulating the distance of the limiting-fingers 49 with respect to the shaft 51 an accurate adjustment of the sheet will be permitted. In order to  
55 regulate the position of the sheets sidewise, I employ the usual gage 54, the position of which is regulable by an adjusting-screw 55, working in a slot, as is common. When the sheet of paper to be printed has been moved  
60 by the operator into engagement with the fingers 49 and the gage 54 and the frame 4 returns on its negative stroke to grasp the paper and draw it through the machine between the stencil and the impression-roller, it is  
65 necessary to elevate the fingers 49 from the sheet to permit this to be done, and to accomplish

this result I employ an arm 56, which is carried on the rock-shaft 51 and which engages a cam 57, formed integrally with the cam 42,  
as shown. A rearwardly-extending arm 58 70  
prevents overthrow of the rock-shaft 51.

The grippers for engaging the sheets and drawing them through the machine are carried on the frame 4. Each comprises, preferably, a stationary top member 60, having the  
75 two prongs 61 61 and the bottom member 62 pivoted thereto. The members 62 are normally pressed upward into engagement with the prongs 61 by a leaf-spring 63, as shown. In order to separate the grippers, I extend the  
80 movable member 62 backward, as shown, and engage it in a cut-away portion of a rock-shaft 64, which when partially turned will obviously elevate the rear ends of the members 62 to separate their forward extremities. This  
85 rock-shaft 64 carries an arm 65 at one of its extremities, which arm is adapted to be moved in one direction or the other by the engagement with it of pins 66 and 67, carried on a  
90 slide 68, which extends parallel to one of the side members of the frame 4. The slide 68 carries a pin 69, adapted to engage the lower end of a lever 70, which is normally held in engagement with a stop-pin 71 by a spring 72. The pin 67 is extended through the slide 68  
95 and is adapted to engage a lug 73 on the side frame 2, almost at the very end of the completion of the negative stroke, whereby at that moment the paper-carrying frame 4 will be moved relatively to the slide 68, causing the  
100 rock-shaft 64 to be partially rotated and allowing the fingers 61 and 62 to grip the sheet through the pressure of the spring 63. The movement of the paper-carrying frame 4 is limited both at the end of its positive and  
105 negative strokes by the engagement of pins 74 with an elastic stop or buffer 75, carried on each of the side frames 2.

The operation will be as follows: The stencil-sheet or other stencil is secured by the  
110 clips 24 or in any suitable way smoothly and evenly upon the cloth sheet or pad 20 around the oscillating stencil-carrier. A suitable relatively thin ink is now applied to the interior of the perforated sheet 13 by means of  
115 a brush or sponge to form a comparatively thin film or coating. This ink exudes through the pad or sheet 20 and passes through the perforations in the stencil. As it is consumed in the making of the copies, I find that  
120 the atmospheric pressure to which it is subjected will maintain a very uniform and effective supply of ink at all times in the stencil-sheet. As the ink becomes exhausted, it is a matter of only a few seconds to apply a  
125 fresh coating. I find in practice that a comparatively thin film of suitable ink applied with a brush will enable several hundred copies of mimeograph-matter to be secured without renewals. Having placed the sten-  
130 cil in position upon the stencil-carrier, it next becomes necessary to adjust the position of

the stencil relative to the sheets to be printed in order that the matter may be properly displayed upon the copies. This is an operation which depends largely upon practical experience, and the proper alinement of the copy is effected, as before stated, by operating the lever 28 to elevate the stencil and to disengage the toothed disks 12 from the racks 5, thus permitting the stencil to be turned to any position that may be desired without effecting the movement of the frame 4, which carries the paper. The proper alinement can be very conveniently made by experimenting with one or two copies and by changing the relative position of the oscillating stencil-carrier to the paper-carrying frame. The parts being in correct alinement, a number of sheets of paper are placed upon the bed 6 and are advanced one at a time by the operator until they come into contact with the fingers 49. The handle 16 is moved by the operator first in one direction and then in the other, the engagement of the pins 74 with the elastic buffers 75 acting effectively as limiting-stops to these movements. Upon the negative stroke of the machine, assuming a sheet of paper to be in engagement with the fingers 49, the rotating of the handle 16 will move the racks 5 and frame 4 rearwardly until the arm 56 of the rock-shaft 51 engages the cam 57, at which time the fingers 49 will be elevated from the sheet. At about this time, however, the grippers 61 and 62 will be opened and will enter the notches 48 of the bed 6, so as to engage over the sheet, while at the completion of the negative stroke the engagement of the pin 67 with the stop 73 will rotate the rock-shaft 64 to permit the springs 63 to operate the grippers 61 62 to close upon the sheet and to draw it by the movement of the frame 4 beneath the stencil. In this movement the sheet will be engaged by the stencil and will be held up in contact with the stencil by the impression-roller. At the completion of the positive stroke, however, after the printing has been effected, the pin 69 on the slide 68 engages the lever 70, and the slide is moved in the reverse direction to separate the grippers 61 and 62 and permit the sheet to fall flatwise in a suitable receiving-box placed at one side of the machine. During the negative stroke of the machine it is of course necessary that the impression-roller should be withdrawn from the stencil in order that it may not become smeared with ink and also to permit the grippers 61 and 62 to pass between the impression-roller and the stencil to grasp the new sheet. This movement of the impression-roller is effected, as explained, by the cams 41 and 42, the former depressing the impression-roller, which will be locked by the latches 43, while the latter cams 42 depress the impression-roller and subsequently withdraw the latches, so that upon the positive stroke the impression-roller may be again moved

upward by the springs 35 to force the sheet against the stencil and effect the printing operation.

Having now described my invention, what I claim as new, and desire to secure by Letters Patent, is as follows:

1. In a stencil-printing machine, the combination with an oscillating stencil-carrier, of an impression-roller cooperating with the carrier, and a reciprocating paper-carrying frame arranged to draw the sheet to be printed between the stencil and the impression-roller, substantially as set forth.

2. In a stencil-printing machine, the combination with an oscillating stencil-carrier, of an impression-roller cooperating with the carrier, a reciprocating paper-carrying frame arranged to draw the sheet to be printed between the stencil and the impression-roller, means for oscillating the stencil-carrier, and connections between the stencil-carrier and the paper-carrying frame, substantially as set forth.

3. In a stencil-printing machine, the combination with an oscillating stencil-carrier, of an impression-roller cooperating with the carrier, a reciprocating paper-carrying frame arranged to draw the sheet to be printed between the stencil and the impression-roller, means for oscillating the stencil-carrier, connections between the stencil-carrier and the paper-carrying frame, and means for adjusting the stencil-carrier relatively to the paper-carrying frame, substantially as set forth.

4. In a stencil-printing machine, the combination with an oscillating stencil-carrier, of an impression-roller cooperating with the carrier, a reciprocating paper-carrying frame arranged to draw the sheet to be printed between the stencil and the impression-roller, a rack on said frame, and a toothed disk carried by the stencil-carrier and engaging said rack, substantially as set forth.

5. In a stencil-printing machine, the combination with an oscillating stencil-carrier, of an impression-roller cooperating with the carrier, a reciprocating paper-carrying frame arranged to draw the sheet to be printed between the stencil and the impression-roller, a rack on said frame, a toothed disk carried by the stencil-carrier and engaging said rack, and means for elevating the stencil-carrier to disengage the disk and rack to permit relative movement of the carrier and said paper-carrying frame, substantially as set forth.

6. In a stencil-printing machine, the combination with an oscillating stencil-carrier, of an impression-roller cooperating therewith and arranged to press the sheet into contact with the stencil during the movement of the stencil in one direction and to be withdrawn from the stencil during the reverse movement, substantially as set forth.

7. In a stencil-printing machine, the combination of an oscillating stencil-carrier, a paper-carrying frame cooperating therewith, and an

impression-roller arranged to press the sheet into contact with the stencil during the movement of the stencil in one direction and to be withdrawn during the reverse movement, substantially as set forth.

8. In a stencil-printing machine, the combination of an oscillating stencil-carrier, a paper-carrying frame cooperating therewith, an impression-roller arranged to press the sheet into contact with the stencil during the movement of the stencil in one direction and to be withdrawn during the reverse movement, and grippers for engaging the sheet near the completion of the reverse movement of the stencil, substantially as set forth.

9. In a stencil-printing machine, the combination of an oscillating stencil-carrier, a paper-carrying frame cooperating therewith, an impression-roller, and cams carried by the paper-carrying frame for moving the impression-roller out of engagement with the stencil near the completion of the forward and backward strokes of the paper-carrying frame, substantially as set forth.

10. In a stencil-printing machine, the combination of an oscillating stencil-carrier, a paper-carrying frame cooperating therewith, an impression-roller, cams carried by the paper-carrying frame for moving the impression-roller out of engagement with the stencil near the completion of the forward and backward strokes of the paper-carrying frame, and a lock for holding the impression-roller in its withdrawn position during the negative stroke of said frame, substantially as set forth.

11. In a stencil-printing machine, the combination of an oscillating stencil-carrier, a paper-carrying frame, an impression-roller moved toward and away from the stencil by cams on said frame, and springs for engaging the impression-roller elastically with the sheet to be printed to force said sheet into

contact with the stencil, substantially as set forth.

12. In a stencil-printing machine, the combination of an oscillating stencil-carrier, a paper-carrying frame, an impression-roller moved toward and away from the stencil by cams on said frame, springs for engaging the impression-roller elastically with the sheet to be printed to force said sheet into contact with the stencil, and means for withdrawing the impression-roller positively out of engagement with the sheet, substantially as set forth.

13. In a stencil-printing machine, the combination of an oscillating stencil-carrier, a paper-carrying frame, an impression-roller moved toward and away from the stencil by cams on said frame, springs for engaging the impression-roller elastically with the sheet to be printed to force said sheet into contact with the stencil, and a rock-shaft and eccentrics for withdrawing the impression-roller positively out of engagement with the sheet, substantially as set forth.

14. In a stencil-printing machine, the combination of an oscillating stencil-carrier, a reciprocating paper-carrying frame cooperating therewith, limiting-fingers against which the sheet to be printed is placed, grippers carried by the reciprocating frame for engaging the sheet to draw it into engagement with the stencil, and means for withdrawing the limiting-fingers simultaneously with the engagement of the grippers, substantially as set forth.

This specification signed and witnessed this 27th day of May, 1899.

ALBERT B. DICK.

Witnesses:

ARCHIBALD G. REESE,  
JNO. R. TAYLOR.