

L. ATHERTON & O. MEEK.
 CARDING MACHINE.
 APPLICATION FILED MAY 31, 1918.

1,299,105.

Patented Apr. 1, 1919.

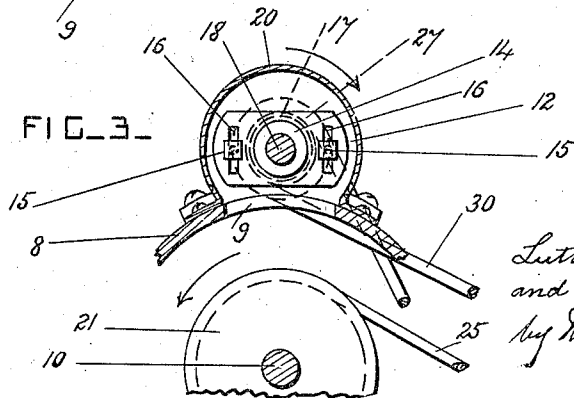
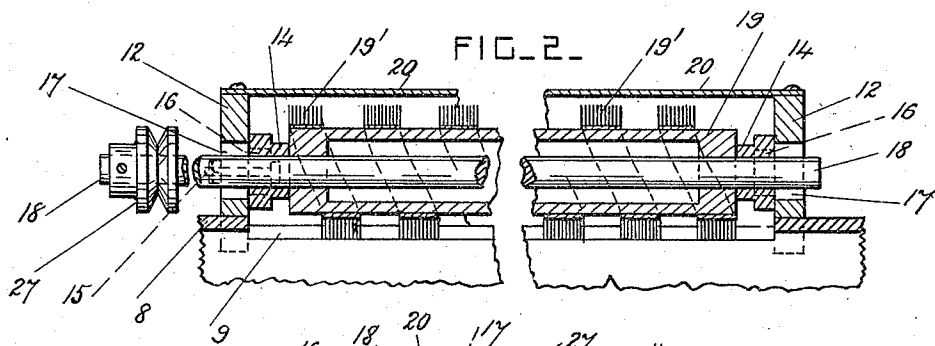
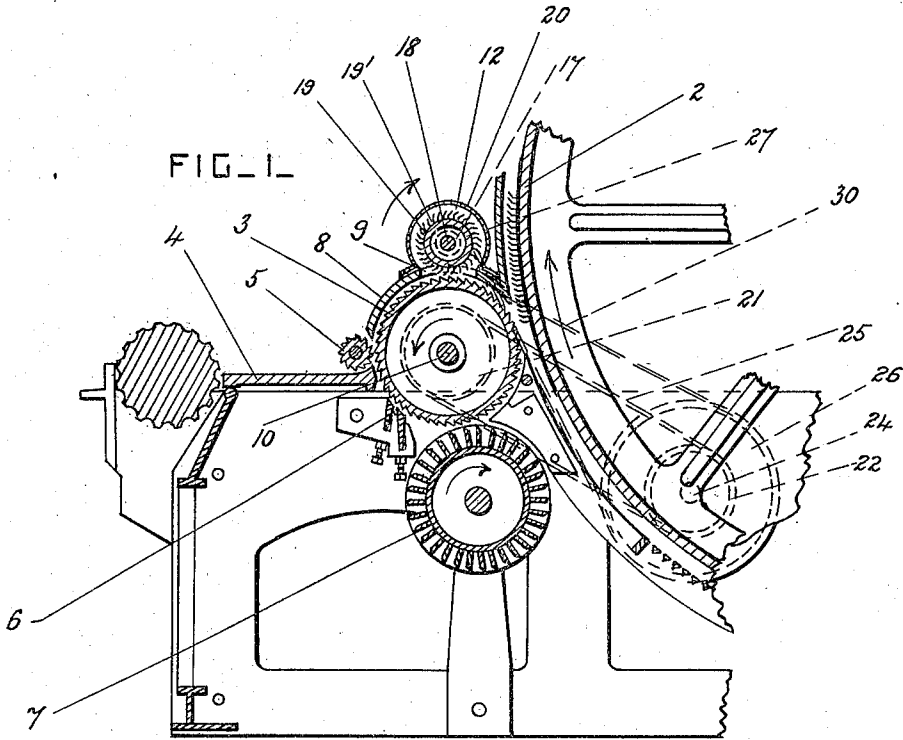

Inventors.
 Luther Atherton
 and Oscar Meek
 by *Herbert W. Jenner*
 Attorney.

UNITED STATES PATENT OFFICE.

LUTHER ATHERTON AND OSCAR MEEK, OF TALLASSEE, ALABAMA.

CARDING-MACHINE.

1,299,105.

Specification of Letters Patent.

Patented Apr. 1, 1919.

Application filed May 31, 1918. Serial No. 237,433.

To all whom it may concern:

Be it known that we, LUTHER ATHERTON and OSCAR MEEK, citizens of the United States, residing at Tallassee, in the county of Elmore and State of Alabama, have invented certain new and useful Improvements in Carding-Machines, of which the following is a specification.

This invention relates to carding machines for cotton and other similar material; and it consists of a cleaning roll constructed as hereinafter fully described and claimed and applied to the licker-in and operating to increase the production of the machine and lengthen the wearing life of the licker-in, card cylinder and other co-acting parts.

In the drawings, Figure 1 is a longitudinal section through a portion of a carding machine constructed according to this invention. Fig. 2 is a longitudinal section of a portion of the cleaning roll. Fig. 3 is a side view of the devices for driving the cleaning roll, showing the shafts in cross-section.

The card cylinder 2 of the machine is of any approved construction, and it is provided with a revoluble licker-in 3. A feed table 4 is also provided, and a revoluble feed roll 5 is arranged adjacent to the licker-in, above the feed table. Stationary mote knives 6 are arranged under the licker-in and adjacent to the feed table, and rotary mote knives 7 are arranged under the licker-in, between the stationary mote knives and the card cylinder. The various revolving parts are driven in the direction of the curved arrows in the drawings by any approved driving mechanism which is not a part of the present invention. The construction and operation of the above parts is not novel, and is not hereinafter claimed.

The licker-in is provided with a stationary housing 8 secured to the frame of the machine and extending over the upper side of the licker-in, and a longitudinal slot 9 is formed in this housing above the licker-in shaft 10. Brackets 12 are secured to the housing at the ends of this slot 9, and 14 are bearings which are secured to the brackets 12 by bolts 15. The bearings 14 have slots 16 which are slidable over the bolts 15 so that the distance between the axis of the bearings and the axis of the licker-in shaft can be adjusted. The openings 17 in the brackets are made of larger diameter than the holes of the bearings and are concentric with them. A shaft 18 is journaled in the

bearings 14, and 19 is a cleaning roll secured on the shaft 18, and provided at its periphery with a spirally wound strip of fancy fillet 19', or other approved carding or cleaning device. The spaces between the coils of the fillet are preferably of the same width as the fillet. This cleaning roll projects through the slot 9 in the licker-in housing, and it is revolved at about three times the speed of the licker-in, and in the reverse direction. A light metallic cover 20 is secured to the housing and to the brackets 12, and extends over the cleaning roll.

A driving sheave 21 is secured on the licker-in shaft, and a similar sheave 22 of the same diameter is mounted on a countershaft or pin 24 secured to the frame of the machine at a suitable distance from the licker-in shaft. A straight drive cord 25 passes over the two sheaves 21 and 22, and a driving sheave 26 is secured to the sheave 22 so that it revolves with it. The sheave 26 is preferably larger in diameter than the sheave 22, and a sheave 27 is secured on the shaft of the cleaner roll and is preferably about one-third the diameter of the sheave 26. A crossed cord 30 passes over the sheaves 26 and 27 so that the cleaner roll is revolved in the opposite direction from the licker-in.

The arrangement of the sheaves and the length of the driving cords permits of the adjustment of the cleaner roll with respect to the licker-in. The cleaner roll operates to keep the licker-in from lapping up and getting hot. When the licker-in gets hot it takes the temper out of the wires of the carding cylinder, and by the use of this cleaner roll, when properly adjusted, the working life of the licker-in and of the carding cylinder is greatly increased.

What we claim is:

1. The combination, with a carding cylinder, and a licker-in; of a stationary housing secured over the licker-in and provided with a longitudinal slot, stationary brackets secured to the housing at the ends of the said slot, bearings secured to the said brackets and adjustable with respect to the licker-in, a cleaning roll provided with a shaft which is journaled in the said bearings, said cleaning roll having at its periphery wire fancy fillet and projecting through the slot in the licker-in housing and engaging with the licker-in, a stationary cover secured to the said brackets and around the slot in the

housing and inclosing the cleaning roll, and means for revolving the cleaner roll in the reverse direction to the licker-in.

5 2. The combination, with a carding cylinder, and a licker-in; of a stationary housing secured over the licker-in and provided with a longitudinal slot, stationary brackets secured to the housing at the ends of the said slot, bearings secured to the said brackets and adjustable with respect to the licker-in, 10 a cleaning roll provided with a shaft which is journaled in the said bearings, a stationary cover secured to the said brackets and around the slot in the housing and inclosing the cleaning roll, said cleaning roll having at its 15 periphery wire fancy fillet and projecting through the slot in the licker-in housing and engaging with the licker-in, driving wheels secured to the licker-in and to the cleaner roll respectively, two driving wheels secured together and mounted on a countershaft or

pin, and flexible driving connections passing over the said wheels and operating to drive the cleaner roll in the reverse direction from the licker-in and to permit the adjustment 25 of the cleaner roll.

3. The combination, with a carding cylinder, a licker-in, and mote knife devices arranged below the licker-in; of a stationary housing secured over the licker-in and provided with a longitudinal slot, stationary brackets secured to the housing at the ends of the slot, a stationary cover arranged over the said slot and secured to the said brackets, an adjustable cleaning roll arranged under 35 the said cover and above the licker-in and projecting through the said slot, and means for revolving the cleaner roll.

In testimony whereof we affix our signatures.

LUTHER ATHERTON.
OSCAR MEEK.

Copies of this patent may be obtained for five cents each, by addressing the "Commissioner of Patents, Washington, D. C."