



US00D962139S

(12) **United States Design Patent**  
**Wu**

(10) **Patent No.:** **US D962,139 S**

(45) **Date of Patent:** **\*\* Aug. 30, 2022**

(54) **AUTOMOTIVE INSTRUMENT PANEL**

(71) Applicant: **Advanced Development Depot, Inc.**  
Rancho Cucamonga, CA (US)

(72) Inventor: **Chuan-Hsing Wu**, Rancho Cucamonga,  
CA (US)

(\*\*) Term: **15 Years**

(21) Appl. No.: **29/678,525**

(22) Filed: **Jan. 29, 2019**

(51) **LOC (13) Cl.** ..... **12-16**

(52) **U.S. Cl.**

USPC ..... **D12/192**

(58) **Field of Classification Search**

USPC ..... D12/192, 415, 114, 345; D15/17, 28;  
D10/46, 98, 102-103, 122-127; D23/324  
CPC ..... B60H 1/34; B60H 1/3407; B60H 1/3414;  
B60H 1/3421; B60H 1/3428; B60H  
1/3435; B60H 1/3442; B60H 1/345;  
B60H 1/3457; B60H 2001/3464; B60H  
2001/3471; B60H 2001/3478; B60H  
2001/3485

See application file for complete search history.

(56) **References Cited**

**U.S. PATENT DOCUMENTS**

D848,918 S \* 5/2019 Hisada ..... D12/192  
D871,285 S \* 12/2019 Witt ..... D12/192

D895,499 S \* 9/2020 Park ..... D12/192  
D905,607 S \* 12/2020 Ahn ..... D12/192  
D906,208 S \* 12/2020 Ahn ..... D12/192  
D915,254 S \* 4/2021 Bray ..... D12/192  
D915,257 S \* 4/2021 Dellemann ..... D12/192  
D915,963 S \* 4/2021 Park ..... D12/192  
D915,965 S \* 4/2021 Ahn ..... D12/192  
D915,966 S \* 4/2021 Ahn ..... D12/192  
D921,548 S \* 6/2021 Franganillo ..... D12/192  
D922,283 S \* 6/2021 Park ..... D12/192  
D933,556 S \* 10/2021 Witham ..... D12/192

\* cited by examiner

*Primary Examiner* — Katrina A Betton

(74) *Attorney, Agent, or Firm* — Tsz Lung Yeung

(57) **CLAIM**

The ornamental design for an automotive instrument panel,  
as shown and described.

**DESCRIPTION**

FIG. 1 is a front view of an automotive instrument panel  
showing a first embodiment of my new design; and,  
FIG. 2 is front view of an automotive instrument panel  
showing a second embodiment of my new design.  
The broken lines in the drawings represent portions of the  
automotive instrument panel that forms no part of the  
claimed design.

**1 Claim, 2 Drawing Sheets**

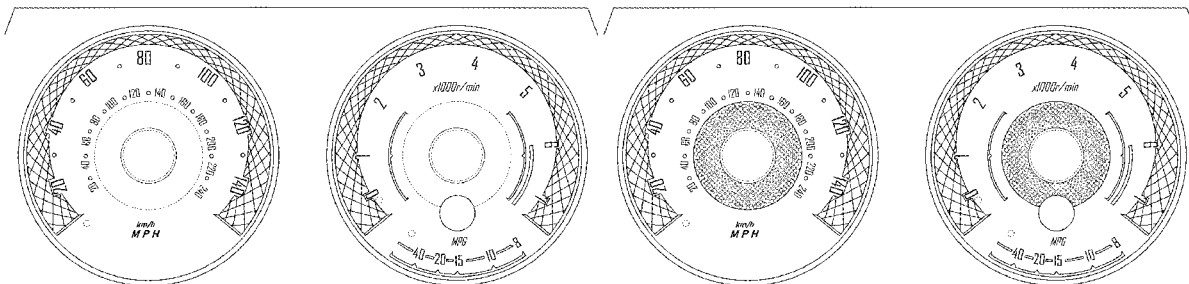

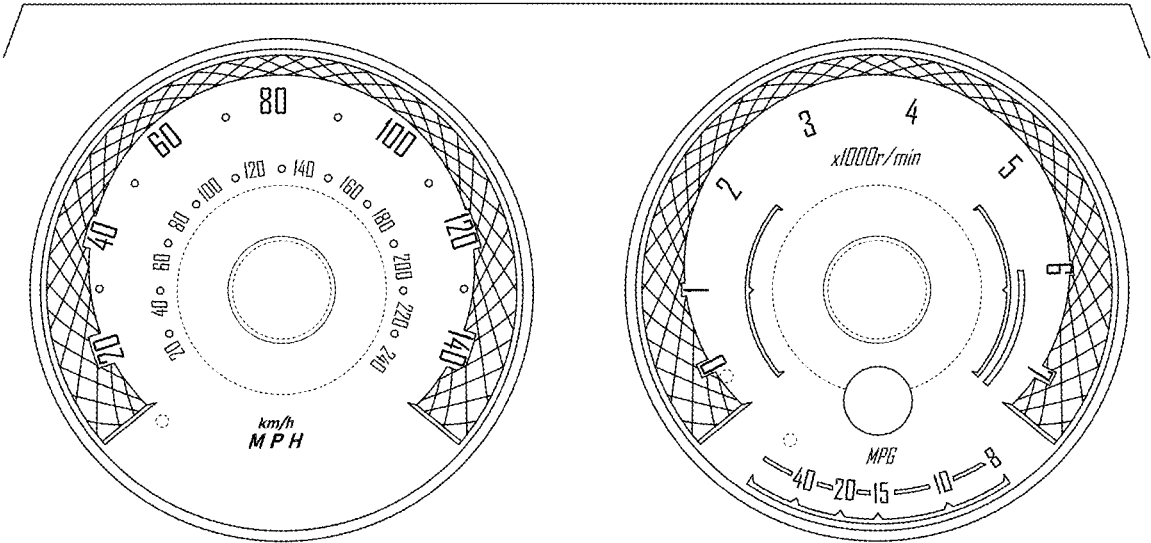

FIG.1

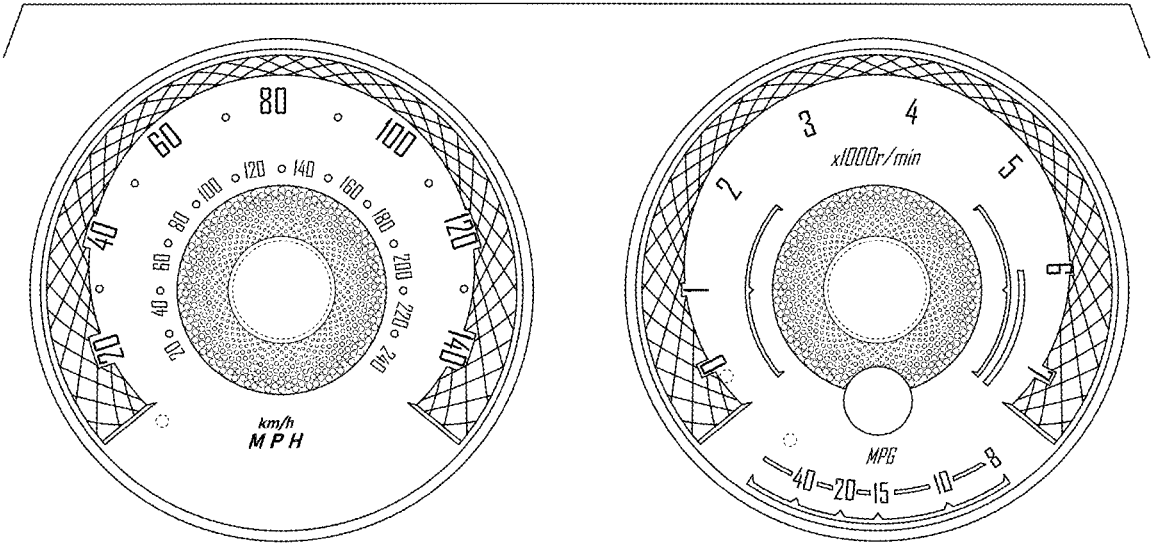

FIG.2