

(No Model.)

2 Sheets—Sheet 1.

F. SCHUMANN.  
STEAM ENGINE GOVERNOR.

No. 318,663.

Patented May 26, 1885.

Fig. 1.

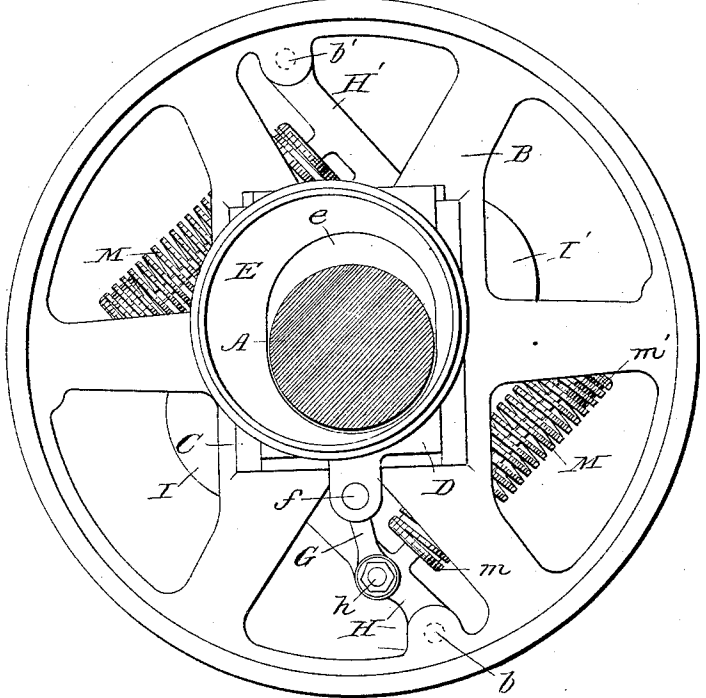
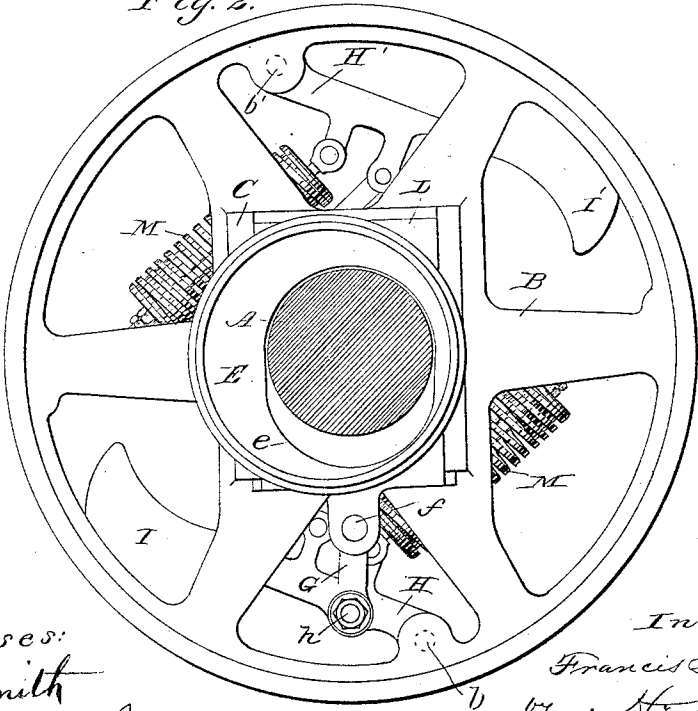

Fig. 2.



Witnesses:  
 E. D. Smith  
 J. R. Rommel

Inventor:  
 Francis Schumann  
 by A. N. Low  
 attorney.

F. SCHUMANN.  
STEAM ENGINE GOVERNOR.

No. 318,663

Patented May 26, 1885.

Fig. 3.

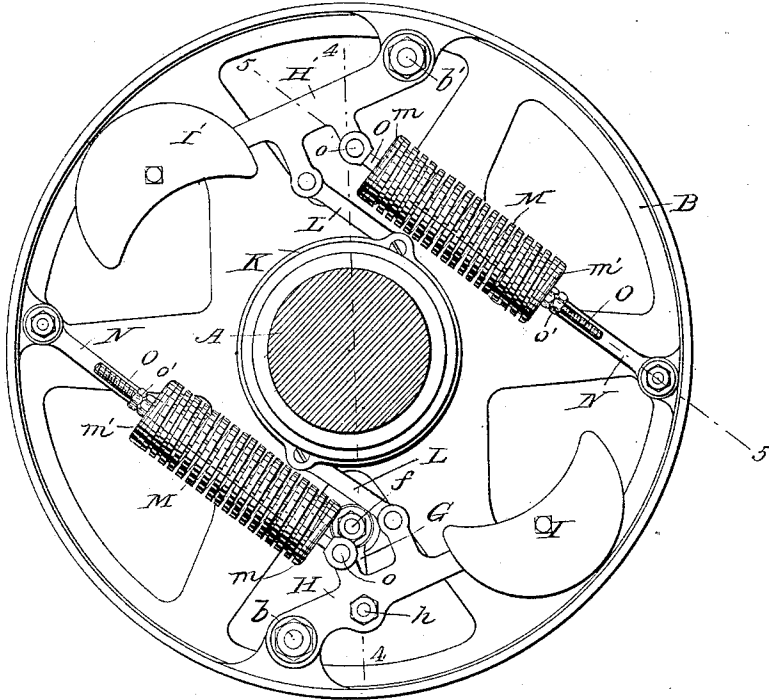

Fig. 4.

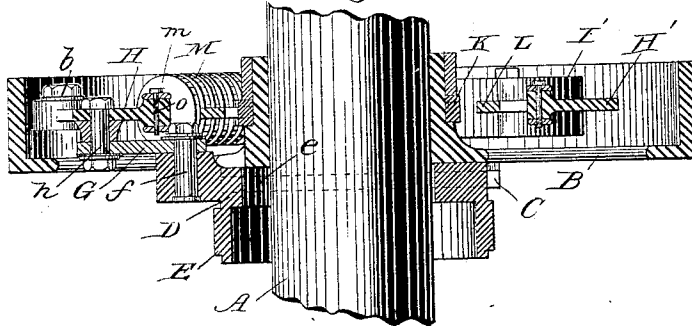
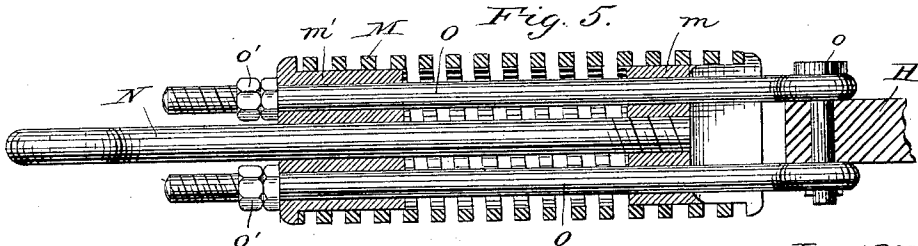

Fig. 5.



Witnesses:  
 E. D. Smith  
 J. H. Connet, Jr.

Inventor:  
 Francis Schumann,  
 by N. N. Low,  
 attorney.

# UNITED STATES PATENT OFFICE.

FRANCIS SCHUMANN, OF TRENTON, NEW JERSEY, ASSIGNOR OF ONE-HALF  
TO W. D. HAVEN, OF SAME PLACE.

## STEAM-ENGINE GOVERNOR.

SPECIFICATION forming part of Letters Patent No. 318,663, dated May 26, 1885.

Application filed January 31, 1885. (No model.)

*To all whom it may concern:*

Be it known that I, FRANCIS SCHUMANN, a citizen of the United States, residing at Trenton, in the county of Mercer and State of New Jersey, have invented certain new and useful Improvements in Steam-Engine Governors; and I do declare the following to be a full, clear, and exact description of the invention, such as will enable others skilled in the art to which it appertains to make and use the same.

My invention relates to that class of steam-engine governors in which the centrifugal force of weights carried by a rotating shaft of the engine operates to shift the valve-eccentric relative to the crank-shaft, and thus regulate the admission of steam to the cylinder.

It relates more particularly to governors of said class in which the eccentric is rotated partially to regulate the lead of the valve, and also moved so as to bring its center nearer to or farther from the center of its shaft to diminish or increase the valve's travel.

In order to make my invention more clearly understood, I have shown in the accompanying drawings a method of carrying it into effect.

Figure 1 is a side elevation of a governor embodying my invention, the centrifugal weights being in the position they occupy when the engine is at rest. Fig. 2 is a similar view, the weights being shown in their outermost position and the eccentric correspondingly shifted. Fig. 3 is an elevation from the opposite side of the governor, the parts being in the same position as in Fig. 2. Fig. 4 is a sectional view on line 4 4, Fig. 3. Fig. 5 is a section on line 5 5, Fig. 3, showing the manner of supporting the controlling-springs.

A represents a shaft, preferably the main crank-shaft of the engine, upon which is keyed or otherwise securely fastened the disk, plate, or wheel B. Upon the latter are cast or bolted ways C, adapted to receive and guide in its reciprocation a slide, D. The eccentric E is made integral with or rigidly secured to the slide D. The slide and eccentric have an opening or slot, *e*, parallel to the ways C, through which the shaft A passes, and which is of such length as to permit of the reciprocation of said slide and eccentric transversely to the shaft. The slot *e* is at one side of the eccentric E, and

extends at an angle to those radii of the eccentric in which lie the points of greatest and least eccentricity. The result of this arrangement is that, as the eccentric is reciprocated transversely to the shaft and the latter occupies different positions in the slot, both the degree of eccentricity, and consequently the travel, of the valve is changed, and also the position relative to the piston-crank of the radii of greatest and least eccentricity, which correspondingly regulates the lead of the valve.

I am aware that a sliding eccentric of the above description is not new; but I am not aware that it has been combined with a rectilinear slide and a link through which it may be reciprocated positively in either direction by a weighted and spring-controlled lever or levers.

A link of the character referred to is shown at G, pivoted at *f* to the slide D, and at *h* to a lever, H. The lever is fulcrumed at *b* to the wheel B, and carries at its free end a weight, I, which furnishes, when the shaft and wheel are rotated, the centrifugal force necessary for operating the governor. The lever and weight H I are balanced and their action supplemented by a lever and weight, H' I', fulcrumed at *b'*, and arranged symmetrically opposite to the first-mentioned lever and weight. The operation of the two levers and weights is equalized and rendered simultaneous by a collar, K, and links L L, in a well-known manner.

As is usual with this class of governors, the centrifugal tendency of the weighted levers is opposed by springs, the force of which may be regulated so that it shall be equal to the centrifugal force of the levers when the engine is at the desired speed. I do not claim such construction of springs, broadly; but in the arrangement of the springs and their bearings I have devised certain improvements whereby a more sensitive and efficient action of the governor is attained. Heretofore tension-springs have generally been used, and when compression-springs have been employed it has been found difficult to arrange their seats or bearings so that the resistance to the springs shall be in the line of their axes. To so arrange their seats has an important effect in keeping the springs in line and preventing

their buckling outward, and in getting a uniformly increased and reliable degree of resistance from the springs as they are compressed. I have effected this by pivoting each seat of the spring so that it may turn as the spring changes position and always be in line therewith. I have also combined with said seats a projection or boss of the same diameter as the interior of the spring and extending for some distance into said interior to maintain the springs in line.

M M are spiral compression-springs of the character above described. They are held between and tend to force apart the bearings or seats  $m m'$ . The bearings  $m$  are connected with the wheel B by means of rods N, pivoted to the wheel at  $n$ , and the bearings  $m'$  are each connected with one of the levers H by rods O, pivoted to the levers at  $o$ . The latter rods are shown as being adjustable in their seats  $n'$  by jam-nuts  $o'$ , by which the resistance of the springs may be regulated.

Preferably the rods N and O pass from the seats to which they are secured through the springs M and through the opposite seats to the points where said rods are pivoted. They thus furnish guides upon which the seats may travel, and thus keep the springs in place.

When the spring is mounted, as shown, between the seats  $m m'$ , held together by the rods O and N, it may readily be handled and placed in or removed from its place in the governor without inconvenience or danger from its powerful resistance.

By suspending the compression-spring between two points of attachment beyond the opposite ends of the spring it is not liable to be swung out of position by centrifugal force, as is the case where both points of attachment to the lever and to the wheel B are at the same end of the spring.

I am aware that heretofore a plate carrying an eccentric has been suspended upon links and oscillated by toggles at each end, which in turn were operated by weighted levers having link-connections with the toggle-joint, as shown in Patent No. 269,678 to A. Kendall, December 26, 1882. I do not claim any combination of elements found in such construction. For my present purpose, in constructing a simple, easily-regulated, well-balanced, and sensitive governor, I deem such arrangement disadvantageous. In the oscillation of the plate upon its supporting-links and guide-pins there is a disturbing element of motion, as well as a looseness, which renders the rectilinear slides C much preferable. Also, on account of the action of the toggles, the weights in the construction referred to necessarily move unequal distances. The weights, therefore, cannot be made to move simultaneously or to keep each the same distance as the other from the center of revolution. This throws the governor out of balance, practically making one side of it heavier than the other, seriously impairing the sensitiveness and efficiency of its action. With said arrangement of

toggles it is impossible to combine the equalizing collar and links K L L.

I do not claim my particular arrangement of springs, broadly, but as applied to a steam-governor and under the conditions specified.

I am aware that such an arrangement has been heretofore used in draw-bars for cars.

Having thus described my invention, what I claim, and desire to secure by Letters Patent of the United States, is—

1. In a steam-engine governor, the combination of a shaft, a plate secured thereto having ways C, a slide mounted on said plate to reciprocate transversely to the shaft, an eccentric carried by the slide and having a slot parallel with the lines of reciprocation and at an angle to the line of greatest and least eccentricity, a weighted lever pivoted to the plate, a spring for opposing the centrifugal tendency of the lever, and a link connecting the lever directly to the slide, substantially as set forth.

2. In a steam-engine governor, the combination of a shaft, a plate secured thereto having ways C, a slide mounted on said plate to reciprocate transversely to the shaft, an eccentric carried by the slide, a weighted lever pivoted to the plate, a spring connected with the plate and bearing on the lever for opposing its centrifugal tendency, and a link connected directly with the lever and pivoted to the slide substantially in line with its center of gravity, as set forth.

3. In a steam-engine governor, the combination of a shaft, a plate secured thereto, a slide mounted on said plate to reciprocate transversely to the shaft, an eccentric carried by the slide, two weighted levers on opposite sides of the shaft and pivoted to the plate, a collar and links for connecting and equalizing the force of the levers, springs for opposing their centrifugal force, and a link for connecting one of the levers to the slide, substantially as set forth.

4. In a steam-engine governor, the combination of a shaft, a plate secured thereto, an eccentric surrounding the shaft, a weighted lever or levers pivoted to the plate and connected with the eccentric to shift the same, and a spiral compression spring or springs held between two bearings or seats, one seat being connected pivotally with the plate and the other being connected pivotally with the lever, said seats having cylindrical bosses extending into and fitting the interior of said springs, substantially as set forth.

5. In a steam-engine governor, the combination of a shaft, a plate secured thereto, an eccentric surrounding the shaft, weighted levers fulcrumed on said plate and connected with the eccentric to shift the same, and spiral compression-springs suspended between seats connected with points of attachment on the plate and levers, each seat being suspended from that point which is at the opposite end of the spring, substantially as set forth.

6. In a steam-engine governor, the combi-

nation of a shaft, a plate secured thereto, an eccentric surrounding the shaft, a weighted lever or levers fulcrumed to the plate and connected with the eccentric, a spiral compression spring or springs, bearings for the ends of the same, and rods secured to one bearing engaging with the opposite bearing and passing thence to points of attachment on the lever and plate, substantially as set forth.

10 7. In a steam-engine governor, the combination, with a shifting eccentric and weighted centrifugal arms, of a device for controlling the

weighted arms, consisting of a spiral compression-spring, M, seats *m m'* at each end thereof, and rods N and O, each secured to one of the seats and passing through the opposite seat to the point of attachment of the rods, substantially as set forth. 15

In testimony whereof I affix my signature in presence of two witnesses.

FRANCIS SCHUMANN.

Witnesses:

WM. O'REILLY,

J. JACOB STEPHENS.