

W. C. MCGILL.

Combination Locks.

No. 136,606.

Patented March 11, 1873.

Fig. 1.

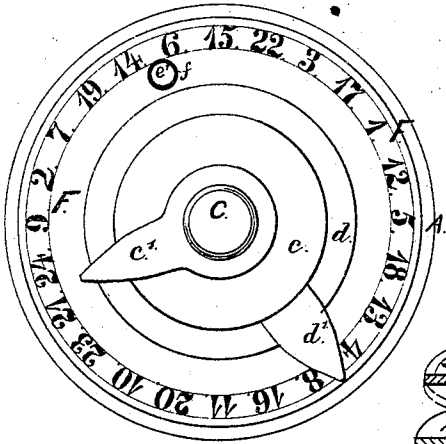
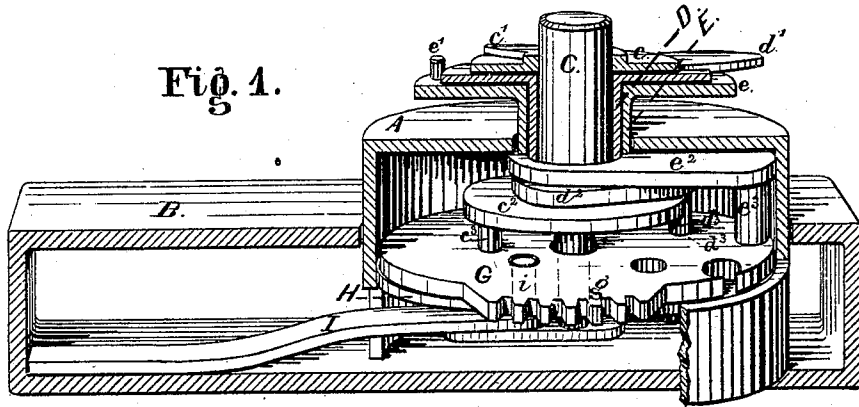
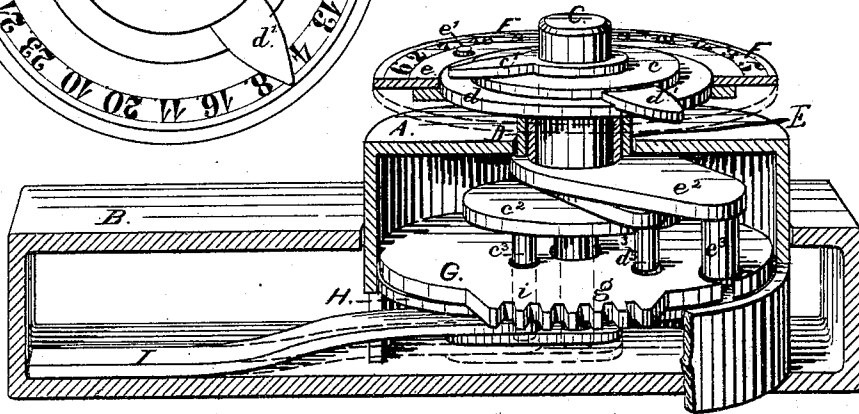

Fig. 2.



Attest.

J. B. Corbin
J. Van Kannel

Inventor.

W. C. McGill

UNITED STATES PATENT OFFICE.

WILLIAM C. MCGILL, OF CINCINNATI, OHIO.

IMPROVEMENT IN COMBINATION LOCKS.

Specification forming part of Letters Patent No. 136,606, dated March 11, 1873.

To all whom it may concern:

Be it known that I, WILLIAM C. MCGILL, of Cincinnati, county of Hamilton and State of Ohio, have invented a new and Improved Combination Lock; and I do hereby declare that the following is a full, clear, and exact description of the same, reference being had to the annexed drawing making a part of this specification, in which—

Figure 1 is a vertical cross-section, in perspective, representing the lock unlocked and the combination broken. Fig. 2 is a similar view, showing the same locked with the combination made.

Similar letters of reference indicate like parts.

The nature of my invention relates to what is known as a permutation or combination lock. It consists of a series of tumblers rotating around a vertical shaft, said tumblers terminating above in hands over a movable dial, and below in cranks or disks provided each with a pin, which enters corresponding holes in a segmental gear-disk which operates the bolt.

The construction of my invention is as follows: The cylindrical shell or casing A is attached to the body or frame B, as may be found most convenient for attaching the same to objects to be locked. Through the center of said shell is let a vertical shaft, C, and over the same a tube, D, and over the latter another tube, E. The shaft C terminates above and outside the lock in a small disk, c , and hand c^1 ; below it receives a disk or crank, c^2 , and pin c^3 . The tube D terminates above in disk d and hand d^1 ; below it receives a disk, d^2 , and pin d^3 . The tube E terminates above in disk e , provided with a small projection, e^1 , for receiving the dial-plate; below it terminates in disk e^2 and pin e^3 .

The shaft C and tubes D and E rotate freely forward or backward with the parts attached to them, respectively.

F is the movable dial-ring, graduated and marked as indicated in the drawing. The hole f in dial receives the pin e^1 of disk E. G is a segmental gear-disk, which operates the bolt by the intervention of a rack in the usual way. H is a permanent bottom, on which rests the disk G, and is perforated to receive the locking-pin of spring I. The spring I is provided with pin i , which, passing through the hole in bottom H, enters the segmental gear-disk G when the same is locked.

The lower end of shaft O also touches the spring I when the former is depressed.

The operation of my invention is as follows: The combination being broken and the bolt engaged, the dial-plate is placed in position and a given figure on the dial is brought opposite a fixed point on the lock, after which hands c^1 and d^1 are turned to their respective figures on the dial. This brings pins c^3 , d^3 , and e^3 directly over the three holes in disk G. Upon pressing the dial-plate the three pins enter the three holes, pushing the spring I downward by the end of shaft C coming in contact with said spring, as well as one of the pins c^3 , d^3 , or e^3 pressing on the pin i . This obviously disengages the lock-spring I from the disk G. The dial in its depressed position may now be turned together with disk G, and by the segment of gear g on disk G, which is constantly engaged with a rack on the bolt, moves the bolt forward or backward, thus locking or unlocking it at pleasure.

It will be observed that the pin i passes through the permanent bottom H, and is at no time pushed entirely out of it, and the said pin i invariably re-enters the disk G when the hole in the disk is brought opposite and the dial released. When the bolt has been moved forward in the locked position the pin i enters the disk G by the spring moving up, and pins c^3 , d^3 , e^3 may then be moved in different positions, breaking the combination. The dial-plate may then be removed, whereby no one even acquainted with the combination can open the lock.

When it is desired to change the combination it is only necessary to procure a new plate with figures differently arranged, or the same arrangement with the hole in the dial at a different point.

The combination may also be changed by turning the hands on the shaft C and tubes D and E when so desired.

Having thus described my invention, what I claim as new, and desire to secure by Letters Patent, is—

The arrangement of the shaft C with the tubes or sleeves D and E, provided with their respective pins c^3 , d^3 , and e^3 , in combination with gear-disk G, as and for the purpose herein described.

WM. C. MCGILL.

Attest:

T. VAN KANNEL,
J. B. CORBIN.