

G. H. GRIFFITHS.  
Improvement in Velocipedes.

No. 130,712.

Patented Aug. 20, 1872.

Fig:2

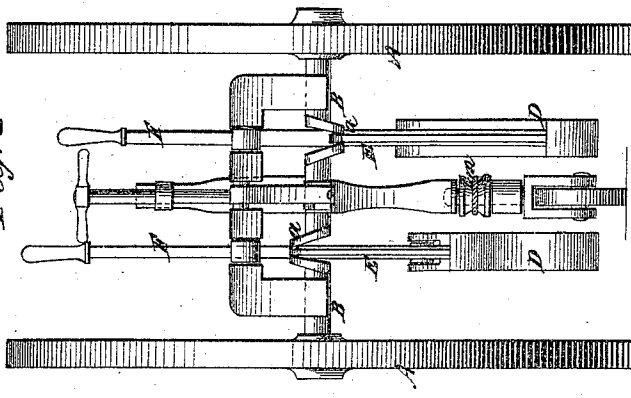

Fig:1

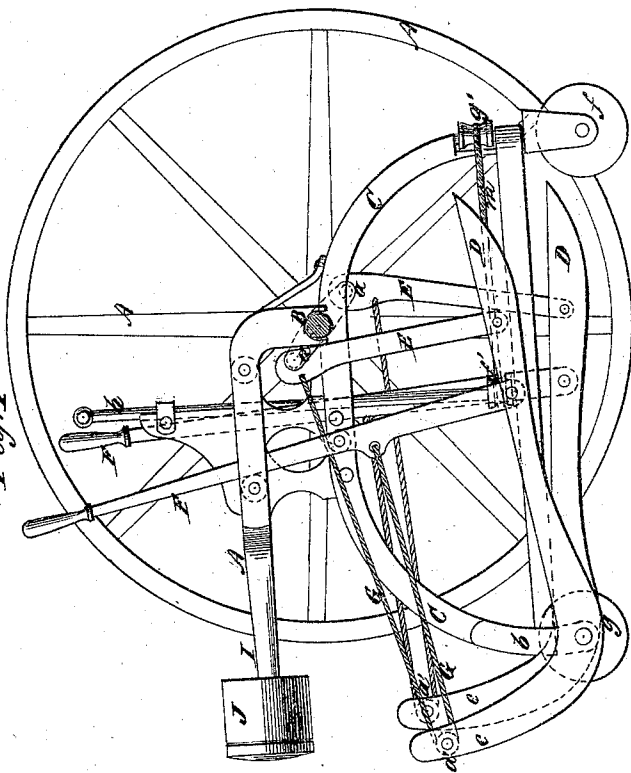
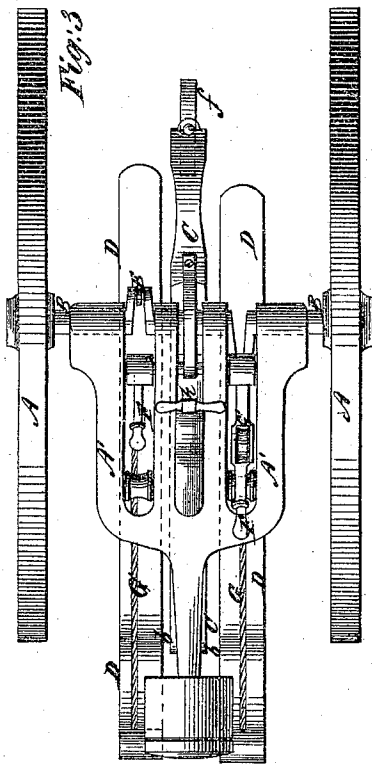

Fig:3



Witnesses:  
Fred Haynes  
Fred Busch

G. H. Griffiths  
per Bennett Allen

@Hornsey

# UNITED STATES PATENT OFFICE.

GEORGE HENRY GRIFFITHS, OF NEW YORK, N. Y.

## IMPROVEMENT IN VELOCIPEDES.

Specification forming part of Letters Patent No. 130,712, dated August 20, 1872.

Specification describing certain Improvements in Combined Hand and Foot Power for Propelling Velocipedes and for other purposes, invented by GEORGE H. GRIFFITHS, of the city, county, and State of New York.

This invention is more especially designed for the propulsion of velocipedes, but one feature thereof may be employed for driving rotary shafting for any appropriate machinery. The invention consists in so combining a double crank-shaft, two treadles, and two hand-levers with suitable connecting devices that, while a treading or walking movement of the feet applied to the treadles transfers force for rotary motion to the crank-shaft, the hand-levers, acting alternately with the treadles, will throw the cranks past their dead-centers, and thereby insure the continuous motion of the shaft. The invention also consists in the combination with the wheeled frame carrying the propelling mechanism, just above specified, when the same is used with or upon a velocipede, of a counterbalance weight, whereby the weight of the rider may be so balanced or adjusted that the velocipede may, to all intents and purposes, run upon its two supporting-wheels without and from the usual third wheel or caster.

Figure 1 is a side view of an apparatus constructed according to my invention. Fig. 2 is an end view of the same looking from the rear. Fig. 3 is a plan view of the same.

A A are the two main or supporting wheels of the machine—one of them fast and the other loose upon the ends of the shaft or axle B—this latter formed with two cranks, *a*, extending in opposite directions. Centrally suspended from the axle is a frame, C, to the forward end *b*, and at either side of which is pivoted a treadle, D. Each treadle is connected by a rod, E, with one of the cranks *a*, and, furthermore, has its forward end extended to form an arm, *c*, in which is a pulley, *a*. In each treadle, forward of the point at which the rod E is attached thereto, is pivoted the lower end of a lever, F, which extends up past the top frame A, (this last sustained by suitable bearings upon the shaft or axle B,) in such position as to be readily grasped by the hands of the rider or operator standing upon the treadles D. In each of the levers is a slot fitted for the recep-

tion of a pulley, *c'*. From a point in each lever below the pulley *c* extends a cord, band, or chain, G, forward over the pulley *a* in the arm *c* of the treadle, to which said lever is attached, and thence back over the pulley *c'* in the lever to the upper end of the rod E connecting with the crank *a*. At one end of the frame C is a small wheel, *f*, which serves merely to keep such end of the frame from the ground when the machine is left unbalanced by the weight of the rider as when not in use. At the opposite extremity of the aforesaid frame is a steering-wheel, *g*, working on a vertical arbor, and receiving motion from the steering-shaft or helm *h* by means of a cross-belt, *m*, extending from a pulley, *f*, on the steering-shaft, to another, *g'*, on the arbor. Upon the forward end of the top frame A is a horizontal bar, I, upon which is placed an adjustable counter-weight, J.

In using the apparatus, the operator takes his stand upon the treadles D with each hand grasping one of the levers F, and, with the counter-weight adjusted to balance his own weight, swings clear from the ground and is brought wholly dependent from the axle. On depressing one of the treadles with a movement of the foot similar to that of walking, one of the cranks *a* is pulled backward and downward. Simultaneously with the inception of the movement of the treadle the lever F, connected with the other or opposite treadle, is pulled back, and, acting through the cord or chain G, pulls forward the other crank *a*, which, extending in a direction opposite to that of the one acted upon by the treadle, is caused to exert an axial movement upon the shaft B in the same direction, and thereby throws past the dead-point the crank upon which the treadle is acting, and thus insures the facile and efficient operation of the treadle upon its crank. As soon as one treadle is depressed in this manner the weight of the operator thrown upon the other foot depresses the other treadle in like manner, the crank of the latter being thrown past the dead-point by the backward movement of the lever previously inoperative. A continuous rotary motion is thus given to the shaft or axle B, which, being transmitted to the wheel fast thereon, insures the propulsion of the vehicle, or, in case the shaft or axle

is fitted in fixed bearings, the transmission of motion to any machinery suitably applied in connection therewith.

It will furthermore be seen that the weight of the operator, instead of being partially supported by a seat, as in ordinary treadle movements, is sustained wholly by the treadles, from one to the other of which it is thrown alternately, the crank of one lever being thrown, at each start of the downward stroke of the treadle, past its dead-point by the action of the lever connected with the other treadle.

The treadles it will be observed, aside from their fixed fulcrums, are acted upon at three points—viz., those at which the rods E, the levers F, and the cords G are attached thereto—and the apparatus virtually constitutes a walking-machine, in which a motion on the part of the operator equivalent to that of walking produces a forward motion of much

greater speed than with the same exertion would be secured by ordinary pedestrianism.

What I claim as my invention is—

1. The combination of the treadles D, rods E, levers F, and cords or chains G with the double-cranked axle B furnished with the depending frame C, the whole arranged and operating substantially as herein set forth, for the purpose specified.

2. The combination of the adjustable counterbalance weight J with the wheeled frame carrying and capable of propulsion by the mechanism comprising the treadles D, levers F, double-cranked axle B and their connecting devices, substantially as and for the purpose herein set forth.

GEORGE HENRY GRIFFITHS.

Witnesses:

FRED. HAYNES,  
FERD. TUSCH.