

(19)



(11)

**EP 1 600 560 B1**

(12)

**EUROPEAN PATENT SPECIFICATION**

(45) Date of publication and mention of the grant of the patent:  
**16.12.2009 Bulletin 2009/51**

(51) Int Cl.:  
**E02D 3/12 (2006.01)**

(21) Application number: **04447134.0**

(22) Date of filing: **28.05.2004**

(54) **A method and device for forming a pile**

Verfahren und Apparat zur Herstellung eines Pfahls

Procédé et dispositif pour réaliser un pieu de fondation

(84) Designated Contracting States:  
**AT BE BG CH CY CZ DE DK EE ES FI FR GB GR HU IE IT LI LU MC NL PL PT RO SE SI SK TR**

(56) References cited:  
**EP-A- 1 045 073 DE-A- 3 831 547**  
**DE-A1- 10 216 952**

(43) Date of publication of application:  
**30.11.2005 Bulletin 2005/48**

- **PATENT ABSTRACTS OF JAPAN vol. 2000, no. 13, 5 February 2001 (2001-02-05) & JP 2000 273864 A (NKK CORP), 3 October 2000 (2000-10-03)**
- **PATENT ABSTRACTS OF JAPAN vol. 2003, no. 12, 5 December 2003 (2003-12-05) & JP 2004 137670 A (GEOTOP CORP; ASO FOAM CRETE CO LTD), 13 May 2004 (2004-05-13)**
- **PATENT ABSTRACTS OF JAPAN vol. 1997, no. 07, 31 July 1997 (1997-07-31) & JP 9 060463 A (IKEDA HIROSHI), 4 March 1997 (1997-03-04)**

(73) Proprietor: **Smet F & C**  
**2480 Dessel (BE)**

(72) Inventor: **Smet, Dirk**  
**2480 Dessel (BE)**

(74) Representative: **Brouwer, Hendrik Rogier et al**  
**Gevers & Vander Haeghen,**  
**Holidaystraat 5**  
**1831 Diegem (BE)**

**EP 1 600 560 B1**

Note: Within nine months of the publication of the mention of the grant of the European patent in the European Patent Bulletin, any person may give notice to the European Patent Office of opposition to that patent, in accordance with the Implementing Regulations. Notice of opposition shall not be deemed to have been filed until the opposition fee has been paid. (Art. 99(1) European Patent Convention).

## Description

**[0001]** The invention relates to a method of forming a mixed pile in subsoil layers, comprising drilling a hole into the soil layers, loosening the soil inside the bore hole, and mixing said soil with a binding agent to stabilize it and form the mixed pile. The invention also relates to a device for performing the method.

**[0002]** A known method of forming a mixed pile in subsoil layers is described in DE-A-10216952. In DE-A-10216952, a method is disclosed wherein a hole is formed in the subsoil layers by introducing an assembly of a tube and a rotationally driven mixing member into the subsoil layers. The mixing member in the form of a shaft extends substantially inside of and coaxially with said tube and is provided with a plurality of mixing blades, arranged along its longitudinal direction. During introduction into the subsoil, the rotating mixing member loosens up the soil inside the tube by the action of the mixing blades and removes said soil by transporting it to the surface. A hardenable binding agent is brought into the bored hole and mixed with the loosened soil by rotating the mixing member inside the tube. After thorough mixing of the binding agent and soil, the assembly is removed from the subsoil by pulling it upward. As a result of the known method, a mixed pile is formed in the subsoil layers, consisting of a hardened mixture of soil and binding agent. A plurality of mixed piles thus formed can for instance be used as foundation for aboveground constructions, to stabilize soils in general and/or to form an earth-retaining wall.

**[0003]** Although the known method provides for suitable mixed piles, a huge amount of soil has to be removed from the subsoil and transported to the surface during the manufacture of the mixed pile. Moreover the mixing of hardenable binding agent and the soil inside the tube by rotating the mixing member is not efficient. As a result a large amount of binding agent has to be used in order to obtain the necessary structural rigidity for the mixed pile.

**[0004]** JP 2000 273864 A describes a method for forming a mixed pile in subsoil layers comprising introduction of a prefabricated hollow pile body into the ground. The hollow pile body is provided with blades at the tip and is removably fitted at its barrel section to a rotating/intruding device. By arranging an auger in the Pile body and by rotating the Pile body and the auger, the ground near the tip of the Pile body is softened and excavated. From the tip of the auger a binding agent is sprayed which is stirred and mixed with the excavated and softened sediment while the Pile body is intruded and left into the ground. Thereafter, the auger is retracted from the Pile body.

**[0005]** JP 2004 137670 A discloses a method for introducing a hollow prefabricated pile into the ground by passing a rod of an excavator through the inside of a hollow prefabricated pile. While the ground is excavated by an excavating and stirring mechanism provided at the tip of the rod, a solidifier is injected in the hollow pile, and

the excavated sediment and the solidifier are stirred and mixed. Simultaneously, the prefabricated pile is submerged to a desired depth. The prefabricated pile is then left into the ground and the rod is retracted.

5 **[0006]** EP-A-1045073 discloses a method for forming a column of consolidated soil by introducing an excavating tool into the ground, the excavating tool having a tubular central shaft with a vertical axis and a central axial opening for supplying a soil-consolidating fluid through  
10 nozzle means. EP-A-1045073 further discloses to inject high-pressure jets of binding agent in downward direction for fluidising and at least partially breaking up the soil before it is engaged by the blade element in its excavation movement. Inclined nozzles can be provided near the  
15 shaft for injecting pressurized jets directed outwardly and additional nozzles can be provided on the shaft injecting pressurized jets directed radially outwards for further fluidising and breaking down the excavation material.

**[0007]** JP09060463 describes a method for forming a column of solidifying material slurred with the displaced  
20 or drilled soil in subsoil layers by drilling a hole in the soil. The hole is formed by introducing a drilling assembly comprising a hollow pile surrounding a mixing member comprising stirring blades. The solidifying material is injected into the soil and mixed with the soil by the mixing  
25 blades.

**[0008]** DE3831547 describes a method for forming a mixed pile in subsoil layers comprising drilling a hole into the subsoil layers by loosening the soil and mixing the  
30 subsoil layers inside the bore hole with a binding agent to stabilize the soil and form the mixed pile. The hole is formed by introducing a mixing member into the subsoil layers while the binding agent is injected under a pressure of about 40 bar.

35 **[0009]** It is the aim of the present invention to provide a method of forming a mixed pile in subsoil layers, comprising drilling a hole into the soil layers, loosening the soil inside the bore hole, and mixing said soil with a binding agent to stabilize it and form the mixed pile, whereby  
40 a limited amount of soil has to be removed during the manufacture of the mixed pile, and a limited amount of binding agent has to be supplied in order to obtain the necessary structural rigidity for the mixed pile.

**[0010]** This aim and further advantages described below are obtained by a method according to claim 1. In particular, the method according to the invention is **characterized in that** a fluid is injected into the soil to be stabilized by high-pressure jets, in view of loosening and cutting the subsoil layers while adding the binding agent  
45 to the loosened materials of the subsoil layers, in that the whole is mixed by means of the mechanical action of the blades and by turbulence created by the high-pressure jets and in that the tube and the mixing member are rotated in opposite directions while the drilling assembly is  
50 inserted into the subsoil layers.

**[0011]** By loosening the soil substantially inside the tube through the action of high-pressure jets, a much improved mixing efficiency of binder and soil is achieved.

The high-pressure jets effectively cut the soil inside the tube into small particles. These small particles are easily mixed with the hardenable binding agent to form a pile with the necessary rigidity after hardening out the mixture of soil and binder. As a result of the action of the high-pressure jets, applicant has surprisingly found that much less soil needs to be transported to the surface by the mixing member. Also it turned out that substantially less binding agent is necessary to obtain a pile with comparable structural rigidity as that of the pile, obtained by the known method.

**[0012]** The method according to the invention can be applied in any soil material. It is for instance possible to use the method in silt, clay and/or organic materials, in sand, sandstone, gravel, masonry and reinforced or unreinforced concrete materials, and/or allied materials.

**[0013]** A field in which the method of the invention is applied, is inter alia producing stable foundation layers in said soil layers consisting of silt or technically equivalent materials. A further field of application is making such ground layers, banks etc. resistant to all forms of erosion. Another field of application is providing earth-retaining and/or water retaining walls, or underground walls able to retard the seeping in of groundwater.

**[0014]** The method of the invention is preferably used in soils which contain layers of hard material, such as for instance rock and/or the remains of formations of old foundation elements. Because the method according to the invention employs a tube around the mixing member, the assembly of mixing member and tube effectively cuts through such layers of hard material, instead of being branched off by them. Also, the use of a tube makes it possible to provide mixed piles with a well defined, predetermined diameter. This allows to construct earth- and/or groundwater-retaining walls with much improved retaining capability, since it is now possible to accurately dimension the adjacent mixed piles, thus preventing accidental slits or openings between them.

**[0015]** According to the method of the invention, high-pressure jets are used to loosen up the earth masses, eventually in combination with mechanical means provided by the mixing blades of the mixing member. Compared to the known method, the use of high-pressure jets to loosen up the soil (substantially) between mixing member and tube, and to mix said soil and binding agent entails several advantages: a) the required mechanical moment to rotate the mixing member during drilling into the ground is lower, which considerably reduces the required rotary power of the bore head; b) the supporting structures of the device used to perform the method of the invention can be executed comparatively lighter, which improves manoeuvrability of the device; and c) the wear rate of knives and mixing blades on the mixing member and possibly on the tube is much reduced since the cutting forces which in the normal method are very substantial, are lower.

**[0016]** A characteristic feature of the method according to the invention is the use of a fluid to be injected at

high pressure, which fluid readily allows to cut said soil materials, thereby disrupting the soil structure, allows to at least partly dislodge the disrupted particles, and finally allows to bind the soil particles again into a novel solid soil structure. Said fluid is preferably injected in accordance with a rotary pattern, whereby turbulences are created in order to better homogenize the soil and fluid materials.

**[0017]** When applying the known method it frequently happens that large pieces of soil materials are entrained by the mixing blades of the mixing member. These pieces may interfere with the rotating action of the mixing member, or may inhibit the transport to the surface of the excavated soil material. An additional advantage of the method and device according to the invention is that the soil materials are effectively cut into small pieces, thus preventing such phenomenon.

**[0018]** According to a preferred embodiment of the method of the invention, the hardenable binding agent is added to the loosened soil species in counter flow to the abovementioned rotary pattern.

**[0019]** In accordance with a further preferred embodiment said hardenable binding agent is injected into the soil species by means of the high-pressure jets.

**[0020]** In accordance with a still further preferred embodiment of the method the hardenable binding agent is simultaneously injected at a high pressure by means of said high-pressure jets and the binding agent is also injected at a, preferably lower pressure at any arbitrary angle to the loosened materials. In given circumstances it can be useful to provide also an injection of binding agent together with the high-pressure injection. This variant and further variants of the method are proof of its high degree of flexibility.

**[0021]** Suitable binding agents for use in the method of the invention may for instance be selected from cement, bentonite, fly ash, lime, mortar, and derived cement types (known by the person skilled in the art as "blends") such as for instance Dämmmer, gels, polymers, sand, flint chips and/or shingle, or a combination of said materials.

**[0022]** The method in accordance with the invention and the device derived there from render it possible to process soil layers of widely different types to the desired depth, with the object to introduce mixed piles or foundations therein. The essential difference with the techniques which have been used in the art up till now resides in the fact that the soil material which has to be part of a formed mixed pile is cut, partly dislodged and partly mixed by injecting a fluid at a high pressure into the soil layers to be processed.

**[0023]** High pressure must in the context of the present application be understood to mean a pressure between 5 and 1000 bar, more preferably between 200 and 800 bar, most preferably between 350 and 500 bar. The fluid to be injected at high pressure is preferably water or air, or more preferably a combination of both of them. To the fluid a hardenable binding agent is preferably added.

**[0024]** Adopting a mixture of hardenable binding agent

with either air and/or water as fluid to be injected, allows to inject the binding agent into the soil materials while simultaneously cutting and loosening up the soil materials. The injection of the fluid at a high pressure is preferably performed in accordance with a rotary pattern. (Part) of the binding agent is then preferably added, if necessary at a lower pressure in counter flow to the high-pressure injection. Adding (part) of the binding agent can also be effected, preferably also at a lower pressure, in the same (rotational) direction as the high-pressure injection.

**[0025]** One of the most striking features of the method and the device of the invention is therefore that by primarily using the cutting force of the fluid injected at a high pressure, there must be no fear for rapid wear of cutting tools, and/or mixing blades. In addition, it will also be readily appreciated that the method shows great flexibility since the high and/or lower pressure at which fluid and/or binding agent are injected into the soil can be varied at will, dependent on for instance soil structure and characteristics. The fluid may, according to the invention be injected over the entire length of the mixing member. In a preferred embodiment of the method the mixing member extends further downward into the soil layers than the surrounding tube, and is moreover provided with injection apertures in this lower part of the mixing member. Hence, fluid is freely - not retained by the tube wall - injected into the soil layers over a radial distance which is larger than the diameter of the tube. The area influenced by the fluid injected at a high pressure can be adapted to the needs at any moment by selecting the pressure level. This embodiment is particularly useful when constructing a water impermeable wall of mixed piles. Indeed the method according to the invention readily allows to construct adjacent mixed piles which partly overlap, since the use of the tube allows to partly bore into an already formed mixed pile. In this way a plurality of piles may be formed which partly overlap and thereby form a water seepage retarding or water retaining wall. By injecting fluid with hardenable binding agent under high pressure radially outward from underneath the tube, a thorough mixing between an already formed mixed pile and a following - still to be formed pile - is obtained. This further improves the water retaining capability of the plurality of adjacently formed mixed piles.

**[0026]** The invention also relates to a device for putting the method in accordance with the invention into effect, according to claim 11. Further details of the device and method of the invention will be apparent from the following description of a preferred embodiment of the device. This description is only given by way of example and does not imply that the invention is limited in any way to the example. The reference numbers relate to the accompanying figures.

**[0027]** Figure 1 is a schematic overview of the device and method in accordance with the present invention.

**[0028]** Figure 2 is a schematic view of a typical lower mixing blade (the rotary head) of the mixing member of

the device in accordance with the invention.

**[0029]** Figures 3 - 6 are schematic representations of several possible mixed pile patterns.

**[0030]** Figure 7 is a detailed schematic view of part of the mixing member and tube.

**[0031]** The device illustrated by these figures was developed to render possible given works, as described in the opening paragraph of the present specification. A device which excellently satisfies the object aimed at, is shown in Figure 1. The device comprises a supporting structure 1 which may be manipulated by for instance a caterpillar vehicle 2 (also known in the art as a drilling rig). Obviously any other manipulating structure, such as for instance a crane, may be used instead. On the supporting structure 1, a double bore head 3 is attached. This double bore head 3 comprises two rotary driving engines 3a and 3b. Rotary engine 3b is able to rotationally drive a tube 5, while rotary engine 3a is able to rotationally drive mixing member 4. Rotary engines 3a and 3b may form a combined unit or may be two separate units. Also, rotary engines 3a and 3b may be translatable - together or apart - along the supporting structure 1 along its longitudinal direction. Mixing member 4 and tube 5 are supported such that they extend substantially coaxially to each other, whereby mixing member 4 can be translated into tube 5. It is also possible to provide the mixing member 4 with a telescopic rod, thereby enabling to push mixing member 4 into the soil at a depth below the depth of the underside of tube 5. Mixing member 4 thereby protrudes further into the soil than tube 5. In the method according to the invention rotary driving engines 3a and 3b drive the mixing member 4 and tube 5 in opposite directions when drilling into the soil layers. By adopting opposite rotational directions for mixing member 4 and tube 5 during drilling into the ground, the torsion forces experienced by the double bore head 3, and by the whole device, are substantially reduced during the drilling operation. Also, when hitting a subsoil layer with substantial hardness, the assembly of mixing member 4 and tube 5 does not easily branch off. The lower end of the mixing member 4 (the end which protrudes first into the soil when drilling the hole) is formed by a shaft 11 which can be caused to rotate together with the rest of the mixing member, or of which, if so required, only the head, i.e. its lower portion, is capable of independent rotation. The bottom part of the shaft 11 is provided with at least one blade 12, which is intended for injecting a fluid at a high pressure. The apertures through which this fluid is injected at a high or a very high pressure are denoted by reference numerals 13. The arrows 14 indicate a possible direction in which the shaft 11 with blades 12 rotates. Two further elements 15 having apertures 13' are preferably attached to the blades 12.

**[0032]** In an embodiment according to the invention the binding agent to be mixed with the loosened soil may be added at a lower pressure (up to a maximum of preferably 50 bar) and is then mainly effected through apertures 13' in a direction opposite to the direction of rotation

of the blades 12, which are primarily provided for cutting open the soil mass to be processed. The binding agent is consequently in this embodiment of the invention fed into a mass which has already been cut open and homogenized by injecting a fluid at a high pressure.

**[0033]** In the figures added to the description, the blades 12 and the coupling elements 15 coupled thereto are represented as being of a tubular shape. Tubular blades 12 and associated tubular elements 15 offer great advantages from a constructional point of view since the blades thus formed and elements connected thereto are excellent means for guiding the fluid employed together with the binding agent. This guidance can for instance also be accomplished by separate pipelines, extending inside of the tubular elements.

**[0034]** It is self-understood that the supply lines or feed pipes for the fluid and/or binding agent run through the mixing member over its entire length. Easy flow of fluid and/or hardenable binder can also be provided by using a hollow mixing member 4. In a completely different embodiment the blades 12 may be formed by steel sections or small beams on which the required pipelines for injecting fluid and binding agent are fastened.

**[0035]** The structure of said blades 12 is determined by their various functions. These functions can in essence be summarized as follows: a) cutting and mixing soil masses; b) injecting over adjustable distances various binding agent compositions; c) accommodating or supporting the pipelines for fluid and binding agents; d) constituting if so required the lines mentioned sub c).

**[0036]** The length of the blades 12 taken in the direction from the wall of the rotary head depends of course on the objective. In practice the overall length of the blades is between approximately 0,30m and 5 m, of course dependent on the diameter of the tube 5 used in the method, and the desired diameter of the mixed pile to be formed. Preferably the overall length of the blades is between approximately 0,40 m and 1,20 m.

**[0037]** As shown in Figure 7, the blades 12 and/or 15 may be provided with mechanical cutting devices 24, to further aid ingress of the mixing member 4 into the soil layers.

**[0038]** From a constructional point of view, as is shown in Figure 2, a reinforcement means 16 may be provided at the tip of the mixing member 4. This reinforcement means 16 may be of any shape and does not form a characterizing feature of the invention. The shaft 11 and mixing member 4, can rotate in two directions and at different speeds. It can also be moved up and down and this likewise at different speeds. The mixing member 4 and shaft 11 itself can be utilized as a tube in which the fluid feed-through channels can be incorporated. The shaft 11 itself can drive the blades but it will be obvious that the blades with the rotary head of the device may form a separate component part thereof.

**[0039]** Although in the application reference is made in several places to a rotary head, the technical equivalent thereof is a shaft which rotates through its overall

length. The choice of the suitable device does in no way detract from the principle of the invention.

**[0040]** Relative to the soil surface the mixing member 4, with optionally shaft 11, can be set at any angle by supporting member 1, which may be manipulated from a lifting platform or pontoon or from the landward side when the device is part of, for example, a vehicle.

**[0041]** Mixing member 4 preferably is provided at its lowest end with a conically shaped protrusion for easy penetration into the soil layers. Moreover, mixing member 4 preferably is provided with apertures 6 for injecting fluid and/or hardenable binder under high pressure. These apertures 6 may be spaced along the longitudinal direction of the mixing member 4 over its entire length.

It is even more preferred to provide the mixing blades 8 of mixing member 4 with apertures 7, which may be in the form of nozzles, adjustable with respect to the direction of injection of the fluid and/or hardenable binder. To obtain the desired homogeneous mixing of soil particles and binder, apertures 7 on blades 8, and apertures 13, 13' on blades 12 and associated tubular elements 15 are preferably arranged along the radial direction of mixing blades 8 and 12, and associated tubular elements 15. The radial direction is defined with respect to the longitudinal axis of the mixing member 4. More preferred this radial arrangement is such that the distance between following apertures becomes larger for apertures closer to the central axis of the mixing member 4. It is possible to provide the apertures with nozzles 7, 13 which may be positioned in a specific direction.

**[0042]** Tube 5 consists essentially of a tubular structure preferably provided at its lower end with a cutting means. The cutting means may be any suitable cutting device known to the skilled person in order to aid to rotationally insert the tube into the subsoil structures. Tube 5 preferably has a substantially smooth outer surface, to be able to drive tube 5 into the soil easily. However, the circumferential wall of tube 5 may be perforated, i.e. be provided with irregularly and/or regularly spaced openings of some size. To further improve the efficiency of the method and device, the inner side of the circumferential wall of tube 5 preferably is provided with additional mechanical mixing devices 19, such as elevated wall portions pointing radially inwards, which cooperate with the blades 8 and/or the fluid jets (6, 7) of mixing member 4. These wall portions 19 may extend over at least a part of the inner surface of tube 5, but may also be in the form of pins, and the like.

**[0043]** When the soil layers must be stabilized to a given depth and a supporting structure must be erected therein or thereupon, inter alia for the subsequent erection of, for example, an embankment, operations can be effected in accordance with several patterns. Figures 3 and 4 illustrate several patterns for the mixed piles 20. According to the invention a triangular and a square grid pattern wherein a non-processed area remains between the piles 20 can easily be formed. Such patterns are for instance suitable to lay a foundation.

**[0044]** Figure 5 shows processed soil layers of the so-called wall-type in which a non-processed area remains between rows of adjacently arranged piles 21. Piles 21 have been formed by drilling the tube of the second pile partly into the already formed first pile.

**[0045]** Figure 6 illustrates soil layers which are processed over a larger area wherein a given area was "fully" processed and the plurality of piles 22 fully occupy the relevant area. As regards the pile structures shown in figures 5 and 6, it will be noted that the built-up piles 21, 22 have fused together. This is of course possible because the binding agent used and injected here will harden only progressively and several contiguous piles have in fact, and partly, fused together. This type of arrangement is particularly suitable to form a water retaining wall, and is only possible by using the device and method of the invention. Indeed the outer tube allows to predetermine the diameter of the mixed piles formed by the method.

**[0046]** Figure 7 shows by way of example a detail of the mixing member 4 provided with blades 8 and surrounded by tube 5. Mixing member 4 rotates in direction 14, while tube 5 rotates in the direction 14', opposite to direction 14. Blades 8 may be adapted to the nature of the soil into which mixing member 4 is applied. The skilled person may for instance vary the tilt angle of the blades 8 with respect to the longitudinal axis of the mixing member 4, the width and shape of the blades, the pitch of the blades, and so on. It is also possible to provide a mixing member 4 which is only over part of its surface provided with blades 8, such that the mixing member 4 is bladeless over a part of its length. It is also possible to provide the mixing member 4 with pins and other protruded parts 19 in addition to the blades 8.

**[0047]** The mixing member 4 may have a hollow core through which the binding agent which is suitable for the purpose of forming a mixed pile may be transported. Adding the binding agent can be performed in several ways: a) In the first place adding the binding agent can be effected via apertures 13' which are specially provided for this purpose and which allow the binding agent and a fluid, used as a vehicle of the binding agent, to pass at a lower pressure. Adding the binding agent at a lower pressure (up to a maximum of approximately 50 bar) is preferably performed in counter flow to the direction 14 in which the high-pressure jets 13 are active. The low pressure is sufficient to pass and distribute the fluid and the transported binding agent in the opened-up materials; b) In certain cases, and as a function of the stabilization to be performed, the binding agent can be injected together with the high-pressure jets 13, 6, 7 into the material to be processed. Since the binding agent preferably requires a fluid in order to be easily conveyable, the binding agent is injected together with the fluid at a high pressure (between approximately 5 to 1000 bar).

**[0048]** According to the invention a plurality of mixed piles are formed in subsoil layers, by first drilling a hole into the soil layers. This is done by bringing the assembly

of mixing member 4 and tube 5 in the vicinity of the location where a pile is to be formed through drilling rig 2. Drilling rig 2 then manipulates supporting structure 1 provided with mixing member 4, tube 5, bore heads 3a and 3b (or more bore heads if required) and any other additional devices such that the desired starting position is reached. In many circumstances, this position will be substantially vertical to the soil surface, although this is not required to carry out the invention. As illustrated in Figure 1a, the assembly of mixing member 4 and tube 5 is driven into the subsoil by the action of bore heads 3a and 3b. The rotational directions of mixing member 4 and tube 5 are indicated in Figure 1 as 30 and 31. By rotating tube 5 and mixing head 4 in counter rotation to each other hard subsoil layers are easily cut through. During this phase of the method according to this embodiment, the soil inside the tube 5 is loosened by the action of the blades 8 and 12, and/or by the action of the fluid injected through nozzles 6, 7, and 13 and 13'. Obviously the binding agent fluid is contained in a reservoir, which is provided with a supply line to the mixing member 4 and/or tube 5. Intimate mixing between binding agent and soil material is obtained, thereby stabilizing the soil substantially inside the tube 5, and forming the mixed pile 20, 21 and/or 22. As shown in Figure 1b, the rotational directions 30, 31 of mixing element 4 and tube 5 respectively are then reversed while preferably injecting binder. The assembly of mixing element 4 and tube 5 is hereby translated upward along supporting member 1. In this way original soil is removed from the space substantially inside the tube 5, and replaced by a soil/binder mixture (a pile thus formed is denoted as a "mixed" pile). In a third phase the formed mixed pile 20 may be reinforced further by introducing into it a suitable armament 23, such as for instance steel rods and the like. Providing the mixed pile with an additional reinforcement is optional and does not constitute a necessary requirement in the method according to the invention. Finally the mixed pile 20 is allowed to harden during a suitable period, before it will be loaded.

**[0049]** The above method may be repeated several times, thus forming a plurality of mixed piles. Possible patterns for the mixed piles are illustrated in Figures 3 - 6.

**[0050]** The invention is not limited to the embodiment described herein and many modifications may be made, in so far as these modifications are within the scope of the accompanying claims.

## Claims

1. A method of forming a mixed pile in subsoil layers by stabilizing the soil, comprising drilling a hole into the subsoil layers, loosening the soil and mixing the subsoil layers inside the bore hole with a binding agent to stabilize the soil and form the mixed pile, wherein the hole is formed by introducing a drilling assembly of a rotationally driven mixing member (4)

- and a tube (5) into the subsoil layers, said mixing member (4) extending substantially inside of and coaxially with said tube (5) and being provided with a plurality of mixing blades (8),, injecting the binding agent into the soil and mixing the soil with the binding agent by means of mechanical action of the blades (8) thus forming a subsoil mixed pile, after which the drilling assembly is extracted from the subsoil by pulling it upward, **characterized in that** a fluid is injected into the soil to be stabilized by high-pressure jets, in view of loosening and cutting the subsoil layers while adding, the binding agent to the loosened materials of the subsoil layers, **in that** the whole is mixed by means of the mechanical action of the blades (8) and by turbulence created by the high-pressure jets and **in that** the tube (5) and the mixing member (4) are rotated in opposite directions while the drilling assembly is inserted into the subsoil layers.
2. A method as claimed in claim 1, **characterized in that** said binding agent is added at a, preferably lower pressure to the soil loosened by the said high pressure jets, and in counter flow to said high-pressure jets.
  3. A method as claimed in claim 1 or 2, **characterized in that** said binding agent is injected in the soil to be loosened by employing said high-pressure jets.
  4. A method as claimed in claim 2 or 3, **characterized in that** said binding agent is simultaneously injected at a high pressure by using said high-pressure jets and, in counter flow thereto, is added at a lower pressure to the loosened materials.
  5. A method as claimed in any one of claims 1 - 3, **characterized in that** the properties of the fluid used in the high pressure jets are such as to readily allow to cut said soil materials, thereby disrupting the soil structure, allow to at least partly dislodge the disrupted particles, and finally allow to bind the soil particles again into a novel solid soil structure, and that said fluid is injected in accordance with a rotary pattern, whereby turbulences are created in order to better homogenize the soil and fluid materials.
  6. A method as claimed in any one of claims 1 - 5, **characterized in that** said soil materials are loosened by employing high pressure jets at a pressure of between 5 and 1000 bar.
  7. A method as claimed in claim 2 or 4, **characterized in that** said lower pressure is selected between 1 bar and 50 bar.
  8. A method as claimed in any one of claims 1 - 7, **characterized in that** the fluid used in the high pressure jets comprises water and/or air.
  9. A method as claimed in claim 8, **characterized in that** said binding agent is injected together with said fluid.
  10. A method as claimed in any one of claims 1 - 9, **characterized in that** the binding agent comprises at least one of cement, bentonite, fly ash, lime, polymers, mortar, derived cement types, gels, or a combination thereof.
  11. A device for forming a mixed pile in subsoil layers comprising a drilling assembly of a tube (5) and a mixing member (4), which drilling assembly can be manipulated by the action of a manipulating device (1) and bored into the subsoil by the action of a bore head (3), the bore head (3) comprising two rotary driving engines (**3a, 3b**), **namely a** rotary engine (3b) being able to rotationally drive the tube (5) and **a** rotary engine (3a) being able to rotationally drive the mixing member (4), which mixing member (4) extends substantially inside of and coaxially with said tube (5) and is provided with a plurality of mixing blades (8), the device comprising means for injecting a binding agent into the subsoil layers, the manipulating device comprising means for **pulling** upward and removing the drilling assembly (4, 5) from the subsoil after formation of the mixed pile in the subsoil layers, **characterized in that** the mixing member (4) contains at least over part of its surface a plurality of apertures (13) through which a fluid can be injected under high pressure into the soil and **in that** the tube (5) and the mixing member (4) are adapted to be rotated in opposite directions while the drilling assembly is inserted into the subsoil layers.
  12. A device according to claim 11, **characterized in that** the apertures (13) are located on the mixing blades (8).
  13. A device according to claim 11 or 12, **characterized in that** the apertures (13) are located predominantly at the lower end of the mixing member (4).
  14. A device according to claim 13, **characterized in that**, the mixing member (4) at least at its lower end is provided with a rotary head (10) equipped with blades (12) for on the one hand injecting under pressure a fluid for loosening the materials, and on the other hand for adding at a lower pressure in counter flow thereto a binding agent to the loosened materials.
  15. A device as claimed in claim 14, **characterized in that** blades (12) have an overall length of between approximately 0,3 and approximately 5 m.
  16. A device as claimed in claim 14 or 15, **characterized in that** blades (12) are of a tubular shape and have

apertures (13) for injecting at a high pressure a fluid and/or a binding agent.

17. A device as claimed in claims 14 -or 15, **characterized in that** blades (12) are constituted by sections to which pipelines for injecting a fluid at a high and/or at a low pressure, and/or a binding agent, are attached.
18. A device as claimed in any one of claims 14 -16, **characterized in that** connected to each of tubular blades (12) there is a tubular element (15) for injecting through apertures (13') a fluid with a binding agent at a lower pressure and in counter flow to the high-pressure injection.
19. A device as claimed in any one of claims 14 -18, **characterized in that** said rotary head (10) is provided with reinforcing means (16).
20. A device as claimed in any one of claims 11 - 19, **characterised in that** the tube (5) is provided **at its lower end** with a cutting means.

#### Patentansprüche

1. Verfahren zum Herstellen eines Mischpfahles in Untergrundschichten durch Stabilisieren des Bodens, umfassend das Bohren eines Lochs in die Untergrundschichten, das Lockern des Bodens und das Mischen der Untergrundschichten innerhalb des Bohrloches mit einem Bindemittel, um den Boden zu stabilisieren und den Mischpfahl herzustellen, wobei das Loch durch Einführen einer Bohrgarnitur aus einem drehend angetriebenen Mischglied (4) und einem Rohr (5) in die Untergrundschichten hergestellt wird, wobei sich das Mischglied (4) im Wesentlichen innerhalb des und koaxial zu dem Rohr (5) erstreckt und mit mehreren Mischschaufeln (8) versehen ist, das Injizieren des Bindemittels in den Boden und das Vermischen des Bodens mit dem Bindemittel durch die mechanische Wirkung der Schaufeln (8), wodurch ein Untergrund-Mischpfahl hergestellt wird, woraufhin die Bohrgarnitur durch Emporziehen derselben aus dem Untergrund entfernt wird, **dadurch gekennzeichnet, dass** ein Fluid durch Hochdruckdüsen in den zu stabilisierenden Boden injiziert wird, um die Untergrundschichten zu lockern und zu durchschneiden, während den gelockerten Materialien der Untergrundschichten das Bindemittel zugesetzt wird, dass das Ganze mittels der mechanischen Wirkung der Schaufeln (8) und durch von den Hochdruckdüsen erzeugte Turbulenz vermischt wird und dass, während die Bohrgarnitur in die Untergrundschichten eingeführt wird, das Rohr (5) und das Mischglied (4) in entgegengesetzte Richtungen gedreht werden.
2. Verfahren nach Anspruch 1, **dadurch gekennzeichnet, dass** das Bindemittel dem Boden, der durch die Hochdruckdüsen gelockert wird, vorzugsweise mit einem niedrigeren Druck und im Gegenstrom zu den Hochdruckdüsen zugesetzt wird.
3. Verfahren nach Anspruch 1 oder 2, **dadurch gekennzeichnet, dass** das Bindemittel durch Verwendung der Hochdruckdüsen in den zu lockernden Boden injiziert wird.
4. Verfahren nach Anspruch 2 oder 3, **dadurch gekennzeichnet, dass** das Bindemittel gleichzeitig durch Verwendung der Hochdruckdüsen mit einem hohen Druck injiziert wird und im Gegenstrom dazu den gelockerten Materialien mit einem niedrigeren Druck zugesetzt wird.
5. Verfahren nach einem beliebigen der Ansprüche 1-3, **dadurch gekennzeichnet, dass** die Eigenschaften des in den Hochdruckdüsen verwendeten Fluids derart sind, dass sie ohne Weiteres ermöglichen, die Bodenmaterialien zu durchschneiden, wodurch die Bodenstruktur zertrennt wird, ermöglichen, die zertrennten Stückchen mindestens zum Teil zu verlagern, und schließlich ermöglichen, die Bodenstückchen wieder in eine neue feste Bodenstruktur zu binden, und dass das Fluid gemäß einem Rotationsmuster injiziert wird, wodurch Turbulenzen erzeugt werden, um die Boden- und die Fluidmaterialien besser zu homogenisieren.
6. Verfahren nach einem beliebigen der Ansprüche 1-5, **dadurch gekennzeichnet, dass** die Bodenmaterialien durch Verwenden von Hochdruckdüsen mit einem Druck zwischen 5 und 1000 bar gelockert werden.
7. Verfahren nach Anspruch 2 oder 4, **dadurch gekennzeichnet, dass** der untere Druck zwischen 1 bar und 50 bar gewählt wird.
8. Verfahren nach einem beliebigen der Ansprüche 1-7, **dadurch gekennzeichnet, dass** das in den Hochdruckdüsen verwendete Fluid Wasser und/oder Luft umfasst.
9. Verfahren nach Anspruch 8, **dadurch gekennzeichnet, dass** das Bindemittel gemeinsam mit dem Fluid injiziert wird.
10. Verfahren nach einem beliebigen der Ansprüche 1-9, **dadurch gekennzeichnet, dass** das Bindemittel mindestens eines aus der Gruppe umfassend Zement, Bentonit, Flugasche, Kalk, Polymere, Mörtel, Zementderivattypen, Gele oder eine Kombination daraus umfasst.

11. Vorrichtung zum Herstellen eines Mischpfahls in Untergrundsichten, umfassend eine Bohrgarnitur aus einem Rohr (5) und einem Mischglied (4), wobei die Bohrgarnitur durch die Wirkung einer Betätigungsvorrichtung (1) betätigt und durch die Wirkung eines Bohrkopfes (3) in den Untergrund gebohrt werden kann, wobei der Bohrkopf (3) zwei Rotationsantriebsmotoren (3a, 3b), und zwar einen Rotationsmotor (3b), der in der Lage ist, das Rohr (5) drehend anzutreiben, und einen Rotationsmotor (3a), der in der Lage ist, das Mischglied (4) drehend anzutreiben, umfasst, wobei sich das Mischglied (4) im Wesentlichen innerhalb des und koaxial zu dem Rohr (5) erstreckt und mit mehreren Mischschaufeln (8) versehen ist, wobei die Vorrichtung Mittel zum Injizieren eines Bindemittels in die Untergrundsichten umfasst, wobei die Betätigungsvorrichtung Mittel zum Emporziehen und Entfernen der Bohrgarnitur (4, 5) aus dem Untergrund nach dem Herstellen des Mischpfahls in den Untergrundsichten umfasst, **dadurch gekennzeichnet, dass** das Mischglied (4) mindestens über einen Teil seiner Oberfläche mehrere Öffnungen (13) aufweist, durch welche ein Fluid unter Hochdruck in den Boden injiziert werden kann, und **dadurch**, dass das Rohr (5) und das Mischglied (4) ausgebildet sind, um, während die Bohrgarnitur in die Untergrundsichten eingeführt wird, in entgegengesetzte Richtungen gedreht zu werden.
12. Vorrichtung nach Anspruch 11, **dadurch gekennzeichnet, dass** die Öffnungen (13) an den Mischschaufeln (8) angeordnet sind.
13. Vorrichtung nach Anspruch 11 oder 12, **dadurch gekennzeichnet, dass** die Öffnungen (13) überwiegend an dem unteren Ende des Mischglieds (4) angeordnet sind.
14. Vorrichtung nach Anspruch 13, **dadurch gekennzeichnet, dass** das Mischglied (4) mindestens an seinem unteren Ende mit einem Rotationskopf (10) versehen ist, der mit Schaufeln (12) ausgestattet ist, zum Injizieren eines Fluids unter Druck zum Lockern der Materialien einerseits und zum Zusetzen eines Bindemittels zu den gelockerten Materialien mit einem niedrigeren Druck im Gegenstrom andererseits.
15. Vorrichtung nach Anspruch 14, **dadurch gekennzeichnet, dass** Schaufeln (12) eine Gesamtlänge zwischen etwa 0,3 und etwa 5 m aufweisen.
16. Vorrichtung nach Anspruch 14 oder 15, **dadurch gekennzeichnet, dass** Schaufeln (12) eine rohrförmige Gestalt aufweisen und Öffnungen (13) zum Injizieren eines Fluids und/oder eines Bindemittels mit hohem Druck aufweisen.
17. Vorrichtung nach Anspruch 14 oder 15, **dadurch gekennzeichnet, dass** Schaufeln (12) durch Abschnitte gebildet werden, an welchen Rohrleitungen zum Injizieren eines Fluids mit hohem und/oder niedrigem Druck und/oder eines Bindemittels befestigt sind.
18. Vorrichtung nach einem beliebigen der Ansprüche 14-16, **dadurch gekennzeichnet, dass** mit jeder der rohrförmigen Schaufeln (12) ein rohrförmiges Element (15) zum Injizieren eines Fluids mit einem Bindemittel mit niedrigerem Druck durch Öffnungen (13') und im Gegenstrom zu der Hochdruckinjektion verbunden ist.
19. Vorrichtung nach einem beliebigen der Ansprüche 14-18, **dadurch gekennzeichnet, dass** der Rotationskopf (10) mit Verstärkungsmitteln (16) versehen ist.
20. Vorrichtung nach einem beliebigen der Ansprüche 11-19, **dadurch gekennzeichnet, dass** das Rohr (5) an seinem unteren Ende mit einem Schneidemittel versehen ist.

#### Revendications

1. Procédé pour réaliser un pieu de fondation mixte dans des couches souterraines en stabilisant la terre, consistant à forer un trou dans les couches souterraines, à ameubler la terre et à mélanger les couches souterraines à l'intérieur du trou de forage avec un agent liant pour stabiliser la terre et à former le pieu de fondation mixte, le trou étant formé en introduisant un ensemble de forage composé d'un organe mélangeur entraîné en rotation (4) et d'un tube (5) dans les couches souterraines, ledit organe mélangeur (4) s'étendant sensiblement à l'intérieur dudit tube (5) et coaxialement à celui-ci et étant pourvu d'une pluralité d'aubes mélangeuses (8), à injecter l'agent liant dans la terre et à mélanger la terre avec l'agent liant au moyen de l'action mécanique des aubes (8) formant ainsi un pieu mixte souterrain, après quoi l'ensemble de forage est extrait des couches souterraines en le tirant vers le haut, **caractérisé en ce qu'un** fluide est injecté dans la terre à stabiliser par des jets à haute pression en vue d'ameubler et de découper les couches souterraines tout en ajoutant l'agent liant aux matériaux ameublés des couches souterraines, **en ce que** le tout est mélangé au moyen de l'action mécanique des aubes (8) et par la turbulence créée par les jets à haute pression et **en ce que** le tube (5) et l'organe mélangeur (4) sont mis en rotation dans des sens opposés pendant que l'ensemble de forage est inséré dans les couches souterraines.

2. Procédé tel que revendiqué dans la revendication 1, **caractérisé en ce que** l'agent liant est ajouté à une pression de préférence plus basse à la terre ameublée par lesdits jets à haute pression, et à contre courant desdits jets à haute pression. 5
3. Procédé tel que revendiqué dans la revendication 1 ou 2, **caractérisé en ce que** ledit agent liant est injecté dans la terre à ameublir en employant lesdits jets à haute pression. 10
4. Procédé tel que revendiqué dans la revendication 2 ou 3, **caractérisé en ce que** ledit agent liant est simultanément injecté à une haute pression au moyen desdits jets à haute pression et ajouté, à contre-courant de ceux-ci, à une pression plus basse aux matériaux ameublis. 15
5. Procédé tel que revendiqué dans l'une quelconque des revendications 1 - 3, **caractérisé en ce que** les propriétés du fluide utilisé dans les jets à haute pression sont de nature à permettre facilement de découper lesdits matériaux terreux, disloquant ainsi la structure de la terre, à permettre de déloger au moins en partie les particules disloquées, et enfin à permettre de lier de nouveau les particules de terre en une nouvelle structure de terre solide, et **en ce que** le fluide est injecté selon un schéma rotatif par lequel des turbulences sont créées afin de mieux homogénéiser les matériaux terreux et fluides. 20 25
6. Procédé tel que revendiqué dans l'une quelconque des revendications 1 - 5, **caractérisé en ce que** lesdits matériaux terreux sont ameublis en utilisant des jets à haute pression à une pression entre 5 et 1000 bar. 30
7. Procédé tel que revendiqué dans la revendication 2 ou 4, **caractérisé en ce que** ladite pression plus basse est choisie entre 1 bar et 50 bar. 35
8. Procédé tel que revendiqué dans l'une quelconque des revendications 1 - 7, **caractérisé en ce que** le fluide utilisé dans les jets à haute pression comprend de l'eau et / ou de l'air. 40
9. Procédé tel que revendiqué dans la revendication 8, **caractérisé en ce que** ledit agent liant est injecté conjointement avec ledit fluide. 45
10. Procédé tel que revendiqué dans l'une quelconque des revendications 1 - 9, **caractérisé en ce que** l'agent liant comprend au moins un du ciment, de la bentonite, des cendres volantes, de la chaux, des polymères, du mortier, des types de ciment dérivés, des gels ou une combinaison de ceux-ci. 50
11. Dispositif pour réaliser un pieu de fondation mixte dans des couches souterraines comprenant un ensemble de forage composé d'un tube (5) et d'un organe mélangeur (4), lequel ensemble de forage peut être manipulé par l'action d'un dispositif manipulateur (1) et enfoncé dans les couches souterraines par l'action d'une tête de forage (3), la tête de forage (3) comprenant deux moteurs d'entraînement rotatifs (3a, 3b), notamment un moteur rotatif (3b) apte à entraîner le tube (5) en rotation et un moteur rotatif (3a) apte à d'entraîner l'organe mélangeur (4) en rotation, lequel organe mélangeur (4) s'étend sensiblement à l'intérieur dudit tube (5) et coaxialement à celui-ci et est pourvu d'une pluralité d'aubes mélangeuses (8), le dispositif comprenant des moyens permettant d'injecter un agent liant dans les couches souterraines, le dispositif manipulateur comprenant des moyens pour tirer l'ensemble de forage (4, 5) vers le haut et l'enlever des couches souterraines après la formation du pieu de fondation mixte dans les couches souterraines, **caractérisé en ce que** l'organe mélangeur (4) contient au moins sur une partie de sa surface une pluralité d'ouvertures (13) par lesquelles un fluide peut être injecté sous haute pression dans la terre et **en ce que** le tube (5) et l'organe mélangeur (4) sont adaptés pour être mis en rotation dans des sens opposés pendant que l'ensemble de forage est inséré dans les couches souterraines. 55
12. Dispositif selon la revendication 11, **caractérisé en ce que** les ouvertures (13) sont situées sur les aubes mélangeuses (8).
13. Dispositif selon la revendication 11 ou 12, **caractérisé en ce que** les ouvertures (13) sont situées principalement à l'extrémité inférieure de l'organe mélangeur (4).
14. Dispositif selon la revendication 13, **caractérisé en ce que** l'organe mélangeur (4) est pourvu au moins à son extrémité inférieure d'une tête rotative (10) équipée de lames (12) pour, d'une part, injecter sous pression un fluide pour ameublir les matériaux et, d'autre part, ajouter à une pression plus basse, à contre-courant, un agent liant aux matériaux ameublis.
15. Dispositif selon la revendication 14, **caractérisé en ce que** les lames (12) ont une longueur hors tout comprise entre approximativement 0,3 et approximativement 5m.
16. Dispositif selon la revendication 14 ou 15, **caractérisé en ce que** les lames (12) sont de forme tubulaire et ont des ouvertures (13) permettant d'injecter à une haute pression un fluide et / ou un agent liant.
17. Dispositif selon la revendication 14 ou 15, **caracté-**

**risé en ce que** les lames (12) sont constituées par des sections auxquelles sont attachés des tuyaux permettant d'injecter un fluide à une haute et / ou à une basse pression, et / ou un agent liant.

5

- 18.** Dispositif selon l'une quelconque des revendications 13 - 16, **caractérisé en ce qu'**à chacune des lames tubulaires (12) est relié un élément tubulaire (15) permettant d'injecter par des ouvertures (13') un fluide avec un agent liant à une pression plus basse et à contre-courant de l'injection à haute pression.

10

- 19.** Dispositif selon l'une quelconque des revendications 13 -18, **caractérisé en ce que** ladite tête rotative (10) est pourvue de moyens de renforcement (16).

15

- 20.** Dispositif selon l'une quelconque des revendications 11 -19, **caractérisé en ce que** le tube (5) est pourvu à son extrémité inférieure d'un moyen de coupe.

20

25

30

35

40

45

50

55

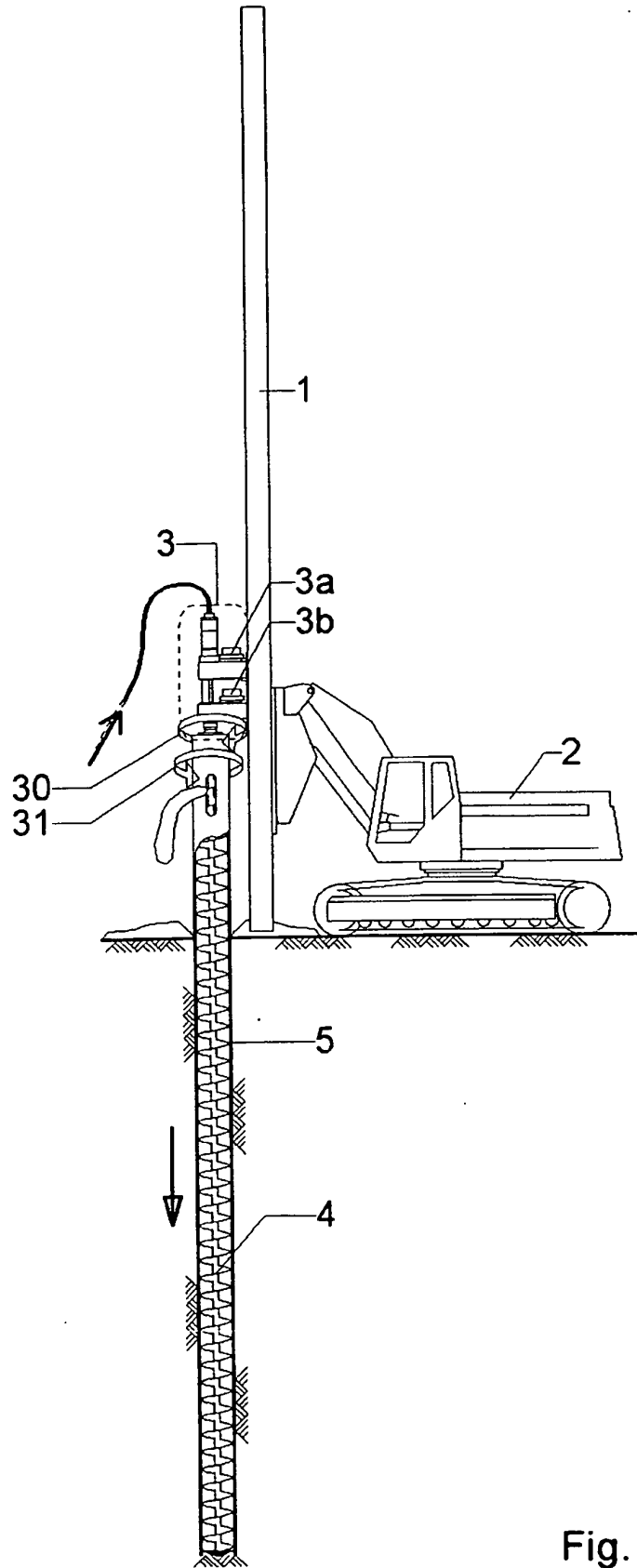

Fig. 1a

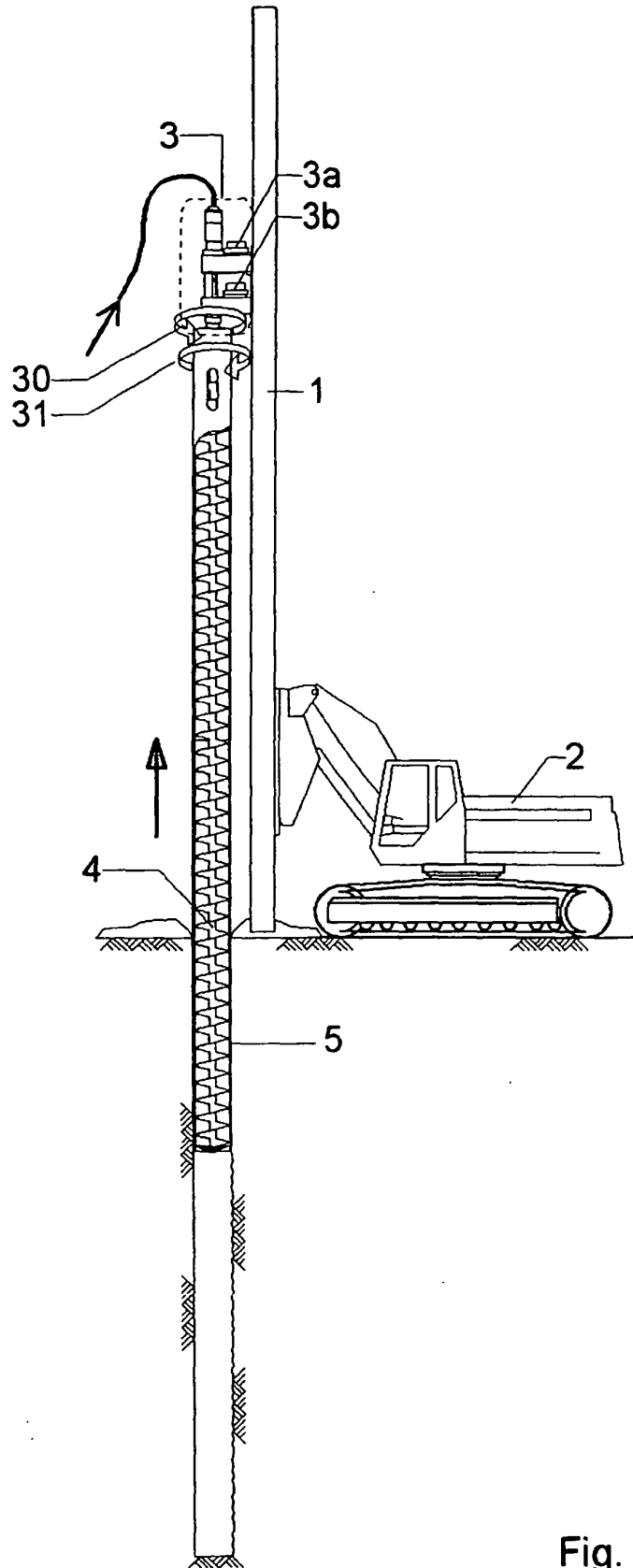

Fig. 1b

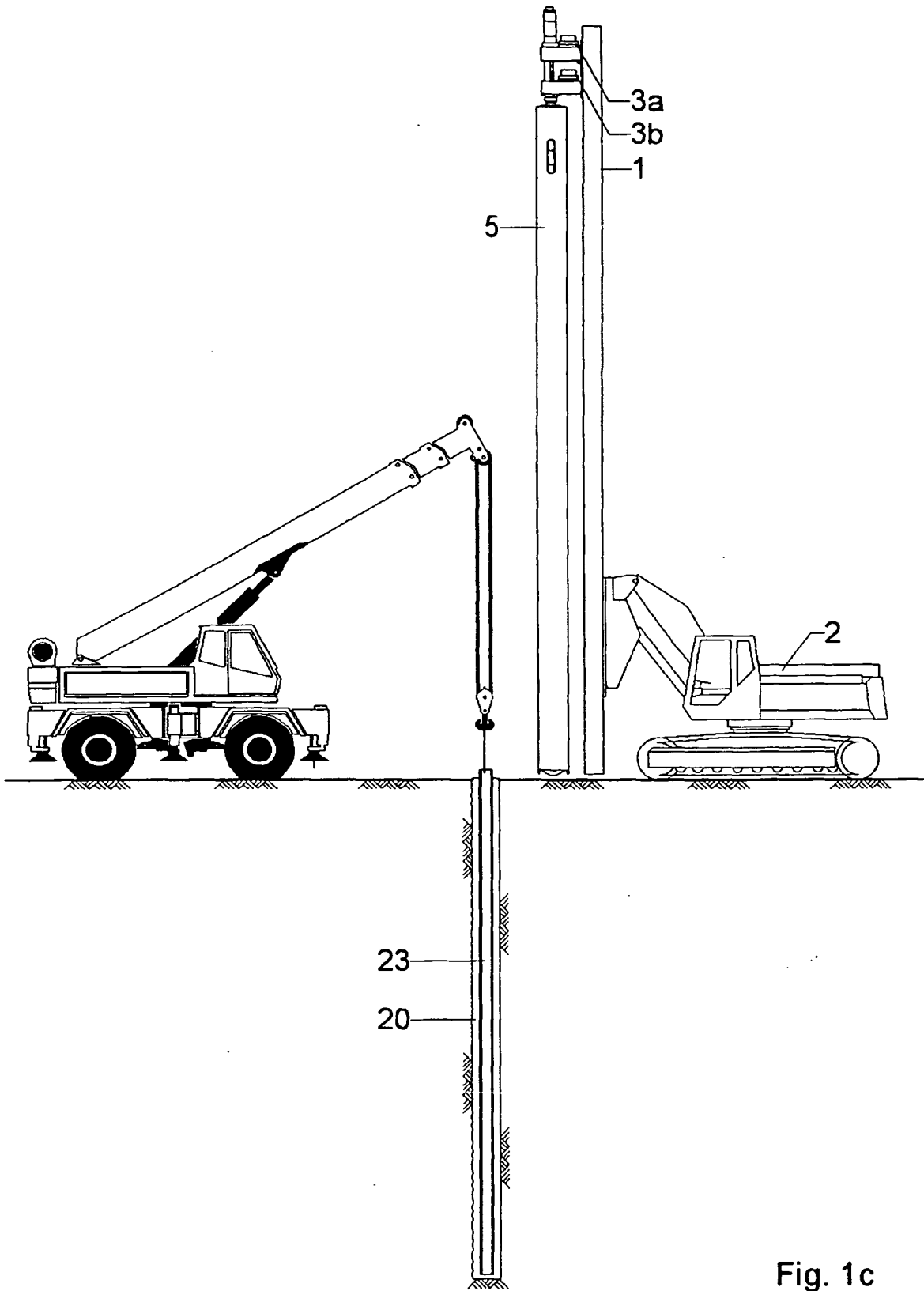
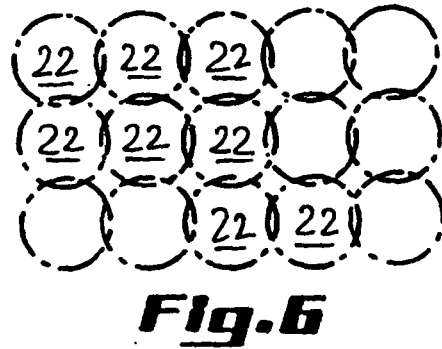
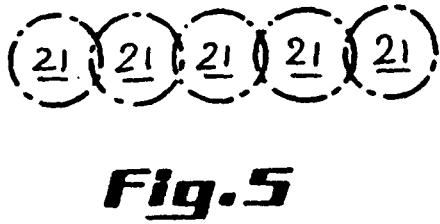
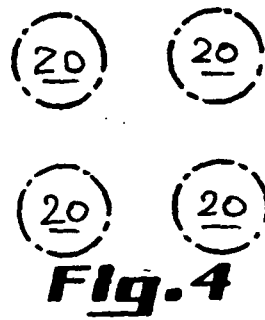
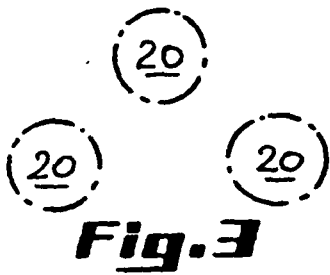

Fig. 1c





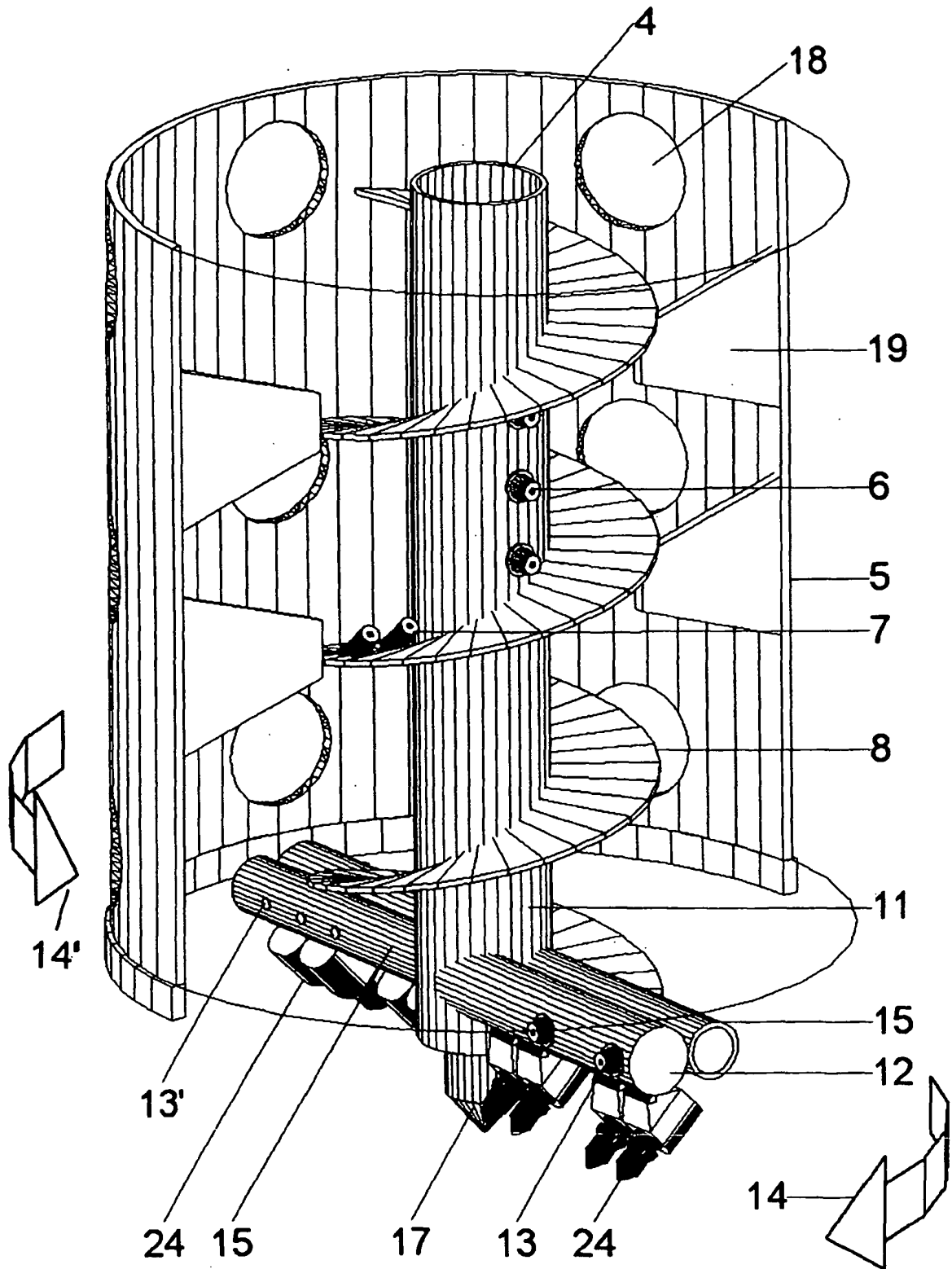

Fig. 7

**REFERENCES CITED IN THE DESCRIPTION**

*This list of references cited by the applicant is for the reader's convenience only. It does not form part of the European patent document. Even though great care has been taken in compiling the references, errors or omissions cannot be excluded and the EPO disclaims all liability in this regard.*

**Patent documents cited in the description**

- DE 10216952 A [0002]
- JP 2000273864 A [0004]
- JP 2004137670 A [0005]
- EP 1045073 A [0006]
- JP 09060463 B [0007]
- DE 3831547 [0008]