

Sept. 16, 1930.

F. W. RUDLIN

1,775,917

DRIVING DEVICE

Filed May 11, 1928

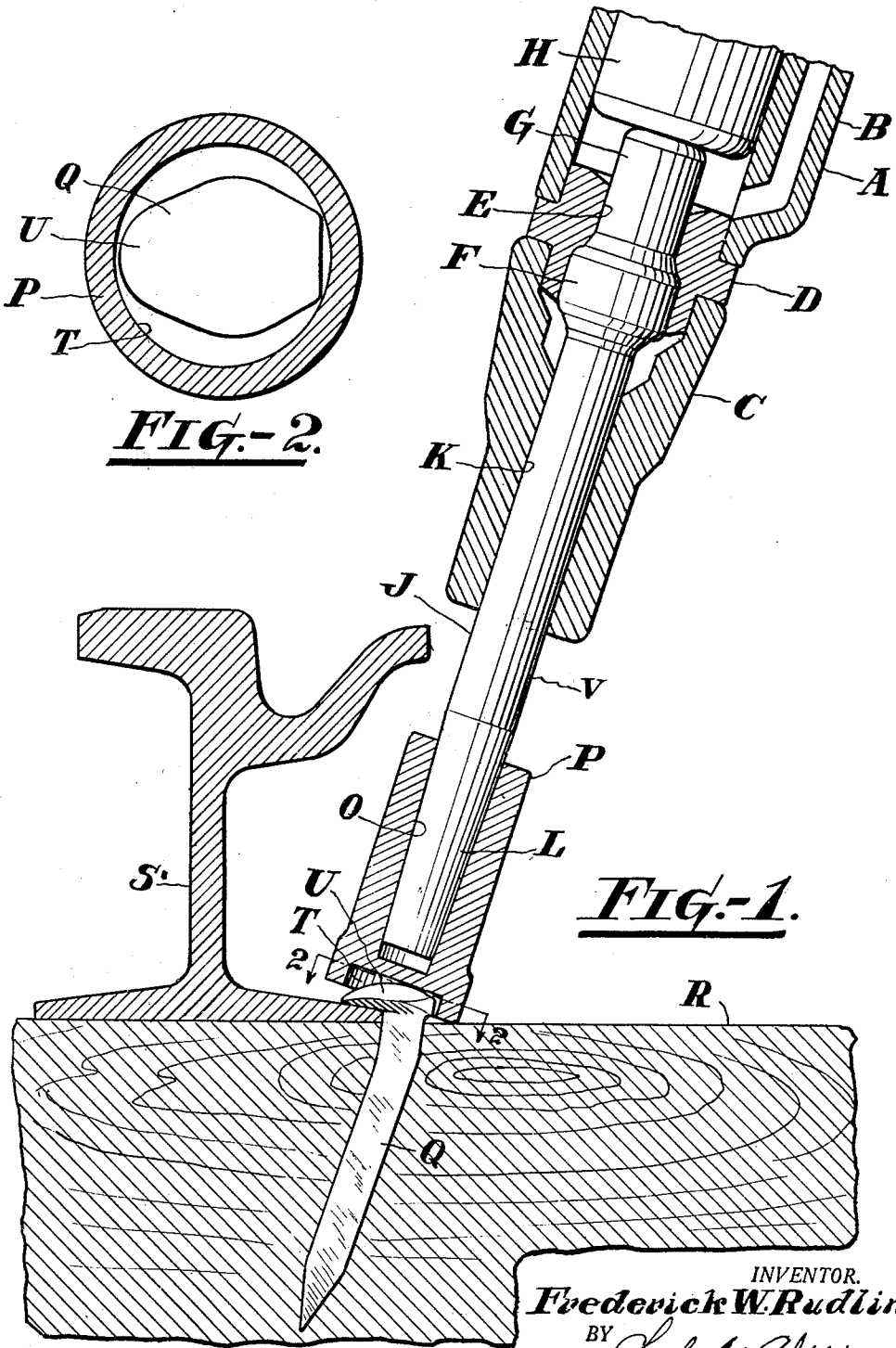

FIG.-2.

FIG.-1.

INVENTOR.
Frederick W. Rudlin
BY *Arthur A. Allen*
HIS ATTORNEY

UNITED STATES PATENT OFFICE

FREDERICK W. RUDLIN, OF PHILLIPSBURG, NEW JERSEY, ASSIGNOR TO INGERSOLL-RAND COMPANY, OF JERSEY CITY, NEW JERSEY, A CORPORATION OF NEW JERSEY

DRIVING DEVICE

Application filed May 11, 1928. Serial No. 276,911.

This invention relates to driving devices, but more particularly to a driving device adapted for attachment to a pneumatic tool of the type employed for driving spikes and similar articles.

One object of the invention is to enable the hammer tool to be retained in striking relation with the spike unaffected by the vibration set up in the tool during its operation.

Other objects will be in part obvious and in part pointed out hereinafter.

In the drawings accompanying the specification and in which similar reference characters refer to similar parts,

Figure 1 is a sectional elevation of a pneumatic tool equipped with a driver constructed in accordance with the practice of the invention, and

Figure 2 is a transverse view taken on the line 2—2 of Figure 1 looking in the direction indicated by the arrows.

Referring to the drawings, the invention is shown applied to a pneumatic tool A, only the forward portion of which is shown. The tool A comprises a cylinder B, a front head C, and a front cylinder washer D adapted to centralize the front head with respect to the cylinder. A bore E in the front cylinder washer D forms a seat for an anvil block F having a stem G which extends into the front end of the cylinder to receive the blows of the hammer piston H.

In accordance with the practice of the invention, the anvil block F is provided with an integral shank J which extends slidably through a bore K in the front head C and projects forwardly of said front head. At the front end of the shank J is a tapered portion L which frictionally engages a tapered bore O of a driving head P for maintaining said driving head on the shank.

In driving spikes and similar articles with pneumatic tools of the type illustrated a difficulty frequently encountered is that of maintaining the tool in striking relation with the article intended to be driven. This is due partly to the small area of contact between the striking end of the piston or its equivalent, such as the anvil block F and the article intended to be driven, as for instance,

a spike Q driven into a tie R for securing a rail S thereto. In order that the tool may be readily maintained in the correct position relatively to the spike Q, the head P is provided with a recess T in its forward end to engage loosely the head U of the spike Q. The recess T is preferably of less depth than the thickness of the head U and of somewhat larger diameter than the maximum width of the head U so that the head U may readily enter the recess T.

The head P is preferably of such length that a portion V of the shank may be exposed in all positions of the anvil block F to permit the tool being shifted toward the rail S for correcting deflections of the spike in such direction.

In practice whenever it is desired to drive a spike Q, the said spike may be placed in substantially the correct position relatively to the rail S. The tool may then be seated on the spike and the piston H set in operation. After the spike has been properly started in the tie R, the operator may apply pressure to the tool A and the spike will then be rapidly driven into the tie R to secure the rail S thereto. After a spike has been driven, the tool and the head P may be removed from the spike as a unit.

The present invention is particularly adapted for use in connection with rails having side projections, as for instance, a guard flange at the head of the rail, since it enables the tool to assume the correct driving position for driving spikes on the side of the rail at which the projection overhangs the bottom flange.

I claim:

In a driving device, the combination of a hammer tool having a cylinder and a front head, a front cylinder washer for centralizing the front head relatively to the cylinder, a hammer piston in the cylinder, an anvil block in the front head and the front cylinder washer and adapted to extend with its rear end into the cylinder to receive the blows of the hammer piston and extending with its forward end in advance of the front head, a collar on the anvil block cooperating with the front cylinder washer to limit rearward

movement of the anvil block, a head on the forward end of the anvil block spaced from the front end of the front head when said anvil block is in the rearmost limiting position, and a recess in the forward end of the head to loosely engage the head of a spike for maintaining the tool in driving relation with a spike during the driving thereof.

6 In testimony whereof I have signed this specification.

10 FREDERICK W. RUDLIN.

15

20

25

30

35

40

45

50

55

60

65