



(11) **EP 1 958 558 A8**

(12) **CORRECTED EUROPEAN PATENT APPLICATION**

(15) Correction information:
Corrected version no 1 (W1 A2)
Bibliography INID code(s) 71

(51) Int Cl.:
A47K 3/28 (2006.01)

(48) Corrigendum issued on:
12.11.2008 Bulletin 2008/46

(43) Date of publication:
20.08.2008 Bulletin 2008/34

(21) Application number: **08002363.3**

(22) Date of filing: **08.02.2008**

(84) Designated Contracting States:
AT BE BG CH CY CZ DE DK EE ES FI FR GB GR HR HU IE IS IT LI LT LU LV MC MT NL NO PL PT RO SE SI SK TR
Designated Extension States:
AL BA MK RS

- **Taylor, Frederick James**
East Sussex BN20 9JA (GB)
- **Taylor, Jonathan Robert**
East Sussex BN20 9JA (GB)

(30) Priority: **13.02.2007 GB 0702764**

(72) Inventor: **Gontar, Antoni Harold Nikolas**
Pevensey, East Sussex BN24 6JH (GB)

(71) Applicants:

- **Gontar, Antoni Harold Nikolas**
14 Val Princes Road
Pevensey Bay
Pevensey
East Sussex BN24 6JH (GB)

(74) Representative: **HOFFMANN EITL**
Patent- und Rechtsanwälte
Arabellastrasse 4
81925 München (DE)

(54) **Shower seat**

(57) A shower seat (2) has a seat (8) and a back rest (10) both pivotably connected to side supports (4,6). The back rest (10) pivots between a lowered position and a raised position to permit movement of the seat (8) between a lowered, seating position and a raised, storage position between the side supports (4,6). In the storage position, the back rest (10) is lowered to substantially cover the seat (8). The back rest (10) therefore functions as a back rest in the seating position and also a rest in the storage position against which a person may lean when standing to shower.

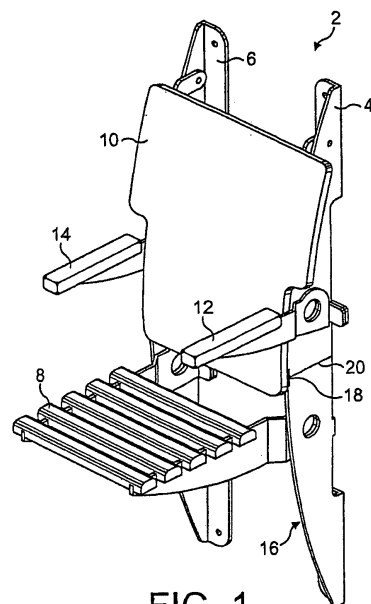

FIG. 1