

H. A. HOAGLAND.
FIXTURE FOR TERMINAL BOXES.
APPLICATION FILED JUNE 29, 1903.

NO MODEL.

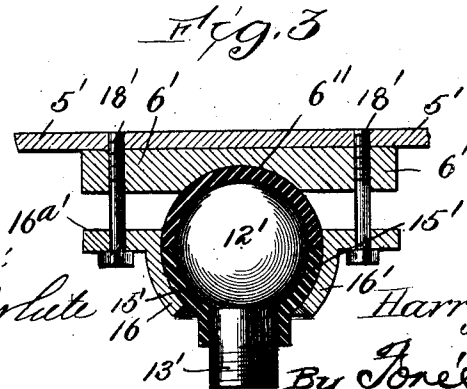
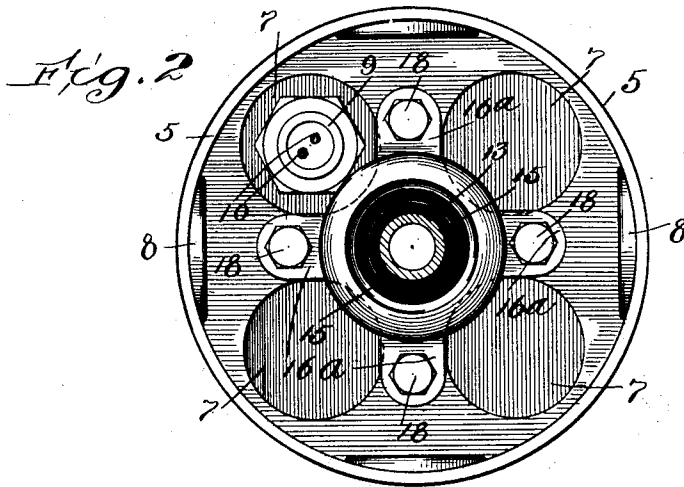
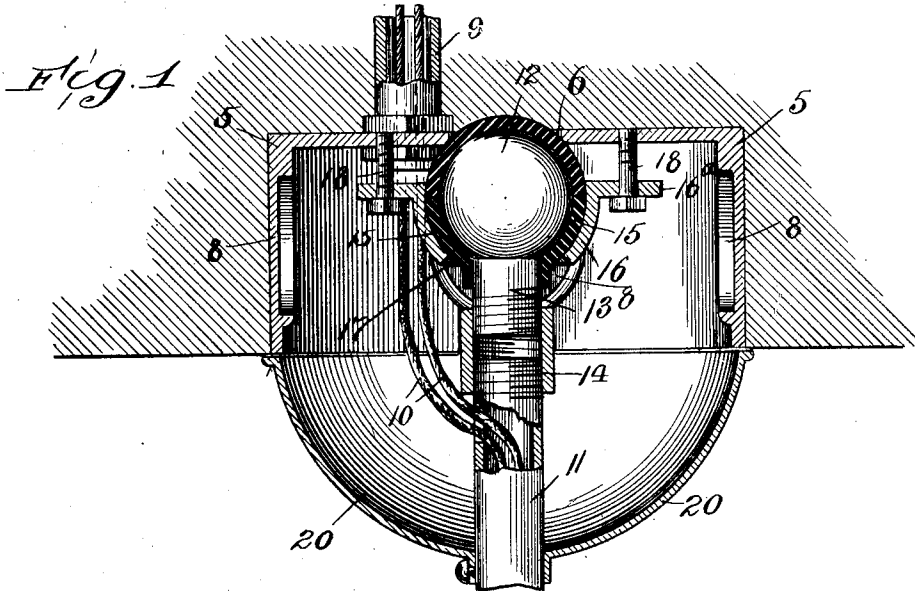

Witnesses:
Samuel R. White
Ray White

Inventor:
Harry A. Hoagland
By J. J. Rain
Atty.

UNITED STATES PATENT OFFICE.

HARRY A. HOAGLAND, OF CHICAGO, ILLINOIS.

FIXTURE FOR TERMINAL-BOXES.

SPECIFICATION forming part of Letters Patent No. 745,494, dated December 1, 1903.

Application filed June 29, 1903. Serial No. 163,518. (No model)

To all whom it may concern:

Be it known that I, HARRY A. HOAGLAND, of Chicago, in the county of Cook and State of Illinois, have invented certain new and useful Improvements in Fixtures for Terminal-Boxes; and I hereby declare that the following is a full, clear, and exact description thereof, reference being had to the accompanying drawings, which form part of this specification.

My invention relates to fixtures for terminal-boxes, especially adapted for interior electric wiring.

The primary object of my invention is to provide a fixture adapted for use in conjunction with the ordinary terminal-box of the "knock-out" type commonly in use which will overcome various objections now incident to the use of such boxes.

In the present practice of interior wiring the terminal-boxes are placed in position before the plastering or tiling is applied to the walls or ceilings, and it sometimes happens that the open face of the box and the plaster do not aline, the box being tilted in one direction or another with reference to the wall-surface. Consequently light brackets or chandeliers attached to said outlet-box in the ordinary manner are not "plumb" or at right angles to the wall-surface. This difficulty I propose to overcome in my present invention by providing a fixture adapted for connection to the ordinary outlet or terminal box, one member whereof is universally movable relative to the box, said movable member being arranged to receive and support the bracket or chandelier to be connected through the terminal-box.

Another objectionable feature incident to the use of the ordinary terminal or outlet box is that in the use of ordinary fixtures in conjunction therewith it is necessary to use an insulating-joint between the bracket or chandelier and the supporting fixture part secured to the terminal-box. This difficulty I also overcome in the use of my invention by insulating the movable member of my improved fixture from its surrounding supports, thereby making unnecessary the usual insulating joint.

Other and further objects of my present invention will become apparent to those skilled

in the art from the following description and the appended claims.

In the drawings, Figure 1 is a central vertical section with parts in elevation of a terminal-box and its attachments embodying my invention. Fig. 2 is a horizontal section taken on line 2 2 of Fig. 1. Fig. 3 is a detail illustrating a modified form of attachment of my improved fixture to the terminal-box.

Throughout the drawings like numerals of reference refer to like parts.

In the drawings, 5 indicates generally a terminal-box of usual construction, having at its top a central perforation 6 and a suitable number of thin portions or knock-outs 7, adapted to be broken out to afford ingress to the electric-circuit wires. Suitable similarly-weakened portions are provided in the sides of the box at 8 8 for a like purpose.

9 indicates a wire-conduit in open communication with the interior of the box, and 10 10 indicate insulated electric wires entering the box through the conduit 9 and passing therefrom into the interior of the hollow bracket or chandelier 11, supported from the box in the manner to be described.

The movable member of my improved fixture comprises a ball 12, having projecting therefrom a threaded stud or neck 13, arranged to receive a coupling 14, which engages the screw-threaded upper extremity of the bracket or chandelier 11 and carries the bracket or chandelier.

15 indicates a covering of insulation applied to the ball 12 and a portion of its neck 13 and suitably fixed thereto. The insulating-coating may, if desired, be of molded fiber formed into semispherical portions and suitably cemented or otherwise intimately attached to the ball and its neck 13, or the insulation may be of hard rubber intimately applied by vulcanizing, or it may be of any other suitable hard insulating material cured to the ball in any desired manner.

In the construction illustrated in Fig. 1 the ball, with its insulation, is arranged to fit into the aperture 6, formed in the top of the box, and is supported therein by means of a socket-plate 16. The cup-shaped portion of the socket-plate 16 is open at its top, as indicated at 17, said opening being of greater diameter than the width of the insulated por-

tion of the neck 13 of the movable fixture member, so as to permit the latter to pass therethrough and have room for play in any direction. It will be noted that the insulation extends sufficiently far down the neck 13 to prevent contact between said neck and the socket when the neck is moved to its limit of movement within the aperture 17. Bolts 18, passing through ears 16^a, projecting from the socket-plate, are threaded into the top of the box to afford means for clamping the socket-plate tightly upon the ball and pressing the latter into its aperture 6.

20 indicates a canopy secured to the bracket or chandelier 11 and covering the box 8 and the fixtures inclosed therein. It will be understood that the canopy 20 is arranged out of electrical contact with the box 8 in any convenient manner.

In Fig. 3 is illustrated a modification of my invention whereby it is adapted for use in conjunction with boxes having no central aperture corresponding with the aperture 6 in Fig. 1. In said Fig. 3, 5' indicates the top of a knock-out box, and 6' a plate bearing thereon and provided with a central depression 6''. 12' indicates the small portion of the movable fixture, and 15' its insulation, arranged in a manner similar to that illustrated in Fig. 1. 16' indicates a cup-shaped socket-plate identical with that illustrated in Fig. 1, and 18' indicates bolts passing through the socket-plate 16', bearing-plate 6', and into the top 5' of the box, so as to secure all of said parts together.

The utility of my invention is primarily as follows: It is apparent that in assembling the device before the screws 18 are tightened to firmly fix the ball in position in its socket said ball may be adjusted to move its stem or neck 13 in any direction, so that the bracket or chandelier 11, secured to said stem, may be adjusted to any angle with reference to the plane of the mouth of the box. Consequently should a box be set at any angle to the plane of the plastering the bracket may be applied to the ball-fixture while the latter is loosely held by reason of the looseness of the screws 18. In such instance the weight of the bracket or chandelier 11 serves to bring the fixture to plumb or vertical position irrespective of the distorted angular arrangement of the box. The screws 18 being thereupon tightened, the ball is tightly clamped between the plate 16 and the edges of the aperture 6, so that it is fixedly retained against movement from its proper position. Again, it will be apparent that the canopy 20 being disposed out of electrical contact with the box 8 and the movable member of the fixture being completely insulated from its surrounding supports by the coating 15 perfect insu-

lation of the bracket or chandelier 11 from any of the supporting-fixtures, irrespective of the position of the bracket or chandelier, is secured. Thus in case the insulation of one of the wires 10 should become broken within or close to the bracket 11 the circuit including the wire is prevented from being grounded through the bracket or chandelier 11 and the associated fixtures.

Having thus described my invention, what I claim as new, and desire to secure by Letters Patent of the United States, is—

1. In combination, a terminal-box for interior electrical wiring, a socket member carried by the box, and provided with an aperture, a ball member, interfitting with said socket member, a bracket or chandelier connected with the ball member, said connection being made through the aperture to the socket member, and insulation completely surrounding the ball member and extending through the aperture in the socket member.

2. The combination with a terminal-box for interior electric wiring, and a bracket or chandelier to be connected to said box, of a ball member, bearing on one side against said box and at its other side connected with the bracket or chandelier, a socket member, embracing said ball member, provided with an aperture through which the connection of the ball member and the bracket or chandelier member passes, insulation completely surrounding the ball member and extending through the opening in the socket member, and bolts passing through said socket member into the box for clamping the socket member and the insulated ball member in fixed relation to the box.

3. In combination with a conduit terminal-box 5, and a bracket or chandelier 11, screw-threaded at its upper end, a fixture for securing the bracket to the box comprising a movable member having a ball 12 and a screw-threaded neck 13, a coupling 14 connecting the neck 13 and the threaded end of the bracket or chandelier 11, an insulating-coating 15 covering the ball, and insulating the same from its support, a socket member 16 partially encompassing the ball, and provided with an aperture 17 through which the insulated stem or neck of said ball projects, and bolts 18, arranged to secure said socket member to the box 5, to securely clamp the ball between the socket member and the box 5.

In testimony that I claim the foregoing as my own I affix my signature in presence of two witnesses.

HARRY A. HOAGLAND.

Witnesses:
 FORÉE BAIN,
 MARY F. ALLEN.