

No. 840,902.

PATENTED JAN. 8, 1907.

J. J. BROWN,  
SECURING MEANS FOR RAIL JOINTS.  
APPLICATION FILED MAY 9, 1906.

Fig. 1.

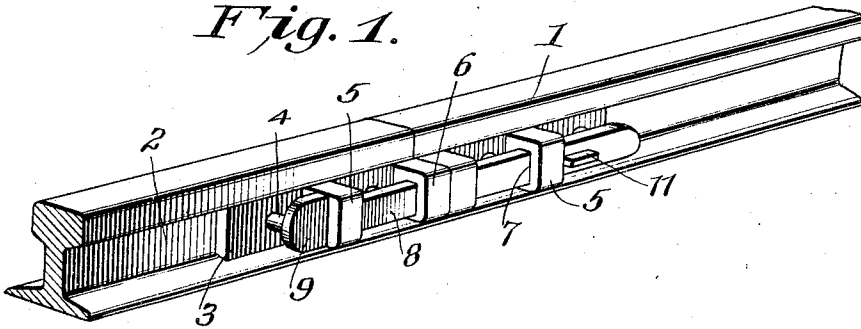

Fig. 2.

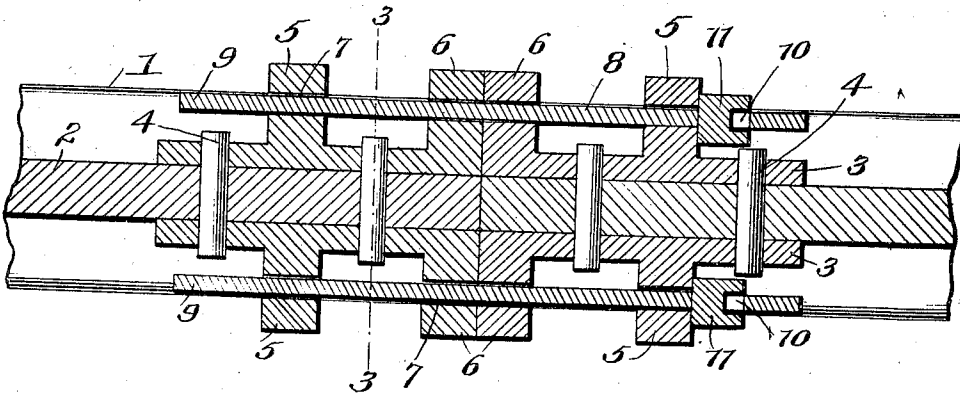

Fig. 3.

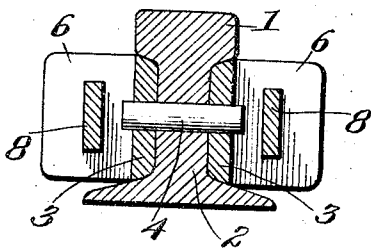
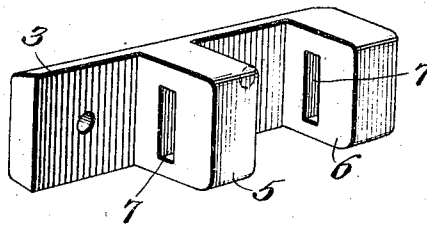

Fig. 4.



Inventor

John J. Brown

Witnesses

*M. C. Lyddane*  
*A. W. Fitzgerald*

By

*W. J. Fitzgerald*  
Attorneys

# UNITED STATES PATENT OFFICE.

JOHN J. BROWN, OF PHOENIX, MISSISSIPPI.

## SECURING MEANS FOR RAIL-JOINTS.

No. 840,802.

Specification of Letters Patent.

Patented Jan. 8, 1907.

Application filed May 9, 1906. Serial No. 316,009.

*To all whom it may concern:*

Be it known that I, JOHN J. BROWN, a citizen of the United States, residing at Phoenix, in the county of Yazoo and State of Mississippi, have invented certain new and useful Improvements in Securing Means for Rail-Joints; and I do hereby declare the following to be a full, clear, and exact description of the invention, such as will enable others skilled in the art to which it appertains to make and use the same.

My invention relates to new and useful improvements in securing means for rail-joints; and my object is to provide a device of this class whereby contraction and expansion of the rails will be compensated for.

A further object is to so construct the device that the ends of the rails will be securely held together.

Other objects and advantages will be hereinafter made clearly apparent in the specification and pointed out in the claims.

In the accompanying drawings, which are made a part of this application, I have shown the preferred form of my invention.

In said drawings, Figure 1 is a perspective view of the meeting ends of a pair of railroad-bars, showing my improved device secured thereto. Fig. 2 is a horizontal central sectional view thereof. Fig. 3 is a transverse vertical sectional view as seen from line 3 3, Fig. 2; and Fig. 4 is a perspective view of a portion of my improved device.

Referring to the figures by numerals of reference, 1 and 2 indicate the usual form of railroad-rails, to the ends of which are secured plates 3, a pair of said plates being secured on each side of the meeting ends of said rails by means of pins or bolts 4 passing through said plates and the rails. The plates 3 are provided with projections or ears 5 and 6, said ears having registering ways 7 therein, which are adapted to take locking-bars 8, said locking-bars being provided with heads 9 at one end and with slots 10 at the opposite end thereof. The ears 6 are disposed at one end of the plates 3, and said plates are so placed upon the rails that the outer faces of the ears 6 will be flush with the ends of the rails, so that when said rails are joined together end to end the ears 6 of the plates 3, secured to the ends of the respective rails,

will abut against each other, and the ways 7 therein will aline with each other. After the rails are placed in position and the ways in the respective ears are brought into alignment with each other the bars 8 are inserted through said ways and keys 11 secured in the slots 10 in the ends of said bars to prevent the casual removal of said bars. The distance between the heads upon the locking-bars 8 and the keys 11 in the slots 10 is greater than the distance between the ears 5 upon the respective registering plates 3, thereby permitting the ends of the rails to move slightly apart to compensate for any contraction which may take place.

While I have shown pins as securing the plates 3 to the rails, it will be understood that bolts having the usual retaining-nuts thereon may be substituted for said pins, and it will be further seen that my improved lock may be quickly and readily secured to the rails and the locking-bars passed there-through, enabling the rails to be quickly connected together or separated.

What I claim is—

1. The combination with rails of the class described; of plates, means to secure said plates to the rails, ears on said plates having registering ways therein, a locking-bar adapted to be disposed in said ways to secure the rails together, a head at one end of said locking-bar, and a key adapted to be seated in a slot in the opposite end of said bar, the distance between said head and key being greater than the distance between the opposing ears.

2. The combination with track-rails; of plates secured to each side of said rails, one end of each of said plates being flush with the end of the rail, means to secure said plates to the rails, ears on said plates having registering ways therein, a bar extending through the ways in said ears, and means to loosely secure said bar in said ways.

In testimony whereof I have signed my name to this specification in the presence of two subscribing witnesses.

JOHN J. BROWN.

Witnesses:

R. M. ALANHULIN,  
D. F. ROBERTS.