

E. R. & T. W. SHERIDAN.  
Paper-Cutting Machines.

No. 132,327.

Patented Oct. 15, 1872.

Fig. 2

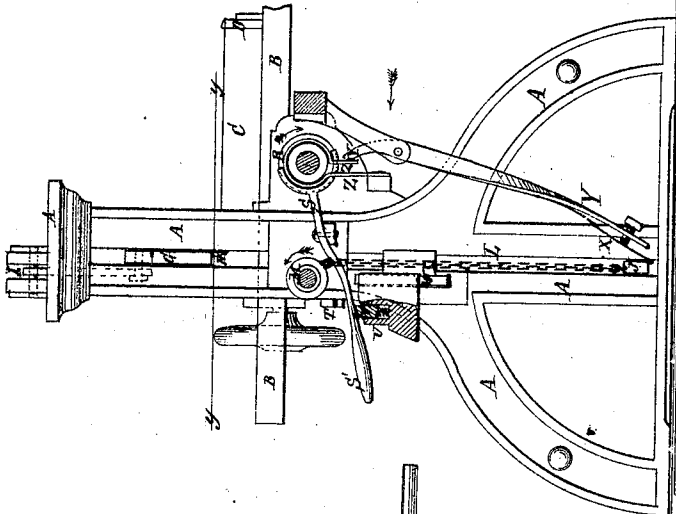
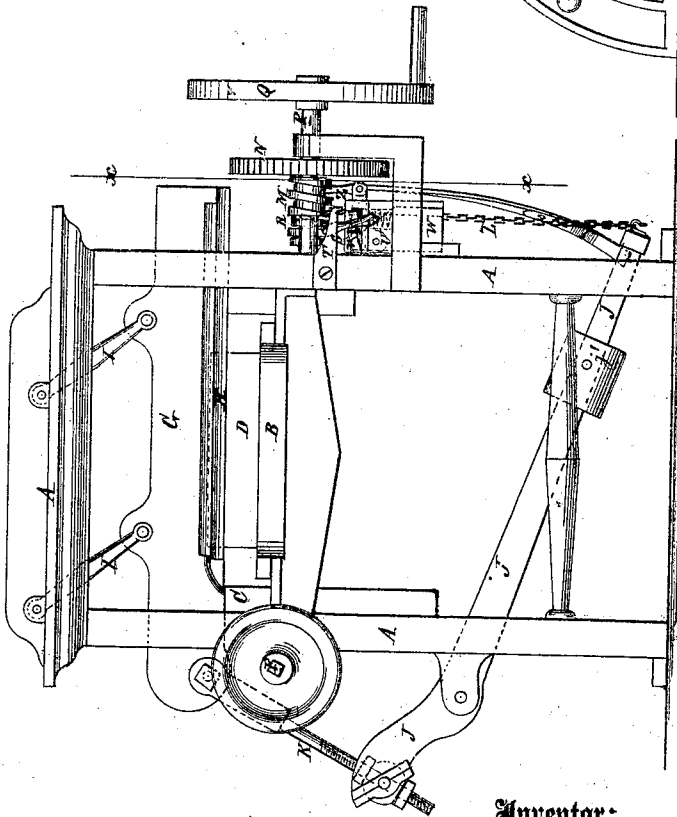

Fig. 1



Witnesses:

*A. M. Amqvist*  
*Alex. F. Roberts*

Inventor:

*E. R. Sheridan*  
*T. W. Sheridan*

PER

*Munnell*  
Attorneys.

E. R. & T. W. SHERIDAN.  
Paper-Cutting Machines.

No. 132,327.

Patented Oct. 15, 1872.

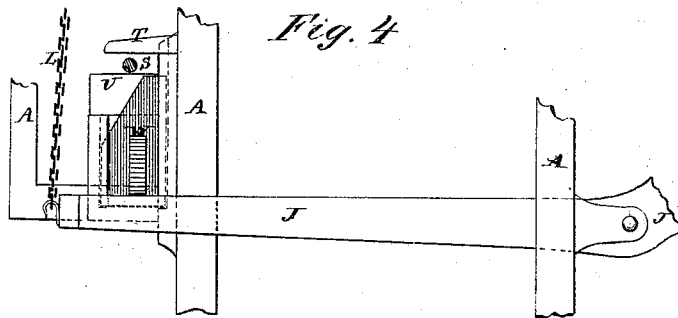
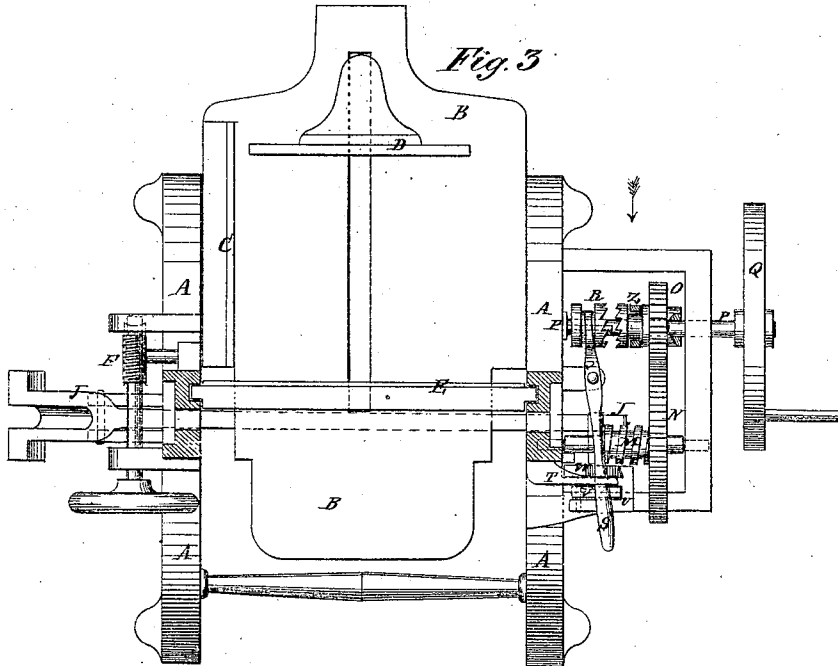

Witnesses:  
*A. W. Almqvist*  
*Alex F. Roberts*

Inventor:  
*E. R. Sheridan*  
*T. W. Sheridan*  
PER *[Signature]*  
Attorneys.

# UNITED STATES PATENT OFFICE.

EDWIN R. SHERIDAN AND THEODORE W. SHERIDAN, OF NEW YORK, N. Y.

## IMPROVEMENT IN PAPER-CUTTING MACHINES.

Specification forming part of Letters Patent No. 132,327, dated October 15, 1872.

*To all whom it may concern:*

Be it known that we, EDWIN R. SHERIDAN and THEODORE W. SHERIDAN, of New York city, in the county and State of New York, have invented a new and useful Improvement in Paper-Cutting Machine, of which the following is a specification:

Figure 1, Sheet 1, is a front view of our improved machine; Fig. 2, Sheet 1, is an end view of the same, partly in section, through the line *xx*, Fig. 1; Fig. 3, Sheet 2, is a top view of the same, partly in horizontal section, through the line *yy*, Fig. 2; Fig. 4, Sheet 2, is a detail view of the shifting-block.

Similar letters of reference indicate corresponding parts.

Our invention has for its object to improve the construction of paper-cutting machines, so as to make them more convenient in use and more effective and reliable in operation; and it consists in the construction and combination of various parts of the machine, as hereinafter more fully described.

A represents the frame-work of the machine. B is the table upon which the paper is arranged to be cut. C is the guide. D is the adjustable gage. E is the compressing or clamping bar, which is raised and lowered by racks and pinions placed beneath the table B, and operated by an endless screw, F, in the ordinary manner. G is the bar to which the knife H is secured, which bar moves up and down in slots in the frame A, and is hung from the upper part of said frame by bars or links, I, so as to move up and down in a horizontal line. The knife-bar and knife G H are moved up and down by the movements of the lever J, which is connected with said knife-bar G by an adjustable connecting-rod, K. The lever J is pivoted to the frame A, and works in a guide-slot in the lower part of the said frame A. To the end of the lever J is attached the lower end of a chain L, the upper end of which is attached to the shaft M, or to a drum placed upon and secured to said shaft. In the shaft or drum M is formed a spiral groove into which the chain L is wound as the shaft or drum M is revolved in one direction, so as to raise the lever J and draw the knife-bar and knife G H down upon the paper to make a cut. The spiral groove in the shaft or drum M keeps the coils of the chain parallel with each other, and thus

prevents the coils overlapping and the chain from kinking while being wound and unwound, so that the movement of the knife may be steady and uniform. The journals of the shaft or drum M revolve in bearings attached to the frame A, and to said shaft or drum is attached a gear-wheel, N, the teeth of which mesh into the teeth of the smaller gear-wheel O, which runs loosely upon the shaft P. The shaft P revolves in bearings attached to the frame A, and to its outer end is attached a crank fly-wheel, Q, and to it may also be attached a driving-pulley when the machine is to be driven by power. Upon the inner part of the shaft P is placed a clutch, R, which is connected with the said shaft P by a tongue and groove or other convenient means, so that it may be carried around by and with the said shaft P in its revolution, while being free to slide longitudinally upon it. The clutch R is grooved to receive the forked end of the lever S, by which it is moved outward to clutch the gear-wheel O, and carry it with the shaft P in its revolution, and inward to release said gear-wheel O and allow it to run free upon the said shaft P. The lever S is pivoted to a bracket attached to the frame A, and its free end passes out beneath the guide-bar T and above the guide-block U into such a position that it may be conveniently reached and operated by the workman. The lever S is held securely in either position by a double-inclined block, V, placed in a recess in the top of the block U, and which is held up against the said lever S by a small spring placed beneath it in the said recess. W is a block moving up and down loosely in grooves or ways in the frame A and guide-block U, and which is so formed that as the lever J approaches the upper limit of its stroke it may strike against and raise the said block W. The upper end of the trip-block W is inclined so that, as it is raised by the lever J, it may move the free end of the lever S outward, and thus operate the clutch R and release the wheel O, which allows the lever J to descend by its own weight, raising the knife-bar and knife ready to make another cut. The lever J should have an adjustable weight *j'* attached to it, to enable its rapidity of descent to be regulated, as desired. As the lever J approaches the limit of its downward movement it strikes a spring, X, attached to

the lower part of the lever Y, which checks it, prevents rebound, and at the same time moves the said lever Y. The tension of the spring X is regulated by a set-screw, as shown in Fig. 2. The lever Y is pivoted to the frame A, or to a bracket attached to said frame, and its upper end is connected with one end of the brake-band or strap Z, which passes over the hub of the gear-wheel O, or a brake-wheel attached to said gear-wheel, so that the lever J, as it reaches the lowest point of its descent, may apply the brake and stop the movement of the gear-wheels, until motion is again given by throwing the clutch into gear by operating the lever S.

Having thus described our invention, we claim as new, and desire to secure by Letters Patent—

1. The inclined trip-block W, in combination with the clutch-lever S, and the lever J that operates the knife of a paper-cutting ma-

chine, substantially as herein shown and described, and for the purpose set forth.

2. The arrangement of the brake-lever Y, in connection with the lever J that operates the knife of a paper-cutting machine, in such a way that the said lever J in its descent may strike the said brake-lever Y and apply the brakes, substantially as herein shown and described, and for the purpose set forth.

3. The combination, with the ordinary knife-holder G, pendent by pivoted straps I I from frame, of a train of operative mechanism, consisting of the rod K, lever J, chain L, and spirally-grooved drum M, arranged as described.

EDWIN R. SHERIDAN.  
THEODORE W. SHERIDAN.

Witnesses:

JAMES T. GRAHAM,  
T. B. MOSHER.