

(19) World Intellectual Property Organization  
International Bureau



(43) International Publication Date  
19 June 2003 (19.06.2003)

(10) International Publication Number  
**PCT**  
**WO 03/049631 A1**

- (51) International Patent Classification<sup>7</sup>: **A61B 18/14**
  - (21) International Application Number: PCT/US02/39701
  - (22) International Filing Date:  
11 December 2002 (11.12.2002)
  - (25) Filing Language: English
  - (26) Publication Language: English
  - (30) Priority Data:  
60/340,429 12 December 2001 (12.12.2001) US
  - (71) Applicant (for all designated States except US): **TIS-SUELINK MEDICAL, INC.** [US/US]; Suite 400, One Washington Center, Dover, NH 03820 (US).
  - (72) Inventor; and
  - (75) Inventor/Applicant (for US only): **MCCLURKEN, Michael, E.** [US/US]; 26 Deer Meadow Road, Durham, NH 03824 (US).
  - (74) Agent: **BRUESS, Steven, C.**; Merchant & Gould P.C., P.O. Box 2903, Minneapolis, MN 55402-0903 (US).
  - (81) Designated States (national): AE, AG, AL, AM, AT, AU, AZ, BA, BB, BG, BR, BY, BZ, CA, CH, CN, CO, CR, CU, CZ, DE, DK, DM, DZ, EC, EE, ES, FI, GB, GD, GE, GH, GM, HR, HU, ID, IL, IN, IS, JP, KE, KG, KP, KR, KZ, LC, LK, LR, LS, LT, LU, LV, MA, MD, MG, MK, MN, MW, MX, MZ, NO, NZ, OM, PH, PL, PT, RO, RU, SC, SD, SE, SG, SK, SL, TJ, TM, TN, TR, TT, TZ, UA, UG, US, UZ, VC, VN, YU, ZA, ZM, ZW.
  - (84) Designated States (regional): ARIPO patent (GH, GM, KE, LS, MW, MZ, SD, SL, SZ, TZ, UG, ZM, ZW), Eurasian patent (AM, AZ, BY, KG, KZ, MD, RU, TJ, TM), European patent (AT, BE, BG, CH, CY, CZ, DE, DK, EE, ES, FI, FR, GB, GR, IE, IT, LU, MC, NL, PT, SE, SI, SK, TR), OAPI patent (BF, BJ, CF, CG, CI, CM, GA, GN, GQ, GW, ML, MR, NE, SN, TD, TG).
- Published:**  
— with international search report

[Continued on next page]

(54) Title: FLUID-ASSISTED MEDICAL DEVICES, SYSTEMS AND METHODS

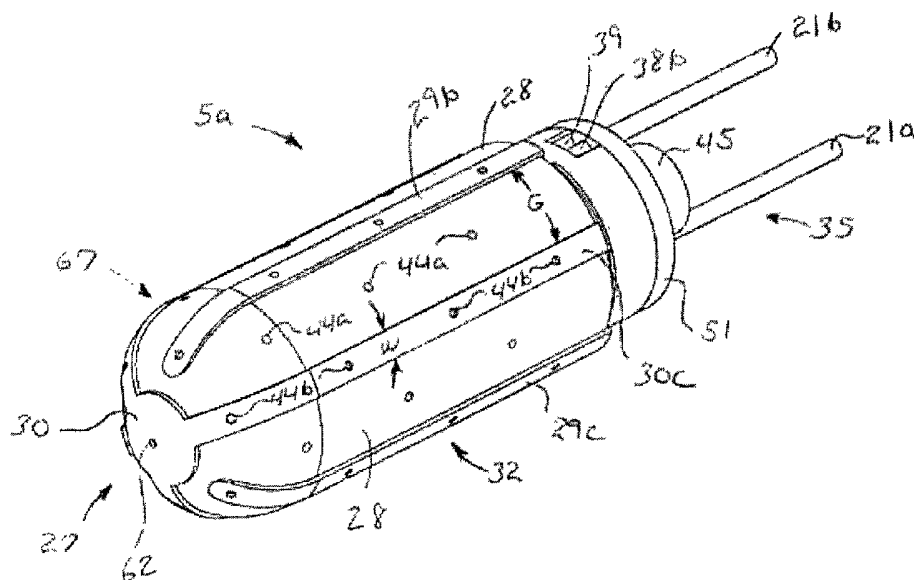

(57) Abstract: A medical device (5) is provided which comprises a catheter tube having a distal end and a lumen, and configured to assist in applying tamponage to a bleeding source in a gastrointestinal tract when flexed. A catheter tip having a catheter tip outer surface is assembled with the tube adjacent the distal end of the tube. The catheter tip comprises a probe body comprising an electrically insulative material, at least one electrode pair located on the probe body which comprises a first electrode spaced from a second electrode, and a fluid distribution manifold to direct a fluid from inside the probe body towards the tip outer surface. The manifold comprises a central passage within the probe body and a plurality of lateral passages which extend from the central passage towards the tip outer surface. An extendable injection needle is housed within the central passage to provide treatment to tissue.



WO 03/049631 A1



— before the expiration of the time limit for amending the claims and to be republished in the event of receipt of amendments

For two-letter codes and other abbreviations, refer to the "Guidance Notes on Codes and Abbreviations" appearing at the beginning of each regular issue of the PCT Gazette.

## FLUID-ASSISTED MEDICAL DEVICES, SYSTEMS AND METHODS

This application is being filed as a PCT International Patent application in the name of TissueLink Medical, Inc. (a U.S. national corporation), applicant for the designation of all countries except the US, and Michael E. McClurken (a U.S. resident and citizen), applicant for the designation of the US only, on 11 December 2002.

### Field Of The Invention

This invention relates generally to the field of medical devices, methods and systems for use upon a body during surgery. More particularly, the invention relates to electrosurgical devices, methods and systems for use upon tissues of a human body during therapeutic endoscopy.

### Background

Electrosurgical devices configured for use with a dry tip use electrical energy, most commonly radio frequency (RF) energy, to cut tissue or to cauterize blood vessels. During use, a voltage gradient is created at the tip of the device, thereby inducing current flow and related heat generation in the tissue. With sufficiently high levels of electrical energy, the heat generated is sufficient to cut the tissue and, advantageously, to stop the bleeding from severed blood vessels.

Current dry tip electrosurgical devices can cause the temperature of tissue being treated to rise significantly higher than 100 °C, resulting in tissue desiccation, tissue sticking to the electrodes, tissue perforation, char formation and smoke generation. Peak tissue temperatures as a result of RF treatment of target tissue can be as high as 320 °C, and such high temperatures can be transmitted to adjacent tissue via thermal diffusion. Undesirable results of such transmission to adjacent tissue include unintended thermal damage to the tissue.

Using saline to couple RF electrical energy to tissue inhibits such undesirable effects as sticking, desiccation, smoke production and char formation. One key factor is inhibiting tissue desiccation, which occurs if tissue temperature exceeds 100 °C and all of the intracellular water boils away, leaving the tissue extremely dry and much less electrically conductive. However, an uncontrolled or abundant flow rate of saline can provide too much cooling at the electrode/tissue interface. This cooling reduces the temperature of the target tissue being treated, and the rate at which tissue thermal coagulation occurs is determined by tissue temperature. This, in turn, can result in longer treatment time to achieve the desired tissue temperature for treatment of the tissue. Long treatment times are undesirable for surgeons since

it is in the best interest of the patient, physician and hospital to perform surgical procedures as quickly as possible.

RF energy delivered to tissue can be unpredictable and often not optimal when using general-purpose generators. Most general-purpose RF generators have modes for different waveforms (e.g. cut, coagulation, or a blend of these two) and device types (e.g. monopolar, bipolar), as well as power levels that can be set in watts. However, once these settings are chosen, the actual power delivered to tissue and associated heat generated can vary dramatically over time as tissue impedance changes over the course of RF treatment. This is because the power delivered by most generators is a function of tissue impedance, with the power ramping down as impedance either decreases toward zero or increases significantly to several thousand ohms. Current dry tip electrosurgical devices are not configured to address a change in power provided by the generator as tissue impedance changes or the associated effect on tissue and rely on the surgeon's expertise to overcome this limitation.

One medical condition which employs RF energy in treatment is gastrointestinal (GI) bleeding, with such treatment typically administered via gastrointestinal endoscopy. Bleeding in the upper gastrointestinal tract may result from, for example, peptic ulcers, gastritis, gastric cancer, vascular malformations such as varices (e.g. esophageal) and other lesions. Bleeding in the lower gastrointestinal tract may result from, for example, vascular malformations such as hemorrhoidal varices.

Peptic ulcer bleeding is one of the most common types of non-variceal upper gastrointestinal bleeding. Peptic ulcer bleeding results from the combined action of pepsin and hydrochloric acid in the gastric or digestive juices of the stomach. Peptic ulcers further include, for example, gastric ulcers, an eroded area in the lining (gastric mucosa) of the stomach, and duodenal ulcers, an eroded area in the lining (duodenal mucosa) of the duodenum. Peptic ulcers may also be found in Meckel's diverticulum.

Endoscopic modalities for the treatment of upper gastrointestinal bleeding include injection therapy (e.g. diluted epinephrine, sclerosants, thrombogenic substances, fibrin sealant), mechanical clips and so called thermal (heating) methods. Thermal methods are often divided into so called non-contact thermal methods and contact thermal methods. Non-contact thermal methods include laser treatment and, more recently, argon plasma coagulation (APC). Thermal contact methods include multipolar electrocoagulation and thermal coagulation probes.

Non-contact thermal probe methods depend on the heating of tissue protein, contraction of the arterial wall and vessel shrinkage. One drawback of non-contact

thermal methods is the "heat sink effect" where flowing arterial blood leads to dissipation of the thermal energy. Because of the greater tissue penetration, the neodymium: yttrium aluminum garnet (Nd:YAG) laser is generally superior to the argon laser for ulcer hemostasis. In any event, laser units are expensive, bulky and generally not portable. They are also difficult to use as an en face view of the bleeding ulcer is often required. For these reasons, laser photocoagulation has generally fallen out of favor for the treatment of ulcer bleeding. The argon plasma coagulator uses a flowing stream of argon gas as the conductor for electrocoagulation. This method is generally effective for mucosal bleeding but may not be effective in coagulating an eroded artery in a bleeding ulcer. Also, as flowing gas is required, care must be taken to avoid overdilatation of the stomach during treatment.

Contact thermal probes utilize the principle of "coaptive coagulation". First, mechanical pressure is applied to the bleeding vessel to compress the vessel before heat or electrical energy is applied to seal the bleeding vessel. Compression of the blood vessel also reduces the blood flow and reduces the heat sink effect. Multiple pulses of energy are given to coagulate the bleeding vessel to achieve hemostasis. These methods are effective in hemostasis but carry a potential risk of inducing bleeding when an adherent probe is pulled off a bleeding vessel. Furthermore, contact devices require accurate targeting of the bleeding vessel for successful ulcer hemostasis.

Multipolar electrocoagulation devices include the BICAP® Hemostasis Probe from ACMI Circon (300 Stillwater Avenue, Stamford, CT 06902) and the Gold Probe™ from Microvasive (480 Pleasant Street, Watertown, MA 02172). A third multipolar electrocoagulation device is the Injector-Gold Probe™, also from Microvasive, which incorporates an injection needle for use with epinephrine.

According to Dr. Joseph Leung's publication entitled "Endoscopic Management of Peptic Ulcer Bleeding", an "ideal" endoscopic hemostatic device should have the following properties. It should be effective in hemostasis, safe, inexpensive, easy to apply and portable. Thus, cost and non-portability issues associated with laser therapy have generally made it a less favorable treatment for ulcer hemostasis. Consequently, electrocoagulation or thermal coagulation have largely replaced laser therapy as a more routine treatment. Injection therapy generally has an advantage over the above contact thermal devices in that the injection does not need to be very accurate and can be performed through a pool of blood, but the cost of the medication is a disadvantage.

Turning to the argon plasma coagulator, according to in the publication "A Randomized Prospective Study of Endoscopic Hemostasis with Argon Plasma

Coagulator (APC) Compared to Gold Probe™ (GP) for Bleeding GI Angiomas”, Jutabha and colleagues compared the efficacy and safety of APC and GP for hemostasis of bleeding GI angiomas and describe the advantages and disadvantages of each type of treatment for angioma patients. Thirty-four patients with angiomas as the cause of acute or chronic GI bleeding, not responsive to iron supplementation alone, were stratified by syndrome (i.e., UGI, LGI angiomas; watermelon stomach; jejunal angiomas; radiation telangiectasia) and randomized to treatment in a prospective study: 16 to APC and 18 to GP.

According to the publication, there were 2 major complications of APC. While there were no significant differences between most clinical outcomes of APC versus GP patients, investigators observed that APC was significantly slower than GP and more difficult to use because of several features of APC: it could not coagulate through blood or water, smoke was common which interfered with visualization and increased gut motility, tamponade of bleeders was not possible, and tangential coagulation was difficult or often blind.

The differences between APC and GP were more marked with multiple angioma syndromes. Although APC is a "no touch technique," the catheter was difficult to hold 2-3 mm off the mucosa, which affords the best coagulation of a dry field. These features resulted in 6 failures and crossovers with APC and none with GP. There were no major disadvantages of GP except that coagulum needed to be cleaned off the tip after treatment of multiple angiomas. The authors concluded that for hemostasis of bleeding angiomas, both the APC and GP were effective, but there were substantial problems with the newer APC device, and overall the GP performed better.

In light of the above, what is needed is an endoscopic hemostatic device which offers advantages of both the so called non-contact and contact devices and methods without associated disadvantages. Thus, for example, what is needed is an endoscopic hemostatic device which is preferably portable and inexpensive. Furthermore, preferably the device should be capable of tissue contact and tamponage associated with coaptive coagulation to reduce the heat sink effect and facilitate treatment of an eroded artery, but be less likely to induce bleeding when the device is removed from a treated vessel. Furthermore, preferably the device should be capable of coagulation through blood or water (i.e. without contact) as well as tangential coagulation, without generating smoke which raises possible problems of visualization, gut motility or stomach overdistention. Furthermore, preferably the device should be capable of generating tissue hemostasis at a temperature high enough to result in tissue shrinkage, but at a temperature low enough not to necessarily create char (e.g. dried blood) formation or produce scabs,

which maybe subsequently dissolved by digestive juices a result in rebleeding. Furthermore, preferably the device should be capable of use on any surface of the GI tract without regard for orientation. In other words, for example, preferably the device may be used to treat any surface of the stomach, whether above, below or to  
5 the side.

### **Summary of the Invention**

According to one aspect of the invention, an electrosurgical device and methods for use are provided which comprises an electrosurgical device outer  
10 surface and includes a probe body, at least one conductor pair comprising a first electrode separated by a gap from a second electrode, and means in fluid communication with the lumen of a tube for distributing a fluid provided from the lumen of the tube to at least a portion of the surface of the electrosurgical device.

Also according to the invention, a catheter assembly is provided which  
15 comprises a catheter having a distal end and a lumen, and an electrosurgical device assembled with the catheter adjacent the distal end thereof. The electrosurgical device comprises an electrosurgical device outer surface and includes a probe body, at least one conductor pair comprising a first electrode separated by a gap from a second electrode, and means in fluid communication with the lumen of the catheter for  
20 distributing a fluid provided from the lumen of the catheter to at least a portion of the surface of the electrosurgical device.

According to another embodiment of the invention, a catheter assembly is provided which comprises a catheter having a distal end and a lumen, and an electrosurgical device assembled with the catheter adjacent the distal end thereof.  
25 The electrosurgical device comprises an electrosurgical device outer surface and includes a probe body, at least one conductor pair comprising a first electrode separated by a gap from a second electrode, and a fluid flow manifold located within the probe body. The fluid flow manifold includes at least one flow passage extending longitudinally within the probe body and at least one flow passage lateral  
30 to the longitudinal flow passage. The longitudinal flow passage comprises a longitudinal flow passage fluid entrance opening in fluid communication with the lumen of the catheter and is at least partially defined distally by an occlusion. The lateral flow passage in fluid communication with the longitudinal flow passage and extends through the probe body from the longitudinal flow passage towards the  
35 electrosurgical device outer surface.

According to another embodiment of the invention, a catheter assembly is provided which comprises a catheter, the catheter having a distal end and a lumen, and an electrosurgical device assembled with the catheter adjacent the distal end

thereof. The electrosurgical device comprises an electrosurgical device outer surface and includes a probe body, at least one conductor pair, the conductor pair comprising a first electrode separated by a gap from a second electrode, and means in fluid communication with the lumen of the catheter for distributing a fluid  
5 provided from the lumen of the catheter to at least a portion of the surface of the electrosurgical device.

According to another embodiment of the invention, a medical device is provided which comprises a catheter tube having a distal end and a lumen, and configured to assist in applying tamponage to a bleeding source in a gastrointestinal tract when flexed. A catheter tip having a catheter tip outer surface is assembled  
10 with the tube adjacent the distal end of the tube. The catheter tip comprises a probe body comprising an electrically insulative material, at least one electrode pair located on the probe body which comprises a first electrode spaced from a second electrode, and a fluid distribution manifold to direct a fluid from inside the probe  
15 body towards the tip outer surface. The manifold comprises a central passage within the probe body and a plurality of lateral passages which extend from the central passage towards the tip outer surface. An extendable injection needle is housed within the central passage to provide treatment to tissue.

20

### **Brief Description Of The Drawings**

FIG. 1 is a block diagram showing one embodiment of a control system of the invention, and an electrosurgical device;

FIG. 2 is a schematic graph that describes the relationship between RF power to tissue (P), flow rate of saline (Q), and tissue temperature (T) when heat  
25 conduction to adjacent tissue is considered;

FIG. 2A is a schematic graph that describes the relationship between RF power to tissue (P), flow rate of saline (Q), and tissue temperature (T) when the heat required to warm the tissue to the peak temperature (T) 68 is considered;

FIG. 3 is schematic graph that describes the relationship between RF power  
30 to tissue (P), flow rate of saline (Q), and tissue temperature (T) when heat conduction to adjacent tissue is neglected;

FIG. 4 is a graph showing the relationship of percentage saline boiling and saline flow rate (cc/min) for an exemplary RF generator output of 75 watts;

FIG. 5 is a schematic graph that describes the relationship of load impedance  
35 (Z, in ohms) and generator output power (P, in watts), for an exemplary generator output of 75 watts in a bipolar mode;

FIG. 6 is a schematic graph that describes the relationship of time (t, in seconds) and tissue impedance (Z, in ohms) after RF activation;



FIG. 7 is a schematic perspective view of a viewing scope with an electrosurgical device according to one embodiment of the invention;

FIG. 8 is a schematic close-up view of the distal end portion of the viewing scope of FIG. 7 bounded by circle A with an electrosurgical device according to one embodiment of the invention;

FIG. 9 is a schematic close-up front perspective view of an electrosurgical device according to one embodiment of the invention;

FIG. 10 is a schematic partially exploded close-up rear perspective view of the electrosurgical device of FIG. 9;

FIG. 11 is a schematic close-up side view of the electrosurgical device of FIG. 9 as part of a medical device assembly;

FIG. 12 is a schematic close-up cross-sectional view of the assembly of FIG. 11 taken in accordance with line 12-12 of FIG. 13;

FIG. 13 is a schematic close-up front view of the electrosurgical device of FIG. 9;

FIG. 14 is a schematic close-up rear view of the electrosurgical device of FIG. 9 with member 51 removed;

FIG. 15 is a schematic close-up cross-sectional view of the electrosurgical device of FIG. 9 taken in accordance with line 15-15 of FIG. 12;

FIG. 16 is a schematic close-up cross-sectional view of the electrosurgical device of FIG. 9 taken in accordance with line 16-16 of FIG. 12;

FIG. 17 is a schematic close-up front perspective view of an electrosurgical device according to another embodiment of the invention;

FIG. 18 is a schematic close-up cross-sectional view of the assembly of the electrosurgical device of FIG. 17 and tube 19 taken in accordance with line 12-12 of FIG. 13;

FIG. 19 is a schematic close-up cross-sectional view of the electrosurgical device of FIG. 17 taken in accordance with line 19-19 of FIG. 18;

FIG. 20 is a schematic close-up front perspective view of an electrosurgical device according to another embodiment of the invention;

FIG. 21 is a schematic close-up cross-sectional view of the assembly of the electrosurgical device of FIG. 20 and tube 19 taken in accordance with line 12-12 of FIG. 13;

FIG. 22 is a schematic close-up cross-sectional view of the electrosurgical device of FIG. 20 taken in accordance with line 22-22 of FIG. 21;

FIG. 23 is a schematic close-up partial cross-sectional view of an electrosurgical device according to another embodiment of the invention taken in accordance with line 22-22 of FIG. 21;

FIG. 24 is a schematic close-up cross-sectional view of the assembly of an electrosurgical device according to another embodiment of the invention and tube 19 taken in accordance with line 12-12 of FIG. 13;

5 FIG. 25 is a schematic close-up partial cross-sectional view of an electrosurgical device according to another embodiment of the invention taken in accordance with line 22-22 of FIG. 21;

FIG. 26 is a schematic close-up partial cross-sectional view of an electrosurgical device according to another embodiment of the invention taken in accordance with line 22-22 of FIG. 21;

10 FIG. 27 is a schematic close-up partial cross-sectional view of an electrosurgical device according to another embodiment of the invention taken in accordance with line 22-22 of FIG. 21;

FIG. 28 is a schematic close-up partial cross-sectional view of an electrosurgical device according to another embodiment of the invention taken in accordance with line 22-22 of FIG. 21;

15 FIG. 29 is a schematic close-up front perspective view of an electrosurgical device according to another embodiment of the invention;

FIG. 30 is a schematic close-up cross-sectional view of the assembly of the electrosurgical device of FIG. 29 and tube 19 taken in accordance with line 12-12 of FIG. 13;

FIG. 31 is a schematic close-up cross-sectional view of the electrosurgical device of FIG. 29 taken in accordance with line 31-31 of FIG. 30;

FIG. 32 is a schematic close-up front perspective view of the electrosurgical device of FIG. 29 with instrument 64 extended;

25 FIG. 33 is a schematic close-up cross-sectional view of the assembly of FIG. 30 with instrument 64 extended;

FIG. 34 is a schematic close-up front perspective view of an electrosurgical device according to another embodiment of the invention;

30 FIG. 35 is a schematic close-up cross-sectional view of the assembly of the electrosurgical device of FIG. 34 and tube 19 taken in accordance with line 12-12 of FIG. 13;

FIG. 36 is a schematic close-up cross-sectional view of the electrosurgical device of FIG. 34 taken in accordance with line 36-36 of FIG. 35;

35 FIG. 37 is a schematic close-up front perspective view of an electrosurgical device according to another embodiment of the invention;

FIG. 38 is a schematic close-up cross-sectional view of the electrosurgical device of FIG. 37 taken in accordance with line 38-38 of FIG. 39;

FIG. 39 is a schematic close-up cross-sectional view of the assembly of the electrosurgical device of FIG. 37 with instrument 64 and tube 19 taken in accordance with line 12-12 of FIG. 13;

5 FIG. 40 is a schematic close-up cross-sectional view of the assembly of the electrosurgical device of FIG. 37 with instrument 73 and tube 19 taken in accordance with line 12-12 of FIG. 13;

FIG. 41 is a schematic close-up front perspective view of an electrosurgical device according to another embodiment of the invention;

10 FIG. 42 is a schematic close-up cross-sectional view of the assembly of the electrosurgical device of FIG. 41 and tube 19 taken in accordance with line 12-12 of FIG. 13;

FIG. 43 is a schematic close-up cross-sectional view of the electrosurgical device of FIG. 42 taken in accordance with line 43-43 of FIG. 42;

15 FIG. 44 is a schematic close-up front perspective view of an electrosurgical device according to another embodiment of the invention;

FIG. 45 is a schematic close-up rear perspective view of the electrosurgical device of FIG. 44 with member 51 removed;

20 FIG. 46 is a schematic close-up cross-sectional view of the assembly of the electrosurgical device of FIG. 44 and tube 19 taken in accordance with line 12-12 of FIG. 13;

FIG. 47 is a schematic close-up cross-sectional view of the electrosurgical device of FIG. 44 taken in accordance with line 47-47 of FIG. 46;

FIG. 48 is a schematic close-up front perspective view of an electrosurgical device according to another embodiment of the invention;

25 FIG. 49 is a schematic close-up cross-sectional view of the assembly of the electrosurgical device of FIG. 48 and tube 19 taken in accordance with line 12-12 of FIG. 13;

FIG. 50 is a schematic close-up cross-sectional view of the electrosurgical device of FIG. 48 taken in accordance with line 50-50 of FIG. 49;

30 FIG. 51 is a schematic close-up front perspective view of an electrosurgical device according to another embodiment of the invention;

FIG. 52 is a schematic close-up cross-sectional view of the assembly of the electrosurgical device of FIG. 51 and tube 19 taken in accordance with line 12-12 of FIG. 13;

35 FIG. 53 is a schematic close-up cross-sectional view of the electrosurgical device of FIG. 51 taken in accordance with line 53-53 of FIG. 52;

FIG. 54 is a schematic exploded perspective view of an assembly of an electrosurgical device according to another embodiment of the invention and a handle 100;

FIG. 55 is the schematic close-up up cross-sectional view of FIG. 53 shown with tissue 20 and with fluid 24;

FIG. 56 is the schematic close-up up cross-sectional view of FIG. 21 shown with tissue 20 and with fluid 24;

FIG. 57 is a schematic close-up front perspective view of an electrosurgical device according to another embodiment of the invention;

FIG. 58 is a schematic close-up rear perspective view of the electrosurgical device of FIG. 57 with member 51 removed;

FIG. 59 is a schematic close-up cross-sectional view of the assembly of the electrosurgical device of FIG. 57 and tube 19 taken in accordance with line 12-12 of FIG. 13;

FIG. 60 is a schematic close-up cross-sectional view of the electrosurgical device of FIG. 57 taken in accordance with line 60-60 of FIG. 59;

FIG. 61 is a schematic close-up front perspective view of an electrosurgical device according to another embodiment of the invention;

FIG. 62 is a schematic close-up rear perspective view of the electrosurgical device of FIG. 61 with member 51 removed;

FIG. 63 is a schematic close-up cross-sectional view of the assembly of the electrosurgical device of FIG. 61 and tube 19 taken in accordance with line 12-12 of FIG. 13;

FIG. 64 is a schematic close-up cross-sectional view of the assembly of the electrosurgical device of FIG. 61 and tube 19 taken at 90 degrees to line 12-12 of FIG. 13; and

FIG. 65 is a schematic close-up cross-sectional view of the electrosurgical device of FIG. 61 taken in accordance with line 65-65 of FIG. 63.

30

### **Detailed Description**

Throughout the present description, like reference numerals and letters indicate corresponding structure throughout the several views, and such corresponding structure need not be separately discussed. Furthermore, any particular feature(s) of a particular exemplary embodiment may be equally applied to any other exemplary embodiment(s) of this specification as suitable. In other words, features between the various exemplary embodiments described herein are interchangeable as suitable, and not exclusive.

The invention provides systems, devices and methods that preferably improve control of tissue temperature at a tissue treatment site during a medical procedure. The invention is particularly useful during surgical procedures upon tissues of the body, where it is desirable to shrink tissue, coagulate fluids (e.g. oozing blood), and at least partially occlude lumens, vessels (e.g. lumen of blood vessels (e.g. arteries, veins), intestines (e.g. absorbent vessels)) and airways (e.g. trachea, bronchi, bronchiole)).

The invention preferably involves the use of electrosurgical procedures, which preferably utilize RF power and electrically conductive fluid to treat tissue. Preferably, a desired tissue temperature range is achieved through adjusting parameters, such as conductive fluid flow rate, that affect the temperature at the tissue/electrode interface. Preferably, the device achieves a desired tissue temperature utilizing a desired percentage boiling of the conductive solution at the tissue/electrode interface.

In one embodiment, the invention provides a control device, the device comprising a flow rate controller that receives a signal indicating power applied to the system, and adjusts the flow rate of conductive fluid from a fluid source to an electrosurgical device. The invention also contemplates a control system comprising a flow rate controller, a measurement device that measures power applied to the system, and a pump that provides fluid at a selected flow rate.

The invention will be discussed generally with reference to FIG. 1. FIG. 1 shows a block diagram of one exemplary embodiment of a system of the invention. Preferably, as shown in FIG. 1, an electrically conductive fluid is provided from a fluid source 1, through a fluid line 2, to a pump 3, which has an outlet fluid line 4a that is connected as an input fluid line 4b to electrosurgical device 5. In a preferred embodiment, the outlet fluid line 4a and the input fluid line 4b are flexible and comprise a polymer, such as polyvinylchloride (PVC), while the conductive fluid comprises a saline solution. More preferably, the saline comprises sterile, and even more preferably, normal saline. Although the description herein will specifically describe the use of saline as the fluid, other electrically conductive fluids, as well as non-conductive fluids, can be used in accordance with the invention.

For example, in addition to the conductive fluid comprising physiologic saline (also known as "normal" saline, isotonic saline or 0.9% sodium chloride (NaCl) solution), the conductive fluid may comprise hypertonic saline solution, hypotonic saline solution, Ringers solution (a physiologic solution of distilled water containing specified amounts of sodium chloride, calcium chloride, and potassium chloride), lactated Ringer's solution (a crystalloid electrolyte sterile solution of distilled water containing specified amounts of calcium chloride, potassium chloride,

sodium chloride, and sodium lactate), Locke-Ringer's solution (a buffered isotonic solution of distilled water containing specified amounts of sodium chloride, potassium chloride, calcium chloride, sodium bicarbonate, magnesium chloride, and dextrose), or any other electrolyte solution. In other words, a solution that conducts  
5 electricity via an electrolyte, a substance (salt, acid or base) that dissociates into electrically charged ions when dissolved in a solvent, such as water, resulting solution comprising an ionic conductor.

While a conductive fluid is preferred, as will become more apparent with further reading of this specification, the fluid may also comprise an electrically non-  
10 conductive fluid. The use of a non-conductive fluid is less preferred to that of a conductive fluid as the non-conductive fluid does not conduct electricity. However, the use of a non-conductive fluid still provides certain advantages over the use of a dry electrode including, for example, reduced occurrence of tissue sticking to the electrode. Therefore, it is also within the scope of the invention to include the use of  
15 a non-conducting fluid, such as, for example, dionized water.

Energy to heat tissue is provided from energy source, such as an electrical generator **6** which preferably provides RF alternating current energy via a cable **7** to energy source output measurement device, such as a power measurement device **8** that measures the RF alternating current electrical power. In one exemplary  
20 embodiment, preferably the power measurement device **8** does not turn the power off or on, or alter the power in any way. A power switch **15** connected to the generator **6** is preferably provided by the generator manufacturer and is used to turn the generator **6** on and off. The power switch **15** can comprise any switch to turn the power on and off, and is commonly provided in the form of a footswitch or other  
25 easily operated switch, such as a switch **15a** mounted on the electrosurgical device **5**. The power switch **15** or **15a** may also function as a manually activated device for increasing or decreasing the rate of energy provided from the surgical device **5**. Alternatively, internal circuitry and other components of the generator **6** may be used for automatically increasing or decreasing the rate of energy provided from the  
30 surgical device **5**. A cable **9** preferably carries RF energy from the power measurement device **8** to the electrosurgical device **5**. Power, or any other energy source output, is preferably measured before it reaches the electrosurgical device **5**.

For the situation where capacitation and induction effects are negligibly small, from Ohm's law, power **P**, or the rate of energy delivery (e.g. joules/sec),  
35 may be expressed by the product of current times voltage (i.e.  $I \times V$ ), the current squared times resistance (i.e.  $I^2 \times R$ ), or the voltage squared divided by the resistance (i.e.  $V^2/R$ ); where the current **I** may be measured in amperes, the voltage **V** may be measured in volts, the electrical resistance **R** may be measured in ohms, and the

power **P** may be measured in watts (joules/sec). Given that power **P** is a function of current **I**, voltage **V**, and resistance **R** as indicated above, it should be understood, that a change in power **P** is reflective of a change in at least one of the input variables. Thus, one may alternatively measure changes in such input variables themselves, rather than power **P** directly, with such changes in the input variables mathematically corresponding to a changes in power **P** as indicated above.

As to the frequency of the RF electrical energy, it is preferably provided within a frequency band (i.e. a continuous range of frequencies extending between two limiting frequencies) in the range between and including about 9 kHz (kilohertz) to 300 GHz (gigahertz). More preferably, the RF energy is provided within a frequency band in the range between and including about 50 kHz (kilohertz) to 50 MHz (megahertz). Even more preferably, the RF energy is provided within a frequency band in the range between and including about 200 kHz (kilohertz) to 2 MHz (megahertz). Most preferably, RF energy is provided within a frequency band in the range between and including about 400 kHz (kilohertz) to 600 kHz (kilohertz). Further, it should also be understood that, for any frequency band identified above, the range of frequencies may be further narrowed in increments of 1 (one) hertz anywhere between the lower and upper limiting frequencies.

While RF electrical energy is preferred, it should be understood that the electrical energy (i.e., energy made available by the flow of electric charge, typically through a conductor or by self-propagating waves) may comprise any frequency of the electromagnetic spectrum (i.e. the entire range of radiation extending in frequency from  $10^{23}$  hertz to 0 hertz) and including, but not limited to, gamma rays, x-rays, ultraviolet radiation, visible light, infrared radiation, microwaves, and any combinations thereof.

With respect to the use of electrical energy, heating of the tissue is preferably performed by means of resistance heating. In other words, increasing the temperature of the tissue as a result of electric current flow through the tissue, with the electrical energy being absorbed from the voltage and transformed into thermal energy (i.e. heat) via accelerated movement of ions as a function of the tissue's electrical resistance.

Heating with electrical energy may also be performed by means of dielectric heating (capacitation). In other words, increasing the temperature of the tissue through the dissipation of electrical energy as a result of internal dielectric loss when the tissue is placed in a varying electric field, such as a high-frequency (e.g. microwave), alternating electromagnetic field. Dielectric loss is the electrical energy lost as heat in the polarization process in the presence of the applied electric field. In the case of an alternating current field, the energy is absorbed from the

alternating current voltage and converted to heat during the polarization of the molecules.

However, it should be understood that energy provided to heat the tissue may comprise surgical devices other than electrosurgical devices, energy sources other than generators, energy forms other than electrical energy and mechanisms other than resistance heating. For example, providing thermal energy to the tissue from energy source with a difference (e.g. higher) in temperature. Such may be provided, for example, to the tissue from a heated device, which heats tissue through direct contact with the energy source (conduction), heats through contact with a flowing fluid (convection), or from a remote heat source (radiation).

Also, for example, providing energy to the tissue may be provided via mechanical energy which is transformed into thermal energy via accelerated movement of the molecules, such as by mechanical vibration provided, for example, by energy source such as a transducer containing a piezoelectric substance (e.g., a quartz-crystal oscillator) that converts high-frequency electric current into vibrating ultrasonic waves which may be used by, for example, an ultrasonic surgical device.

Also, for example, providing energy to the tissue may be provided via radiant energy (i.e. energy which is transmitted by radiation/waves) which is transformed into thermal energy via absorption of the radiant energy by the tissue. Preferably the radiation/waves comprise electromagnetic radiation/waves which include, but is not limited to, radio waves, microwaves, infrared radiation, visible light radiation, ultraviolet radiation, x-rays and gamma rays. More preferably, such radiant energy comprises energy with a frequency of  $3 \times 10^{11}$  hertz to  $3 \times 10^{16}$  hertz (i.e. the infrared, visible, and ultraviolet frequency bands of the electromagnetic spectrum). Also preferably the electromagnetic waves are coherent and the electromagnetic radiation is emitted from energy source such as a laser device. A flow rate controller 11 preferably includes a selection switch 12 that can be set to achieve desired levels of percentage fluid boiling (for example, 100%, 98%, 80% boiling). Preferably, the flow rate controller 11 receives an input signal 10 from the power measurement device 8 and calculates an appropriate mathematically predetermined fluid flow rate based on percentage boiling indicated by the selection switch 12. In a preferred embodiment, a fluid switch 13 is provided so that the fluid system can be primed (e.g. air eliminated) before turning the generator 6 on. The output signal 16 of the flow rate controller 11 is preferably sent to the pump 3 motor to regulate the flow rate of conductive fluid, and thereby provide an appropriate fluid flow rate which corresponds to the amount of power being delivered.

In one exemplary embodiment, the invention comprises a flow rate controller that is configured and arranged to be connected to a source of RF power, and a



source of fluid, for example, a source of conductive fluid. The device of the invention receives information about the level of RF power applied to an electrosurgical device, and adjusts the flow rate of the fluid to the electrosurgical device, thereby controlling temperature at the tissue treatment site.

5           In another exemplary embodiment, elements of the system are physically included together in one electronic enclosure. One such embodiment is shown by enclosure within the outline box 14 of FIG 1. In the illustrated embodiment, the pump 3, flow rate controller 11, and power measurement device 8 are enclosed within an enclosure, and these elements are connected through electrical connections  
10 to allow signal 10 to pass from the power measurement device 8 to the flow rate controller 11, and signal 16 to pass from the flow rate controller 11 to the pump 3. Other elements of a system can also be included within one enclosure, depending upon such factors as the desired application of the system, and the requirements of the user.

15           The pump 3 can be any suitable pump used in surgical procedures to provide saline or other fluid at a desired flow rate. Preferably, the pump 3 comprises a peristaltic pump. With a rotary peristaltic pump, typically a fluid is conveyed within the confines of a flexible tube by waves of contraction placed externally on the tube which are produced mechanically, typically by rotating rollers which squeeze the  
20 flexible tubing against a support intermittently. Alternatively, with a linear peristaltic pump, typically a fluid is conveyed within the confines of a flexible tube by waves of contraction placed externally on the tube which are produced mechanically, typically by a series of compression fingers or pads which squeeze the flexible tubing against a support sequentially. Peristaltic pumps are generally  
25 preferred for use as the electro-mechanical force mechanism (e.g. rollers driven by electric motor) does not make contact the fluid, thus reducing the likelihood of inadvertent contamination.

          Alternatively, pump 3 can be a "syringe pump", with a built-in fluid supply. With such a pump, typically a filled syringe is located on an electro-mechanical  
30 force mechanism (e.g. ram driven by electric motor) which acts on the plunger of the syringe to force delivery of the fluid contained therein. Alternatively, the syringe pump may comprise a double-acting syringe pump with two syringes such that they can draw saline from a reservoir, either simultaneously or intermittently. With a double acting syringe pump, the pumping mechanism is generally capable of both  
35 infusion and withdrawal. Typically, while fluid is being expelled from one syringe, the other syringe is receiving fluid therein from a separate reservoir. In this manner, the delivery of fluid remains continuous and uninterrupted as the syringes function in series. Alternatively, it should be understood that a multiple syringe pump with

two syringes, or any number of syringes, may be used in accordance with the invention.

Furthermore, fluid, such as conductive fluid, can also be provided from an intravenous (IV) bag full of saline that flows under the influence (i.e. force) of gravity. In such a manner, the fluid may flow directly to the electrosurgical device **5**, or first to the pump **3** located there between. Alternatively, fluid from a fluid source such as an IV bag can be provided through an IV flow controller that may provide a desired flow rate by adjusting the cross sectional area of a flow orifice (e.g. lumen of the connective tubing with the electrosurgical device) while sensing the flow rate with a sensor such as an optical drop counter. Furthermore, fluid from a fluid source such as an IV bag can be provided through a manually or automatically activated device such as a flow controller, such as a roller clamp, which also adjusts the cross sectional area of a flow orifice and may be adjusted manually by, for example, the user of the device in response to their visual observation (e.g. fluid boiling) at the tissue treatment site or a pump.

Similar pumps can be used in connection with the invention, and the illustrated embodiments are exemplary only. The precise configuration of the pump **3** is not critical to the invention. For example, pump **3** may include other types of infusion and withdrawal pumps. Furthermore, pump **3** may comprise pumps which may be categorized as piston pumps, rotary vane pumps (e.g. blower, axial impeller, centrifugal impeller), cartridge pumps and diaphragm pumps. In some embodiments, the pump can be substituted with any type of flow controller, such as a manual roller clamp used in conjunction with an IV bag, or combined with the flow controller to allow the user to control the flow rate of conductive fluid to the device. Alternatively, a valve configuration can be substituted for pump **3**.

Furthermore, similar configurations of the system can be used in connection with the invention, and the illustrated embodiments are exemplary only. For example, the fluid source **1**, pump **3**, generator **6**, power measurement device **8** or flow rate controller **11**, or any other components of the system not expressly recited above, may comprise a portion of the electrosurgical device **5**. For example, in one exemplary embodiment the fluid source may comprise a compartment of the electrosurgical device **5** which contains fluid, as indicated at reference character **1a**. In another exemplary embodiment, the compartment may be detachably connected to the electrosurgical device **5**, such as a canister which may be attached via threaded engagement with the device **5**. In yet another exemplary embodiment, the compartment may be configured to hold a pre-filled cartridge of fluid, rather than the fluid directly.

Also for example, with regards to the generator, energy source, such as a direct current (DC) battery used in conjunction with inverter circuitry and a transformer to produce alternating current at a particular frequency, may comprise a portion of the electrosurgical device 5, as indicated at reference character 6a. In one  
 5 embodiment the battery element of the energy source may comprise a rechargeable battery. In yet another exemplary embodiment, the battery element may be detachably connected to the electrosurgical device 5, such as for recharging. The components of the system will now be described in further detail. From the specification, it should be clear that any use of the terms "distal" and "proximal" are  
 10 made in reference from the user of the device, and not the patient.

The flow rate controller 11 controls the rate of flow from the fluid source 1. Preferably, the rate of fluid flow from the fluid source 1 is based upon the amount of RF power provided from the generator 6 to the electrosurgical device 5. In other words, as shown in FIG. 2, preferably there is a relationship between the rate of fluid  
 15 flow and the RF power as indicated by the X- and Y-axes of the schematic graph. More precisely, as shown in FIG. 2, the relationship between the rate of fluid flow and RF power may be expressed as a direct, linear relationship. The flow rate of conductive fluid, such as saline, interacts with the RF power and various modes of heat transfer away from the target tissue, as described herein.

Throughout this disclosure, when the terms "boiling point of saline",  
 20 "vaporization point of saline", and variations thereof are used, what is intended is the boiling point of the water in the saline solution.

FIG. 2 shows a schematic graph that describes the relationship between the flow rate of saline, RF power to tissue, and regimes of boiling as detailed below.  
 25 Based on a simple one-dimensional lumped parameter model of the heat transfer, the peak tissue temperature can be estimated, and once tissue temperature is estimated, it follows directly whether it is hot enough to boil saline.

$$P = \Delta T/R + \rho c_p Q_l \Delta T + \rho Q_b h_v \quad (1)$$

30

where P = the total RF electrical power that is converted into heat.

Conduction. The first term  $[\Delta T/R]$  in equation (1) is heat conducted to adjacent tissue, represented as 70 in FIG. 2, where:

35

$\Delta T = (T - T_\infty)$  the difference in temperature between the peak tissue temperature (T) and the normal temperature ( $T_\infty$ ) of the body tissue ( $^\circ\text{C}$ ). Normal temperature of the body tissue is generally  $37\text{ }^\circ\text{C}$ ; and

R = Thermal resistance of surrounding tissue, the ratio of the temperature difference to the heat flow ( $^{\circ}\text{C}/\text{watt}$ ).

5 This thermal resistance can be estimated from published data gathered in experiments on human tissue (Phipps, J.H., "Thermometry studies with bipolar diathermy during hysterectomy," *Gynaecological Endoscopy*, 3:5-7 (1994)). As described by Phipps, Kleppinger bipolar forceps were used with an RF power of 50 watts, and the peak tissue temperature reached  $320^{\circ}\text{C}$ . For example, using the  
10 energy balance of equation (1), and assuming all the RF heat put into tissue is conducted away, then R can be estimated:

$$R = \Delta T/P = (320-37)/50 = 5.7 \approx 6^{\circ}\text{C}/\text{watt}$$

15 However, it is undesirable to allow the tissue temperature to reach  $320^{\circ}\text{C}$ , since tissue will become desiccated. At a temperature of  $320^{\circ}\text{C}$ , the fluid contained in the tissue is typically boiled away, resulting in the undesirable tissue effects described herein. Rather, it is preferred to keep the peak tissue temperature at no more than about  $100^{\circ}\text{C}$  to inhibit desiccation of the tissue. Assuming that saline  
20 boils at about  $100^{\circ}\text{C}$ , the first term in equation (1) ( $\Delta T/R$ ) is equal to  $(100 - 37)/6 = 10.5$  watts. Thus, based on this example, the maximum amount of heat conducted to adjacent tissue without any significant risk of tissue desiccation is 10.5 watts.

Referring to FIG. 2, RF power to tissue is represented on the X-axis as **P** (watts) and flow rate of saline (cc/min) is represented on the Y-axis as **Q**. When the  
25 flow rate of saline equals zero ( $Q = 0$ ), there is an "offset" RF power that shifts the origin of the sloped lines **76**, **78**, and **80** to the right. This offset is the heat conducted to adjacent tissue. For example, using the calculation above for bipolar forceps, this offset RF power is about 10.5 watts. If the power is increased above this level with no saline flow, the peak tissue temperature can rise well above  $100^{\circ}\text{C}$ ,  
30 resulting in tissue desiccation from the boiling off of water in the cells of the tissue.

Convection. The second term  $[\rho c_p Q_1 \Delta T]$  in equation (1) is heat used to warm up the flow of saline without boiling the saline, represented as **72** in FIG. 2, where:

35  $\rho =$  Density of the saline fluid that gets hot but does not boil (approximately  $1.0 \text{ gm}/\text{cm}^3$ );

$c_p =$  Specific heat of the saline (approximately  $4.1 \text{ watt-sec}/\text{gm-}^{\circ}\text{C}$ );

$Q_1 =$  Flow rate of the saline that is heated ( $\text{cm}^3/\text{sec}$ ); and

$\Delta T =$  Temperature rise of the saline. Assuming that the saline is heated to body temperature before it gets to the electrode, and that the peak saline temperature is similar to the peak tissue temperature, this is the same  $\Delta T$  as for the conduction calculation above.

5

The onset of boiling can be predicted using equation (1) with the last term on the right set to zero (no boiling) ( $\rho Q_b h_v = 0$ ), and solving equation (1) for  $Q_l$  leads to:

$$Q_l = [P - \Delta T/R]/\rho c_p \Delta T \quad (2)$$

10

This equation defines the line shown in FIG. 2 as the line of onset of boiling 76.

Boiling. The third term [ $\rho Q_b h_v$ ] in equation (1) relates to heat that goes into converting the water in liquid saline to water vapor, and is represented as 74 in FIG. 2, where:

15

$Q_b =$  Flow rate of saline that boils ( $\text{cm}^3/\text{sec}$ ); and

$h_v =$  Heat of vaporization of saline (approximately 2,000 watt-sec/gm).

20

A flow rate of only 1 cc/min will absorb a significant amount of heat if it is completely boiled, or about  $\rho Q_b h_v = (1) (1/60) (2,000) = 33.3$  watts. The heat needed to warm this flow rate from body temperature to 100 °C is much less, or  $\rho c_p Q_l \Delta T = (1) (4.1) (1/60) (100 - 37) = 4.3$  watts. In other words, the most significant factor contributing to heat transfer from a wet electrode device can be fractional boiling. The present invention recognizes this fact and exploits it.

25

Fractional boiling can be described by equation (3) below:

$$Q_l = \frac{\{P - \Delta T/R\}}{\{\rho c_p \Delta T + \rho h_v Q_b/Q_l\}} \quad (3)$$

30

If the ratio of  $Q_b/Q_l$  is 0.50 this is the 50% boiling line 78 shown in FIG. 2. If the ratio is 1.0 this is the 100% boiling line 80 shown in FIG. 2.

As indicated previously in the specification, using a fluid to couple energy to tissue inhibits such undesirable effects as sticking, desiccation, smoke production and char formation, and that one key factor is inhibiting tissue desiccation, which occur if the tissue temperature exceeds 100 °C and all the intracellular water boils away, leaving the tissue extremely dry and much less electrically conductive.

35

As shown in FIG. 2, one control strategy or mechanism which can be employed for the electrosurgical device 5 is to adjust the power P and flow rate Q such that the power P used at a corresponding flow rate Q is equal to or less than the power P required to boil 100% of the fluid and does not exceed the power P required to boil 100% of the fluid. In other words, this control strategy targets using the electrosurgical device 5 in the regions of FIG. 2 identified as  $T < 100\text{ }^{\circ}\text{C}$  and  $T = 100\text{ }^{\circ}\text{C}$ , and includes the 100% boiling line 80. Stated another way, this control strategy targets not using the electrosurgical device 5 only in the region of FIG. 2 identified as  $T \gg 100\text{ }^{\circ}\text{C}$ .

Another control strategy that can be used for the electrosurgical device 5 is to operate the device 5 in the region  $T < 100\text{ }^{\circ}\text{C}$ , but at high enough temperature to shrink tissue containing Type I collagen (e.g., walls of blood vessels, bronchi, bile ducts, etc.), which shrinks when exposed to about  $85\text{ }^{\circ}\text{C}$  for an exposure time of 0.01 seconds, or when exposed to about  $65\text{ }^{\circ}\text{C}$  for an exposure time of 15 minutes. An exemplary target temperature/time for tissue shrinkage is about  $75\text{ }^{\circ}\text{C}$  with an exposure time of about 1 second. As discussed herein, a determination of the high end of the scale (i.e., when the fluid reaches  $100\text{ }^{\circ}\text{C}$ ) can be made by the phase change in the fluid from liquid to vapor. However, a determination at the low end of the scale (e.g., when the fluid reaches, for example,  $75\text{ }^{\circ}\text{C}$  for 1 second) requires a different mechanism as the temperature of the fluid is below the boiling temperature and no such phase change is apparent. In order to determine when the fluid reaches a temperature that will facilitate tissue shrinkage, for example  $75\text{ }^{\circ}\text{C}$ , a thermochromic material, such as a thermochromic dye (e.g., leuco dye), may be added to the fluid. The dye can be formulated to provide a first predetermined color to the fluid at temperatures below a threshold temperature, such as  $75\text{ }^{\circ}\text{C}$ , then, upon heating above  $75\text{ }^{\circ}\text{C}$ , the dye provides a second color, such as clear, thus turning the fluid clear (i.e. no color or reduction in color). This color change may be gradual, incremental, or instant. Thus, a change in the color of the fluid, from a first color to a second color (or lack thereof) provides a visual indication to the user of the electrosurgical device 5 as to when a threshold fluid temperature below boiling has been achieved. Thermochromic dyes are available, for example, from Color Change Corporation, 1740 Cortland Court, Unit A, Addison, IL 60101.

It is also noted that the above mechanism (i.e., a change in the color of the fluid due to a dye) may also be used to detect when the fluid reaches a temperature which will facilitate tissue necrosis; this generally varies from about  $60\text{ }^{\circ}\text{C}$  for an exposure time of 0.01 seconds and decreasing to about  $45\text{ }^{\circ}\text{C}$  for an exposure time of 15 minutes. An exemplary target temperature/time for tissue necrosis is about  $55\text{ }^{\circ}\text{C}$  for an exposure time of about 1 second.

In order to reduce coagulation time, use of the electrosurgical device **5** in the region  $T = 100\text{ }^{\circ}\text{C}$  of FIG. **2** is preferable to use of the electrosurgical device **5** in the region  $T < 100\text{ }^{\circ}\text{C}$ . Consequently, as shown in FIG. **2**, another control strategy which may be employed for the electrosurgical device **5** is to adjust the power **P** and flow rate **Q** such that the power **P** used at a corresponding flow rate **Q** is equal to or more than the power **P** required to initiate boiling of the fluid, but still less than the power **P** required to boil 100% of the fluid. In other words, this control strategy targets using the electrosurgical device **5** in the region of FIG. **2** identified as  $T = 100\text{ }^{\circ}\text{C}$ , and includes the lines of the onset of boiling **76** and 100% boiling line **80**. Stated another way, this control strategy targets use using the electrosurgical device **5** on or between the lines of the onset of boiling **76** and 100% boiling line **80**, and not using the electrosurgical device **5** in the regions of FIG. **2** identified as  $T < 100\text{ }^{\circ}\text{C}$  and  $T \gg 100\text{ }^{\circ}\text{C}$ .

For consistent tissue effect, it is desirable to control the saline flow rate so that it is always on a "line of constant % boiling" as, for example, the line of the onset of boiling **76** or the 100% boiling line **80** or any line of constant % boiling located in between (e.g. 50% boiling line **78**) as shown in FIG. **2**. Consequently, another control strategy that can be used for the electrosurgical device **5** is to adjust power **P** and flow rate **Q** such that the power **P** used at a corresponding flow rate **Q** targets a line of constant % boiling.

It should be noted, from the preceding equations, that the slope of any line of constant % boiling is known. For example, for the line of the onset of boiling **76**, the slope of the line is given by  $(\rho c_p \Delta T)$ , while the slope of the 100% boiling line **80** is given by  $1/(\rho c_p \Delta T + \rho h_v)$ . As for the 50% boiling line **78**, for example, the slope is given by  $1/(\rho c_p \Delta T + \rho h_v 0.5)$ .

If, upon application of the electrosurgical device **5** to the tissue, boiling of the fluid is not detected, such indicates that the temperature is less than  $100\text{ }^{\circ}\text{C}$  as indicated in the area of FIG. **2**, and the flow rate **Q** must be decreased to initiate boiling. The flow rate **Q** may then decreased until boiling of the fluid is first detected, at which time the line of the onset of boiling **76** is transgressed and the point of transgression on the line **76** is determined. From the determination of a point on the line of the onset of boiling **76** for a particular power **P** and flow rate **Q**, and the known slope of the line **76** as outlined above (i.e.  $1/\rho c_p \Delta T$ ), it is also possible to determine the heat conducted to adjacent tissue **70**.

Conversely, if upon application of the electrosurgical device **5** to the tissue, boiling of the fluid is detected, such indicates that the temperature is approximately equal to  $100\text{ }^{\circ}\text{C}$  as indicated in the areas of FIG. **2**, and the flow rate **Q** must be increased to reduce boiling until boiling stops, at which time the line of the onset of

boiling 76 is transgressed and the point of transgression on the line 76 determined. As with above, from the determination of a point on the line of the onset of boiling 76 for a particular power **P** and flow rate **Q**, and the known slope of the line 76, it is also possible to determine the heat conducted to adjacent tissue 70.

5           With regards to the detection of boiling of the fluid, such may be physically detected by the user (e.g. visually by the naked eye) of the electrosurgical device 5 in the form of either bubbles or steam evolving from the fluid coupling at the electrode/tissue interface. Alternatively, such a phase change (i.e. from liquid to vapor or vice-versa) may be measured by a sensor which preferably senses either an  
10 absolute change (e.g. existence or non-existence of boiling with binary response such as yes or no) or a change in a physical quantity or intensity and converts the change into a useful input signal for an information-gathering system. For example, the phase change associated with the onset of boiling may be detected by a pressure sensor, such as a pressure transducer, located on the electrosurgical device 5.  
15 Alternatively, the phase change associated with the onset of boiling may be detected by a temperature sensor, such as a thermistor or thermocouple, located on the electrosurgical device 5, such as adjacent to the electrode. Also alternatively, the phase change associated with the onset of boiling may be detected by a change in the electric properties of the fluid itself. For example, a change in the electrical  
20 resistance of the fluid may be detected by an ohm meter; a change in the amperage may be measured by an amp meter; as change in the voltage may be detected by a volt meter; and a change in the power may be determined by a power meter.

Yet another control strategy which may be employed for the electrosurgical device 5 is to eliminate the heat conduction term of equation (1) (i.e.  $\Delta T/R$ ). Since  
25 the amount of heat conducted away to adjacent tissue can be difficult to precisely predict, as it may vary, for example, by tissue type, it may be preferable, from a control point of view, to assume the worst case situation of zero heat conduction, and provide enough saline so that if necessary, all the RF power could be used to heat up and boil the saline, thus providing that the peak tissue temperature will not  
30 go over 100 °C a significant amount. This situation is shown in the schematic graph of FIG. 3.

Stated another way, if the heat conducted to adjacent tissue 70 is overestimated, the power **P** required to intersect the 100% boiling line 80 will, in turn, be overestimated and the 100% boiling line 80 will be transgressed into the T  
35 >> 100 °C region of FIG. 2, which is undesirable as established above. Thus, assuming the worse case situation of zero heat conduction provides a “safety factor” to avoid transgressing the 100% boiling line 80. Assuming heat conduction to adjacent tissue 70 to be zero also provides the advantage of eliminating the only



term from equation (1) which is tissue dependent, i.e., depends on tissue type. Thus, provided  $\rho$ ,  $c_p$ ,  $\Delta T$ , and  $h_v$  are known as indicated above, the equation of the line for any line of constant % boiling is known. Thus, for example, the 98% boiling line, 80% boiling line, etc. can be determined in response to a corresponding input from the selection switch 12. In order to promote flexibility, it should be understood that the input from the selection switch preferably may comprise any percentage of boiling. Preferably the percentage of boiling may be selected in single percent increments (i.e. 100%, 99%, 98%, etc.).

Upon determination of the line of the onset of boiling 76, the 100% boiling line 80 or any line of constant % boiling there between, it is generally desirable to control the flow rate  $Q$  so that it is always on a particular line of constant % boiling for consistent tissue effect. In such a situation, the flow rate controller 11 will adjust the flow rate  $Q$  of the fluid to reflect changes in power  $P$  provided by the generator 6, as discussed in greater detail below. For such a use the flow rate controller may be set in a line of constant boiling mode, upon which the % boiling is then correspondingly selected.

As indicated above, it is desirable to control the saline flow rate  $Q$  so that it is always on a line of constant % boiling for consistent tissue effect. However, the preferred line of constant % boiling may vary based on the type of electrosurgical device 5. For example, if the device is a monopolar stasis device and shunting through saline is not an issue, then it can be preferable to operate close to or directly on, but not over the line of the onset of boiling, such as 76a in FIG. 3. This preferably keeps tissue as hot as possible without causing desiccation. Alternatively, if the device has coaptive bipolar opposing jaws and shunting of electrical energy from one jaw to the other jaw through excess saline is an issue, then it can be preferable to operate along a line of constant boiling, such as line 78a in FIG. 3, the 50% line. This simple proportional control will have the flow rate determined by equation (4), where  $K$  is the proportionality constant:

$$Q_1 = K \times P \quad (4)$$

In essence, when power  $P$  goes up, the flow rate  $Q$  will be proportionately increased. Conversely, when power  $P$  goes down, the flow rate  $Q$  will be proportionately decreased.

The proportionality constant  $K$  is primarily dependent on the fraction of saline that boils, as shown in equation (5), which is equation (3) solved for  $K$  after eliminating  $P$  using equation (4), and neglecting the conduction term ( $\Delta T/R$ ):

$$K = \frac{1}{\{\rho c_p \Delta T + \rho h_v Q_b / Q_i\}} \quad (5)$$

Thus, the present invention provides a method of controlling boiling of fluid, such as a conductive fluid, at the tissue/electrode interface. In a preferred embodiment, this provides a method of treating tissue without use of tissue sensors, such as temperature or impedance sensors. Preferably, the invention can control boiling of conductive fluid at the tissue/electrode interface and thereby control tissue temperature without the use of feedback loops.

In describing the control strategy of the present invention described thus far, focus has been drawn to a steady state condition. However, the heat required to warm the tissue to the peak temperature (T) may be incorporated into equation (1) as follows:

$$P = \Delta T / R + \rho c_p Q_i \Delta T + \rho Q_b h_v + \rho c_p V \Delta T / \Delta t \quad (6)$$

where  $\rho c_p V \Delta T / \Delta t$  represents the heat required to warm the tissue to the peak temperature (T) and where :

- $\rho =$  Density of the saline fluid that gets hot but does not boil (approximately 1.0 gm/cm<sup>3</sup>);
- $c_p =$  Specific heat of the saline (approximately 4.1 watt-sec/gm-°C);
- $V =$  Volume of treated tissue
- $\Delta T =$  (T - T<sub>∞</sub>) the difference in temperature between the peak tissue temperature (T) and the normal temperature (T<sub>∞</sub>) of the body tissue (°C). Normal temperature of the body tissue is generally 37 °C; and
- $\Delta t =$  (t - t<sub>∞</sub>) the difference in time to achieve peak tissue temperature (T) and the normal temperature (T<sub>∞</sub>) of the body tissue (°C).

The inclusion of the heat required to warm the tissue to the peak temperature (T) in the control strategy is graphically represented at 68 in FIG. 2A. With respect to the control strategy, the effects of the heat required to warm the tissue to the peak temperature (T) should be taken into account before flow rate Q adjustment being undertaken to detect the location of the line of onset of boiling 76. In other words, the flow rate Q should not be decreased in response to a lack of boiling before at least a quasi-steady state has been achieved as the location of the line of onset of boiling 76 will continue to move during the transitory period. Otherwise, if the flow rate Q is decreased during the transitory period, it may be possible to decrease the flow Q to a point past the line of onset of boiling 76 and continue past the 100%

boiling line **80** which is undesirable. In other words, as temperature (T) is approached the heat **68** diminishes towards zero such that the lines of constant boiling shift to the left towards the Y-axis.

FIG. 4 shows an exemplary graph of flow rate **Q** versus % boiling for a situation where the RF power **P** is 75 watts. The percent boiling is represented on the X-axis, and the saline flow rate **Q** (cc/min) is represented on the Y-axis. According to this example, at 100 % boiling the most desirable predetermined saline flow rate **Q** is 2 cc/min. Also according to this example, flow rate **Q** versus % boiling at the remaining points of the graft illustrates a non-linear relationship as follows:

Table 1 – % Boiling and Flow Rate **Q** (cc/min) at RF Power **P** of 75 watts

	0%	17.4
	10%	9.8
15	20%	6.8
	30%	5.2
	40%	4.3
	50%	3.6
	60%	3.1
20	70%	2.7
	80%	2.4
	90%	2.2
	100%	2.0

Typical RF generators used in the field have a power selector switch to 300 watts of power, and on occasion some have been found to be selectable up to 400 watts of power. In conformance with the above methodology, at 0% boiling with a corresponding power of 300 watts, the calculated flow rate **Q** is 69.7 cc/min and with a corresponding power of 400 watts the calculated flow rate **Q** is 92.9 cc/min. Thus, when used with typical RF generators in the field, a fluid flow rate **Q** of about 100 cc/min or less with the present invention is expected to suffice for the vast majority of applications.

As discussed herein, RF energy delivery to tissue can be unpredictable and vary with time, even though the generator has been “set” to a fixed wattage. The schematic graph of FIG. 5 shows the general trends of the output curve of a typical general-purpose generator, with the output power changing as load (tissue plus cables) impedance **Z** changes. Load impedance **Z** (in ohms) is represented on the X-axis, and generator output power **P** (in watts) is represented on the Y-axis. In the

illustrated embodiment, the electrosurgical power (RF) is set to 75 watts in a bipolar mode. As shown in the figure, the power will remain constant as it was set as long as the impedance  $Z$  stays between two cut-offs, low and high, of impedance, that is, for example, between 50 ohms and 300 ohms in the illustrated embodiment. Below  
5 load impedance  $Z$  of 50 ohms, the power  $P$  will decrease, as shown by the low impedance ramp **82a**. Above load impedance  $Z$  of 300 ohms, the power  $P$  will decrease, as shown by the high impedance ramp **82b**. Of particular interest to saline-enhanced electrosurgery is the low impedance cut-off (low impedance ramp **82a**), where power starts to ramp down as impedance  $Z$  drops further. This change  
10 in output is invisible to the user of the generator and not evident when the generator is in use, such as in an operating room.

FIG. 6 shows the general trend of how tissue impedance generally changes with time for saline-enhanced electrosurgery. As tissue heats up, the temperature coefficient of the tissue and saline in the cells is such that the tissue impedance  
15 decreases until a steady-state temperature is reached upon which time the impedance remains constant. Thus, as tissue heats up, the load impedance  $Z$  decreases, potentially approaching the impedance  $Z$  cut-off of 50 ohms. If tissue is sufficiently heated, such that the low impedance cut-off is passed, the power  $P$  decreases along the lines of the low impedance ramp **82a** of FIG. 5.

Combining the effects shown in FIG. 5 and FIG. 6, it becomes clear that  
20 when using a general-purpose generator set to a "fixed" power, the actual power delivered can change dramatically over time as tissue heats up and impedance drops. Looking at FIG. 5, if the impedance  $Z$  drops from 100 to 75 ohms over time, the power output would not change because the curve is "flat" in that region of  
25 impedances. If, however, the impedance  $Z$  drops from 75 to 30 ohms one would transgress the low impedance cut-off and "turn the corner" onto the low impedance ramp **82a** portion of the curve and the power output would decrease dramatically.

According to one exemplary embodiment of the invention, the control device, such as flow rate controller **11**, receives a signal indicating the drop in actual  
30 power delivered to the tissue and adjusts the flow rate  $Q$  of saline to maintain the tissue/electrode interface at a desired temperature. In a preferred embodiment, the drop in actual power  $P$  delivered is sensed by the power measurement device **8** (shown in FIG. 1), and the flow rate  $Q$  of saline is decreased by the flow rate controller **11** (also shown in FIG. 1). Preferably, this reduction in saline flow rate  $Q$   
35 allows the tissue temperature to stay as hot as possible without desiccation. If the control device was not in operation and the flow rate  $Q$  allowed to remain higher, the tissue would be over-cooled at the lower power input. This would result in decreasing the temperature of the tissue at the treatment site.

The flow rate controller **11** of FIG. **1** can be a simple “hard-wired” analog or digital device that requires no programming by the user or the manufacturer. The flow rate controller **11** can alternatively include a processor, with or without a storage medium, in which the determination procedure is performed by software,  
5 hardware, or a combination thereof. In another embodiment, the flow rate controller **11** can include semi-programmable hardware configured, for example, using a hardware descriptive language, such as Verilog. In another embodiment, the flow rate controller **11** of FIG. **1** is a computer, microprocessor-driven controller with software embedded. In yet another embodiment, the flow rate controller **11** can  
10 include additional features, such as a delay mechanism, such as a timer, to automatically keep the saline flow on for several seconds after the RF is turned off to provide a post-coagulation cooling of the tissue or “quench,” which can increase the strength of the tissue seal. Also, in another embodiment, the flow rate controller **11** can include a delay mechanism, such as a timer, to automatically turn on the  
15 saline flow several seconds before the RF is turned on to inhibit the possibility of undesirable effects as sticking, desiccation, smoke production and char formation. Also in another embodiment, the flow rate controller **11** can include a low level flow standby mechanism, such as a valve, which continues the saline flow at a standby flow level (which prevents the flow rate from going to zero when the RF power is  
20 turned off) below the surgical flow level ordinarily encountered during use of the electro-surgical device **5**.

An exemplary electro-surgical device of the present invention which may be used in conjunction with the system of the present invention is shown at reference character **5a** in FIG. **9**, and more particularly in FIGS. **9-16**. While various  
25 electro-surgical devices of the present invention are described with reference to use with the remainder of the system of the invention, it should be understood that the description of the combination is for purposes of illustrating the remainder of the system of the invention only. Consequently, it should be understood that the electro-surgical devices of the present invention can be used alone, or in conjunction  
30 with the remainder of the system of the invention, or that a wide variety of electro-surgical devices can be used in connection with the remainder of the system of the invention.

As shown in FIGS. **7** and **8**, electro-surgical device **5a** is preferably used in conjunction with a viewing scope, shown as an endoscope as illustrated at reference  
35 character **17**, during a minimally invasive procedure such flexible endoscopic gastro-intestinal surgery. The endoscope **17** preferably comprises an elongated flexible shaft portion **17a**, though device **5a** may be used with rigid shaft viewing scopes, for example, during laparoscopic surgery.

Endoscope **17** also comprises a proximal portion **17b** separated from a distal portion **17c** by shaft portion **17a**. Proximal portion **17b** of endoscope **17** preferably comprises a control head portion **17d**. Control head portion **17d** preferably comprises a tissue treatment site viewer **17e** and one or more directional control knobs **17f** and **17g** to control the movement of the flexible distal portion **17c** of flexible shaft **17a**. Control knob **17f** preferably comprises a right/left angulation control knob while control knob **17g** preferably comprises an up/down angulation control knob.

As shown in FIG. **8**, flexible shaft **17a** houses at least one device channel **17h** through which surgical device **5a** may be passed. Also as shown, flexible shaft **17a** also preferably contains at least one viewing channel **17i** to enable viewing through the distal portion **17c**. Flexible shaft **17a** also preferably contains at least one fluid flow channel **17j** for providing liquid (e.g. water) or gas (e.g. air) to a tissue treatment site. Also preferably, electrosurgical device **5a** is configured to extend from the distal end portion **17c**, and more preferably, the distal end surface **17k** of endoscope **17**, as shown in FIG. **8**.

As shown in FIGS. **11** and **12**, electrosurgical device **5a** is preferably assembled (e.g. mechanically connected via press-fit, mechanical connector, welded, adhesively bonded) adjacent the distal end **18** of a long, hollow, tube **19** to preferably form a medical device assembly. Tube **19** is preferably self-supporting and flexible, and more preferably comprises a catheter which may be use when flexed to apply tamponade (e.g. compressive force) through the electrosurgical device **5a** to a bleeding source in the gastrointestinal tract. Electrosurgical device **5a** in combination with a catheter may be referred to as a catheter assembly.

As best shown in FIGS. **10** and **12**, electrosurgical device **5a** is also preferably electrically connected to the conductors **38a**, **38b** of insulated electrical wires **21a**, **21b**, respectively, which have been passed through lumen **23** of tube **19** as branches of cable **9** which is connected to generator **6**. However, in alternative embodiments, the tube **19** may incorporate the conductors **38a**, **38b** of wires **21a**, **21b** in the tube wall (in essence creating a multi-lumen tube comprising three lumens where two of the lumens are occupied exclusively by the conductors **38a**, **38b** of wires **21a**, **21b**) to reduce the complexity of items being passed down lumen **23**. Thereafter, electrosurgical device **5a** along with the flexible tube **19** and wires **21a**, **21b** contained therein may enter channel entrance opening **17l** of device channel **17h** and are thereafter passed through and along at least a portion of the length of device channel **17h** until exiting from channel exit opening **17m**.

As shown throughout FIGS. **9-16**, and particularly FIGS. **12** and **15**, electrosurgical device **5a** comprises a probe body **26**. Probe body **26** is preferably

sized to pass from entrance **17i** to the exit **17m** of device channel **17h** of scope **17**. Probe body **26** may comprise a solid, electrically non-conductive, insulative material impervious to the flow of fluid **24** therethrough including, but not limited to, ceramic or polymer materials. Examples of non-conductive polymer materials  
5 include, but are not limited to, polyamide (a/k/a nylon), polyphthalamide (PPA), polyamideimide (PAI), polyetherimide (PEI), polyetheretherketone (PEEK), polyphenylenesulfide (PPS), polysulfone (PSO), polyethersulfone (PES), syndiotactic polystyrene (SPS), polyimide (PI) or any other non-conductive polymer, thermoplastic or thermoset. Probe body **26** may also comprise a liquid  
10 crystal polymer and, more particularly, an aromatic liquid crystal polyester which is reinforced with glass fiber, such as Vectra® A130 from Ticona, 90 Morris Avenue, Summit, New Jersey 07901-3914. Where probe body **26** comprises a ceramic, it may comprise a machinable ceramic material such as sold under the tradename MACOR. In other embodiments, the non-conductive material of the probe body **26**  
15 may be coated with a non-conductive, lubricating or non-stick coating, such as polytetrafluoroethylene (PTFE).

As shown throughout FIGS. 9-16, electrosurgical device **5a** is greatly enlarged since, for example, in one exemplary embodiment the cross-sectional dimension of device **5a**, specifically its diameter, is about 7 French (about 2.4mm or  
20 0.095 inches). In another embodiment, the cross-sectional dimension of electrosurgical device **5a** may be about 10 French (about 3.2 mm or 0.126 inches). In still other embodiments, electrosurgical device **5a** may be configured with any cross-sectional dimension suitable to pass through the working channel of a viewing scope or of a trocar (also known as a cannula) where such a device is required.

25 As shown in FIGS. 9-12, for interacting with tissue, electrosurgical device **5a** and, in particular, probe body **26**, preferably comprise a generally cylindrical shape **32** with the distal end portion of the electrosurgical device **5a** and probe body **26** preferably comprising a generally domed, hemispherical shape **67**, such as that of a semi-circle, which provides a smooth, blunt contour outer surface.

30 As best shown in FIG. 12, electrosurgical device **5a** preferably comprises a fluid flow manifold **40** located within probe body **26**. Manifold **40** preferably comprises a discrete, rectilinear, longitudinally directed, central fluid flow passage **41**, preferably located on-center about longitudinal axis **31** of electrosurgical device **5a**. For device **5a**, central flow passage **41** preferably extends between proximal end  
35 **35** and distal end **27** of electrosurgical device **5a** through probe body **26** and has a central flow passage fluid entrance opening **42** located adjacent the proximal end **35** of probe body **26**. As shown in FIG. 12, central flow passage **41** preferably extends into and is fluidly coupled with lumen **23** of flexible tube **19**.

As best shown in FIGS. 12, 15 and 16, manifold 40 preferably comprises at least one discrete, rectilinear, lateral fluid flow passage 43 which is fluidly coupled to central fluid flow passage 41. As shown, preferably manifold 40 comprises a plurality of discrete, rectilinear, lateral fluid flow passages 43a, 43b which are defined and spaced both longitudinally along and circumferentially around the probe body 26 and central fluid flow passage 41. More preferably the lateral fluid flow passages 43a, 43b are defined and spaced from proximal end 35 of electro-surgical device 5a through probe body 26 to the distal end 27 of electro-surgical device 5a through probe body 26.

Also as best shown in FIGS. 15 and 16, for device 5a lateral fluid flow passages 43a, 43b preferably each have a cross-sectional dimension, more specifically diameter, and corresponding cross-sectional area, less than the portion of central fluid flow passage 41 from which fluid 24 is provided. Also, as best shown in FIG. 12, 15 and 16, the lateral fluid flow passages 43a, 43b which preferably extend through the cylindrical portion 32 of probe body 26 are preferably formed substantially at a right angle (e.g. within about 10 degrees of a right angle) to the central fluid flow passage 41, both longitudinally and circumferentially. Also as shown in FIGS. 12, 15 and 16, the lateral fluid flow passages 43a, 43b are preferably formed substantially at a right angle to the outer tissue interacting/treating surfaces 28, 50 of the electro-surgical device 5a.

Preferably, lateral fluid flow passages 43a, 43b extend from central fluid flow passage 41 to lateral flow passage fluid exit openings 44a, 44b located on surfaces of electro-surgical device 5a configured for interacting with and treating tissue. As shown in FIGS. 12, 15 and 16, lateral flow passage fluid exit openings 44a, 44b are located on exposed outer surface 28 of probe body 26, or an exposed outer surface 50 of electrode 29a-c, 30a-c, which are discussed in greater detail later in this specification. More preferably, lateral fluid flow passages 43a, 43b preferably are configured to extend from central fluid flow passage 41 to lateral flow passage fluid exit openings 44a, 44b located on the outer surface 28 of probe body 26 and outer surface 50 of electrodes 29a-c, 30a-c, respectively, such that lateral flow passages 43a, 43b and associated fluid exit openings 44a, 44b are defined and spaced both longitudinally along and circumferentially around the outer surfaces 28 and 50 of electro-surgical device 5a, preferably between proximal end 35 of electro-surgical device 5a and the distal end 27 of electro-surgical device 5a and probe body 26.

As best shown in FIGS 12, 15 and 16, central flow passage 41 may be lined by a liner 45, preferably comprising a non-corrosive, impervious (to fluid 24), metal tube (e.g. stainless steel tubing) located within a through bore 46 of probe body 26



which extends from proximal end **35** to distal end **27** of electrosurgical device **5a** and probe body **26**. Also as best shown in FIGS. **12**, **15** and **16**, preferably the outer wall surface of liner **45** contacts the inner surface of bore **46** of probe body **26** and discrete lateral fluid flow passages **43a**, **43b** extend through the wall thereof.

5 Alternatively, liner **45** may comprise a cylindrical coil spring with the lateral openings provided between the coils of the spring.

As best shown in FIG. **12**, distal wall section **25** of liner **45** adjacent distal end **27** of the electrosurgical device **5a** and probe body **26** partially defines the distal end of the wide proximal portion **41a** of the central flow passage **41** (with the  
10 proximal end of the distal narrow portion **41b** of the central flow passage **41** defining the remainder of the distal end of the wide portion **41a** of the central flow passage **41** in this embodiment). Distal wall section **25** of liner **45** also narrows the central flow passage **41** from wide portion **41a** to narrow portion **41b** and defines a narrow central fluid passage exit opening **62**. As shown, in this manner, preferably,  
15 the distal portion of the central flow passage **41** comprises a counterbore configuration. In other words, two adjacent circular openings about the same axis, but of different diameter. More particularly, wide portion **41a** and narrow portion **41b** of central flow passage **41** preferably comprise the configuration of a counterbore adjacent the distal end **27** of electrosurgical device **5a**.

20 During use of electrosurgical device **5a**, the distal wall section **25** inhibits fluid flow from wide portion **41a** through the narrow portion **41b** of the central flow passage **41**. In other words, distal wall **25** inhibits fluid **24** from exiting from the central fluid passage exit opening **62** as compared to a situation where distal wall **25** would not be used and the central flow passage **41** only would consist of wide  
25 portion **41a**. In the above manner, at least a portion of the distal end of the central flow passage **41** is defined by an occlusion (i.e. wall section **25**) formed by a portion of the electrosurgical device **5a**.

More preferably, wall section **25** substantially occludes and inhibits fluid **24** from exiting from the central flow passage exit opening **62**. Throughout this  
30 specification, occlusion of central flow passage **41** and the corresponding inhibiting of flow from exiting from the central fluid passage exit opening **62** of the central flow passage **41** can be considered substantial when the occlusion and corresponding inhibiting of flow results in increased flow from the lateral flow passages **43a**, **43b**. In other words, the occlusion functions as a fluid flow diverter and redirects fluid  
35 coming in contact therewith from flowing parallel with the longitudinal axis **31** of central flow passage **41** to flowing radially from the longitudinal axis **31** through lateral flow passages **43a**, **43b**.

As best shown in FIGS. 12, 15 and 16, preferably the probe body 26 has an outer surface 52 on which at least a portion of one energy providing member is located, overlies and is connected. As shown in FIGS. 9 and 10, the energy providing member preferably comprises a pair of electrical conductors 29, 30 which are  
5 respectively electrically connected to insulated wires 21a, 21b which are ultimately connected to generator 6. Conductors 29, 30 preferably comprise an electrically conductive metal, which is preferably non-corrosive, such as stainless steel or titanium.

The conductors 29, 30 are preferably configured to provide energy to tissue  
10 for hemostatic therapy and/or for tissue treatment of the wall of an anatomical tube. Each conductor 29, 30 may be branched into, for example, additional sub-conductors, such as comprising three elongated longitudinally directed strip electrodes 29a, 29b, 29c and 30a, 30b, 30c which will provide energy to treat tissue. As shown, the electrodes may be aligned generally parallel with the longitudinal axis  
15 31 on the peripheral surface of the probe body 26 (comprising exposed probe body surfaces 28 and covered probe body surfaces 52) and are preferably angularly uniformly distributed, in this embodiment at angular intervals of 60 degrees. The electrodes 29a-c, 30a-c of conductors 29 and 30 are respectively successively spaced from each other by gaps, G. In one embodiment, the gaps G are generally at  
20 least about twice the widths W of the electrodes at the cylindrical portion 32 of the probe body 26. For a probe body 26 of a 2.4 mm diameter, the gaps G are about 0.8 mm and the widths W are about 0.4 mm. Generally, the wider the gap G between the electrodes the deeper the effect on tissue being treated.

Preferably, the electrodes 29a-c, 30a-c are provided alternating electrical  
25 current, so that the electrodes alternate polarity between positive and negative charges, and adjacent electrodes comprises opposite polarities at any given time to create an electrical field with current flow from the positive to negative charge. In other words, for example, preferably while electrodes 29a-c comprise a first polarity (e.g. positive), electrodes 30a-c comprise a second opposite polarity (e.g. negative).  
30 In the above manner, the plurality of uniformly distributed opposite electrode pairs formed around the longitudinal axis 31 create one or more bipolar electrical circuits, with the number of electrode poles generally equal to the number of circuits. For example, with the six electrode poles described above, an electrical array which extends circumferentially around longitudinal axis 31 and device 5a comprising six  
35 bipolar circuits is created between adjacent successive poles as shown by electrical field lines 57a-f in FIG. 13.

Conductors 29, 30, including electrodes 29a-c, 30a-c may comprise preformed metal which is then placed on probe body 26, or formed-in-place metal

which comprises a metallic compound which is formed-in-place on the probe body 26, typically via painting or spraying. In one particular embodiment, conductors 29, 30 and electrodes 29a-c, 30a-c may be formed by first applying metal completely to the outer surfaces 28 and 52 of probe body 26 (such as by dip coating the outer surface in a liquid metal bath) then removing metal in excess of the conductors 29, 30 and electrodes 29a-c, 30a-c from the surface 28 to define the conductors 29, 30 and electrodes 29a-c, 30a-c, such as by the use of a laser.

Also as shown in FIGS. 9 and 10, where elongated, longitudinally directed electrodes are utilized (e.g. from the proximal end 35 to the distal end 27 of the electrosurgical device 5a and probe body 26), such as with electrosurgical device 5a, preferably at least three sets of opposite electrode poles are provided. In this manner, at least bipolar, and frequently greater, polar tissue contact and electrocoagulation can be achieved substantially independent of the orientation of the probe body 26 relative to the tissue treatment site. This is advantageous when the device 5a is used through endoscope 17 so that front end use (e.g. domed portion 67), sideways use (e.g. cylindrical portion 32) or oblique use (e.g. combination of domed portion 67 and cylindrical portion 32) of the electrosurgical device 5a results in at least a bipolar contact with the tissue treatment site.

As best shown in FIGS. 10 and 14, electrodes 29a-c of conductor 29 are preferably electrically coupled to each other at the proximal end 35 of the probe body 26. Preferably, electrodes 29a-c of conductor 29 are electrically coupled via a conductor 29 which comprises an electrically conductive radial band, preferably located on a radially recessed shoulder 34 of probe body 26 located at the proximal end 35 of probe body 26. The electrical coupling between electrodes 29a-c and conductor 29 is preferably made via radially displaced localized conductive tabs 36a-c. In turn, conductor 38b of insulated wire 21b is preferably connected to band preferably in a notch 37 formed in the band and in shoulder 34, where notch 37 is sized to receive conductor 38b of wire 21b. Conductor 38b of insulated wire 21b is preferably connected to a surface 39 of notch 37 via an electrical connector comprising solder (e.g. silver) from soldering.

As best shown in FIGS. 9 and 12, electrodes 30a-c of conductor 30 are preferably electrically coupled to each other at the distal end 27 of the electrosurgical device 5a and probe body 26. Preferably, electrodes 30a-c of conductor 30 are electrically coupled via a conductor 30 comprising an electrically conductive hub preferably located at the distal end 27 of the electrosurgical device 5a and probe body 26. A wall section 47 of the conductor 30 overlying wall section 25 of liner 45 may also function as an occlusion which either partially defines the distal portion of the central flow passage 41 (i.e. where central flow passage 41 comprises

a narrow portion **41b** and a central fluid passage exit opening **62**) or completely defines the distal end of the central flow passage **41** (i.e. where the central flow passage does not continue through the wall section **47** of conductor **30**), particularly when liner **45** is not occluded at its distal end (i.e. does not include wall section **25**).

5           Conductor **30** is preferably electrically coupled to hollow conductive metal liner **45** to which, in turn, conductor **38a** of insulated wire **21a** is preferably connected to a surface of hollow metal liner **45** at the proximal end **35** of probe body **26** via an electrical connector comprising solder (e.g. silver) from soldering. Alternatively where, for example, liner **45** is not utilized, conductor **38a** of insulated  
10 wire **21a** may be connected to an inner surface **49** of conductor **30**.

As shown in FIGS. **9** and **16**, preferably the plurality of lateral flow passages **43a** which extend through probe body **26** to fluid exit openings **44a** are defined and spaced along the outer surface **28** of probe body **26** between at least one pair of adjacent electrodes. As shown, preferably the plurality of lateral flow passage fluid  
15 exit openings **44a** are configured to form both longitudinal and circumferential straight rows, and are preferably uniformly spaced relative to one another. Also, preferably lateral flow passages **43a** are configured to distribute fluid flow exiting from fluid exit openings **44a** substantially uniformly. Lateral flow passages **43a** of this exemplary embodiment preferably have a cross-sectional dimension (e.g.  
20 diameter) in the range between and including about 0.1 mm to 2 mm and more preferably have a diameter in the range between and including about 0.15 mm to 0.2 mm.

Also as shown in FIGS. **9** and **15**, preferably the plurality of lateral flow passages **43b** which extend through probe body **26** and at least one electrode **29a-c**,  
25 **30 a-c** to fluid exit openings **44b** are defined and spaced along the outer surface **50** of electrodes **29a-c**, **30a-c**. As shown, preferably the plurality of lateral flow passage fluid exit openings **44b** are configured to form both longitudinal and circumferential straight rows, and are preferably uniformly spaced relative to one another. Also, preferably lateral flow passages **43b** are configured to distribute fluid  
30 flow exiting from fluid exit openings **44b** substantially uniformly. Lateral flow passages **44b** of this exemplary embodiment preferably have a cross-sectional dimension (e.g. diameter) in the range between and including about 0.1 mm to 2 mm and more preferably have a diameter in the range between and including about 0.15 mm to 0.2 mm.

35           As best shown in FIG. **10**, electrical device **5a** preferably further comprises a member **51** which comprises a gasket portion **51a** configured to electrically insulate conductors **38a**, **38b** from one another and inhibit a short circuit (i.e. a low resistance, alternate path through which current will flow, often resulting in damage,

rather than through the load circuit) from forming between conductors of different electrical potential (e.g. conductors **29/38b** with conductors **30/38a**) in the presence of electrically conductive fluid, which would cause electrical current to flow between conductors (e.g. **29/38b** and **30/38a**) prior to the current reaching electrodes **29a-c** and **30a-c**, thus bypassing or detouring away from the electrodes. Member **51** preferably comprises an insulative flexible polymer material, such as an elastomer and, in this embodiment, preferably comprises the geometry of a thin, flat circular member, such as that of a washer. As shown in FIG. **10**, gasket portion **51a** surrounds aperture **51b** through which wire **21b** extends. Thereafter, gasket portion **51a** preferably forms a gasket with the insulator of wire **21b** to inhibit fluid **24** from lumen **23** of tube **19** from contacting conductors **38b** and **29**.

Member **51** also preferably includes a second gasket portion **51c** which surrounds aperture **51d** through which liner **45** extends and thereafter forms a gasket with the outer surface of liner **45** to also inhibit fluid **24** from lumen **23** of tube **19** from contacting conductor **38b** or **29**.

In other embodiments, electrical device **5a** may further comprise a sensor, such as probe body **26** itself, for sensing, for example, temperature, pressure or saline impedance sensor for sensing the phase change associated with the onset of boiling, or which may be located in or on probe body **26**, adjacent an electrode and/or the tissue.

As best shown in FIGS. **12**, **15** and **16**, probe body **26** preferably comprises a circular shape with a uniform diameter along the longitudinal length of the cylindrical portion **32**. As best shown in FIGS. **15** and **16**, the outer surface **50** of at least a portion of at least one of the electrodes **29a-c**, **30a-c** is stepped up or otherwise protruding relative to an adjacent exposed outer surface **28** of the probe body **26** by the thickness of the electrodes, preferably in a thickness range between and including about 0.01 mm to 2.0 mm and, more preferably, in the range between and including about 0.1 mm to 0.5 mm. As shown in FIGS. **15** and **16**, the outer surface **50** of all of the electrodes **29a-c**, **30a-c** is stepped up relative to an adjacent exposed outer surface **28** of the probe body **26** by the thickness of the electrodes.

Another exemplary electrosurgical device of the present invention which may be used in conjunction with the system of the present invention is shown at reference character **5b** in FIG **17**, and more particularly in FIGS. **17-19**. As best shown in FIG. **19**, at least a portion of at least one of the electrodes **29a-c**, **30a-c** is located in a recess such that the outer surface **50** of the electrodes is flush relative to an adjacent exposed outer surface **28** of the probe body **26**. As shown in FIG. **19**, all the electrodes **29a-c**, **30a-c** are located in recesses **53** with the depth of the recesses **53** equal to the thickness of the electrodes such that the outer surface **50** of the

electrodes **29a-c**, **30a-c** is flush relative to an adjacent exposed outer surface **28** of the probe body **26**. In this manner, device **5b** may tend to move along the surface of the tissue more easily than **5a** as the surface roughness associated with protruding electrodes is eliminated.

5           Another exemplary electrosurgical device of the present invention which may be used in conjunction with the system of the present invention is shown at reference character **5c** in FIG **20**, and more particularly in FIGS. **20-22**. As best shown in FIG, **22**, recess **53** provides, at least in part, at least one elongated fluid flow channel **54** for fluid **24**. Also as shown in FIG. **22**, preferably at least a portion  
10 of at least one of the electrodes **29a-c**, **30a-c** is located in the recess **53**, and preferably such that the outer surface **50** of the electrodes is stepped down or otherwise recessed relative to an adjacent exposed outer surface **28** of the probe body **26**. As shown in FIG. **22**, all the electrodes **29a-c**, **30a-c** are located in recesses **53**, with the depth of the recesses **53** greater than the thickness of the  
15 electrodes such that the outer surface **50** of the electrodes **29a-c**, **30a-c** is stepped down relative to an adjacent exposed outer surface **28** of the probe body **26**. Also as shown in FIG. **22**, the fluid flow channel **54** is preferably provided in the portion of the recess **53** overlying the outer surface **50** of the electrodes **29a-c**, **30a-c**.

          Preferably the configuration of the fluid flow channel **54** as provided by  
20 geometry (e.g. width, depth), the material and/or surface treatment of the probe body **26**, and/or the material and/or surface treatment of the electrodes **29a-c**, **30a-c**, and may be arranged such that surface tension will act to retain fluid collected in the channel **54** where the force of gravity is acting to remove the fluid from the channel  
25 **54**. However, while it is desirable that a certain predetermined amount of surface tension act to retain fluid collected in the channel **54** in the presence of gravity, the surface tension must be balanced against the inhibition of fluid flow from lateral flow passages **43b**. While partial inhibition from lateral flow passages **43b** is acceptable, fluid flow channel **54** should not be configured and arranged such that surface tension will act to completely inhibit or prevent fluid from flowing out of  
30 lateral flow passages **43b**.

          Among other things, fluid flow channel **54** provides a distribution conduit for distributing fluid contained therein, which has passed through lateral fluid flow passages **43b** from central flow passage **41**, more uniformly on the outer surface **50** of the electrodes **29a-c**, **30a-c** as compared to the situation where fluid flow channel  
35 **54** is not used. In other words, the use of fluid flow channel **54** will generally increase the surface area **50** of the electrodes **29a-c**, **30a-c** covered with fluid from lateral fluid flow passages **43b** as compared to the situation where fluid flow channel **54** is not used.

Among other things, fluid flow channel **54** also provides a distribution conduit for distributing fluid contained therein, which has passed through lateral fluid flow passages **43b** from central flow passage **41**, more uniformly on the adjacent exposed outer surfaces **28** of the probe body **26** as compared to the situation  
5 where fluid flow channel **54** is not used. For example, the use of fluid flow channel **54** will generally increase the surface area **28** of the probe body **26** covered with fluid from lateral fluid flow passages **43b** as a result of fluid overflowing out of the channel **54** along the longitudinal length of the channel **54** and flowing over the surface **28** of the probe body **26** as compared to the situation where fluid flow  
10 channel **54** is not used.

In use, when tissue **20** overlies and occludes the opening **55** of fluid flow channel **54** for a portion of its longitudinal length, thus inhibiting fluid flow exiting therefrom, fluid from channel **54** may still be expelled from the electrosurgical device **5c** after flowing longitudinally in the channel **54** to a remote location,  
15 typically at distal end **27** of electrosurgical device **5c** and probe body **26**, where the channel **54** is unoccluded and uninhibited to fluid flow exiting therefrom.

However, in certain instances, it may be possible that fluid flow channel **54** may be occluded by tissue **20** completely along its longitudinal length, thus completely inhibiting fluid flow from exiting through opening **55**. In order to  
20 overcome this problem, at least a portion of probe body **26** may comprise a material pervious to the passage of fluid **24**, therethrough, such as a porous material. As shown in FIG. **23**, in another embodiment of the electrosurgical device of the present invention, as shown at reference character **5d** in FIG. **23**, the wall **56** of channel **54**, as well as exposed outer surface **28** of probe body **26** are porous and connected by a  
25 plurality of tortuous paths **59** in the porous material. Consequently, rather than flowing out of channel **54** from a direct opening **55**, which may be occluded by tissue **20**, the fluid may exit indirectly from the flow channel **54** by first flowing through tortuous paths **59** of probe body **26** from side walls **56** of the channel and then exit the probe body **26** from surface **28**, which may be in unoccluded by tissue  
30 **20**. Alternatively, if adjacent surface **28** of the probe body **26** is also occluded by tissue **20**, the fluid may continue to flow through tortuous paths **59** of probe body **26** and exit the probe body **26** from a surface **48** of a remote flow channel **54** or surface **28**, **50**, which may be in unoccluded by tissue **20**.

As also shown in FIG. **23**, in addition to the probe body **26** comprising a  
35 porous material, at least one of the electrodes **29a-c**, **30a-c** may also comprise a porous material. Consequently, fluid flowing through the tortuous paths **59** of the probe body **26** may exit from surface **52** of the probe body **26** covered by an electrode **29a-c**, **30a-c**, flow through the tortuous paths **60** of the electrode **29a-c**,

**30a-c** and then exit from outer surface **50** of the electrode **29a-c, 30a-c** to provide similar advantages as the porous probe body **26**.

Where the probe body **26** and/or electrodes **29a-c, 30a-c** comprise a porous material, the discrete, rectilinear lateral fluid flow passages **43a, 43b** may be either  
5 supplemented with or replaced by the plurality of tortuous, interconnected passages **59** and/or **60** formed in the porous material with a porous surface **28** and/or **50** to more evenly distribute fluid flow and allow infusion of the conductive solution to the tissue treatment site. Also alternatively, the lateral fluid flow passages **43a, 43b**  
10 may extend towards surfaces **28** and/or **50**, but terminate prior to surfaces **28** and/or **50** and not extend thereto, with passages **59** and/or **60** in fluid communication with lateral flow passages **43a, 43b** thereafter providing fluid **24** to surfaces **28** and/or **50**.

Where the probe body **26** comprises a porous non-electrically conductive material, the conductors **38a, 38b** and corresponding electrodes **29a-c, 30a-c**,  
15 respectively, may still be further insulated from one another to reduce power losses associated with any short circuit which may develop through the probe body **26** and, more particularly, through the conductive fluid flowing through the tortuous paths **59** of the probe body **26**. As shown also in FIG. **23**, in order to further insulate the respective poles from one another, a water resistant or water proof coating **58** may be located between surfaces of probe body **26** adjoining portions of the electrical  
20 circuit (e.g. conductors **38a, 38b** and electrodes **29a-c, 30a-c**), such as surface **33** of liner **45**, surface **63** of lateral flow passage **43**, the surface of the central flow passage **41**, the surface of bore **46** of probe body **26** and/or notch surface **39**.

With regards to porous electrodes **29a-c, 30a-c** porous sintered metal is available in many materials (such as, for example, 316L stainless steel, titanium, Ni-  
25 Chrome) and shapes from companies such as Porvair, located in Henderson, NC.

Porous metal components can be formed by a sintered metal powder process or by injection molding a two-part combination of metal and a material that can be burned off to form pores that connect (open cell) to each other. With sintering, for example, typically solid particles of material are placed in a mold under heat and  
30 pressure such that the outer surface of the particles soften and bond to one another with the pores comprising the interstices between the particles. Alternatively, when porosity is formed by burning off material, it is not the interstice between the particles which provides the porosity as with sintering, but rather a partial evisceration of the material generally provided by the removal of a component with  
35 a lower melt temperature than the burn off temperature.

With regards to a non-electrically conductive porous probe body **26**, porous polymers and ceramics can be used to replace non-porous polymers and ceramics, respectively. Suitable polymer materials include high temperature open cell silicone



foam and porous polycarbonates, among others. Different from sintering or  
evisceration of material, formation of porosity in open cell polymer foams is  
typically accomplished by the introduction of gas bubbles, either chemically or  
physically, into the polymer during its formation or melt phase which form a cellular  
5 structure. However, sintering or evisceration of material may also be used with  
polymer materials. While the porous polymers themselves are generally non-  
conductive, they may also be used to conduct the RF energy through the porous  
polymer thickness and surface to the tissue to be treated by virtue of conductive  
fluid contained within the plurality of interconnected tortuous passages.

10 Porous ceramics also generally fall into the category of being non-  
conductive, since they could distribute conductive fluid flow, withstand high  
temperatures and be machinable or moldable for manufacturing purposes.  
Preferably, the material used transmits both fluid flow and electrical energy; thus,  
materials with properties between high-electrical conductivity metals and low  
15 electrical conductivity polymers are also contemplated, such as porous carbon-filled  
polymers. In these embodiments, conductive fluid flow is distributed along the  
length of the electrodes, where porous material is used to fabricate the electrodes.  
All or a portion of the electrodes can be porous according to the invention.

Preferably the tortuous passages **59** and **60** in the porous materials have a  
20 pore size (cross-sectional dimension) in the range between and including about 2.5  
micrometers (0.0025 mm) to 500 micrometers (0.5 mm) and more preferably has  
pore size in the range between and including about 10 micrometers (0.01 mm) to  
120 micrometers (0.12 mm). Even more preferably, the porous material has a pore  
size in the range between and including about 20 micrometers (0.02 mm) to 80  
25 micrometers (0.08 mm).

In addition to providing a more uniform distribution of fluid exiting from  
channel **54**, the porous materials also provides other advantages. For example,  
lateral fluid flow passages **43a**, **43b** are difficult to mold or machine below a size of  
0.276 millimeters (0.007 inches). Conversely, the porous material may provide  
30 passages of a smaller dimension. Furthermore, in addition to providing smaller fluid  
passages, when the probe surface **28** and/or electrode surface **50** in contact with  
tissue **20** are porous and dissipate fluid, tissue **20** is less apt to stick to the surfaces  
**28** and/or **50** as compared to the situation where the surfaces **28** and/or **50** are not  
porous. In addition, by providing fluid to surfaces **28** through tortuous paths **59**,  
35 heated and/or electrified fluid can now be provided more uniformly to surface **28**,  
which results in a wider tissue treatment region as compared to when the surfaces **28**  
is not porous.

Preferably the porous material provides for the wicking (i.e. drawing in of fluid by capillary action or capillarity) of the fluid into the pores of the porous material. In order to promote wicking of the fluid into the pores of the porous material, preferably the porous material also comprises a hydrophilic material, which may be provided, for example, by the porous material itself with or without post treating (e.g. plasma surface treatment such as hypercleaning, etching or micro-roughening, plasma surface modification of the molecular structure, surface chemical activation or crosslinking), or by a coating provided thereto, such as a surfactant.

As shown in embodiments **5c** and **5d**, and more specifically in FIGS. **22** and **23**, recess **53** comprises a rectangular cross section formed in part by a first side wall, a second opposing side wall and a bottom wall. Furthermore, electrodes **29a-c**, **30a-c** also comprise a rectangular cross-sections, and lateral flow passages **43b** extend through the electrodes. However, in other embodiments of the invention, recess **53** and electrodes **29a-c**, **30a-c** may comprises features and cross-sectional shapes other than that of a rectangle. These various electrosurgical devices are discussed particularly in embodiments **5e-5h** in the following paragraphs. Discussion of embodiments **5e-5h** focuses on one particular electrode of the group **29a-c**, **30a-c**, recess **53**, flow channel **54** and lateral flow passage **43**, as the case may be. However, it should be understood that the features discussed for each embodiment **5e-5h** may equally apply to all the electrodes of the group **29a-c**, **30a-c**, recesses **53**, flow channels **54** and lateral flow passages **43** of the respective embodiment.

In an alternative embodiment, rather than an occlusion formed by a portion of the electrosurgical device **5a** defining at least a portion of the distal end of the central flow passage **41**, an occlusion may completely define the distal end of the central flow passage **41**. As shown in FIG. **24**, for device **5e** distal wall section **25** of liner **45** completely defines the end of the central flow passage **41**. In other words, central flow passage **41** only comprises wide portion **41a** and does not comprise narrow portion **41b** or a central fluid passage exit opening **62**. In this manner, the distal end of the central flow passage **41** comprises a blind end. In other words, the central flow passage **41** does not continue through electrosurgical device **5e**. The distal end of the central flow passage terminates within the confines of the electrosurgical device **5e** and is closed by a portion of the electrosurgical device structure, in this embodiment wall section **25** of liner **45**, forming the distal end of the central flow passage **41**.

As shown in FIG **25**, electrode **30a** of electrosurgical device **5f** comprises a circular cross-sectional shape, preferably with a constant diameter. More

particularly, preferably wire conductor **38a** of wire **21a** comprises electrode **30a**. In this manner, conductor **38a** and electrode **30a** comprise a unitarily formed piece which reduces complexity. In this embodiment, it should be understood that the thickness of the electrode is equal to the width of the electrode, with both equal to the diameter of the electrode. Furthermore, electrosurgical device **5f** comprises a number of important distinctions from embodiments **5a-5e** disclosed thusfar.

As shown in FIG. **25**, lateral flow passage **43** does not extend through electrode **30a**, and does not have to extend through electrode **30a** before having fluid communication with fluid flow channel **54**, which reduces complexity. As shown, lateral flow passage **43** is located directly beneath fluid flow channel **54**, rather than having electrode **30c** in between. Also as shown, lateral flow passage **43** is at least partially located beneath overlying electrode **30c** with a portion of fluid flow channel **54** located in between.

Also as shown in FIG. **25**, in addition to a portion of fluid flow channel **54** overlying a portion of the electrode **30a** in recess **53**, at least a portion of fluid flow channel **54** underlies a portion of the electrode **30a** and at least a portion of fluid flow channel **54** is located on at least one longitudinal side of a portion of the electrode **30a** in recess **53**. More particularly, as shown in FIG. **25**, a portion of fluid flow channel **54** is located on two longitudinal sides of the electrode **30a** in recess **53**. Thus, with the configuration of electrosurgical device **5f**, fluid flow channel **54** is not limited to only overlying electrode **30a**, but rather can take on a number of different localities within recess **53**, depending on the application.

As shown in FIG. **26**, electrode **30a** of electrosurgical device **5g** also comprises a circular cross-sectional shape, preferably with a constant diameter. Similar to electrosurgical device **5f**, preferably wire conductor **38a** of wire **21a** also comprises electrode **30a**. However, in contrast to electrosurgical device **5f**, lateral flow passage **43** of device **5g** extends through electrode **30a**. In order to better facilitate the formation of lateral flow passage **43** through electrode **30a**, preferably recess **53** is configured to receive and properly seat electrode **30a** therein substantially without any side-to-side movement and prior to the formation of lateral flow passage **43**. As shown, the seat for electrode **30a** in recess **53** comprises a semi-circle of substantially the same width, more specifically diameter, as that of electrode **30a**. Preferably electrode **30a** is first seated in recess **53** without lateral flow passage **43** formed therein, then, once seated, lateral flow passage **43** is formed through electrode **30a** and probe body **26** and liner **45** simultaneously. In a preferred embodiment, lateral flow passage **43** is formed by a laser acting directed at the outer surface of the electrode **30a**.

As shown in FIG. 27, electrode 30a and recess 53 of electrosurgical device 5h comprises a semi-circular cross-sectional shape and no fluid flow channel 54 is present. However, the seating of electrode 30a and the formation of lateral flow passage 43 is preformed similarly to that disclosed for electrosurgical device 5g.

5 As shown in FIG. 28, electrode 30a and recess 53 of electrosurgical device 5i comprises a triangular cross-sectional shape and, similar to electrosurgical device 5h, no fluid flow channel 54 is present. However, as with electrosurgical device 5h, the seating of electrode 30a and the formation of lateral flow passage 43 is preformed similarly to that disclosed for electrosurgical device 5g. In other words,  
10 the seating portion of recess 53 comprises substantially the same size and shape as the seating portion of the electrode 30a.

Another exemplary electrosurgical device of the present invention which may be used in conjunction with the system of the present invention is shown at reference character 5j in FIG 29, and more particularly in FIGS. 29-31. As best  
15 shown in FIG. 30, rather than an occlusion comprising wall section 25 of a liner 45 or a wall section 47 of conductor 30 defining at least a portion of the distal end of the central flow passage 41 as with earlier embodiments, the occlusion defining at least a portion of the distal end of the central flow passage 41 may comprise a wall section 77 of a separately formed plug 61.

20 As shown in FIG. 30, wall section 77 of plug 61 adjacent distal end 27 of the electrosurgical device 5j and probe body 26 partially defines the distal end of the wide proximal portion 41a of the central flow passage 41 (with the proximal end of the distal narrow portion 41b of the central flow passage 41 defining the remainder of the distal end of the wide portion 41a of the central flow passage 41 in this  
25 embodiment). Wall section 77 of plug 61 also narrows the central flow passage 41 from wide portion 41a to narrow portion 41b and defines a narrow central fluid passage exit opening 62. In the above manner, the wall section 77 inhibits fluid flow from wide portion 41a through the narrow portion 41b of the central flow passage 41. In other words, wall section 77 inhibits the amount of fluid 24 exiting from the  
30 central fluid passage exit opening 62 as compared to a situation where wall section 77 would not be used and the central flow passage 41 only would consist of wide portion 41a. In the above manner, at least a portion of the distal end of the central flow passage 41 is defined by an occlusion (i.e. wall section 77) formed by a portion of the electrosurgical device 5j.

35 As best shown in FIG. 30, plug 61 may occlude the distal portion of the liner 45 adjacent distal end 27 of the electrosurgical device 5j and probe body 26 by being at least partially contained within the liner 45 at the distal end 27 of the electrosurgical device 5j and probe body 26. Plug 61 may be fixed relative to probe

body **26** and within liner **45** as a result of being mechanically connected, preferably interference fit (e.g. with compression of the plug **61**) or otherwise fastened (e.g. adhesively bonded) against the wall surface **33** of the liner **45**. Plug **61** preferably comprises an insulative deformable polymer material, such as a flexible elastomer and, in this embodiment, preferably comprises the geometry of a thin, flat, circular member.

As shown in FIG. **30**, where central flow passage **41** continues through plug **61** and comprises narrowed portion **41b**, narrowed portion **41b** may also be configured for the passage an instrument **64** configured to treat tissue (e.g. injection needle, biopsy forceps, polypectomy snare). Preferably, in its nonuse or retracted position, as shown in FIG. **30**, instrument **64** is contained within the wide portion **41a** of the central flow passage **41** within probe body **26** and thereafter, with use, the instrument **64** is extended from the distal end **27** of the electrosurgical device **5j** and probe body **26** when the instrument **64** is extended distally. The instrument **64** (shown as a hollow needle with an open, pointed tip) may be configured to penetrate tissue and enable injection therapy to tissue, such as the administration of a vasoconstrictor, sclerotic or topical anesthetic through the lumen of a needle.

Where instrument **64** comprises a hollow needle, preferably the needle extends proximally in the lumen of tube **45** and the lumen **23** of tube **19**, towards the proximal end of tube **19** and exits the tube **19** through the sidewall thereof prior to the proximal end where it is then attached to an actuator assembly. Other instruments, such as the biopsy forceps, may be configured to retrieve tissue samples, such as for biopsy.

Referring to FIGS. **32** and **33**, in order for instrument **64** to pass distally through the narrow portion **41b** of central flow passage **41**, depending on the relative size of the instrument **64** to the narrow portion **41b** of central flow passage **41**, wall section **77** plug **61** may be configured to deform to facilitate penetration of the plug **61** by the instrument **64** and, as a result, narrow portion **41b** of central flow passage **41** may be configured to correspondingly increase its cross-sectional size of the through increasing diameter from a first cross-sectional area to a second cross-sectional-area. Furthermore, in order to inhibit the loss of fluid **24** through a narrow portion **41b** of central flow passage **41** of increased size, a surface of the wall section **77** of the plug **61** may be configured to correspondingly at least partially seal narrow portion **41b** and central fluid passage exit opening **62** against the outer wall surface of the instrument **64**.

Conversely, once the instrument **64** is retracted proximally from plug **61**, wall section **77** of plug **61** may be configured to return substantially to its pre-deformation configuration, and with the cross-sectional size of the narrow portion

**41b** of the central flow passage **41** returning substantially to its pre-deformation cross-sectional size.

Another exemplary electrosurgical device of the present invention which may be used in conjunction with the system of the present invention is shown at reference character **5k** in FIG **34**, and more particularly in FIGS. **34-36**. As best shown in FIG. **32**, similar to embodiment **5j**, rather than an occlusion comprising wall section **25** of a liner **45** or a wall section **47** of conductor **30** defining at least a portion of the distal end of the central flow passage **41** as with earlier embodiments, the occlusion defining at least a portion of the distal end of the central flow passage **41** may comprise a wall section **77** of a separately formed plug **61**.

In contrast to embodiment **5j**, rather than an occlusion formed by a portion of the electrosurgical device **5k** defining at least a portion of the distal end of the central flow passage **41**, an occlusion may completely define the distal end of the central flow passage **41**. As shown in FIG. **32**, wall section **77** of plug **61** completely defines the end of the central flow passage **41**. In other words, central flow passage **41** only comprises wide portion **41a** and does not comprise narrow portion **41b** or a central fluid passage exit opening **62**. In this manner, the central flow passage **41** is completely closed by a portion of the electrosurgical device structure forming the distal end of the central flow passage **41**.

However, where central flow passage **41** does not continue through plug **61** as a pre-formed opening, an opening comprising narrow portion **41b** and a central fluid passage exit opening **62** may be configured to be formed in plug **61** by the instrument **64** during extension of the instrument **64** through the plug **61**. For example, plug **61** may be configured to be penetrated (e.g. pierced) by the instrument **64** when the instrument **64** extends distally to form an opening therein for the instrument **64** to extend and retract therethrough. Where the plug **61** is configured to be penetrated, the specific area of the plug **61** configured for penetration may include an area of mechanical weakness, such as an area of reduced thickness **65**, to promote tearing and opening in a predetermined area. As shown, the area of reduced thickness **65** comprises a convex shaped recess formed in the proximal side of the plug **61**.

Among other things, the configuration of electrosurgical devices **5j** and **5k** provide that the devices may be used either simultaneously or independently with instrument **64**. For example, once instrument **64**, such as a hollow hypodermic needle with an open, pointed tip, penetrates plug **61** and extends distally from the distal end **27** of the electrosurgical devices **5j** or **5k**, as indicated above, a surface of the opening in the plug **61** penetrated by the needle, either formed prior or simultaneously with the use of the instrument **64**, preferably seals against the

perimeter outer wall surface of the needle to provide a gasket. At this time, electrical power and fluid used with electrosurgical devices **5j** and **5k** from lumen **23** of tube **19** and central and lateral fluid flow passages **41**, **43** may be provided simultaneously to tissue with fluid from the lumen of instrument **64** (e.g. therapeutic hypodermic medication). Alternatively, when using the two functions independently, the electrical power to electrosurgical devices **5j** and **5k**, or both the electrical power and the conductive fluid to electrosurgical devices **5j** and **5k**, may be switched off when medication from instrument **64** is administered.

In addition, among other things, instrument **64** can function as an electrode extended distally from probe body **26**. Where instrument **64** comprises an electrode, preferably the electrode comprises the same alternating electrical charge as electrodes **30a-c** connected to conductor **30**. An electrode which extends distally from probe body **26**, such as instrument **64** is particularly useful to aid in treating tissue located distally end-on or oblique relative to probe body **26**.

When instrument **64** comprises an electrode of the same alternating electrical charge as electrodes **30a-c** connected to conductor **30**, in addition to the electrical array which extends radially around longitudinal axis **31** between adjacent successive poles, an electrical array extends longitudinally between the instrument **64** comprising an electrode and electrodes **29a-c**.

In other embodiments of the present invention, the instrument **64** comprising an electrode may alternatively be used in a monopolar configuration (without electrodes **29a-c**, **30a-c**) with the second electrode located on the patient being treated. In this embodiment, one of the wires going to the bipolar device would instead go to a ground pad dispersive electrode located on the patient's back or other suitable anatomical location.

Another exemplary electrosurgical device of the present invention which may be used in conjunction with the system of the present invention is shown at reference character **5l** in FIG **37**, and more particularly in FIGS. **37-40**. As best shown in FIG. **39**, rather than an occlusion comprising wall section **25** of liner **45**, or a wall section **47** of conductor **30** or a wall section **77** of plug **61** defining at least a portion of the distal end of the central flow passage **41** as with earlier embodiments, the occlusion defining at least a portion of the distal end of the central flow passage **41** may comprise a wall section **22** of the probe body **26**. Also as shown in FIG. **36**, liner **45** has been eliminated.

As shown in FIG. **39**, distal wall section **22** of probe body **26** adjacent distal end **27** of the electrosurgical device **5k** partially defines the distal end of the wide proximal portion **41a** of the central flow passage **41**. Distal wall section **22** of probe body **26** also narrows the central flow passage **41** from wide portion **41a** to narrow

portion **41b** and defines a narrow central fluid passage exit opening **62**. In the above manner, the distal wall section **22** inhibits fluid flow from wide portion **41a** through the narrow portion **41b** of the central flow passage **41**. In other words, distal wall **22** inhibits the amount of fluid **24** exiting from the central fluid passage exit opening **62** as compared to a situation where distal wall **22** would not be used and the central flow passage **41** only would consist of wide portion **41a**. In the above manner, at least a portion of the distal end of the central flow passage **41** is defined by an occlusion (i.e. wall section **22**) formed by a portion of the electrosurgical device **51**.

Similar to embodiments **5j** and **5k**, electrosurgical device **51** may be configured to receive and instrument **64** therein. As with embodiments **5j** and **5k**, instrument **64** may comprise a hollow hypodermic needle with an open, pointed tip, may be configured to treat tissue when extended distally from the distal end **27** of the electrosurgical device **51** and probe body **26**. More specifically, the instrument **64** may be configured to penetrate tissue and provide injection therapy to tissue.

Also similar to embodiments **5j** and **5k**, instrument **64** is configured to pass distally through the narrow portion **41b** of central flow passage **41** of device **51**. Furthermore, similar to embodiment **5j**, narrow portion **41b** and central fluid passage exit opening **62** of device **51** is formed prior to the use of the instrument **64**. However, unlike embodiments **5j** and **5k**, where a surface of narrow portion **41b** of central flow passage **41** formed by wall section **77** of plug **61** preferably seals against the outer wall surface of the instrument **64**, a surface of wall section **22** of probe **26** of device **51** does not seal against the outer side wall surface **66** of portion **94** of instrument **64**. In this manner, fluid **24** may still exit from central fluid passage exit opening **62** during the use of instrument **64**.

In order to enable the distal tissue treatment portion **94** of instrument **64** to pass through narrowed portion **41b** of central flow passage **41** located at the distal end **27** of device **51**, lateral narrow portion **41b** of this exemplary embodiment preferably has a cross-sectional dimension (e.g. diameter) in the range between and including about 0.1 mm to 2 mm (to accommodate hypodermic needles in the range of 12 to 36 gauge) and more preferably has a diameter in the range between and including about 0.45 mm to 0.51 mm (to accommodate a hypodermic needle of 25 gauge).

Also similar to previous embodiments, the central flow passage **41** of device **51** is at least partially occluded distally by an occlusion. In other words, for example, in earlier embodiments the central flow passage **41** is at least partially occluded distally by wall section **25** of liner **45**, wall section **77** of plug **61** or wall section **22** of probe body **26**, with all three wall sections **25**, **77** and **22** comprise a portion of their respective electrosurgical devices. Furthermore, all three wall



sections form at least a portion of and define at least a portion of the distal end of the central flow passage 41.

Also similar to embodiments 5j and 5k, the narrow portion 41b of the central flow passage 41 of device 5l is occluded by an occlusion provided by a portion 94 of a separate instrument 64. However, as discussed above, for device 5l, preferably fluid 24 may still exit from central fluid passage exit opening 62 during the use of instrument 64 while for devices 5i and 5j preferably it does not.

However, in distinct contrast from embodiments 5j and 5k, fluid 24 may be provided to device 5l from means other than lumen 23 of tube 19. Where instrument 64 comprises a hypodermic needle, preferably the electrosurgical function of device 5l is used independently of the function of instrument 64. With use, after instrument 64 has administered treated tissue, and its presence is no longer required, instrument 64 may be removed from the central flow passage 41 of electrosurgical device 5l by being withdrawn from electrosurgical device 5l proximally through lumen 23 of tube 19.

After withdrawing instrument 64 from electrosurgical device 5l, narrowed portion 41b of central flow passage 41 located at the distal end 27 of the device 5l may then be at least partially occluded by the distal portion 88 of a second instrument 73 inserted into electrosurgical device 5l through lumen 23 of tube 19. As shown in FIG. 40, second instrument 73 also comprises a hollow tube with a lumen therein.

Continuing with FIG. 40, preferably the distal portion of wide portion 41a comprises a narrowing transition portion over the length of which the cross-sectional dimension and area of the central flow channel 41 decreases from that of the wide portion 41a to that of narrow portion 41b. As shown, the diameter and corresponding cross-sectional area of wide portion 41a of central fluid flow passage 41 narrows to the diameter and corresponding cross-sectional area of narrowed portion 41b over the length of tapered portion 79 which, more particularly comprises a tapered concave conical surface 75. Returning to second instrument 73, the distal portion 88 preferably comprises at least one fluid flow restriction portion which is configured to occlude narrowed portion 41b of central flow passage 41 when second instrument 73 is used in conjunction with electrosurgical device 5l, particularly probe body 26.

More particularly, as shown in FIG. 40, distal portion 88 of second instrument 73 comprises a fluid flow restriction portion 81 which, more particularly comprises a tapered convex conical surface 69. When instrument 73 is positioned for use, the surface 69 of tapered portion 81 of instrument 73 cooperates with the surface 75 of tapered portion 79 of probe body 26, preferably via at least partial

contact, to at least partially occlude flow therebetween and the corresponding inhibit flow from central flow passage exit opening **62**.

In addition to first flow restriction portion **81**, the distal portion **88** of second instrument **73** preferably further comprises a second flow restriction portion **83**  
5 extending distally from fluid flow restriction portion **81** and configured to extend into narrowed portion **41b** of central flow passage **41**. As shown second flow restriction portion **83** comprises a cylindrical portion configured to restrict fluid flow through narrowed portion **41b** when the outer surface **84** of the second flow restriction portion **83** cooperates, preferably via at least partial contact, with the wall  
10 surface **85** of narrowed portion **41b** to at least partially occlude flow therebetween and the corresponding inhibit flow from central flow passage exit opening **62**.

The distal portion **88** of second instrument **73** also preferably comprises a guide portion **86** which extends distally from second flow restriction portion **83**. Guide portion **86** is preferably configured to guide the distal portion **88** of the  
15 second instrument **73** into the wide portion **41a** of the central flow passage **41**, but more particularly configured to guide the distal portion **88** of the second instrument **73** into narrowed portion **41b** of the central flow passage **41**. In addition, upon entering narrowed portion **41b**, guide portion **86** is configured to position tapered portion **81** of second instrument **73** with tapered portion **79** of probe body **26** of  
20 electro-surgical device **17e** in juxtaposed orientation relative to one another. As shown, preferably surface **69** of tapered portion **81** of second instrument **73** and surface **75** tapered portion **79** of probe body **26** comprise non-parallel surfaces such that the two surfaces, when in contact, contact and seal on a point.

As shown, guide portion **86** preferably comprises a generally cylindrical  
25 shape with the distal end **87** of the guide portion **86** preferably having a smooth, blunt contour surface, and preferably comprising a generally domed, hemispherical shape such as that of a semi-circle.

In addition to second instrument **73** comprising a guide portion **86**, the tapered concave conical surface **75** of taper portion **79** of the probe body **26** also  
30 functions as a guide portion when it cooperates with guide portion **86** of second instrument **73** to guide the distal portion **88** of the second instrument **73** from the wide portion **41a** of the central flow passage **41** into the narrowed portion **41b** of central flow passage **41**.

As shown in FIG. **40**, in addition to the distal end **88** of the second  
35 instrument **73** preferably being occluded and providing for occluding narrowed portion **41b** as outlined above, second instrument **73** also preferably comprises at least one fluid outlet passage **95** through the side wall **89** thereof. As shown, second

instrument 73 comprises a plurality of fluid outlet passages 95 configured to provide fluid 24 to central flow passage 41 from lumen 71 of second instrument 73.

In order to inhibit the loss of fluid from central flow passage 41 to the lumen 23 of tube 19, preferably the proximal end of the central flow passage 41 of  
5 electrosurgical device 51 is also occluded such that central flow passage 41 preferably comprises a chamber. As shown in FIG. 40, the outer side wall surface 92 of the second instrument 73 cooperates, preferably via at least partial contact, with the sidewall surface portion 51e of member 51 to at least partially occlude flow and provide a seal therebetween and corresponding inhibit flow from central flow  
10 passage 41 back into lumen 23 of tube 19. More particularly, as shown in FIG. 40, gasket portion 51c which surrounds aperture 51d through which second instrument 73 extends to preferably form a gasket with the outer sidewall surface 92.

In order to guide instrument 64 or instrument 73 from the lumen 23 of tube 19 into central flow passage 41, preferably member 51 comprises a tapered portion  
15 51f which, more particularly comprises a tapered concave conical surface. Tapered portion 51f of member 51 particularly cooperates with guide portion 86 of second instrument 73 to guide the distal portion 88 of the second instrument 73 from the lumen 23 of tube 19 into the wide portion 41a of central flow passage 41.

In still other embodiments, the cross-sectional dimension (e.g. diameter) of  
20 the lumen 23 of tube 19 may be less than or equal to the cross-section dimension of the entrance opening to central flow passage 41 thus eliminating the need for tapered portion 51f.

In order to increase the uniformity of flow from central flow passage 41 to all the lateral fluid flow passages 43, preferably central flow passage 41 fills at least  
25 partially, and more preferably completely, with fluid 24 prior to expelling fluid 24 to the lateral fluid flow passages 43. Consequently, it may be desirable to inhibit fluid exiting fluid outlet passages 95 from entering any lateral fluid flow passages 43 directly as a result of the fluid exit openings 90 of fluid outlet passages 95 being aligned with the fluid entrance openings 91 of lateral fluid flow passages 43.  
30 Preferably when second instrument 73 is positioned for use, preferably the fluid exit openings 90 of fluid outlet passages 95 are at least partially offset (i.e. do not perfectly underlie) from the fluid entrance openings 91 of lateral fluid flow passages 43 such that at least a portion of the fluid provided from fluid outlet passages 95 must flow longitudinally prior to entering lateral fluid flow passages 43.

In the absence of liner 45 to conduct electricity to electrodes 30a-c,  
35 preferably electric connection between conductor 38a of wire 21a and electrodes 30a-c is preferably made via a conductor 93 which comprises a longitudinally directed portion 96 and a laterally directed portion 97 located with connected blind

holes **98** and **99**, respectively. Conductor **93** preferably comprises a wire conductor and is preferably connected at its proximal end to conductor **38a** of wire **21a** and at its distal end to one of the electrodes **30a-c** joined by conductor **30**.

In other embodiments of the invention, the electrosurgical device may  
5 comprise less or more than six electrodes. For example, as shown in FIGS. **41-43**, for electrosurgical device **5m** the conductors **29, 30** are preferably branched into sub-conductors with each comprising two elongated longitudinally directed strip electrodes **29a, 29b**, and **30a, 30b**, which will provide energy to treat tissue. As shown in FIGS. **41-42**, the electrodes are preferably aligned generally parallel with  
10 the longitudinal axis **31** on the peripheral surface of the probe body **26** (comprising exposed probe body surfaces **28** and covered probe body surfaces **52**) and are preferably angularly uniformly distributed, in this embodiment at angular intervals of 90 degrees.

In another embodiment of the invention as shown in FIGS. **44-47**, for  
15 electrosurgical device **5n** the conductors **29, 30** are not branched into an additional number of sub-conductors to provide energy to treat tissue, but rather the strip electrodes **29a, 29b** are circumferentially directed and extend around the perimeter of the probe body **26** in a spiral configuration. In other words, as the circumferentially directed electrodes for device **5n** extend around the perimeter of  
20 the probe body **26** they also simultaneously advance longitudinally on the probe body **26**. Also as shown in FIG. **46**, liner **45** has been eliminated, as well as narrow portion **41b** of central flow passage **41** and central flow passage exit opening **62**.

In another embodiment of the invention as shown in FIGS. **48-50**, similar to  
25 embodiment **5n**, for electrosurgical device **5o** the conductors **29, 30** are not branched into an additional number of sub-conductors to provide energy to treat tissue. However, rather the strip electrodes **29a, 29b** circumferentially directed and extending around the circumference of the probe body **26** in a spiral configuration, electrodes **29a, 29b** of embodiment **5o** are circumferentially directed and extending around the perimeter of the probe body **26** in a closed circular hoop configuration.  
30 In other words, as the circumferentially directed electrodes for device **5o** extend around the perimeter of the probe body **26** they do not advance longitudinally on the probe body **26**.

In another embodiment of the invention as shown for device **5p** in FIGS. **51-53**, the electrode configuration comprises a combination of longitudinally directed  
35 electrodes and circumferentially directed electrodes. Furthermore, section **25** has been eliminated from liner **45**.

As shown in FIGS. **51-53**, longitudinally directed electrodes **29a, 30a** are used in combination with circumferentially directed electrodes **29d-29g** and **30d-**

30g, respectively. More particularly electrodes **29d-29g** and **30d-30g** comprise a partial or open circular hoop configuration. As shown each circular hoop configuration comprises a circular length corresponding to about 140 degrees around longitudinal axis **31**. However, the circular hoop configuration may comprise a circular length corresponding to about 10 degrees to 170 degrees around longitudinal axis **31**. Preferably the circular hoop configuration comprise a circular length corresponding to at least 80 degrees around longitudinal axis **31**. Also as shown, electrodes **29d-29g** and **30d-30g** extend from electrodes **29a, 29b** at substantially at right angle and on the outer tissue interacting surfaces **28** of the electrosurgical device **5p** and terminate prior to intersection with the opposite longitudinally directed electrode.

Also as shown, preferably the circumferentially directed electrodes extend circumferentially around the probe body **26** from both opposing longitudinal sides of a longitudinally directed electrode. Furthermore, preferably the circumferentially directed electrodes on each side of the longitudinally directed electrode are aligned along the longitudinal length of the longitudinal electrode. For example, electrodes **30d** and **30e** extend circumferentially around the probe body **26** from both opposing longitudinal sides of a longitudinally directed electrode **30a**. Furthermore, electrodes **30d** and **30e** are aligned along the longitudinal length of longitudinal electrode **30a**.

In the above manner, preferably a single circular hoop configuration comprising a circular length double to the circular length of electrodes **30d** and **30e** individually is formed. In other words, the circular length of electrodes **30d** and **30e** combined corresponds to about 300 degrees around longitudinal axis **31** is formed. However, circular hoop configuration may comprise a circular length corresponding to about 20 degrees to 340 degrees around longitudinal axis **31**. Preferably the circular hoop configuration comprise a circular length corresponding to at least 160 degrees around longitudinal axis **31**.

In contrast to the earlier disclosed embodiments, as shown in FIG. **54**, electrosurgical device **5q** is connected adjacent the distal end **18** of a rigid, self-supporting, hollow tube **19** (as opposed to the flexible tube of earlier disclosed embodiments) which form a shaft. Device **5q** may comprise any of the electrosurgical devices (e.g. **5a-5p**) disclosed herein. Also, as shown in FIG. **54**, tube **19** is in turn connected to a proximal handle, preferably comprising two mating portions **100a, 100b**. Handle **100a, 100b** is preferably made of a sterilizable, rigid, and non-conductive material, such as a polymer (e.g. polycarbonate).

As with the other electrosurgical devices described within, a input fluid line **4b** and a power source, preferably comprising generator **6** preferably providing RF

power via cable **9**, are preferably fluidly and electrically coupled, respectively, to the electrosurgical device **5q**.

With respect to the fluid coupling, fluid **24** from the fluid source **1** for use with electrosurgical device **5q** preferably is communicated from fluid source **1** through a flexible, polyvinylchloride (PVC) outlet fluid line **4a** to a flexible, polyvinylchloride (PVC) inlet fluid line **4b** connected to the electrosurgical device **5q**. The outlet fluid line **4** and the inlet fluid line are preferably connected via a male and female mechanical fastener configuration, preferably comprising a Luer-Lok® connection from Becton, Dickinson and Company. The lumen of the inlet line is then preferably interference fit over the outside diameter of the tube **19** to provide a press fit seal there between. Additionally an adhesive may be disposed there between to strengthen the seal. Fluid is then communicated down the lumen **23** of the tube **19**.

With respect to the electrical coupling, electrosurgical device **5q** is preferably connected to the conductors **38a**, **38b** of insulated electrical wires **21a**, **21b**, respectively, which have been passed through lumen **23** of tube **19** after being spliced into the lumen of the polyvinylchloride (PVC) inlet fluid line as branches from cable **9** which is connected to generator **6**.

As shown in FIG. **54**, preferably the longitudinal axis **31** of electrosurgical device **5q** is preferably configured at an angle relative to the longitudinal axis of tube **19**. Preferably the longitudinal axis **31** of electrosurgical device **5q** is configured at an angle of about 5 degrees to 90 degrees relative to the longitudinal axis of tube **19**. More preferably, the longitudinal axis **31** of electrosurgical device **5q** is configured at an angle of about 8 degrees to 45 degrees relative to the longitudinal axis of tube **19**.

In light of embodiments **5a-5q**, the preferred electrosurgical device of the present invention may vary with application and use. For example, embodiments of devices with circumferentially directed fluid flow channels (e.g. **5n-5p**) are generally preferred over embodiments predominately comprising longitudinally directed fluid flow channels (e.g. **5a-5m**) when the longitudinal axis **31** of the devices are used in a substantially horizontal orientation. As shown in FIG. **55**, device **5p** is being used in a substantially horizontal orientation with cylindrical portion **32** the device **5p** shown adjacent tissue **20** in a semi-circular tissue well **101**, as shown encompassing about 180 degrees of the electrosurgical device **5p**. However, in other embodiments, the semi-circular tissue well **101** may encompass more or less than 180 degrees of the electrosurgical device.

As shown in FIG. **55**, a thin film of fluid **24** is provided from electrosurgical device **5p** and exists between electrosurgical device **5p** and tissue surface **102** near

the bottom of well **101**. However, tissue **20** overlies and occludes the portion **55a** of the opening **55** of fluid flow channel **54** located within the well **101** adjacent tissue **20**, while the fluid flow channel **54** itself remains unoccluded. Consequently, while tissue **20** inhibits fluid **24** from exiting fluid flow channel **54**, it does not prevent  
5 fluid **24** in channel **54** from flowing within the confines of the channel **54**. Thus, as the fluid flow channel **54** and opening **55** extend circumferentially around electro-surgical device **5p**, with the portion **55b** becoming unoccluded as the opening **55** emerges from well **100** and is no longer adjacent tissue **20**, fluid **24** may then exit the fluid flow channel **54** at the tissue surface **102** adjacent the well **101**.

10 Conversely, embodiments of devices with longitudinally directed fluid flow channels (e.g. **5a-5m**) are generally preferred over embodiments predominately comprising circumferentially directed fluid flow channels (e.g. **5o**) when the longitudinal axis **31** of the devices are used in a substantially vertical orientation. As shown in FIG. **56**, device **5c** is being used in a substantially vertical orientation with  
15 cylindrical portion **32** the device **5c** shown adjacent tissue **20** in circular tissue well **102**.

As shown in FIG. **56**, tissue **20** overlies and occludes the portion **55a** of the opening **55** of fluid flow channel **54** located within the circular well **103** adjacent tissue **20**, while the fluid flow channel **54** itself remains unoccluded. Consequently,  
20 while tissue **20** inhibits fluid from exiting fluid flow channel **54**, it does not prevent fluid **24** in channel **54** from flowing within the confines of the channel **54**. Thus, as the fluid flow channel **54** and opening **55** extend circumferentially around electro-surgical device **5c**, with the portion **55b** becoming unoccluded as the opening **55** emerges from well **103** and is no longer adjacent tissue **20**, fluid **24** may then exit  
25 the fluid flow channel **54** at the tissue surface **104** adjacent the well **103**.

Recognizing that the electro-surgical devices of the present invention will potentially be used in both horizontal orientations and vertical orientations, as well as any orientation in between, during their use, the electro-surgical devices of  
30 embodiments **5n** and **5p** may be preferable to certain of the other embodiments disclosed herein.

Another exemplary electro-surgical device of the present invention which may be used in conjunction with the system of the present invention is shown at reference character **5r** in FIG **57**, and more particularly in FIGS. **57-60**. As best shown in FIG. **59**, device **5r** is used in conjunction with instrument **64**. As with  
35 certain other embodiments disclosed herein, instrument **64** is contained within the central flow passage **41** within probe body **26** and thereafter, with use, the instrument **64** is extended from the distal end **27** of the electro-surgical device **5r** and probe body **26** when the instrument **64** is extended distally. Also as disclosed with

other embodiments, the instrument **64** (shown as a hollow needle with an open, pointed tip) may be configured to penetrate tissue and enable injection therapy to tissue, such as the administration of a vasoconstrictor, sclerotic or topical anesthetic through the lumen of a needle.

5           As shown in FIG. **59**, central flow passage **41** comprises a lumen of substantially uniform cross-sectional area and diameter along its length. In addition to the above use for instrument **64** for device **5r**, it serves as an occlusion for occluding central flow passage **41** while a portion of instrument **64** is contained therein. Unlike previous embodiments, central flow passage **41** of device **5r**  
10 preferably does not provide fluid **24** from lumen **23** of tube **19** to lateral flow passage **43a**, **43b**. Rather, fluid **24** from lumen **23** of tube **19** is provided to lateral flow passages **43a**, **43b** through at least one off-center longitudinally directed passage **104** parallel with the longitudinal axis **31** and central flow passage **41**. As shown, preferably passage **104** comprises a plurality of passages **104** angularly  
15 uniformly distributed about the longitudinal axis **31** and central flow passage **41**.

With use of device **5r**, fluid **24** provided from lumen **23** of tube **19** enters longitudinal flow passage fluid entrance opening **105** after the fluid flow is substantially inhibited from entering and flowing through central flow passage **41** due to the presence of instrument **64**.

20           In certain medical procedures, it may be necessary to irrigate a tissue treatment site with a large volume of fluid either before, during or after tissue treatment with the electrosurgical device **5r**. When such irrigation is required, instrument **64** may be retracted proximally from central flow passage **41**, thus leaving central flow passage unoccluded by instrument **64**. Consequently, in  
25 seeking the path of least resistance, fluid **24** from lumen **23** now predominately flows through central flow passage **41** and may be used, for example, to clean a tissue treatment site.

Another exemplary electrosurgical device of the present invention which may be used in conjunction with the system of the present invention is shown at  
30 reference character **5s** in FIG **61**, and more particularly in FIGS. **61-65**. As shown in FIGS. **63-65**, central flow passage **41** and lateral flow passages **43a**, **43b** have been eliminated. Thus, rather than fluid **24** from lumen **23** first flowing through central flow passage **41** and lateral flow passages **43a**, **43b** before reaching fluid flow channel **54**, fluid **24** from lumen **23** of tube **19** flows directly into fluid flow  
35 channel **54**. In other words, as shown in FIGS. **63-65**, fluid flow channel **54** is in direct fluid communication with lumen **23** of tube **19**.

As with other embodiments disclosed herein, fluid flow channels **54** and the electrodes **29a**, **30a** in recesses **53** are substantially coextensive. In other words,



they substantially coincide or are equally extensive in location and boundaries on electrosurgical device **5s**. As shown, in order to facilitate direct fluid communication of fluid flow channels **54** with lumen **23** of tube **19**, preferably fluid flow channels **54** of device **5t** are initiated within the confines of tube **19**. In other words, within the lumen **23** of tube **19** proximal to distal end **18**. As shown, for this embodiment, because the fluid flow channels are initiated within the confines of tube **19**, preferably fluid flow channels **54** and electrodes **29a**, **30a**, are initiated at remote locations. In other words, do not overlie one another in the confines of tube **19**. As shown, for a configuration of two electrodes and two flow channels, preferably the electrical connection for the electrodes and the initiation of the flow channels occurs approximately 90 degrees from one another on electrosurgical device **5s**. In this manner, conductors **29/38b** and **30/38a** are configured to remain electrically insulated from one another (and inhibit a short circuit from there between in the presence of an electrically conductive fluid **24**) by member **51** and the inner surface of the tube **19** which is preferably press fit against shoulder **34**.

Preferably the relationship between the material for the probe body, electrodes and fluid throughout the various embodiments should be such that the fluid wets the surface of the probe body, plugs and/or electrodes to form a continuous thin coating thereon and does not form isolated rivulets or beads. Contact angle,  $\theta$ , is a quantitative measure of the wetting of a solid by a liquid. It is defined geometrically as the angle formed by a liquid at the three phase boundary where a liquid, gas and solid intersect. In terms of the thermodynamics of the materials involved, contact angle  $\theta$  involves the interfacial free energies between the three phases given by the equation  $\gamma_{lv} \cos \theta = \gamma_{sv} - \gamma_{sl}$  where  $\gamma_{lv}$ ,  $\gamma_{sv}$  and  $\gamma_{sl}$  refer to the interfacial energies of the liquid/vapor, solid/vapor and solid/liquid interfaces, respectively. If the contact angle  $\theta$  is less than 90 degrees the liquid is said to wet the solid. If the contact angle is greater than 90 degrees the liquid is non-wetting. A zero contact angle represents complete wetting.

To effectively treat thick tissues, it can be advantageous to have the ability to pulse the RF power on and off. Under some circumstances, the temperature deep in tissue can rise quickly past the 100 °C desiccation point even though the electrode/tissue interface is boiling at 100 °C. This manifests itself as “popping,” as steam generated deep in the tissue boils too fast and erupts toward the surface. In one embodiment of the invention, a switch is provided on the control device or custom generator to allow the user to select a “pulse” mode of the RF power. Preferably, the RF power system in this embodiment is further controlled by software.

In some embodiments, it can be desirable to control the temperature of the conductive fluid before it is released from the electrosurgical device. In one embodiment, a heat exchanger is provided for the outgoing saline flow to either heat or chill the saline. The heat exchanger may be provided as part of the electrosurgical device or as part of another part of the system, such as within the enclosure 14. Pre-heating the saline to a predetermined level below boiling reduces the transient warm-up time of the device as RF is initially turned on, thereby reducing the time to cause coagulation of tissue. Alternatively, pre-chilling the saline is useful when the surgeon desires to protect certain tissues at the electrode/tissue interface and treat only deeper tissue. One exemplary application of this embodiment is the treatment of varicose veins, where it is desirable to avoid thermal damage to the surface of the skin. At the same time, treatment is provided to shrink underlying blood vessels using thermal coagulation. The temperature of the conductive fluid prior to release from the surgical device can therefore be controlled, to provide the desired treatment effect.

In another embodiment, the flow rate controller is modified to provide for a saline flow rate that results in greater than 100% boiling at the tissue treatment site. For example, the selection switch 12 of the flow rate controller 11 (shown in FIG. 1) can include settings that correspond to 110%, 120% and greater percentages of boiling. These higher settings can be of value to a surgeon in such situations as when encountering thick tissue, wherein the thickness of the tissue can increase conduction away from the electrode jaws. Since the basic control strategy neglects heat conduction, setting for 100% boiling can result in 80% or 90% boiling, depending upon the amount of conduction. Given the teachings herein, the switch of the flow rate controller can accommodate any desirable flow rate settings, to achieve the desired saline boiling at the tissue treatment site.

The invention can, in some embodiments, deliver fast treatment of tissue without using a temperature sensor built into the device or a custom special-purpose generator. In a preferred embodiment, there is no built-in temperature sensor or other type of tissue sensor, nor is there any custom generator. Preferably, the invention provides a means for controlling the flow rate to the device such that the device and flow rate controller can be used with a wide variety of general-purpose generators. Any general-purpose generator is useable in connection with the fluid delivery system and flow rate controller to provide the desired power; the flow rate controller will accept the power and constantly adjust the saline flow rate according to the control strategy. Preferably, the generator is not actively controlled by the invention, so that standard generators are useable according to the invention. Preferably, there is no active feedback from the device and the control of the saline

flow rate is "open loop." Thus, in this embodiment, the control of saline flow rate is not dependent on feedback, but rather the measurement of the RF power going out to the device.

For purposes of the appended claims, the term "tissue" includes, but is not limited to, organs (e.g. liver, lung, spleen, gallbladder), highly vascular tissues (e.g. liver, spleen), soft and hard tissues (e.g. adipose, areolar, bone, bronchus-associated lymphoid, cancellous, chondroid, chordal, chromaffin, cicatricial, connective, elastic, embryonic, endothelial, epithelial, erectile, fatty, fibrous, gelatinous, glandular, granulation, homologous, indifferent, interstitial, lymphadenoid, lymphoid, mesenchymal, mucosa-associated lymphoid, mucous, muscular, myeloid, nerve, osseous, reticular, scar, sclerous, skeletal, splenic, subcutaneous), tissue masses (e.g. tumors), etc.

While a preferred embodiment of the present invention has been described, it should be understood that various changes, adaptations and modifications can be made therein without departing from the spirit of the invention and the scope of the appended claims. The scope of the invention should, therefore, be determined not with reference to the above description, but instead should be determined with reference to the appended claims along with their full scope of equivalents. Furthermore, it should be understood that the appended claims do not necessarily comprise the broadest scope of the invention which the Applicant is entitled to claim, or the only manner(s) in which the invention may be claimed, or that all recited features are necessary.

All publications and patent documents cited in this application are incorporated by reference in their entirety for all purposes.

25

**I claim:**

1. A medical device comprising:  
a catheter tube having a distal end and a lumen, the tube configured to assist  
5 in applying tamponage to a bleeding source in a gastrointestinal tract when flexed;  
a catheter tip assembled with the tube adjacent the distal end of the tube, the  
catheter tip having a catheter tip outer surface and including:  
a probe body comprising an electrically insulative material;  
at least one electrode pair, the electrode pair comprising a first  
10 electrode spaced from a second electrode, the first electrode and the second  
electrode located on the probe body;  
a fluid distribution manifold to direct a fluid from inside the probe  
body towards the tip outer surface, the manifold comprises a central passage  
within the probe body and a plurality of lateral passages which extend from  
15 the central passage towards the tip outer surface;  
an injection needle housed within the central passage, the needle extendable  
from the central passage to provide treatment to tissue.
2. The medical device of claim 1 wherein a portion of the catheter tip is  
20 configured to be penetrated by a portion of the needle.
3. The medical device of claim 1 wherein a portion of the catheter tip is  
configured to open around a portion of the needle.
- 25 4. The medical device of claim 1 wherein a portion of the catheter tip is  
configured to least partially seal with a portion of the needle.
5. The medical device of claim 1 wherein a portion of the catheter tip is  
30 configured to electrically insulate the needle from the electrodes.
6. The medical device of claim 1 wherein a portion of the catheter tip provides  
a guide portion for guiding the needle from the lumen of the catheter tube to the  
central passage within the probe body.
- 35 7. The medical device of claim 1 wherein:  
the central passage extends to a central passage outlet opening; and  
a portion of the needle occludes at least a portion of the central passage  
outlet opening whereby a flow of the fluid from the central passage outlet opening

may be inhibited such that a flow of the fluid from at least a portion of the plurality of lateral passages may be increased.

8. The medical device of claim 1 further comprising:  
5 a first electrical connection to the catheter tip;  
a second electrical connection to the catheter tip; and  
a member comprising an electrically insulative portion, the electrically  
insulative portion electrically insulating the first electrical connection from the  
second electrical connection to inhibit a short circuit from forming between the two  
10 connections in the presence of an electrically conductive fluid.
9. The medical device of claim 1 wherein:  
each electrode extends longitudinally along the probe body; and  
the plurality of lateral passages are spaced longitudinally along the probe  
15 body.
10. The medical device of claim 9 wherein:  
at least a portion of the plurality of lateral passages extend to an outlet  
opening located on the tip outer surface; and  
20 the tip outer surface comprises an outer surface of at least one of the first and  
second electrodes.
11. The medical device of claim 1 wherein:  
each electrode extends spirally around the probe body; and  
25 the plurality of lateral passages are spaced spirally around the probe body.
12. The medical device of claim 11 wherein:  
at least a portion of the plurality of lateral passages extend to an outlet  
opening located on the tip outer surface; and  
30 the tip outer surface comprises an outer surface of at least one of the first and  
second electrodes.
13. The medical device of claim 1 wherein:  
each electrode extends circularly around the probe body; and  
35 the plurality of lateral passages are spaced circularly around the probe body.
14. The medical device of claim 13 wherein:

at least a portion of the plurality of lateral passages extend to an outlet opening located on the tip outer surface; and  
the tip outer surface comprises an outer surface of at least one of the first and second electrodes.

5

15. The medical device of claim 1 wherein:  
each electrode extends circumferentially around the probe body; and  
the plurality of lateral passages are spaced circumferentially around the probe body.

10

16. The medical device of claim 15 wherein:  
at least a portion of the plurality of lateral passages extend to an outlet opening located on the tip outer surface; and  
the tip outer surface comprises an outer surface of at least one of the first and second electrodes.

15

17. The medical device of claim 1 wherein:  
each electrode extends both longitudinally and circumferentially around the probe body; and  
the plurality of lateral passages are spaced both longitudinally and circumferentially around the probe body.

20

18. The medical device of claim 16 wherein:  
at least a portion of the plurality of lateral passages extend to an outlet opening located on the tip outer surface; and  
the tip outer surface comprises an outer surface of at least one of the first and second electrodes.

25

19. The medical device of claim 1 wherein the at least one conductor pair comprises two electrode pairs.

30

20. The medical device of claim 1 wherein the at least one conductor pair comprises three electrode pairs.

35

FIG. 1

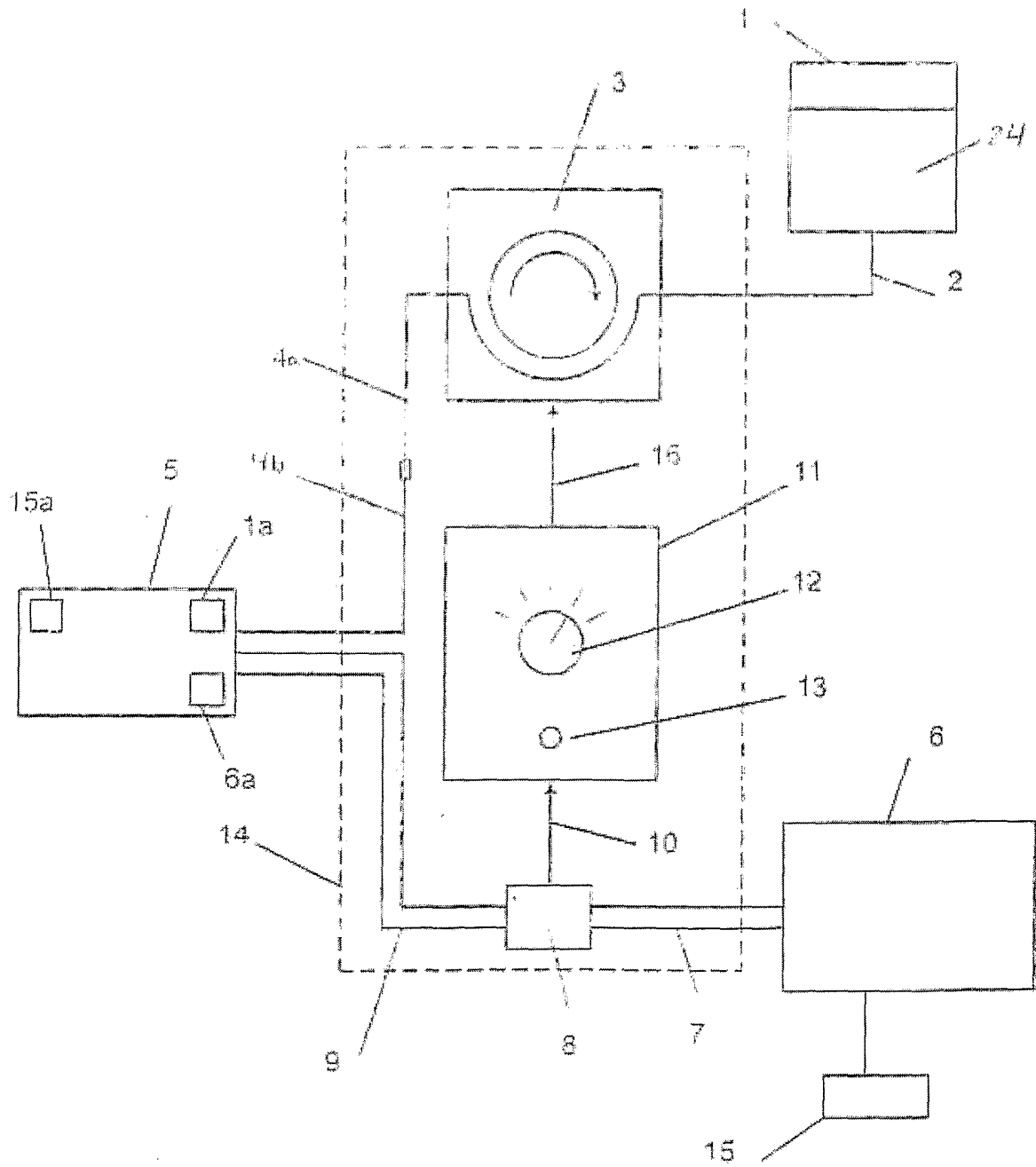

FIG. 2

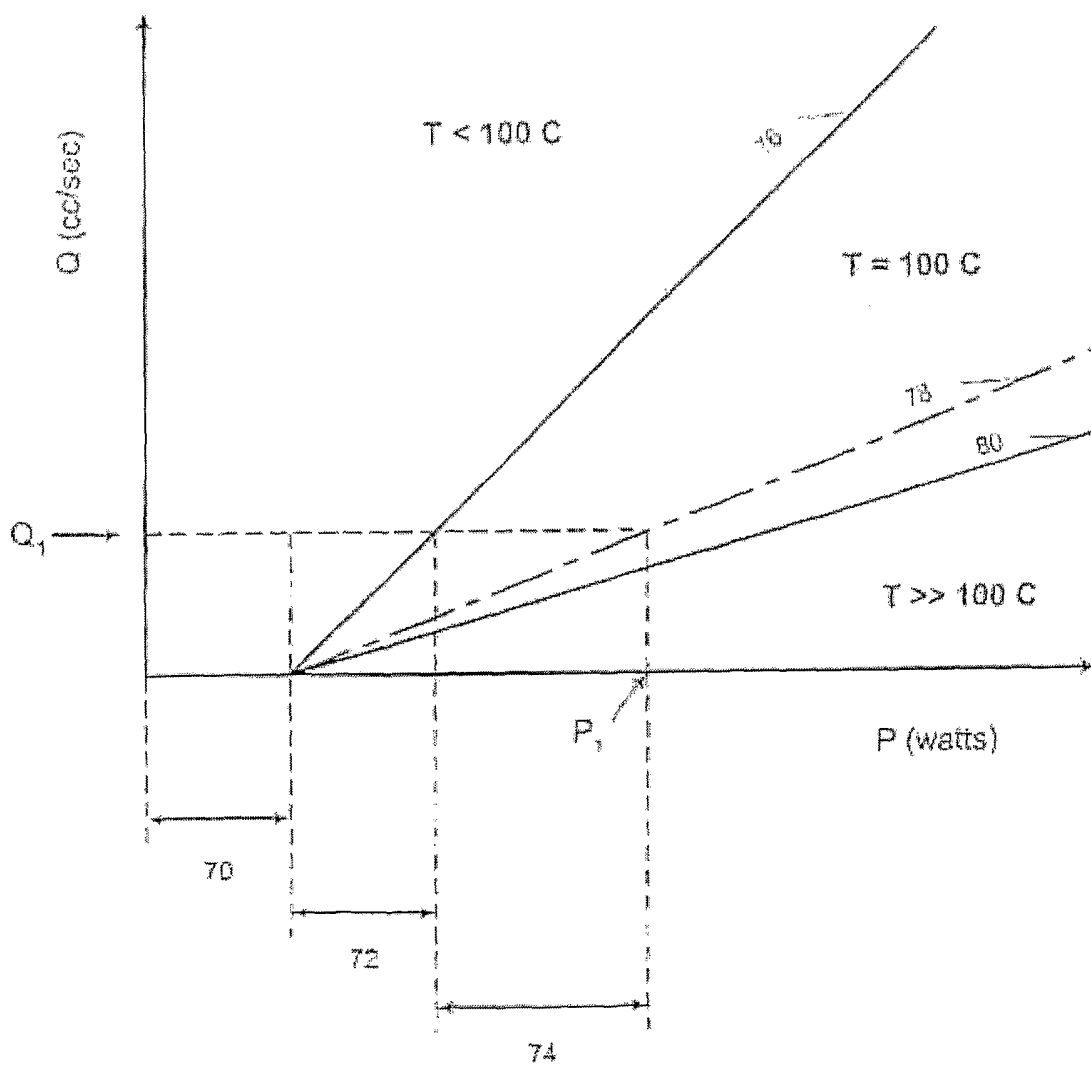



FIG. 2A

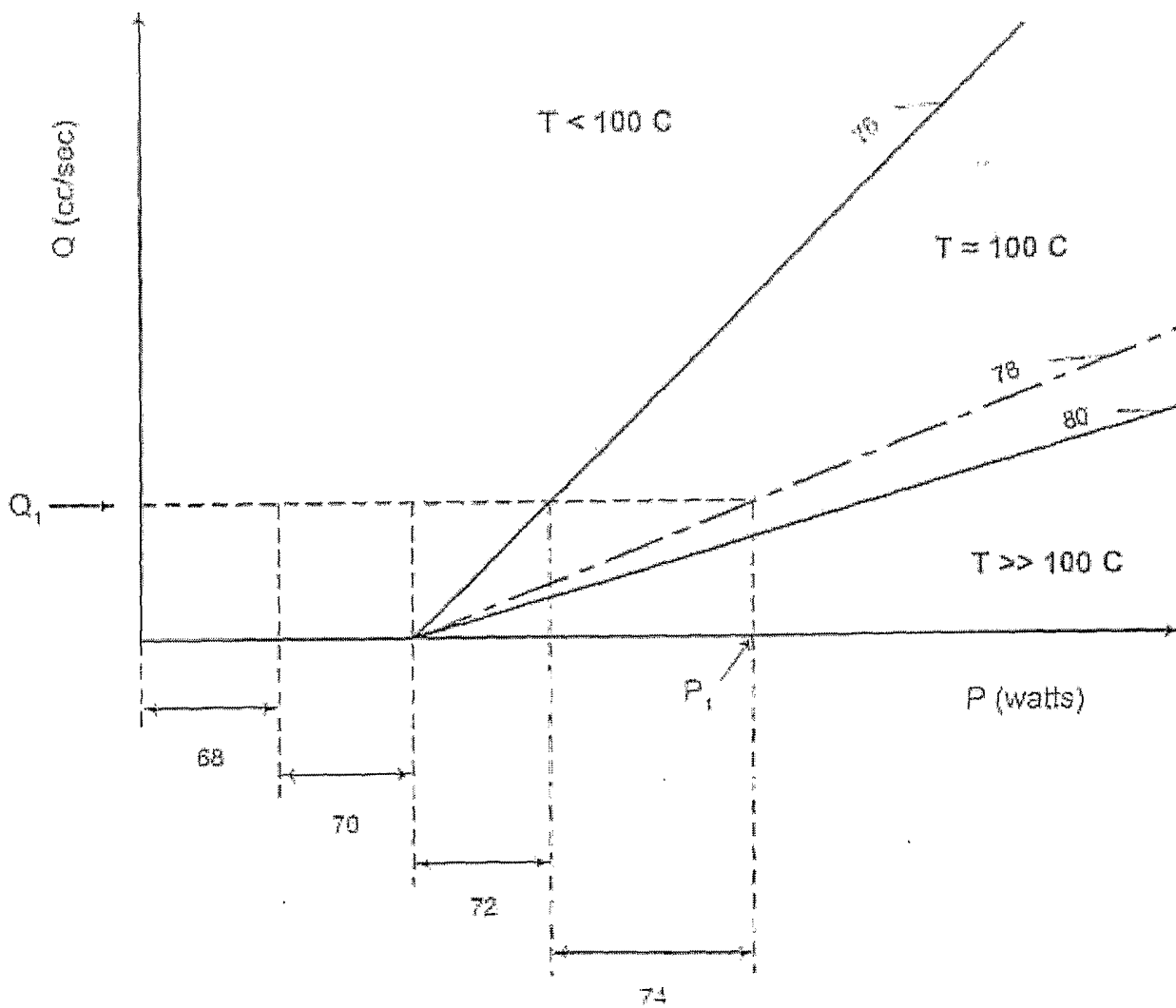

FIG. 3

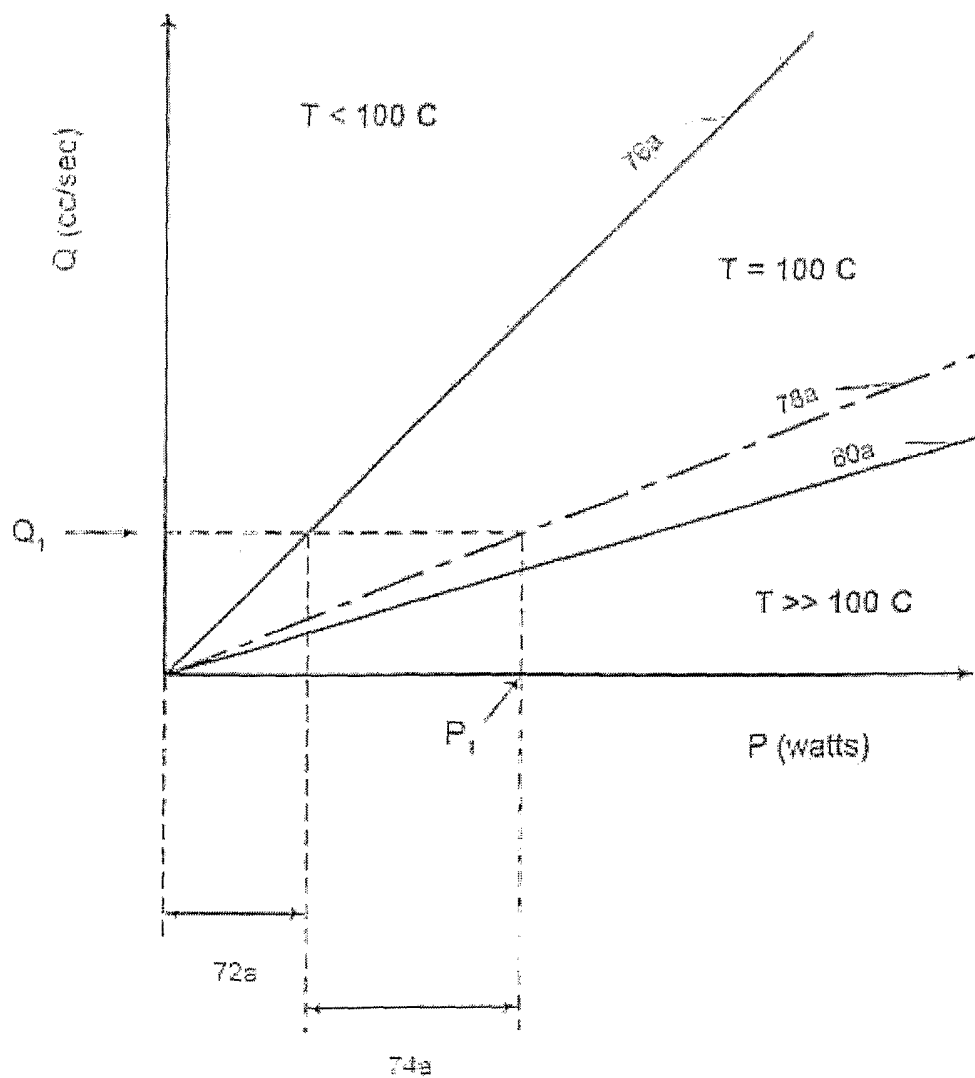

FIG. 4

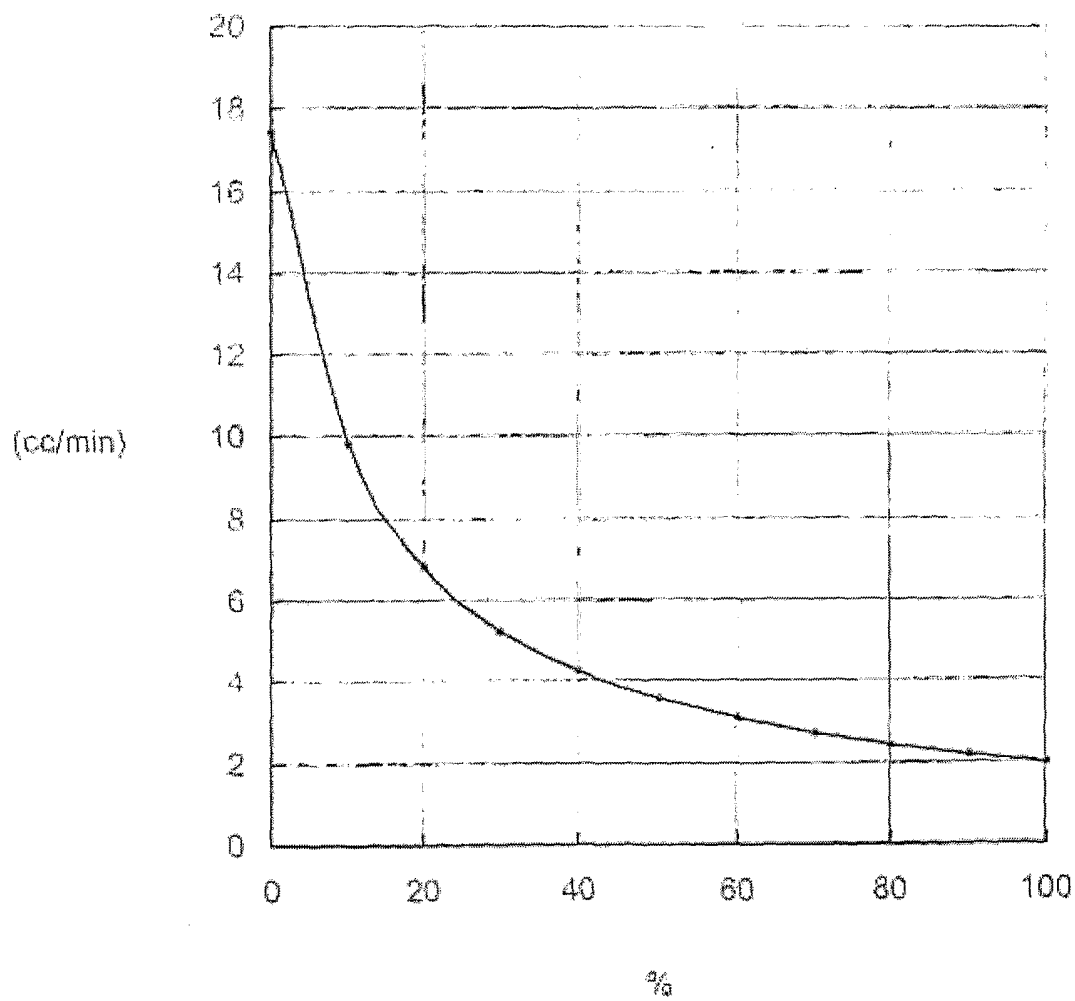

FIG. 5

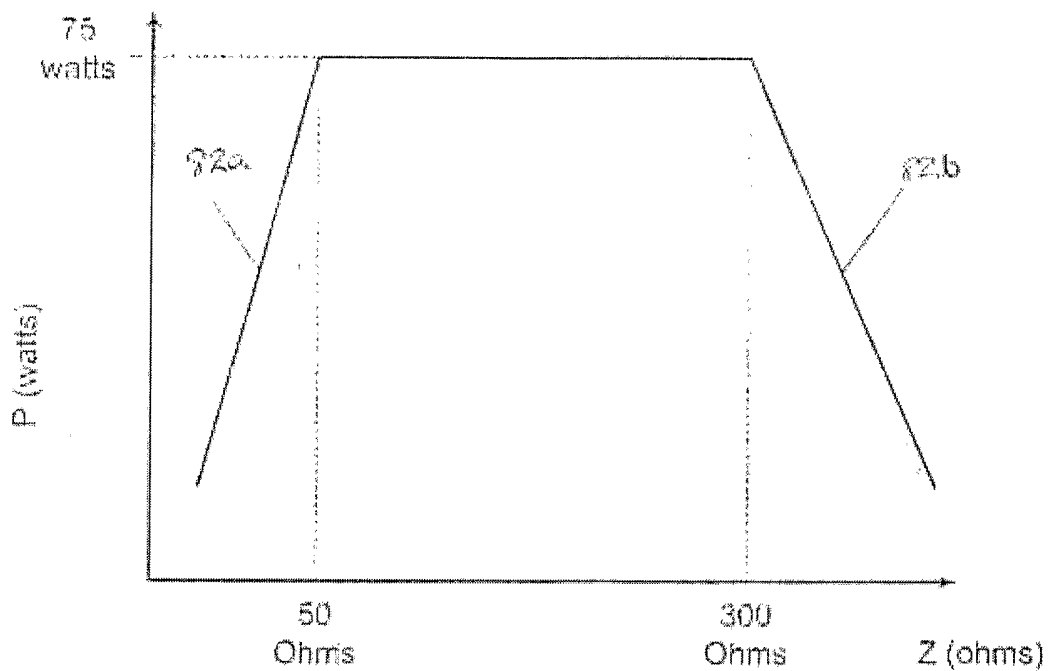
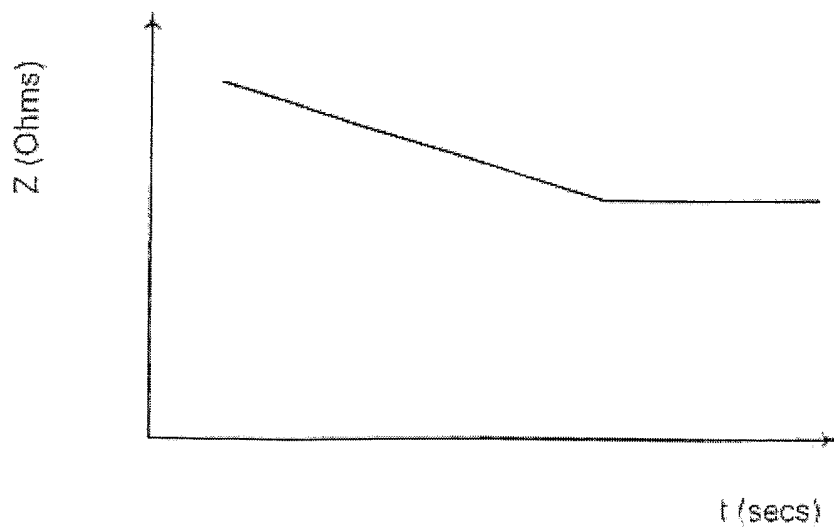

FIG. 6



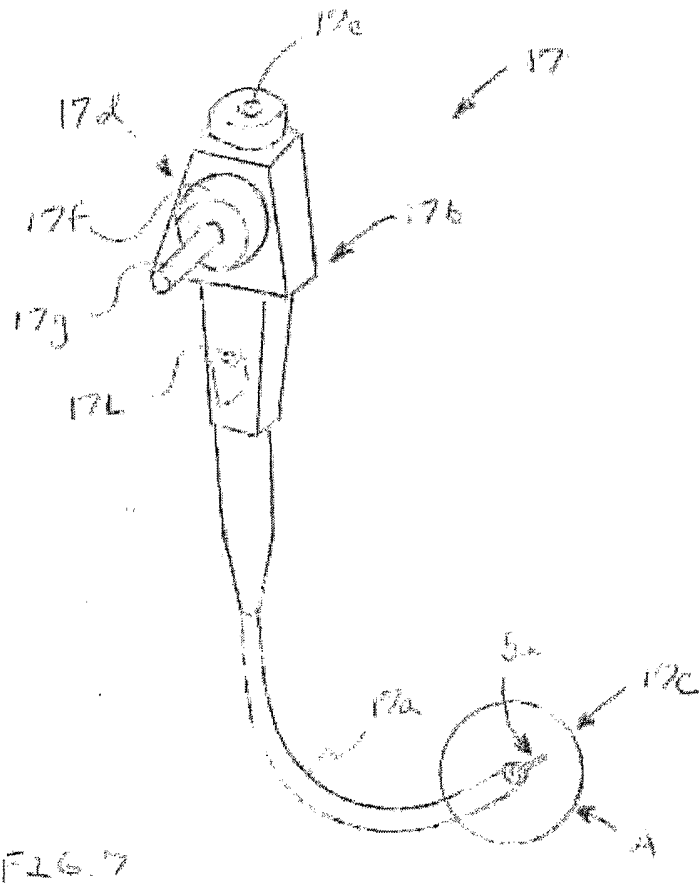

FIG. 7

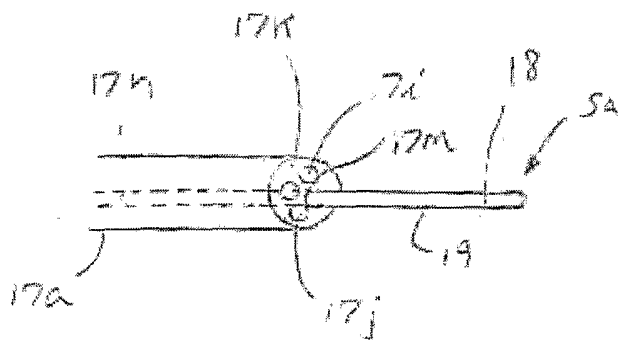

FIG. 8

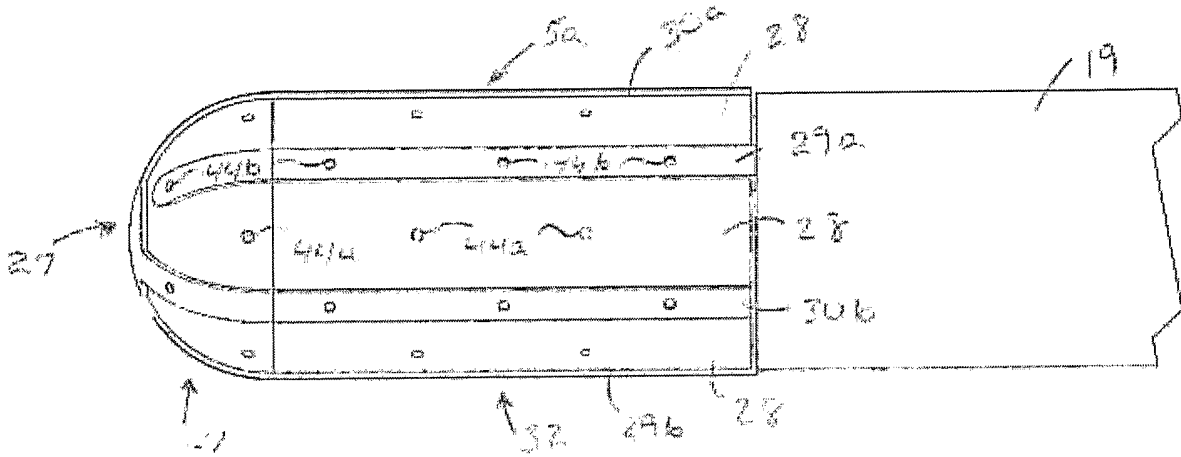

FIG. 11

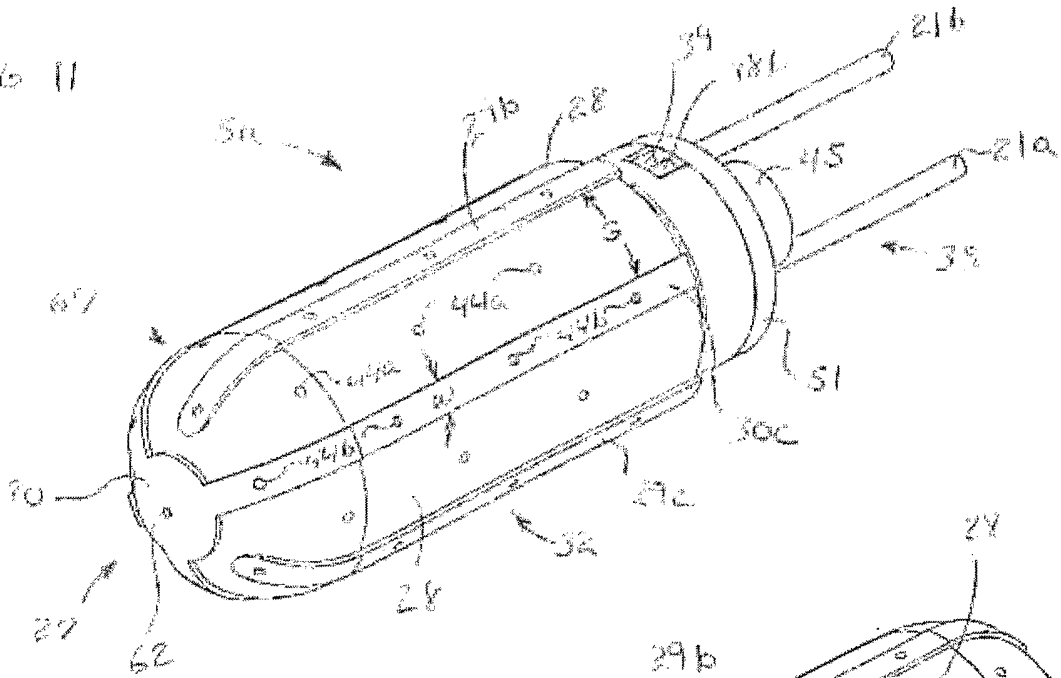

FIG. 9

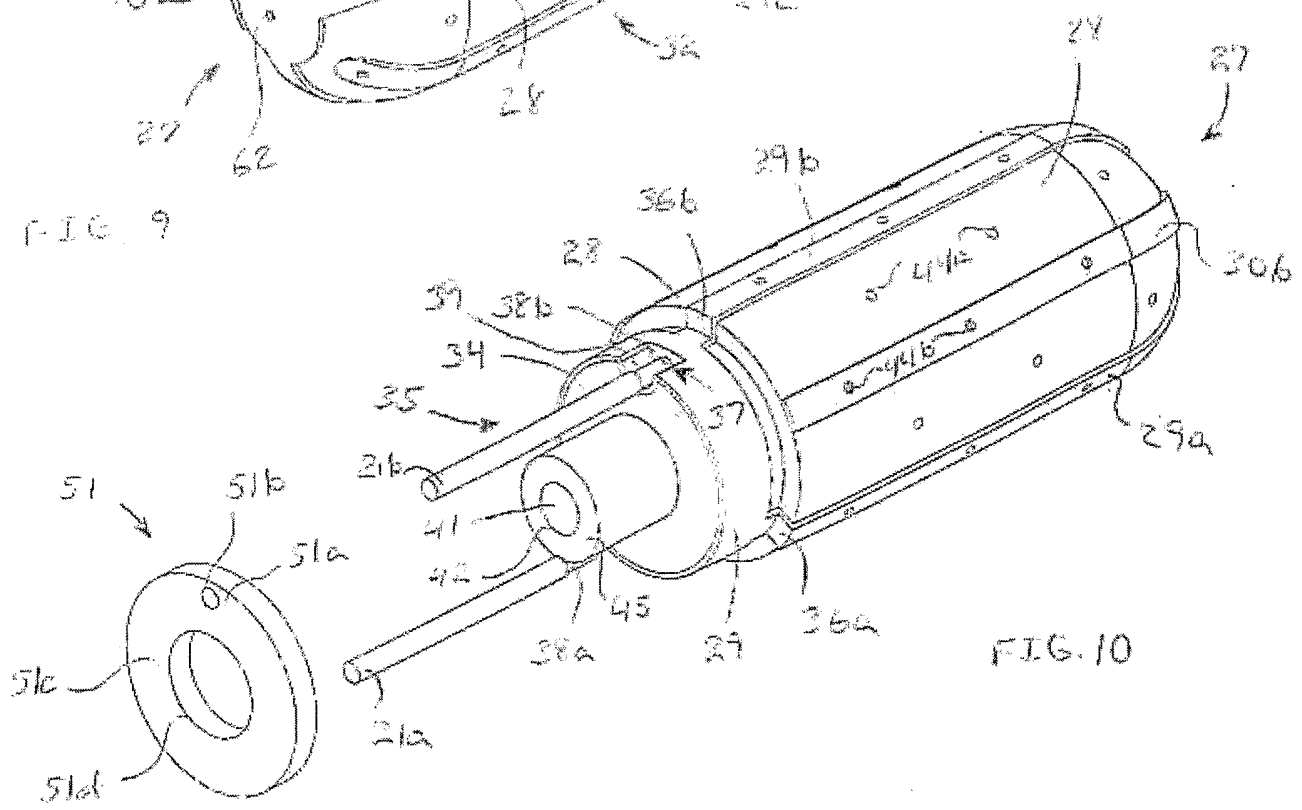

FIG. 10

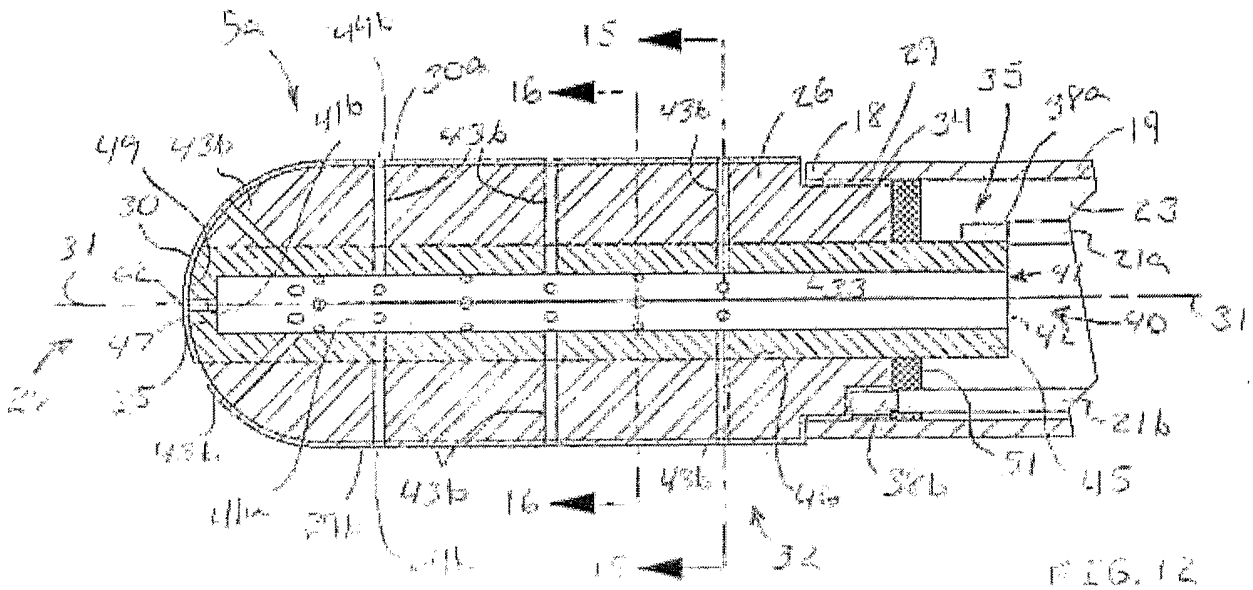

FIG. 12

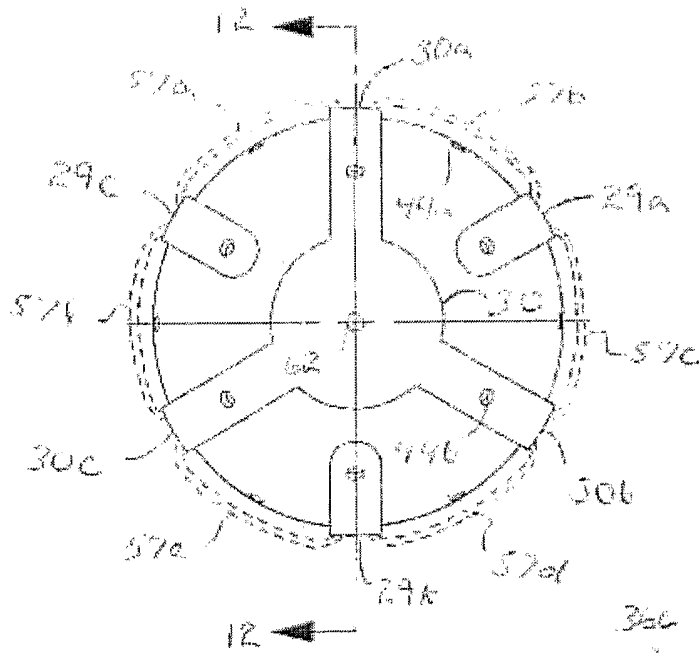
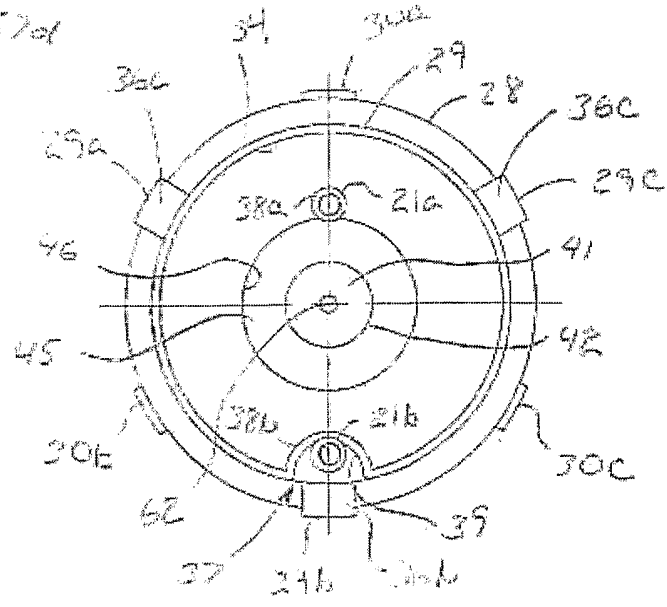

FIG. 13

FIG. 14



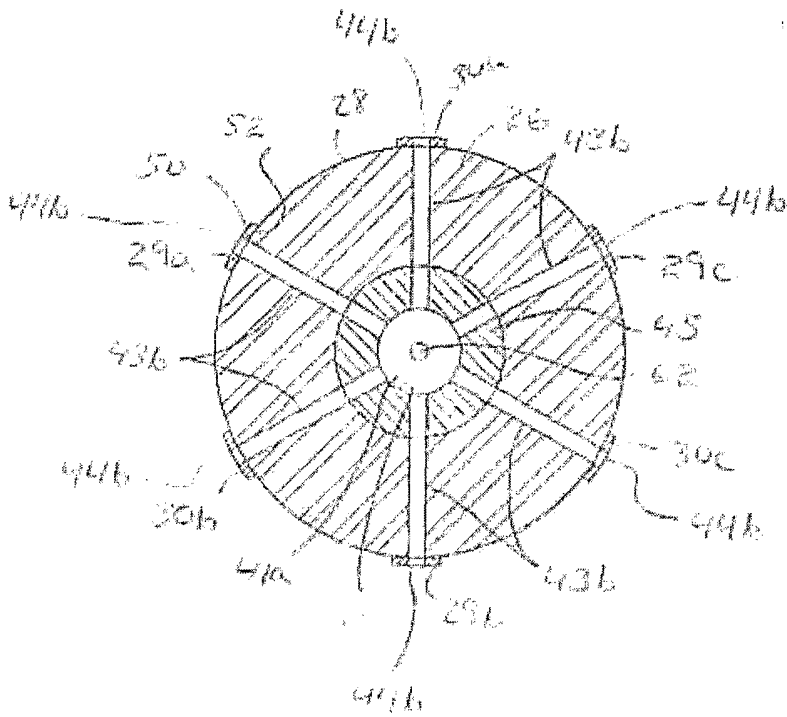

FIG. 15

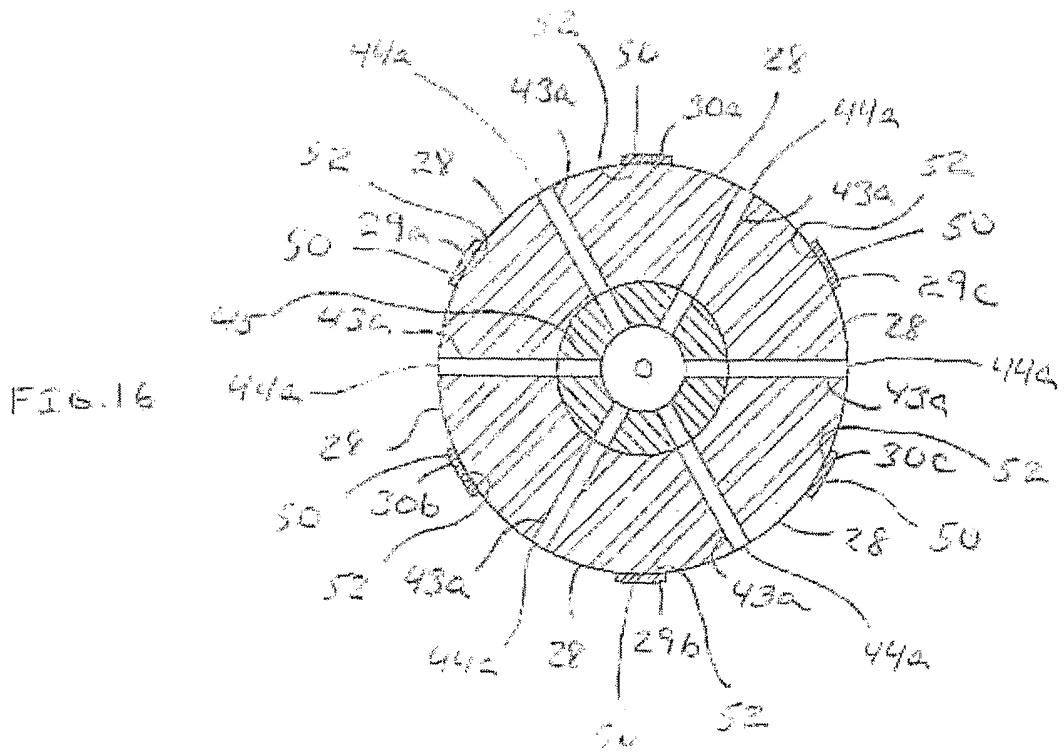

FIG. 16



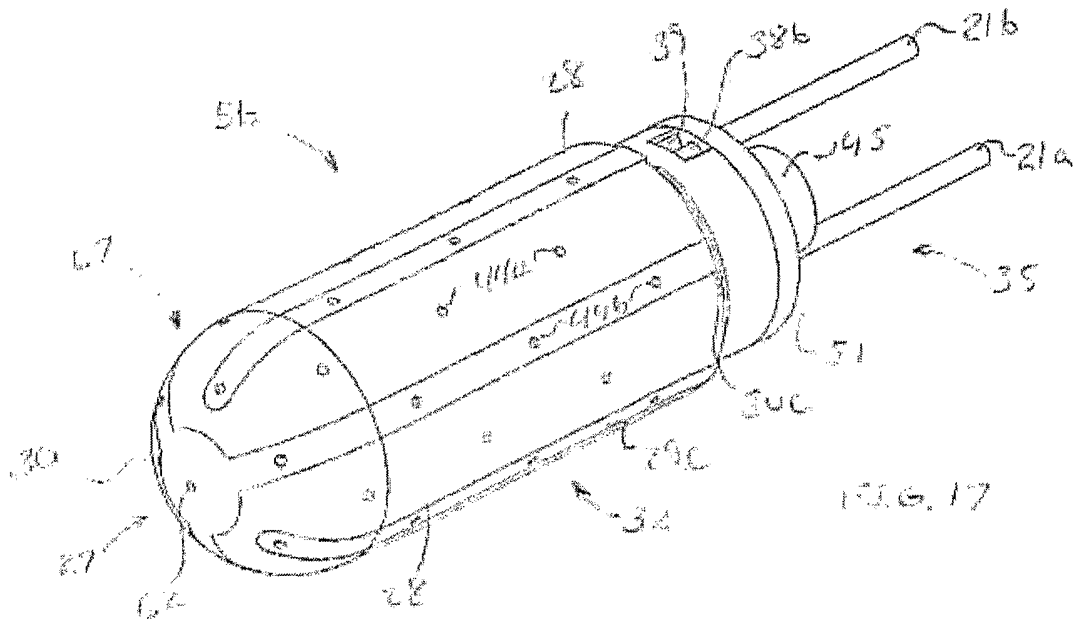

FIG. 17

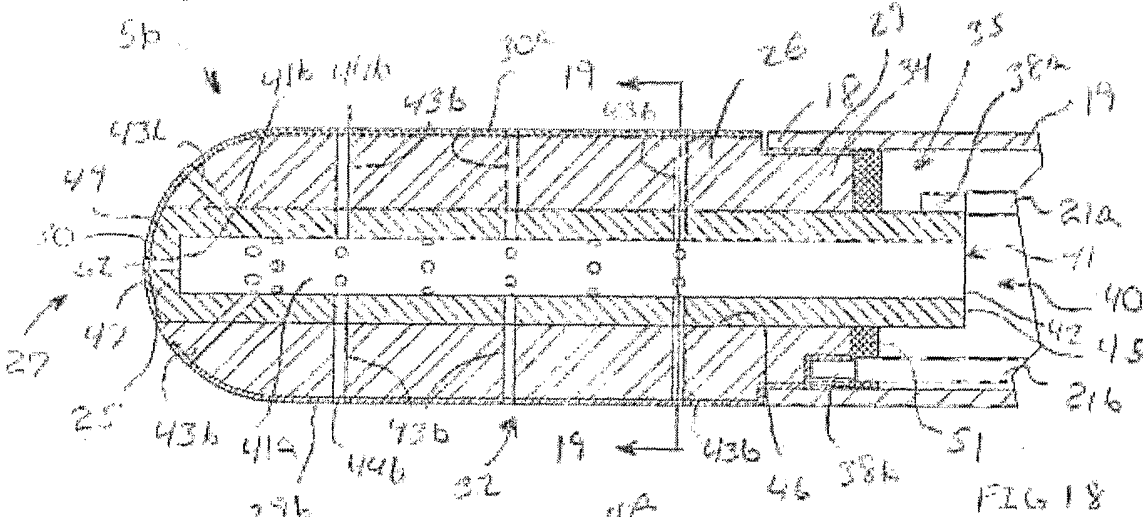

FIG. 18

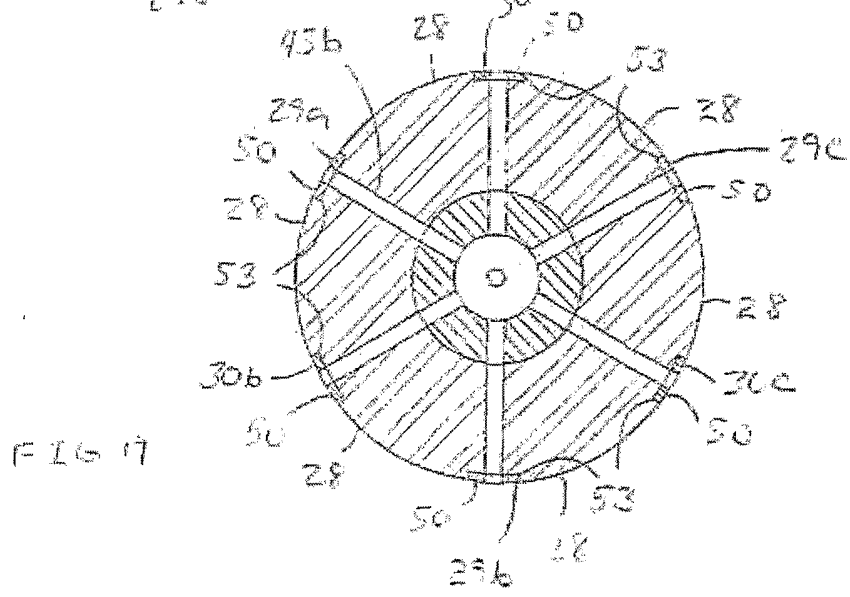

FIG. 19

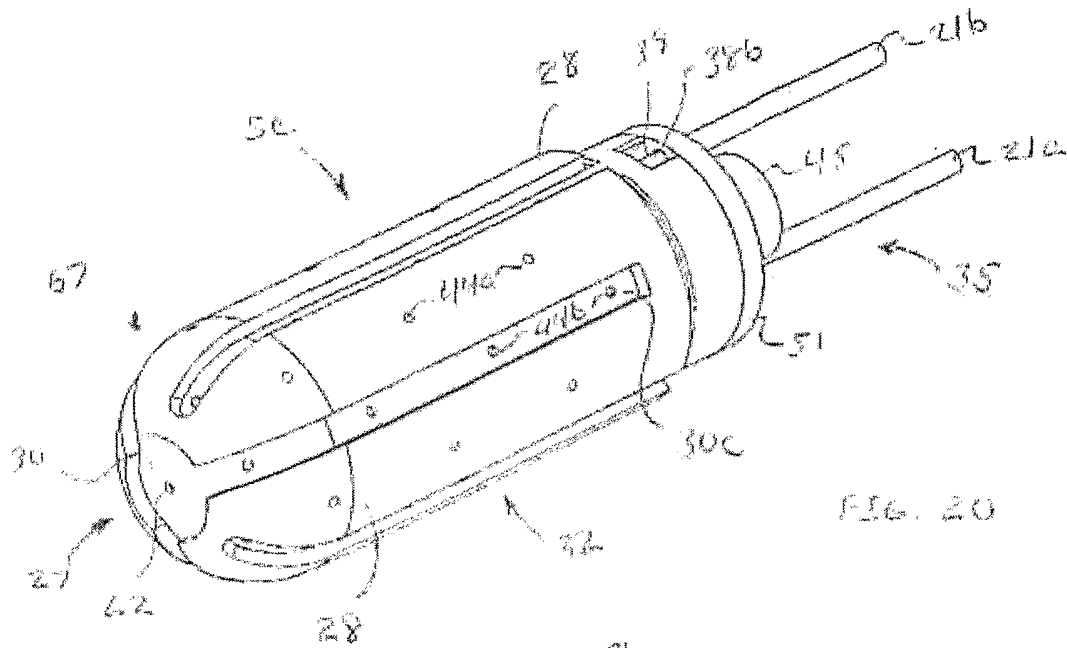

FIG. 20

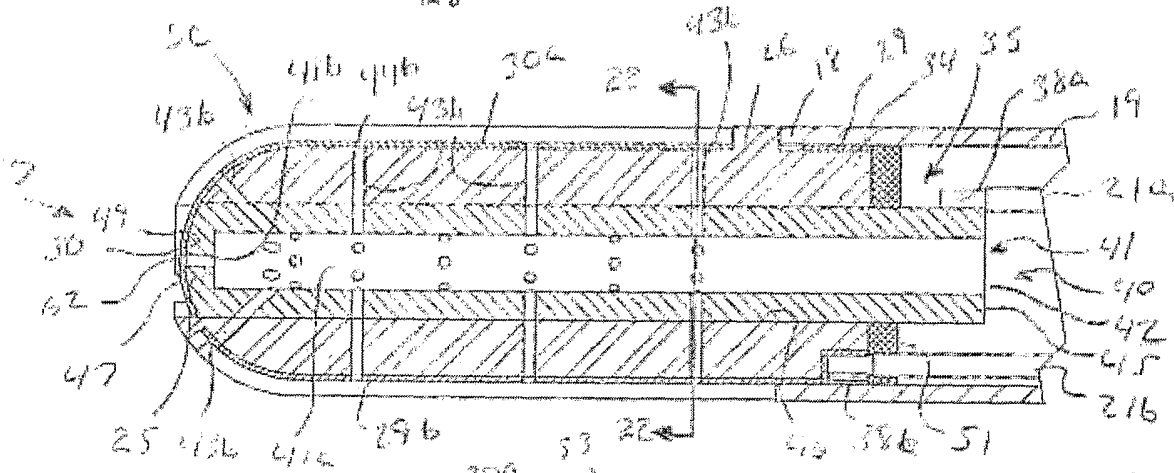

FIG. 21

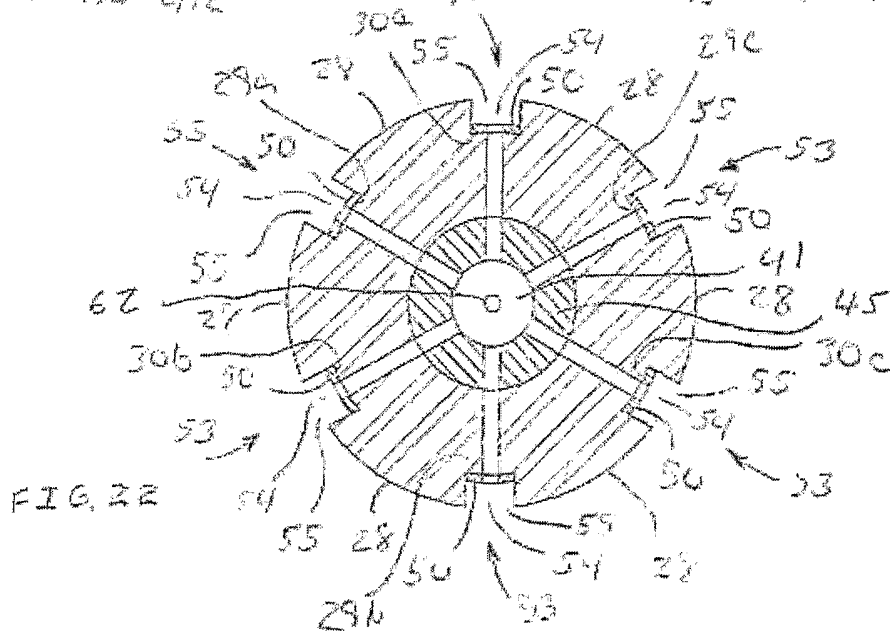

FIG. 22

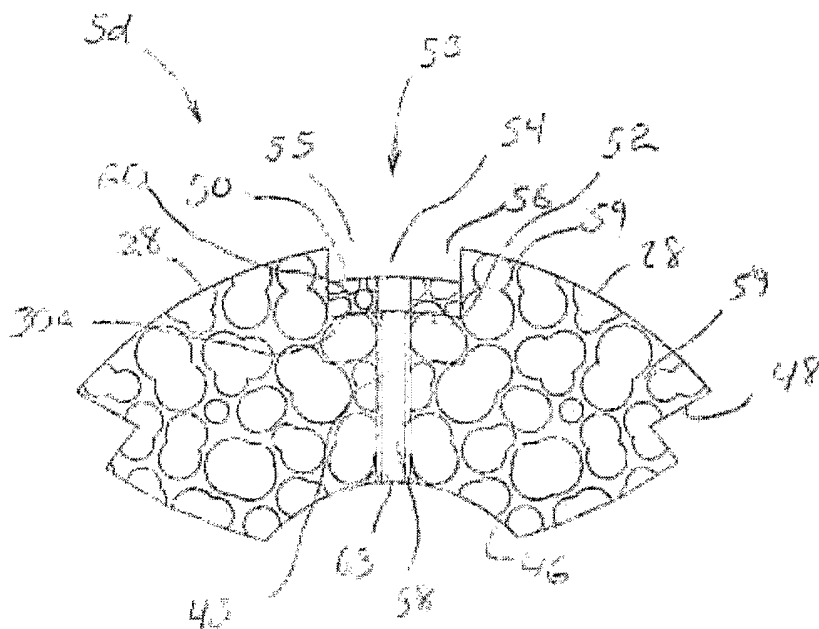

FIG. 23

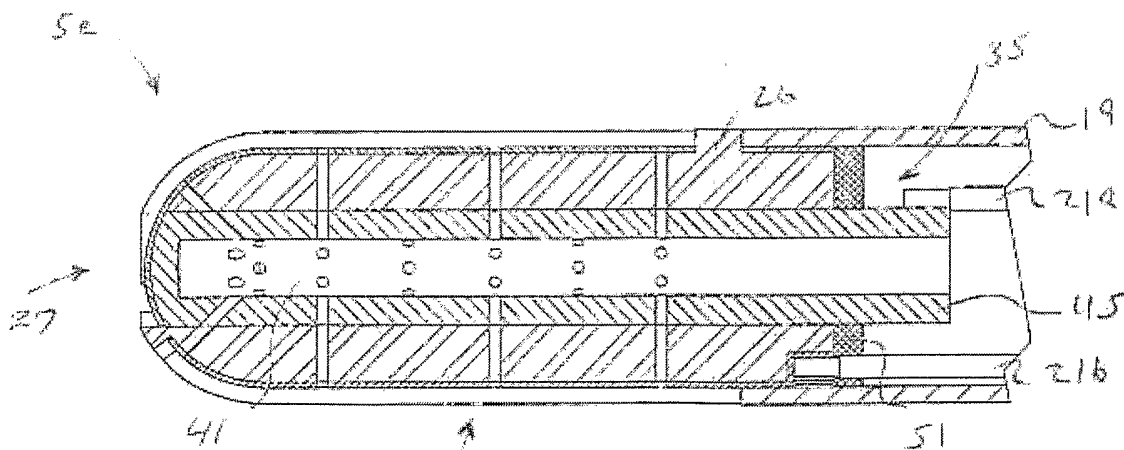

FIG. 24

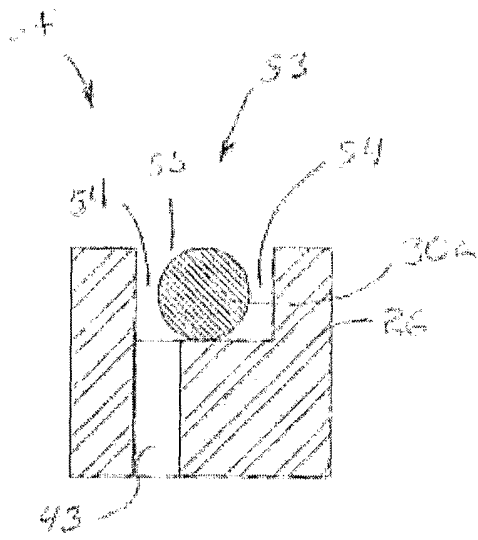

FIG. 65

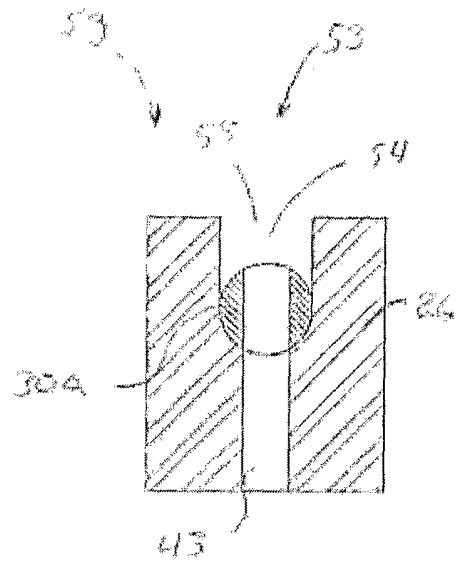

FIG. 76

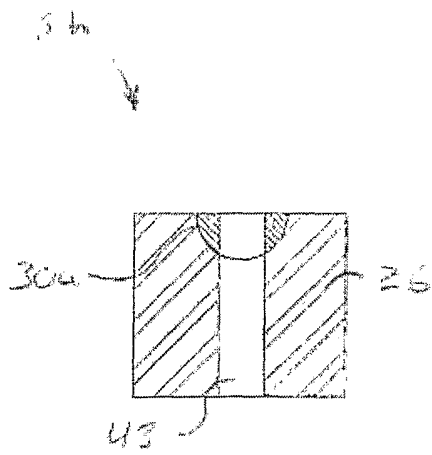

FIG. 27

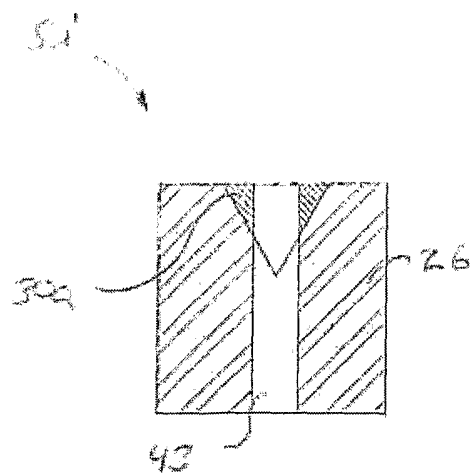

FIG. 28

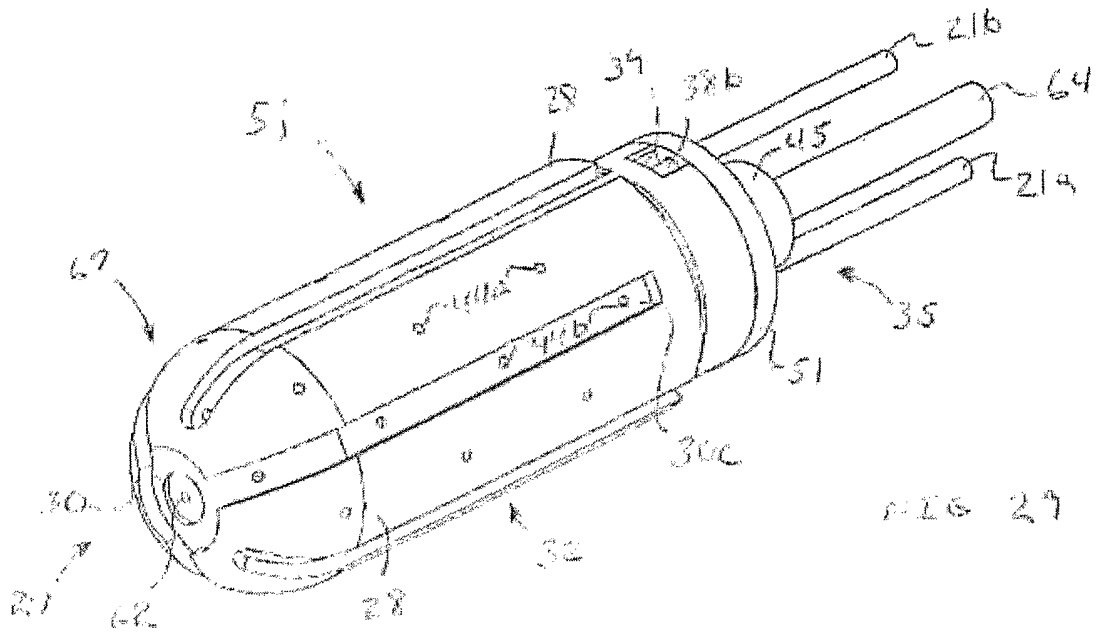

FIG 29

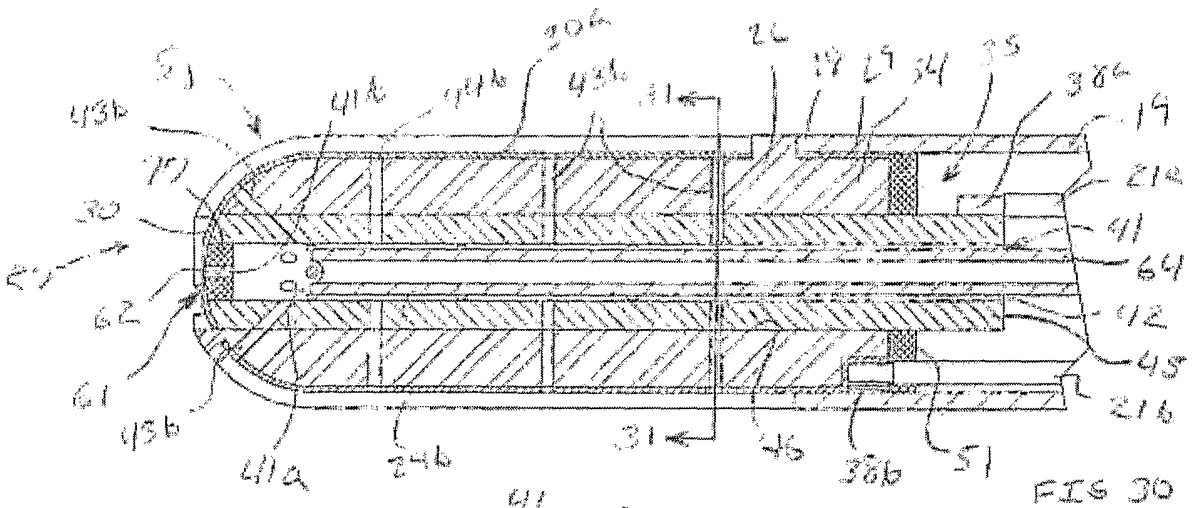

FIG 30

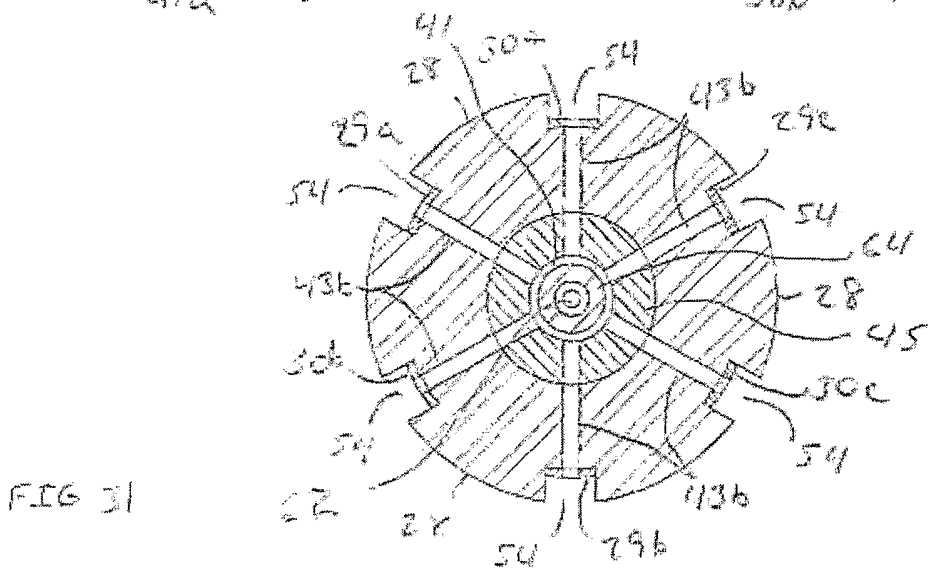
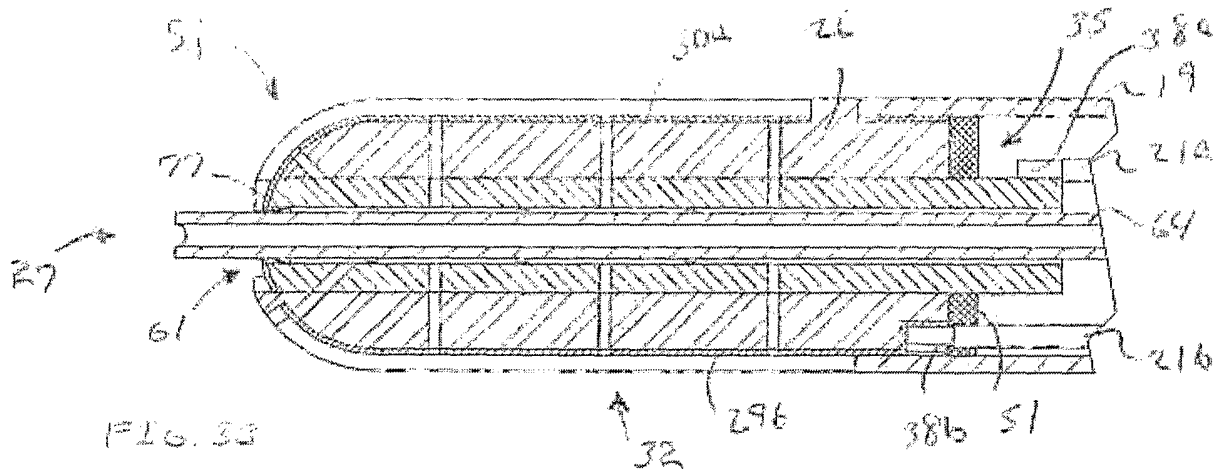
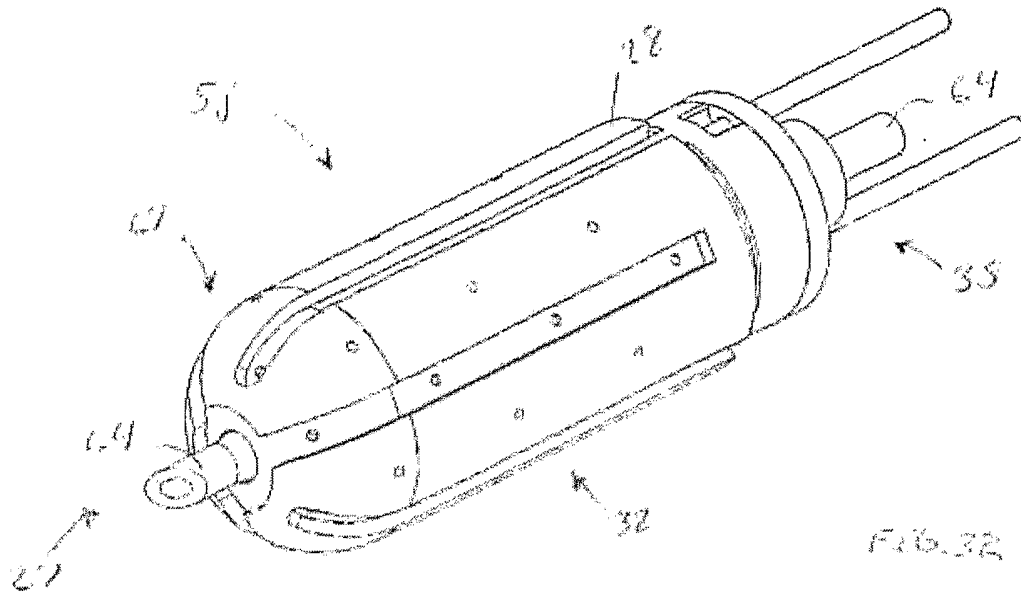
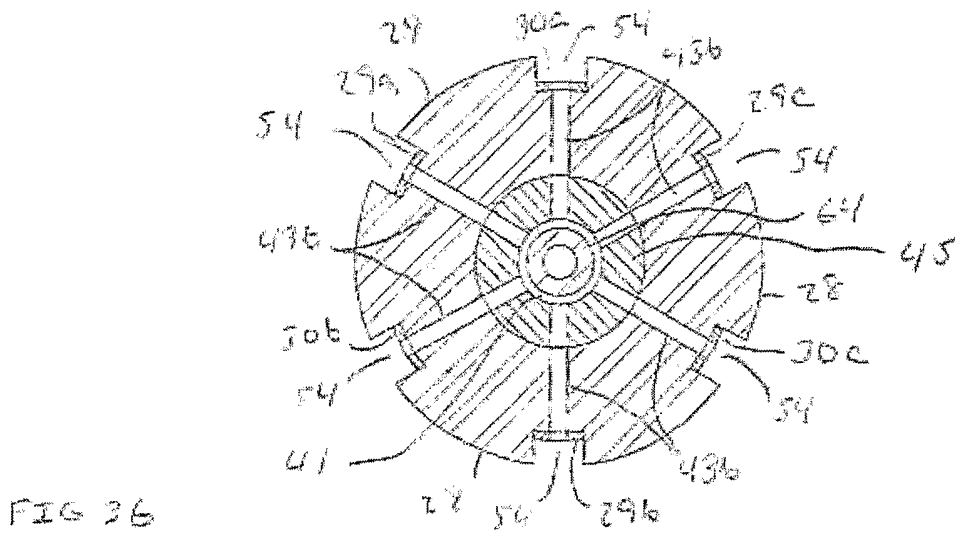
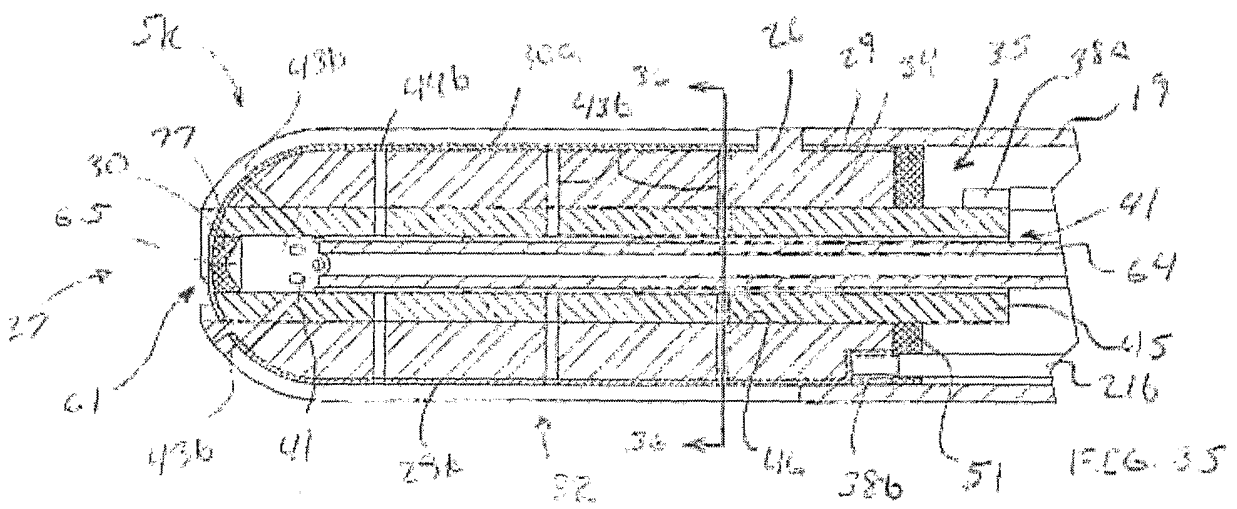
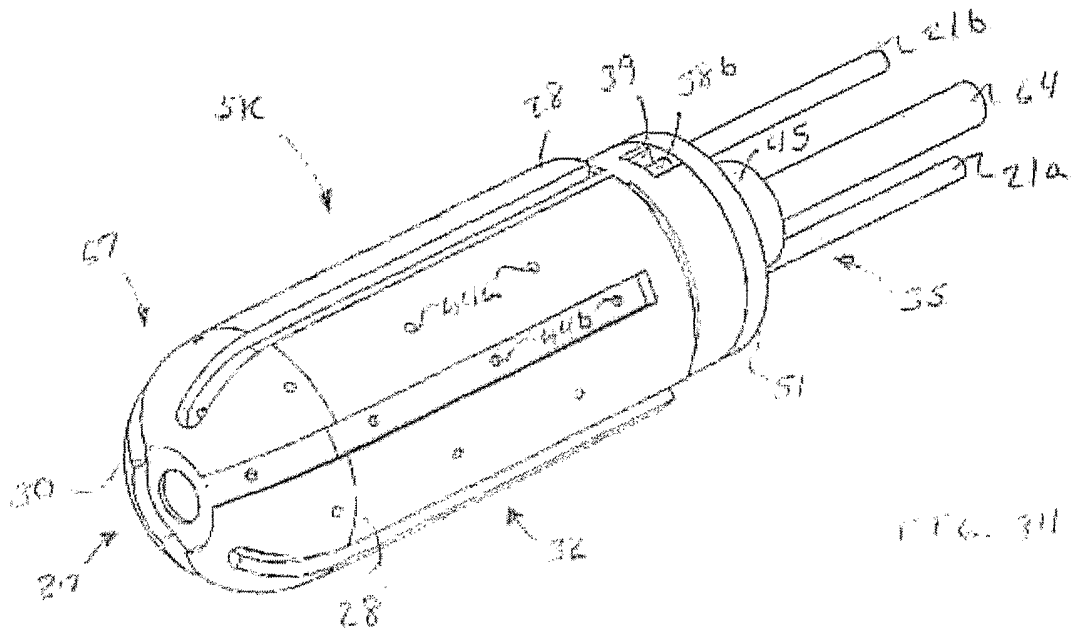

FIG 31





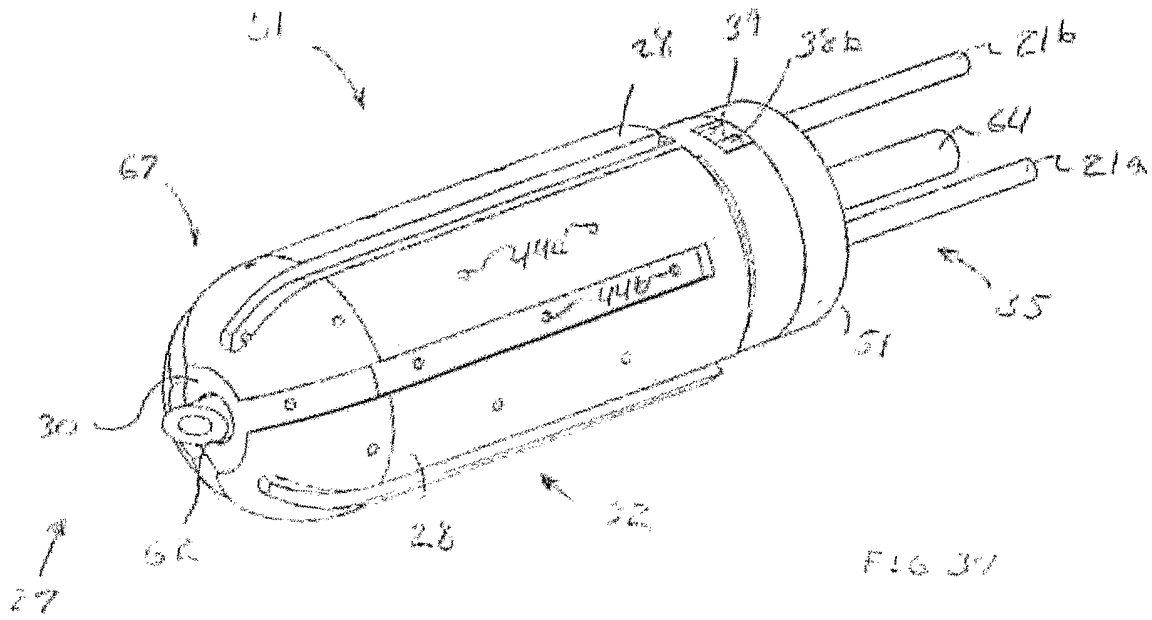

FIG. 37

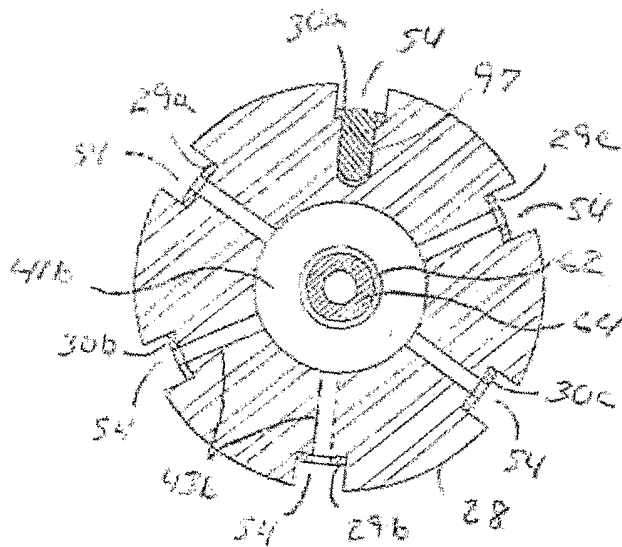

FIG. 38



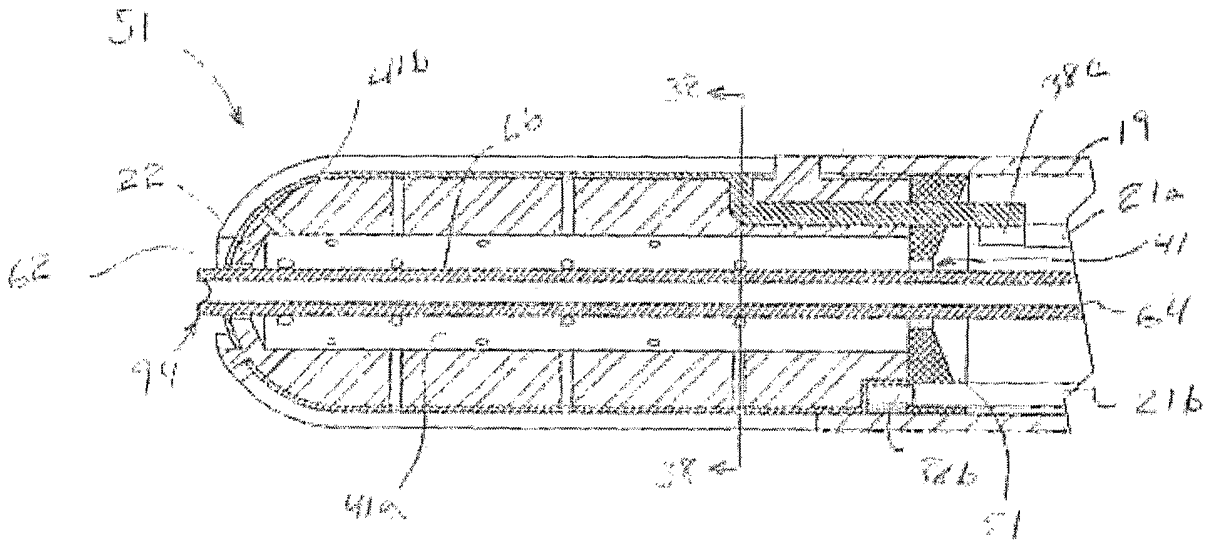

FIG 39

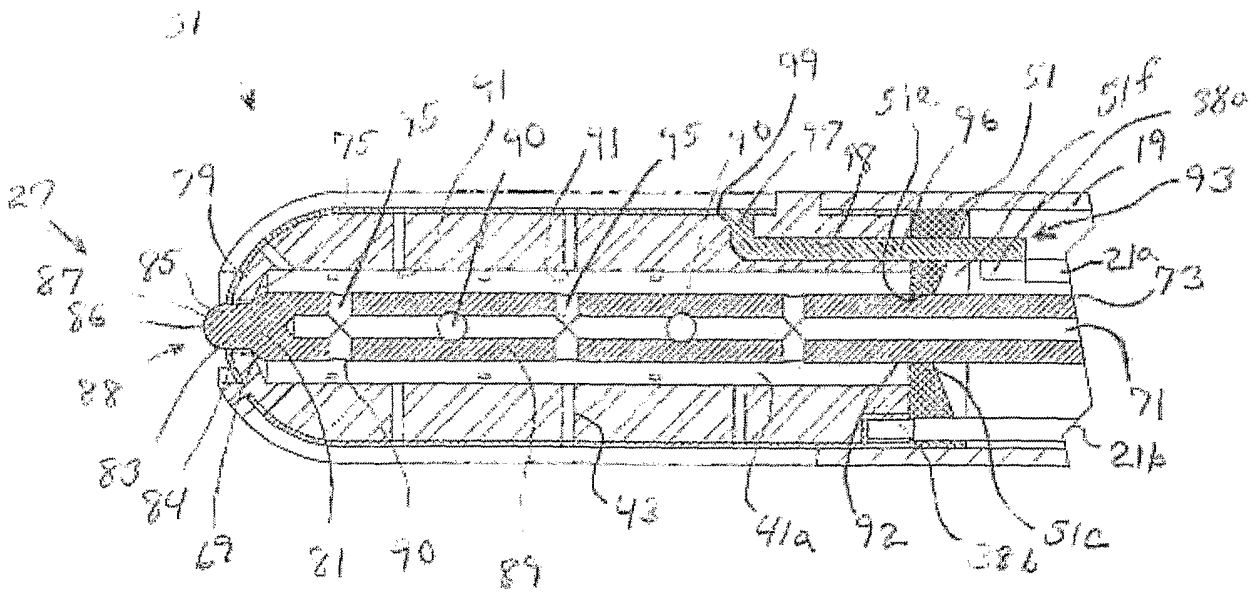
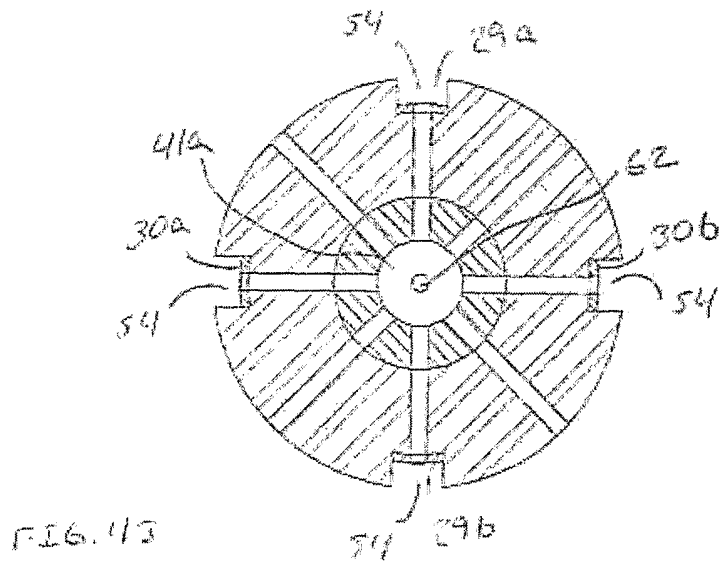
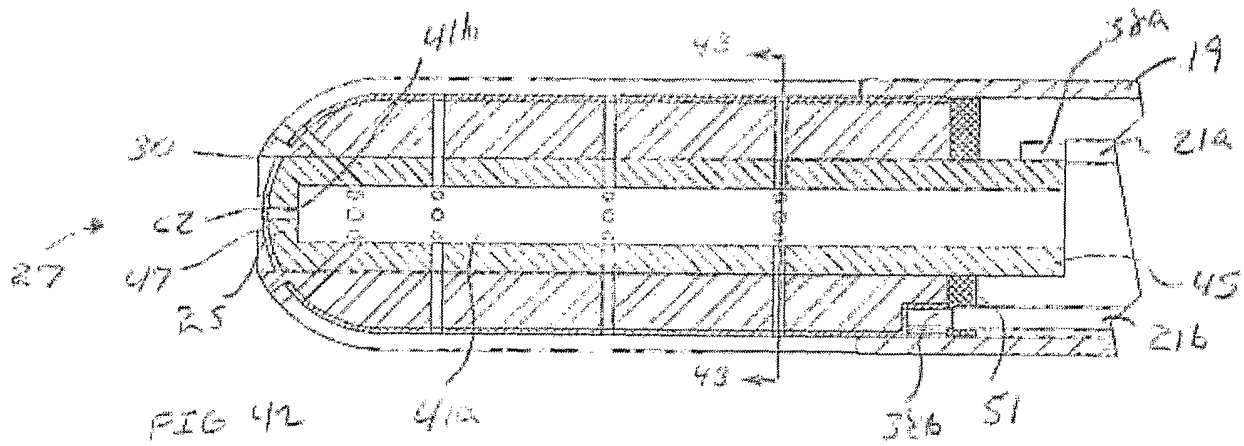
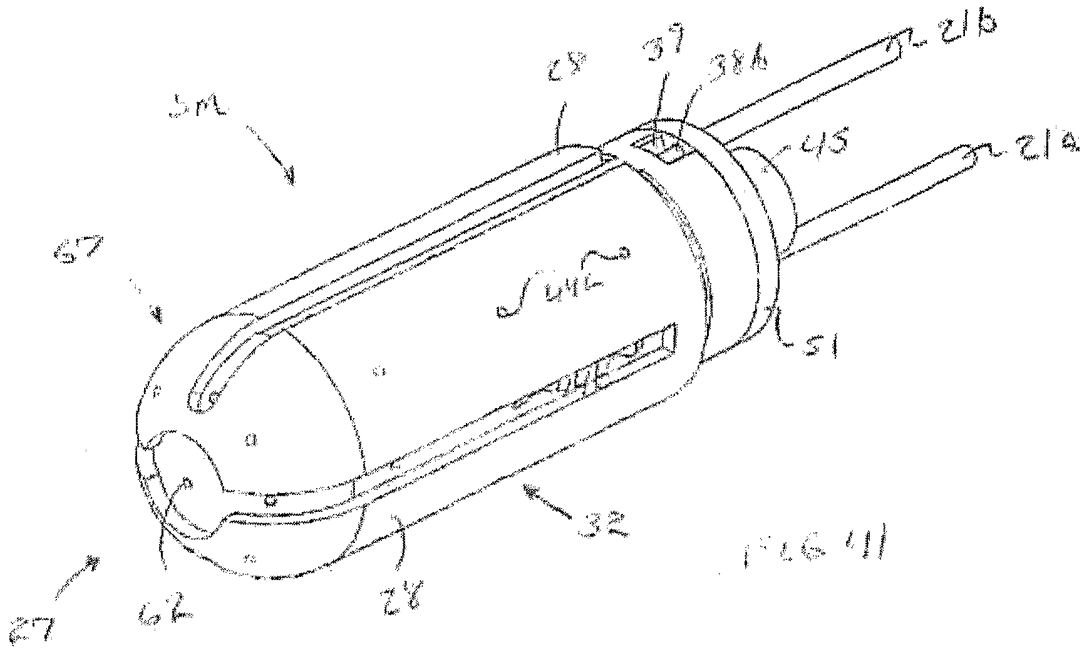
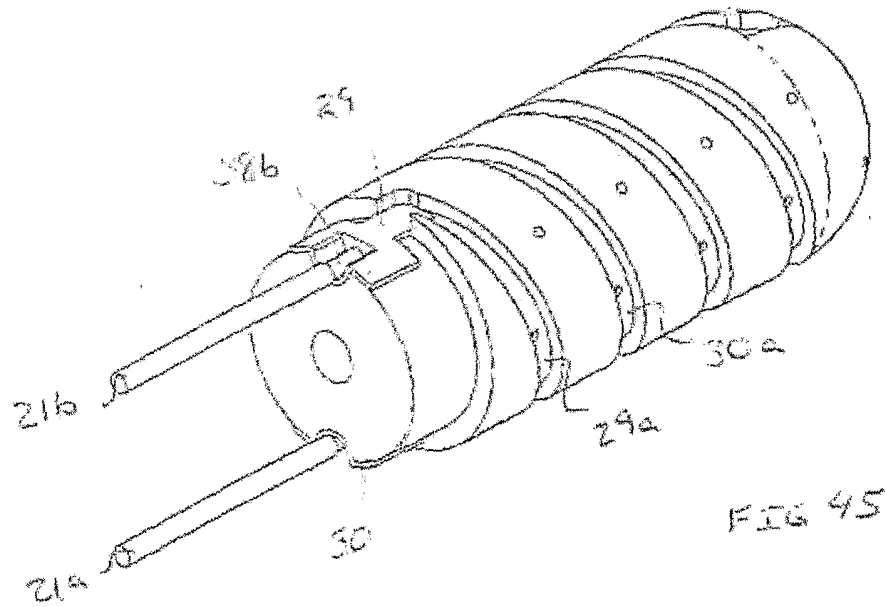
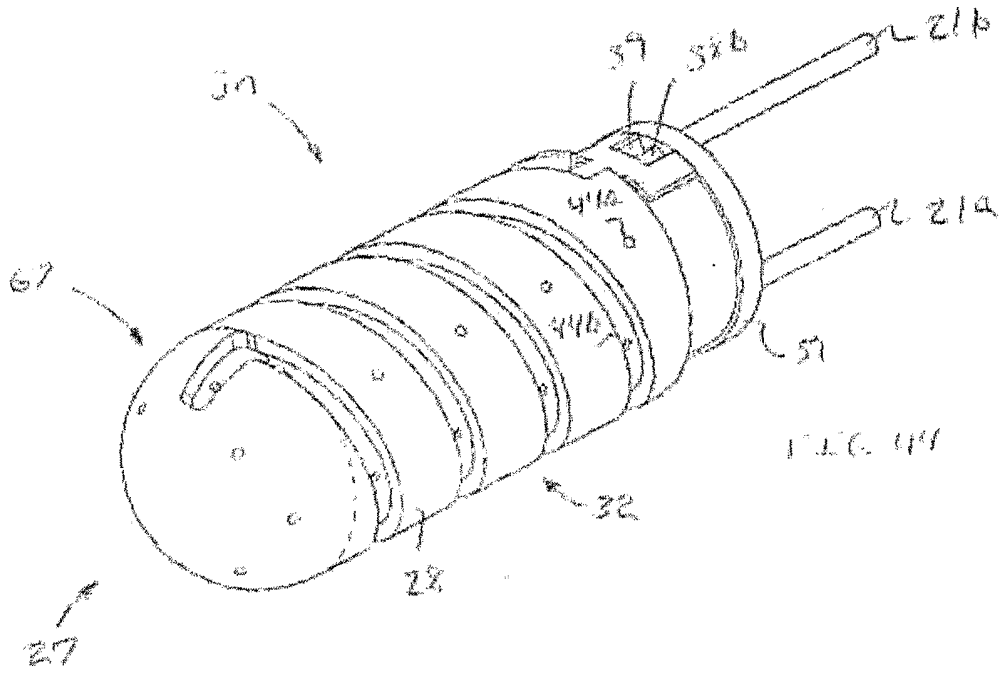
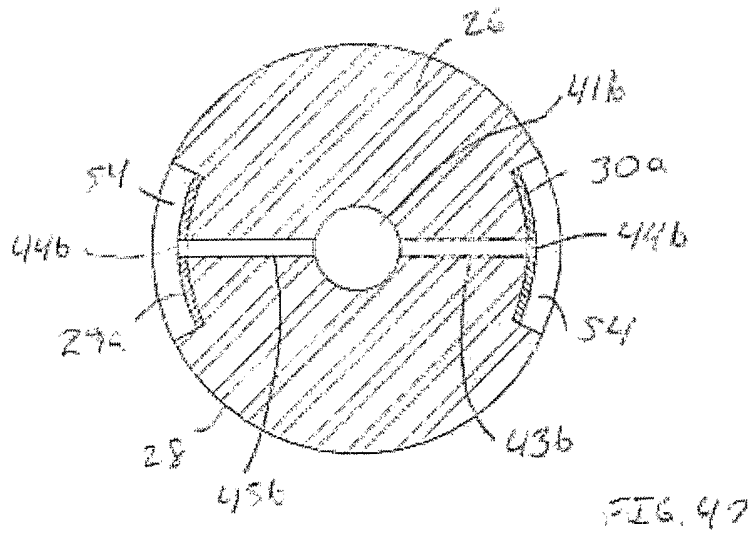
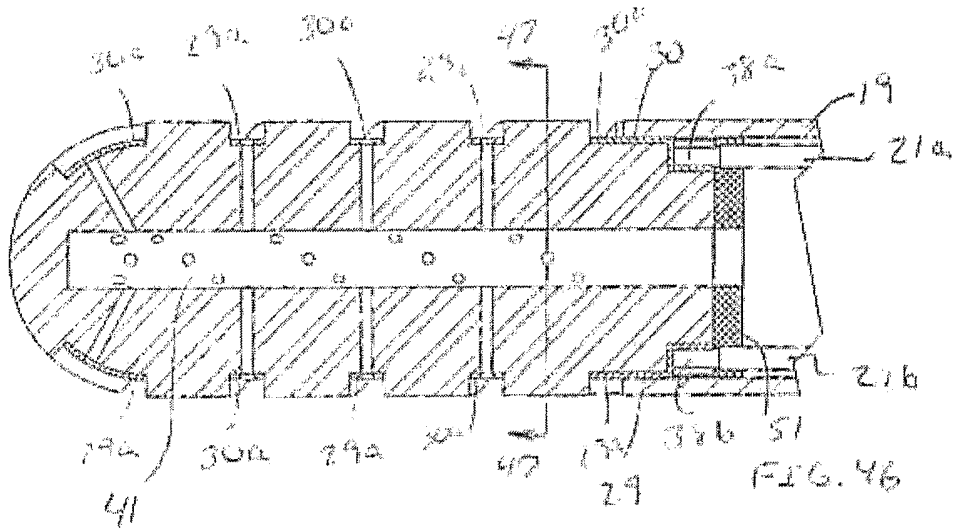
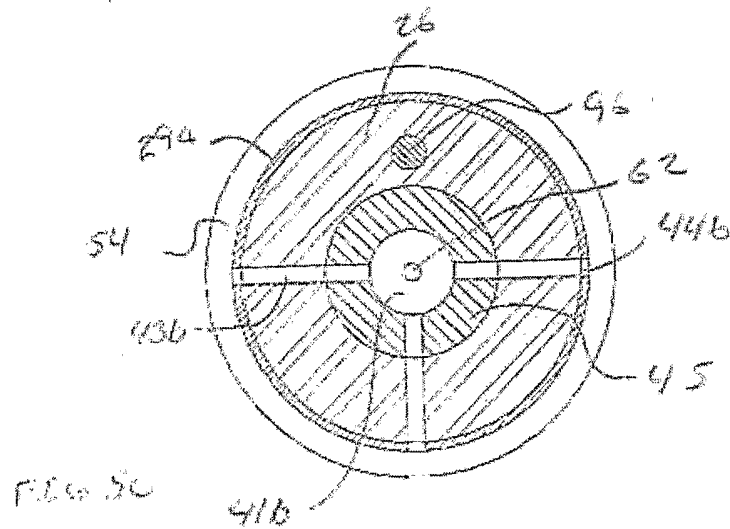
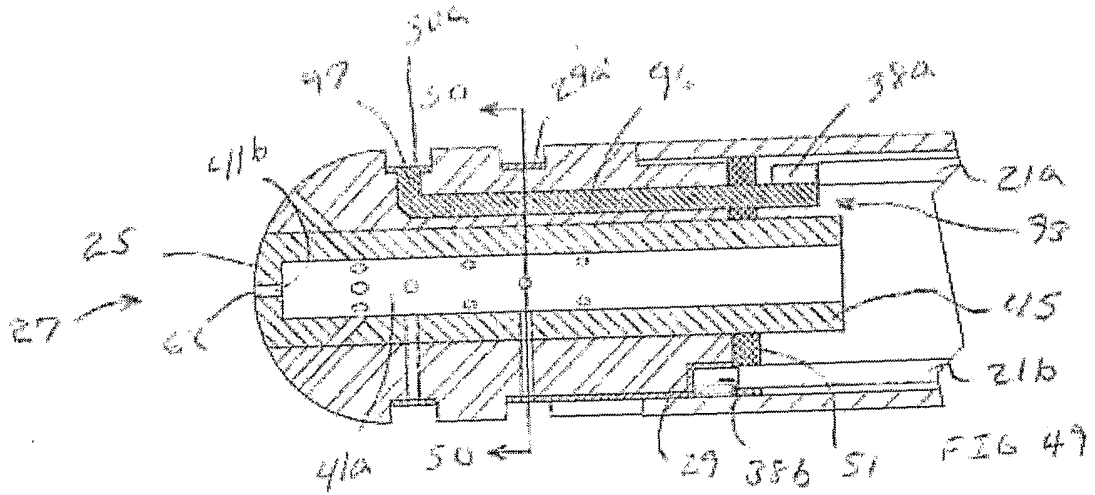
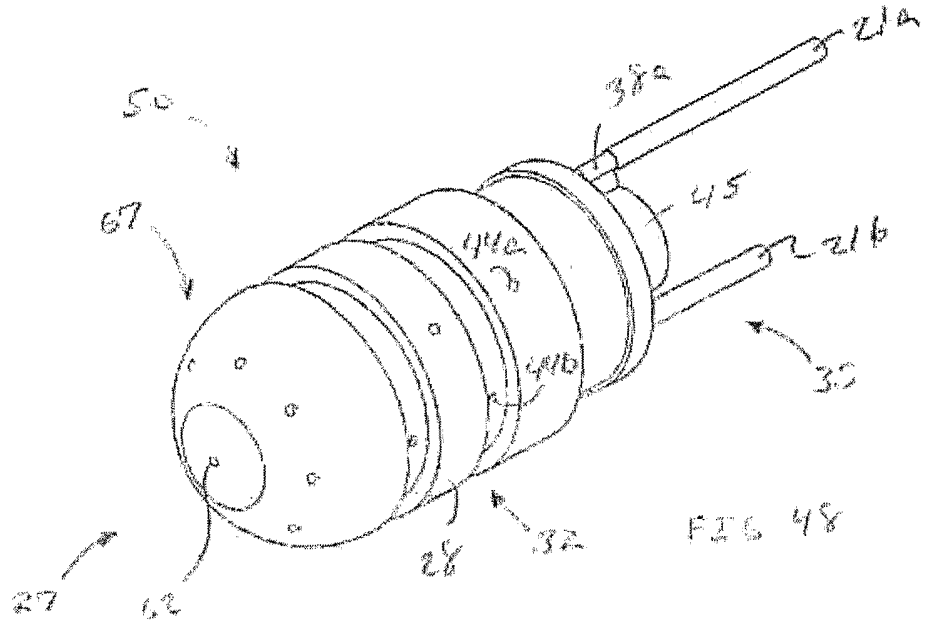

FIG 40









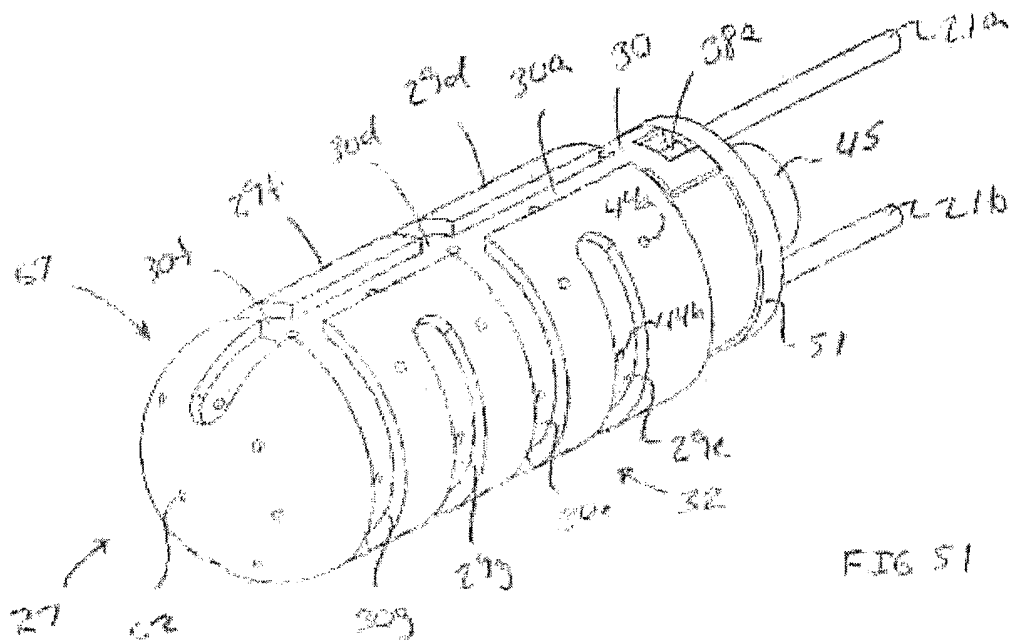

FIG 51

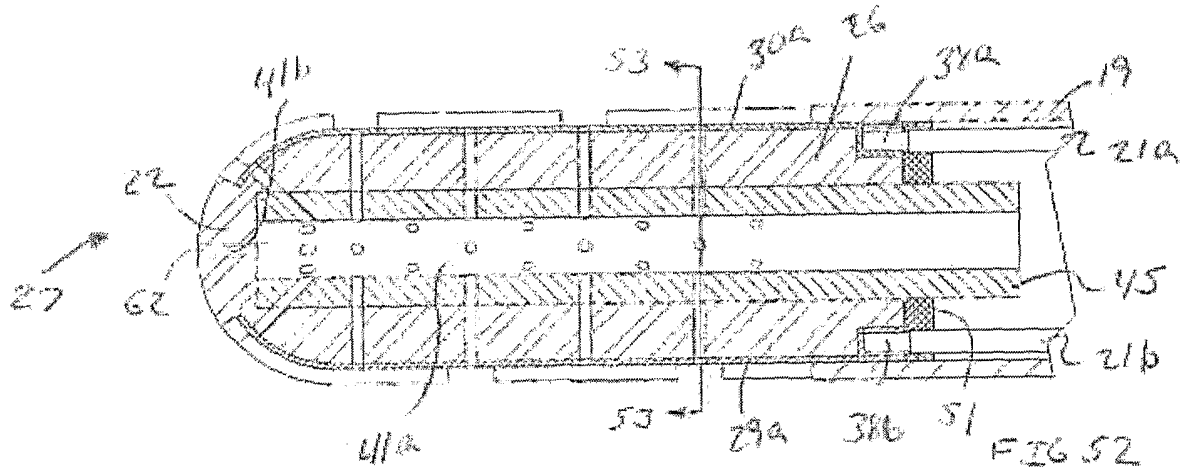

FIG 52

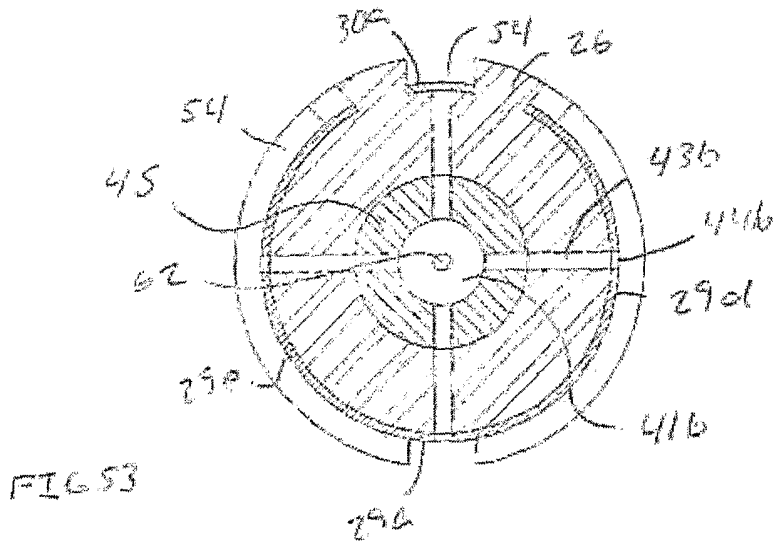

FIG 53

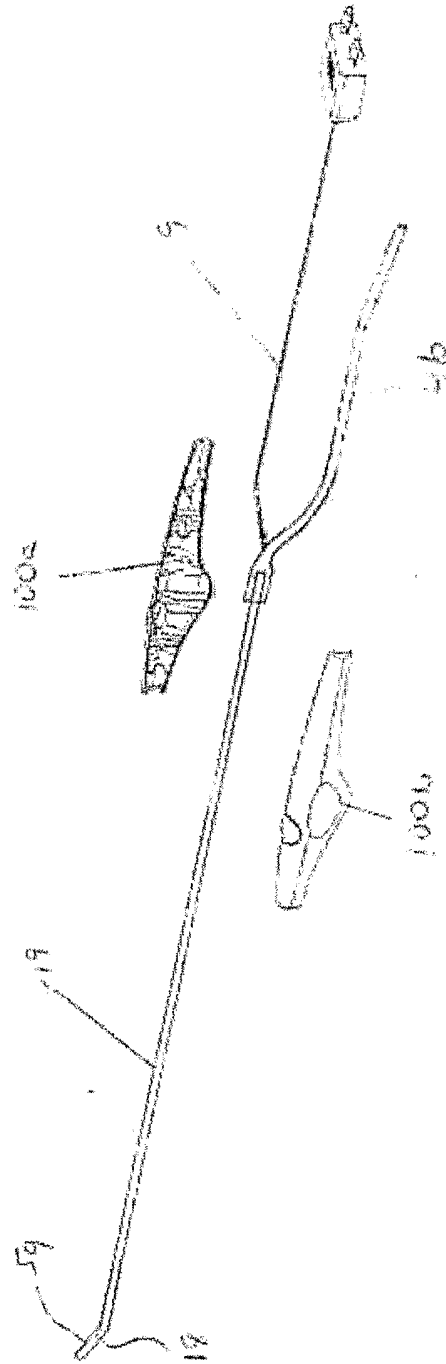

FIG. 54

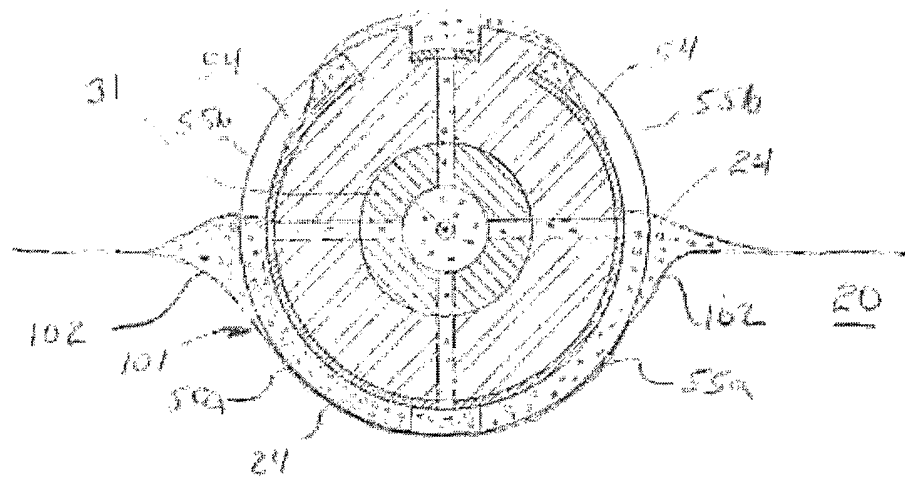

FIG. 55



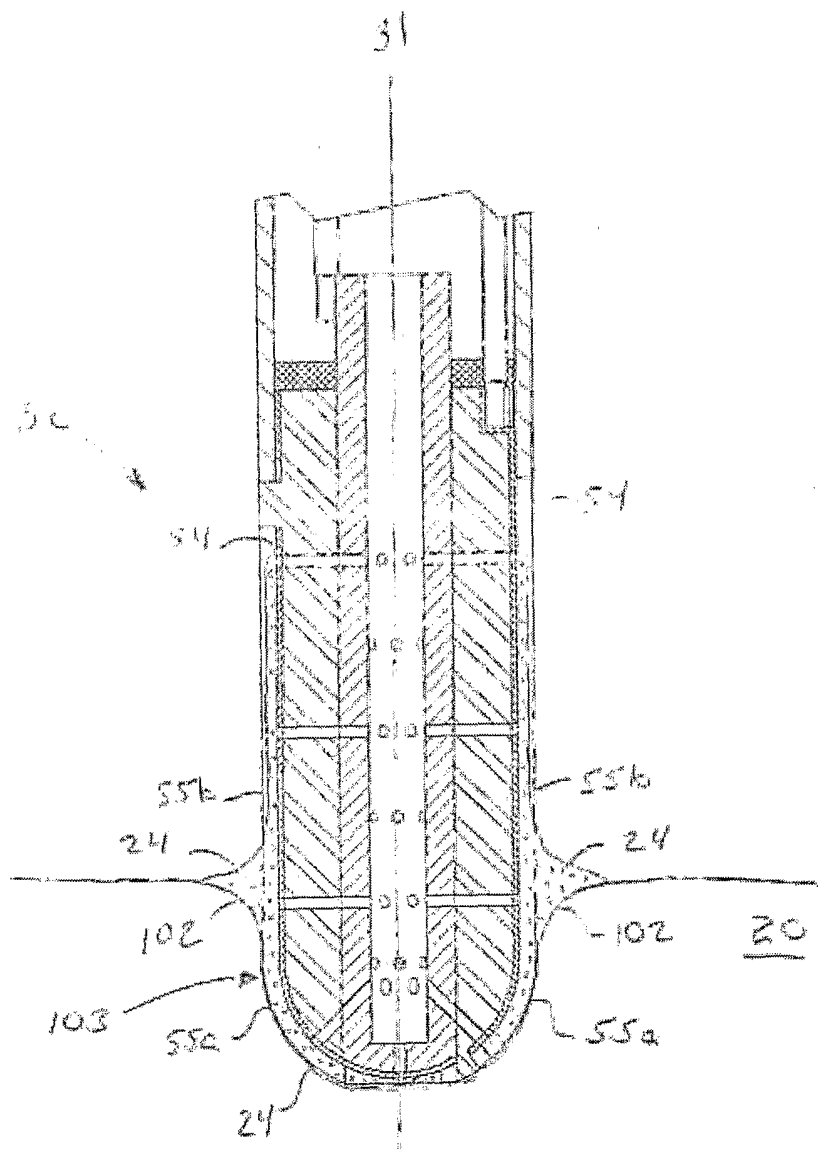

FIG. 56

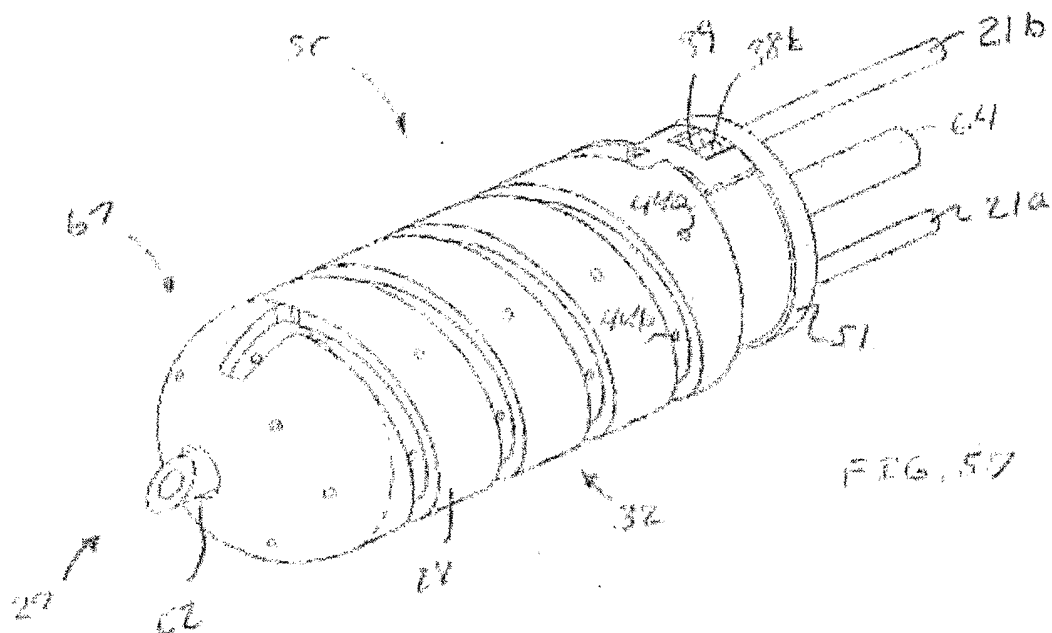

FIG. 57

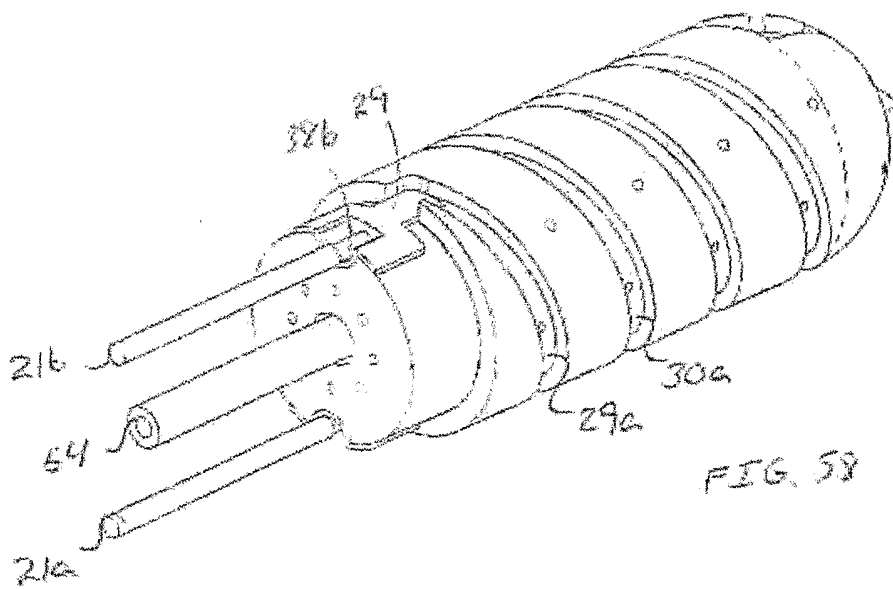

FIG. 58

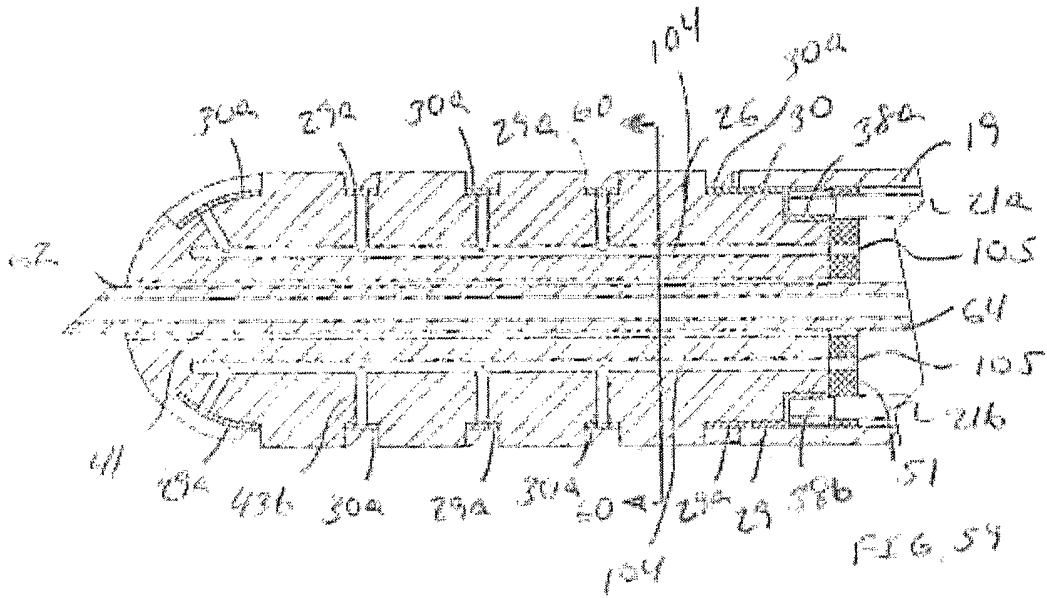

FIG. 59

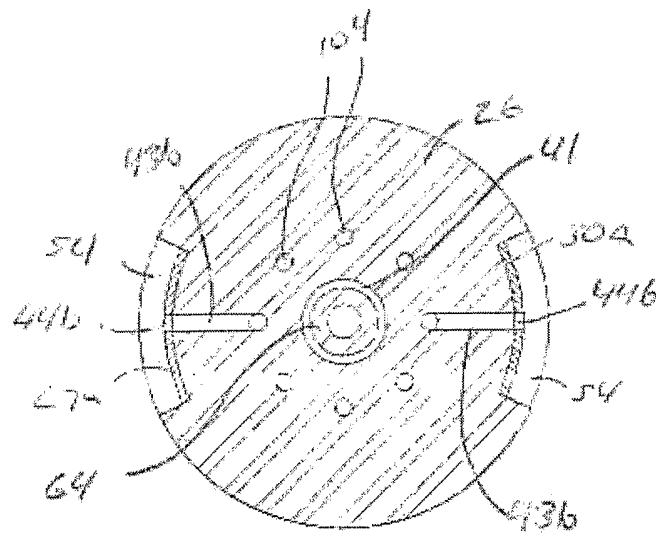

FIG. 60

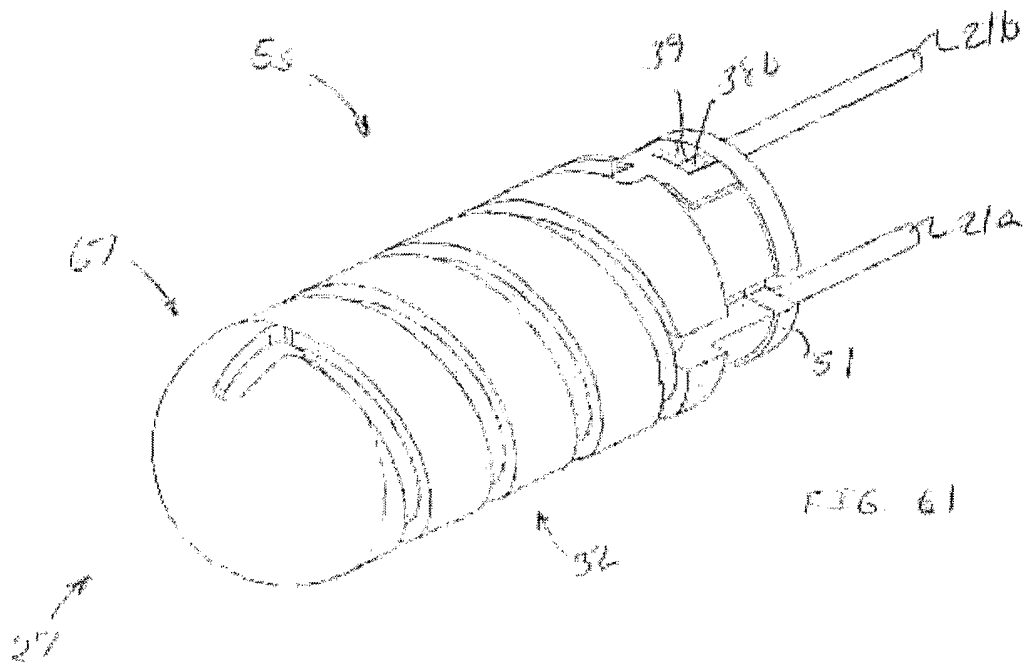

FIG. 61

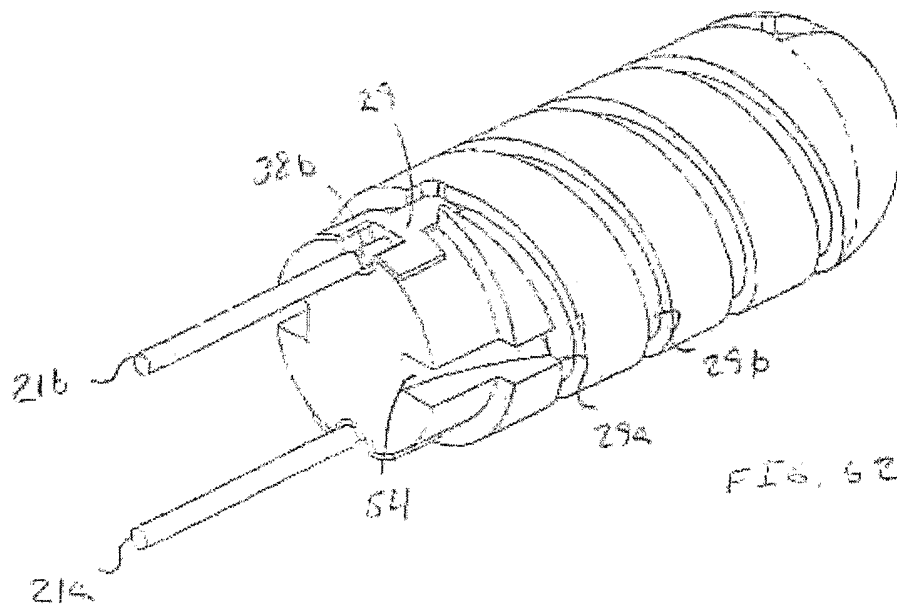
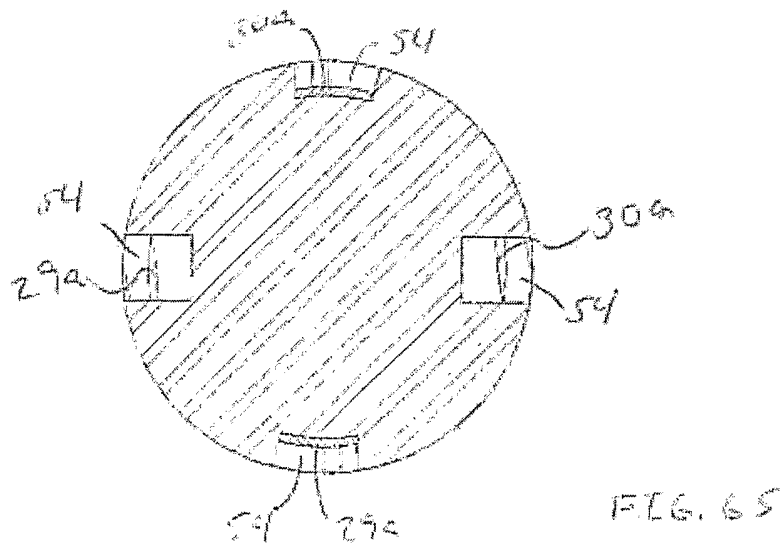
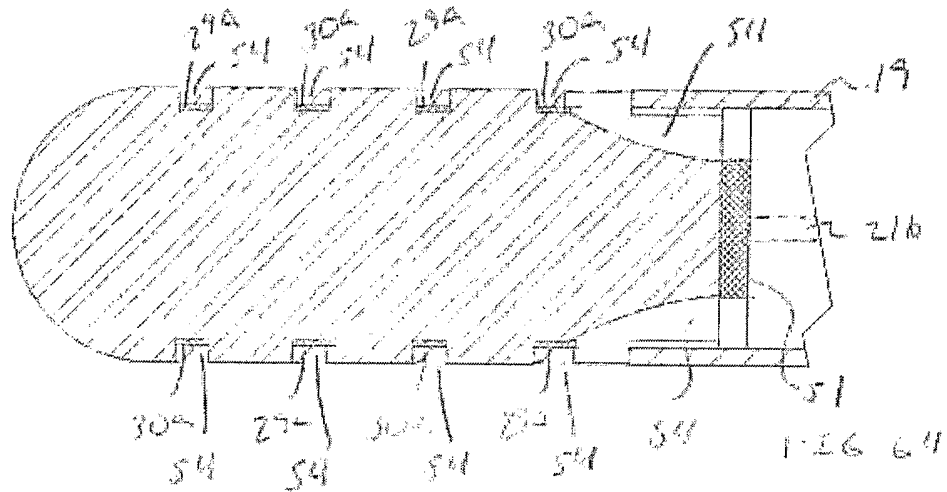
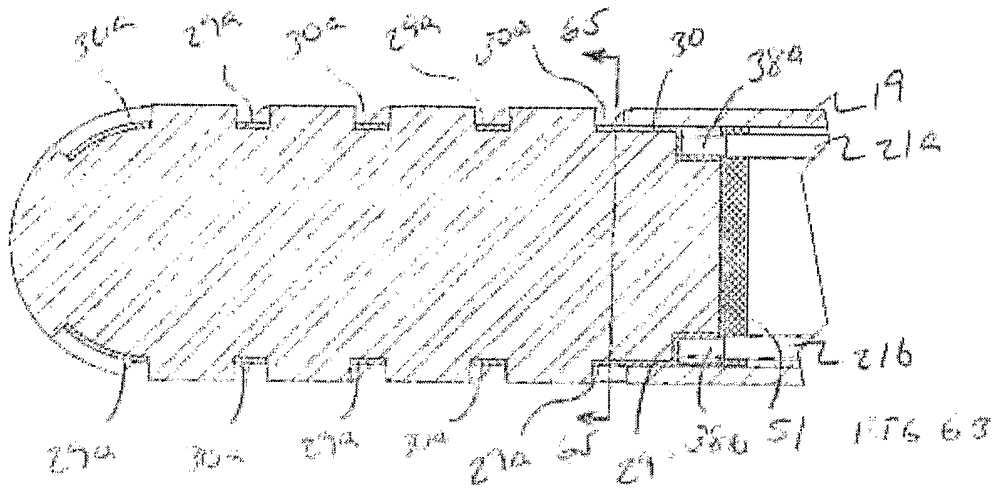

FIG. 62



INTERNATIONAL SEARCH REPORT

International application No.  
PCT/US02/39701

**A. CLASSIFICATION OF SUBJECT MATTER**  
IPC(7) :A61B 18/14  
US CL :606/50  
According to International Patent Classification (IPC) or to both national classification and IPC

**B. FIELDS SEARCHED**  
Minimum documentation searched (classification system followed by classification symbols)  
U.S. : 606/41, 46, 48, 50

Documentation searched other than minimum documentation to the extent that such documents are included in the fields searched

Electronic data base consulted during the international search (name of data base and, where practicable, search terms used)

**C. DOCUMENTS CONSIDERED TO BE RELEVANT**

Category*	Citation of document, with indication, where appropriate, of the relevant passages	Relevant to claim No.
Y	US 4,532,924 A (AUTH et al) 06 AUGUST 1985, se entire document.	1-20
Y	US 5,522,815 A (DURGIN, JR. et al) 04 JUNE 1996, see entire document.	1-20
Y	US 6,017,338 A (BRUCKER et al) 25 JANUARY 2000, see Figure 9.	1-20
A, E	US 2002/0193851 A (SILVERMAN et al) 19 DECEMBER 2002, see entire document.	1-20

Further documents are listed in the continuation of Box C.  See patent family annex.

* Special categories of cited documents:	"T" later document published after the international filing date or priority date and not in conflict with the application but cited to understand the principle or theory underlying the invention
"A" document defining the general state of the art which is not considered to be of particular relevance	"X" document of particular relevance: the claimed invention cannot be considered novel or cannot be considered to involve an inventive step when the document is taken alone
"E" earlier document published on or after the international filing date	"Y" document of particular relevance: the claimed invention cannot be considered to involve an inventive step when the document is combined with one or more other such documents, such combination being obvious to a person skilled in the art
"L" document which may throw doubts on priority claim(s) or which is cited to establish the publication date of another citation or other special reason (as specified)	"Z" document member of the same patent family
"O" document referring to an oral disclosure, use, exhibition or other means	
"P" document published prior to the international filing date but later than the priority date claimed	

Date of the actual completion of the international search 21 MARCH 2003	Date of mailing of the international search report 22 MAY 2003
--	---

Name and mailing address of the ISA/US Commissioner of Patents and Trademarks Box PCT Washington, D.C. 20231 Facsimile No. (703) 305-3230	Authorized officer LEE S. COHEN <i>Diane Smith</i> Telephone No. (703) 308-2998
---	---