



(22) Date de dépôt/Filing Date: 2004/06/30

(41) Mise à la disp. pub./Open to Public Insp.: 2005/12/30

(51) Cl.Int.<sup>7</sup>/Int.Cl.<sup>7</sup> E21B 33/12

(71) Demandeur/Applicant:  
CALFRAC WELL SERVICES LTD., CA

(72) Inventeur/Inventor:  
HAMILTON, BRENDON, CA

(74) Agent: MOFFAT & CO.

(54) Titre : OUTIL D'EXTRACTION

(54) Title: ISOLATION TOOL

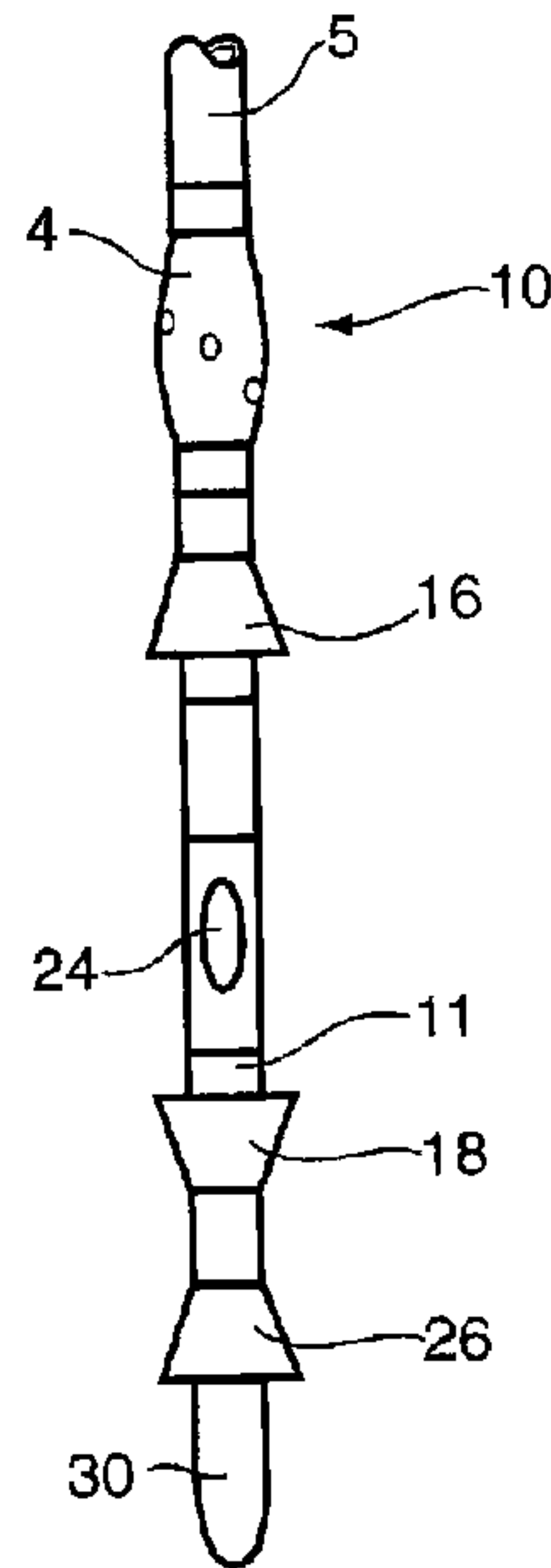

(57) Abrégé/Abstract:

A tool for use in the treatment of a formation penetrated by a well bore, the tool comprising a tubular core having at least one opening therein for the discharge of pressurized fluid from within the core first and second axially spaced apart sealing members disposed on the core for sealing between the core and the well bore, the at least one opening in the core being located between the first and second sealing members; and a third sealing member disposed downhole relative to the first and second sealing members for sealing between the tool and the well bore.

**ABSTRACT**

A tool for use in the treatment of a formation penetrated by a well bore, the tool comprising a tubular core having at least one opening therein for the discharge of pressurized fluid from within the core first and second axially spaced apart sealing members disposed on the core for sealing between the core and the well bore, the at least one opening in the core being located between the first and second sealing members; and a third sealing member disposed downhole relative to the first and second sealing members for sealing between the tool and the well bore.

## ISOLATION TOOL

### Field of the Invention

5 The present invention relates to the enhancement of an isolation tool usable when treating multiple zones in a well bore, and more particularly to an improved straddle packer.

### Background of the Invention

10 Sand fracturing through coiled tubing and through snubbing units has allowed the development of new trends in well stimulation. The ability to perforate multiple zones in a single well and then fracture each zone independently has increased access to more potential reserves.

15 The fracturing program starts at the lowest zone in the well bore. The term fracturing refers to the use of fluids and proppants utilized for injection at high pressure into oil or gas wells, to fracture the geological formations surrounding the well, and thereby increasing their productivity. This permits more efficient flow of hydrocarbons and accelerates access to the reserves.

The purpose of the fracturing fluid is two fold: first to transmit energy generated at surface down the well bore to hydraulically create a fracture within reservoir rock, and secondly, to transport a proppant agent (usually sand) from surface to the reservoir to ensure conductivity generated by the fracture is preserved.

20 A hydraulic fracturing treatment typically consists of three main stages. Initially a "Pad" stage is pumped to initiate the fracture and create width for the stages to follow. The fluid pumped through this initial stage consists of the fracturing fluid without proppants. After a sufficient volume of Pad has been pumped, proppant is added to the fracturing fluid to form the "Slurry" stage. Concentrations of the proppant (sand, resin-coated sand, or ceramics) typically are kept low at the beginning and slowly ramped up  
25 to maximum values, which vary as a function of depth, fracturing pressures and reservoir type. An optimization process utilizing numerical and analytical simulation models can be used to determine the amount of proppant that is pumped, as is known in the art.

Once the appropriate volume of proppant has been mixed by the blender and pumped down the well bore, a "Flush" stage, consisting of more fracturing fluid, is used to displace the slurry stage to the perforations.

5 Treatment design is based on several parameters that include, but are not limited to, reservoir permeability, pressure, depth, temperature and reservoir fluid type. Fracture  
fluid viscosity, down-hole injection rates, proppant size and type, proppant volume and  
concentrations are all important aspects of the final stimulation program. As is well  
known in the art, engineering modelling tools, together with previous field experience  
gained in each area, are used in a combined approach to formulate the best possible  
10 stimulation design for the reservoir.

A desirable feature in a fracturing fluid is variable viscosity. That is, fluids will  
frequently contain additives that can be selectively added, chemically or physically, to  
increase or decrease the viscosity of the fluid. The reason a high viscosity is desired is  
for the transport of proppant down the well bore and into the fracture, such as sand  
15 granules into a fractured formation to prevent the fracture from completely closing in the  
formation. The proppant ensures that the conductivity of the fracture is maintained.  
Afterwards, it is desirable to lower the viscosity of the fluid, so that it will flow out of the  
fracture into the well bore and to surface, allowing the flow of hydrocarbons to begin or  
resume.

20 Prior to commencement of the fracturing treatment, the straddle packer is placed  
across the lowest perforated interval and that zone is then fractured. Generally, a  
straddle packer comprises a pair of vertically spaced apart seals mounted on a tubular  
barrel that has an orifice to allow the fracturing fluid pumped through the barrel's interior  
to escape into the annulus between the barrel and the well casing. The pressure of the  
25 fluid expands the seals into sealing contact with the casing's inner wall so that the fluid  
then diverts itself through the perforations in the casing into the targeted formation. The  
seals are set sufficiently far apart to straddle the width of the zone to be fractured.

After treatment of the lowest zone, the tool is moved up the casing to the next  
perforated interval and this zone is then fractured. This operation is repeated for all the  
30 perforated intervals.

Particularly if the fracturing fluids have been energized, that is, co-mingled with a pressurized gas such as CO<sub>2</sub> or N<sub>2</sub>, it becomes extremely important to complete all the zones quickly and then allow the well to begin flowing back from the co-mingled zones for recovery of injected fluids.

5           Current isolation tools work effectively at isolating the zone and fracturing once  
down the well bore. However, when fracturing multiple zones in the well bore, and when  
the pressure of a previously treated lower zone exceeds the resistance of the tool's lower  
sealing member, fluid with sand will flow past the lower sealing member, collapsing it,  
and possibly even flowing into the tool body. This can prevent the tool from moving up  
10 the well bore, seating at the next interval or sealing the next set of perforations. These  
consequences can all create serious job problems and/or failures.

### Summary of the Invention

In view of the foregoing, there is a need for a device of simple design allowing  
multiple zones along the well bore to be securely sealed and isolated from outside sand  
15 and fluids.

In a preferred embodiment of the present invention, the present tool is modified  
by adding a third sealing member below the lower sealing member. This third seal can  
be of similar material to the upper and lower seals and can be manufactured from  
rubber, urethane or any other similar material as will be apparent to those skilled in the  
20 art. The purpose of the third seal is to prevent fluid and sand from below the tool from  
entering the zone being isolated by the straddle packer.

According to the present invention then, there is provided a tool for use in the  
treatment of a formation penetrated by a well bore, the tool comprising a tubular core  
having at least one opening therein for the discharge of pressurized fluid from within said  
core; first and second axially spaced apart sealing members disposed on said core for  
25 sealing between said core and said well bore, said at least one opening in said core  
being located between said first and second sealing members; and a third sealing  
member disposed downhole relative to said first and second sealing members for  
sealing between said tool and said well bore.

According to a further aspect of the present invention, there is also provided a straddle packer for use to isolate a segment of a well bore penetrating a formation to be treated with a pressurized fluid, comprising a central tubular member having at least one orifice formed therein for the discharge of said pressurized fluid; a first seal member  
5 located above said orifice for fluid sealing between said central member and said well bore; a second seal located below said orifice for fluid sealing between said central member and said well bore; and a third seal located below said second seal for fluid sealing between said tubular member and said well bore, said third seal acting to isolate said second seal from pressure in said well bore below said straddle packer.

10 According to yet another aspect of the present invention, there is also provided a method for sequentially isolating segments of a well bore penetrating formations to be treated by a pressurized fluid, comprising the steps of isolating a first segment of said well bore using a tool comprising a tubular core having at least one opening therein for the discharge of pressurized fluid from within said core; first and second axially spaced  
15 apart sealing members disposed on said core for sealing between said core and said well bore, said at least one opening in said core being located between said first and second sealing members; and a third sealing member disposed downhole relative to said first and second sealing members for sealing between said tool and said well bore; injecting pressurized fluid through said tool and said opening in the core thereof, said  
20 fluid entering into the formation for the treatment thereof through perforations in said well bore, said first and second sealing members containing said pressurized fluid against escape; moving said tool upwardly in said well bore to isolate the next segment of said well bore and again injecting said pressurized fluid into a formation adjacent said next segment of said well bore; and using said third sealing member to isolate said first and  
25 second sealing members from pressure acting from below said tool.

According to still another aspect of the present invention, there is also provided a method for isolating a segment of a well bore penetrating a formation to be treated by a pressurized fluid, comprising the steps of isolating said segment of said well bore using a tool comprising a tubular core having at least one opening therein for the discharge of  
30 pressurized fluid from within said core; first and second axially spaced apart sealing

members disposed on said core for sealing between said core and said well bore, said at least one opening in said core being located between said first and second sealing members; and a third sealing member disposed downhole relative to said first and second sealing members for sealing between said tool and said well bore; injecting  
5 pressurized fluid through said tool and said opening in the core thereof, said fluid entering into the formation for the treatment thereof through perforations in said well bore, said first and second sealing members containing said pressurized fluid against escape; and using said third sealing member to isolate said first and second sealing members from pressure acting from below said tool.

### 10 Brief Description of the Drawings

Preferred embodiments of the present invention will now be described in greater detail and will be better understood when read in conjunction with the following drawings in which:

15 Figure 1 is a side elevational view of a known straddle packer having a pair of upper and lower sealing members;

Figure 2 is a side elevational view of an isolation tool modified in accordance with one aspect of the present invention;

Figure 3 is a side elevational view of the tool of Figure 2 deployed in the well bore;

20 Figure 4 is a side elevational view of a sealing member forming part of the tool of Figure 2 when not exposed to pressure; and

Figure 5 is a side elevational view of the sealing member of Figure 4 exposed to pressure.

### Detailed Description of the Preferred Embodiments

25 With reference to Figure 1, a conventional isolation tool in the nature of a straddle packer 10 is shown. The tool is suspended down-hole by a length of coiled tubing 5 or at the end of snubbing unit (not shown) and is connected to the tubing by means of a coiled tubing connector and a disconnect shown collectively at 4. Connectors and disconnects are well known in the art and will not be described here in detail. Coiled

tubing is not internally threaded in the manner of jointed pipe and hence specialized connectors are needed to join the tubing to down-hole tools and assemblies. Disconnects are operable from the surface to uncouple the tubing from the tool in the event the tool becomes stuck in the well bore. Should that happen, the tubing, which is  
5 of limited tensile strength, is removed and either a fishing tool at the end of stronger tubular stock is lowered into the well to grapple the stuck device, or a type of ram is used to push the tool to the well bottom. It will be understood that although the present tool is advantageously used with coiled tubing, it can also be used with conventional threaded pipe. As well, although the tool's primary use will likely be in respect of  
10 fracturing operations, it can be used in any instance in which fluids are to be injected for other forms of treatments such as acidizing.

Isolation tool 10 itself consists of a tubular core 11 connectable at its upper end to coiled tubing 5 to be in fluid communication therewith for the flow of fracturing fluid and proppant through the tubing, into the core and then into the annulus 13 between  
15 core 11 and well casing 14 through an orifice 24. For purposes of this description, core 11 comprises at least the portion of the tool beneath the coiled tubing 5 that includes orifice 24 but more broadly can also include the entire length of the tool beneath disconnect 4 which might variably include various subs, housings, cross-overs, extensions and even bullnose 30 located at the tool's lowermost end which facilitates  
20 insertion into the well bore. As used herein, the term "tubular" means that fluid communication exists at least between coiled tubing 5 and orifice 24. The remaining portions of the core can be either tubular or solid as the user elects or prefers.

Sealing between core 11 and casing 14 is provided by a pair of vertically spaced apart seals including an upper seal 16 and a lower seal 18. Numerous types of seals  
25 are known in the art but perhaps most commonly, the seals are frustoconically shaped cups as shown in the drawings.

The cups are mounted onto core 11 in a known fashion so that their inner flared ends face one another. Prior to the introduction of pressurized fluid, the seals are sized to only partially occupy annulus 13 as shown in Figure 4. When fracturing fluid enters  
30 the annulus, the cups react by expanding into sealing contact with the casing walls as

shown most clearly in Figure 5. Fluid flow is then diverted through perforations 19 in the casing wall and enters formation 20b to induce fracturing.

The distance between seals 16 and 18 can be selected by choosing the length of core 11 or by segmenting the core using as many or as few tubular subs 8 as required  
5 for the desired degree of separation.

After formation 20a has been treated, tool 10 is then moved into position opposite the next set of perforations at formation 20b. Formation 20a, having already been treated, is now releasing formation pressure, fracturing fluid (often energized) and sand into the casing, the collective pressure of which now acts in the direction of arrows 22  
10 against lower seal 18. This pressure can exceed the pressure between seals 16 and 18, causing seal 18 to fail and allowing down-hole fluid and sand to bypass the cup with potentially serious consequences.

To prevent this, the applicant has found a simple yet entirely effective solution as shown most clearly in Figures 2 and 3 wherein like numerals have been used to identify  
15 like elements.

As will be seen, tool 10 has been modified to include a third seal 26 located beneath lower seal 18. In a preferred embodiment constructed by the applicant, seal 26 is again a frustoconical cup with its wider end oriented down-hole so that trapped pressure from a previously heated zone acting in the direction of arrows 22 causes the  
20 cup to seal against the casing. This effectively prevents fluid and sand from reaching the upper part of the tool including lower seal 18.

The addition of this third seal allows for a significant improvement in tool performance when stimulating multiple zones in the least amount of time, and that allows the well to flow back as quickly as possible with fewer possible complications.

The above-described embodiments of the present invention are meant to be illustrative of preferred embodiments of the present invention and are not intended to limit the scope of the present invention. Various modifications, which would be readily apparent to one skilled in the art, are intended to be within the scope of the present invention. The only limitations to the scope of the present invention are set out in the  
25  
30 following appended claims.

**THE EMBODIMENTS OF THE INVENTION IN WHICH AN EXCLUSIVE PROPERTY OR PRIVILEGE IS CLAIMED ARE DEFINED AS FOLLOWS:**

1. A tool for use in the treatment of a formation penetrated by a well bore, the tool comprising:
  - a tubular core having at least one opening therein for the discharge of pressurized fluid from within said core;
  - first and second axially spaced apart sealing members disposed on said core for sealing between said core and said well bore, said at least one opening in said core being located between said first and second sealing members; and
  - a third sealing member disposed downhole relative to said first and second sealing members for sealing between said tool and said well bore.
2. The tool of claim 1 wherein said first, second and third sealing members are all actuatable into sealing contact with said well bore in response to fluid pressure acting thereon.
3. The tool of claims 1 or 2 wherein said third sealing member isolates at least the lowermost of said first and second sealing members from pressure acting from below said third sealing member.
4. The tool of claims 1, 2 or 3 wherein the axial distance between said first and second sealing members is selected to straddle a predetermined length of said well bore.
5. The tool of any of claims 1 to 4 wherein said tool is connected to the downhole end of tubing extending down the well bore from the surface for fluid communication between said tubing and said at least one opening in said core for the delivery of pressurized fluid through said tubing, into said core and through said opening in said core.

6. The tool of any of claims 1 to 5 wherein the pressure of said pressurized fluid acts against said first and second sealing members to bias them into sealing contact with said well bore.
7. The tool of any of claims 1 to 6 wherein said pressurized fluid is fracturing fluid.
8. The tool of claim 7 wherein said fracturing fluid includes proppants entrained therein.
9. The tool of any of claims 1 to 8 wherein said tool is a straddle packer.
10. A straddle packer for use to isolate a segment of a well bore penetrating a formation to be treated with a pressurized fluid, comprising:
  - a central tubular member having at least one orifice formed therein for the discharge of said pressurized fluid;
  - a first seal member located above said orifice for fluid sealing between said central member and said well bore;
  - a second seal located below said orifice for fluid sealing between said central member and said well bore; and
  - a third seal located below said second seal for fluid sealing between said tubular member and said well bore, said third seal acting to isolate said second seal from pressure in said well bore below said straddle packer.
11. The straddle packer of claim 10 wherein said first, second and third seal members are resiliently deformable into sealing contact with said well bore in response to fluid pressure acting thereon.
12. The straddle packer of claims 11 or 12 wherein said tubular member can be elongated to increase the spacing between said first and second seal members.

13. The straddle packer of claim 12 wherein said tubular member can be elongated by the addition of tubular extensions disposed in said tubular member between said first and second seal members.

14. A method for sequentially isolating segments of a well bore penetrating formations to be treated by a pressurized fluid, comprising the steps of:

isolating a first segment of said well bore using a tool comprising a tubular core having at least one opening therein for the discharge of pressurized fluid from within said core; first and second axially spaced apart sealing members disposed on said core for sealing between said core and said well bore, said at least one opening in said core being located between said first and second sealing members; and a third sealing member disposed downhole relative to said first and second sealing members for sealing between said tool and said well bore;

injecting pressurized fluid through said tool and said opening in the core thereof, said fluid entering into the formation for the treatment thereof through perforations in said well bore, said first and second sealing members containing said pressurized fluid against escape;

moving said tool upwardly in said well bore to isolate the next segment of said well bore and again injecting said pressurized fluid into a formation adjacent said next segment of said well bore; and

using said third sealing member to isolate said first and second sealing members from pressure acting from below said tool.

15. The method of claim 14 wherein said pressurized fluid is a fracturing fluid for hydraulically fracturing said formation.

16. A method for isolating a segment of a well bore penetrating a formation to be treated by a pressurized fluid, comprising the steps of:

isolating said segment of said well bore using a tool comprising a tubular core having at least one opening therein for the discharge of pressurized fluid from within said

core; first and second axially spaced apart sealing members disposed on said core for sealing between said core and said well bore, said at least one opening in said core being located between said first and second sealing members; and a third sealing member disposed downhole relative to said first and second sealing members for sealing between said tool and said well bore;

injecting pressurized fluid through said tool and said opening in the core thereof, said fluid entering into the formation for the treatment thereof through perforations in said well bore, said first and second sealing members containing said pressurized fluid against escape; and

using said third sealing member to isolate said first and second sealing members from pressure acting from below said tool.

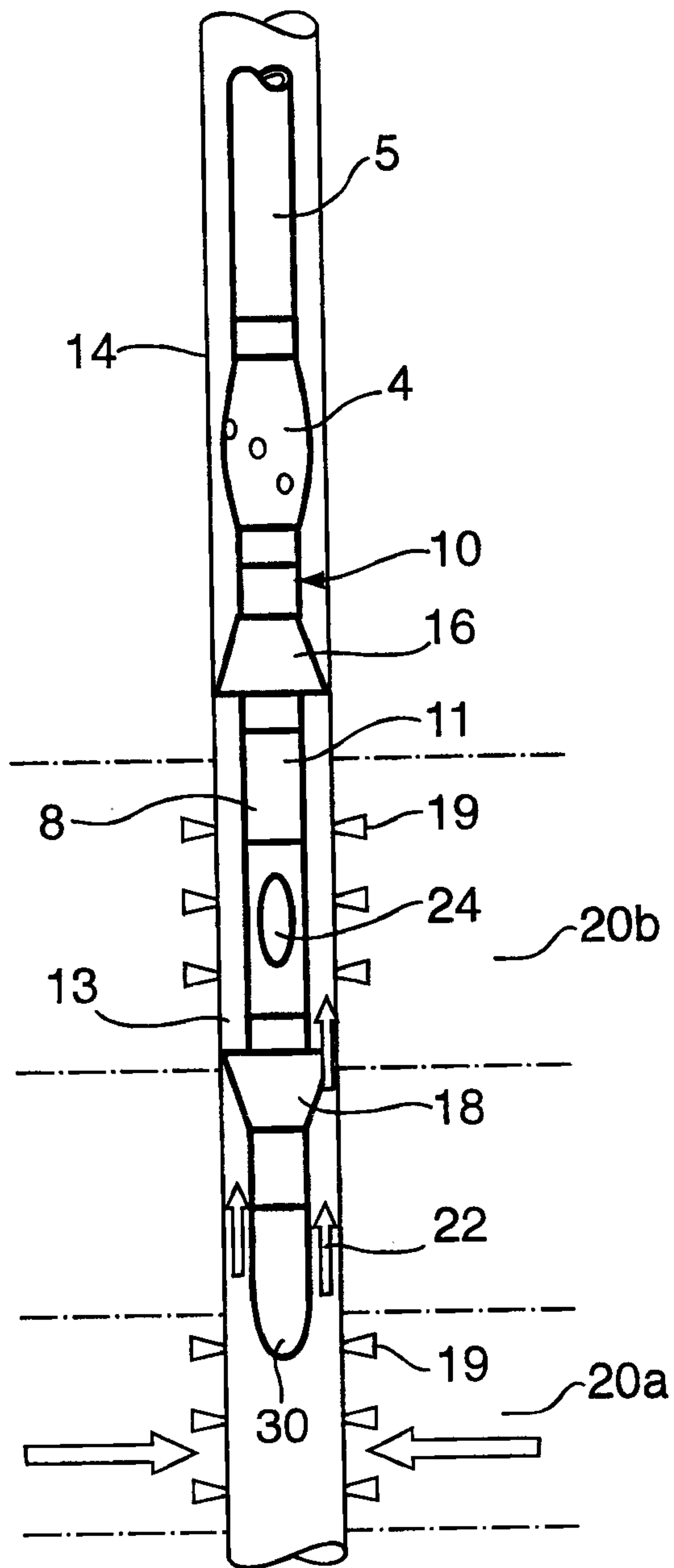

**FIG. 1**  
**PRIOR ART**

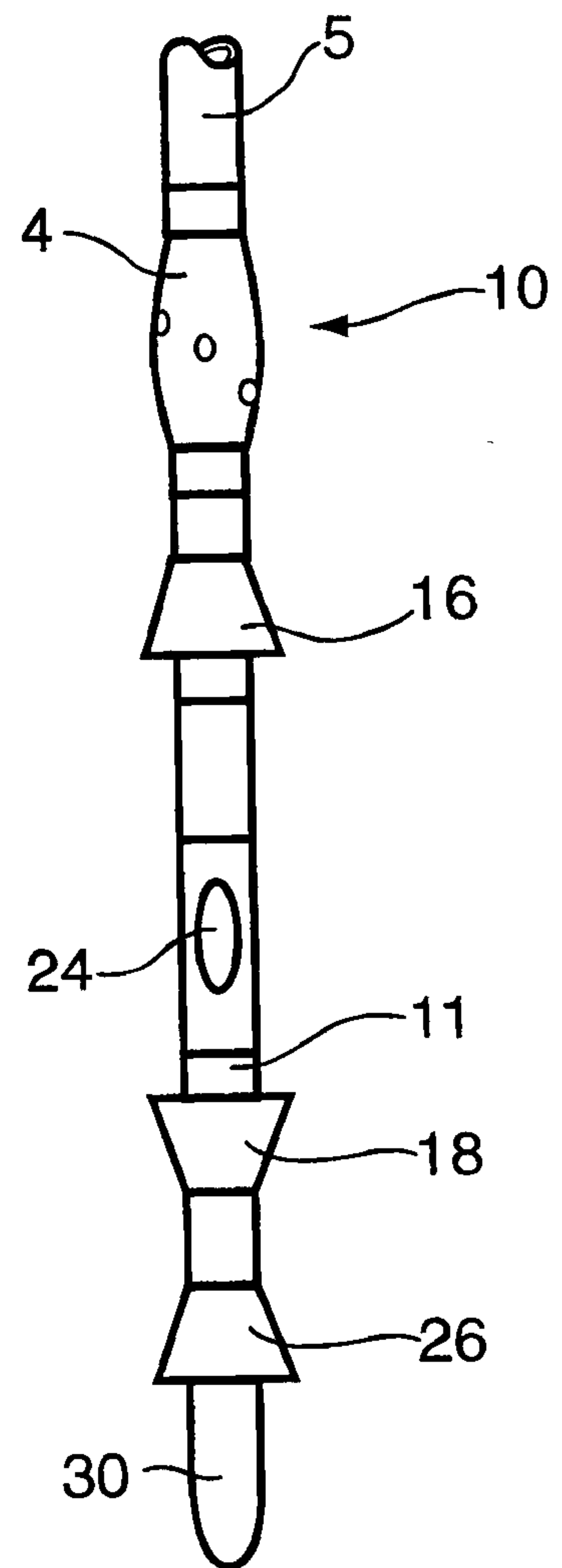

**FIG. 2**

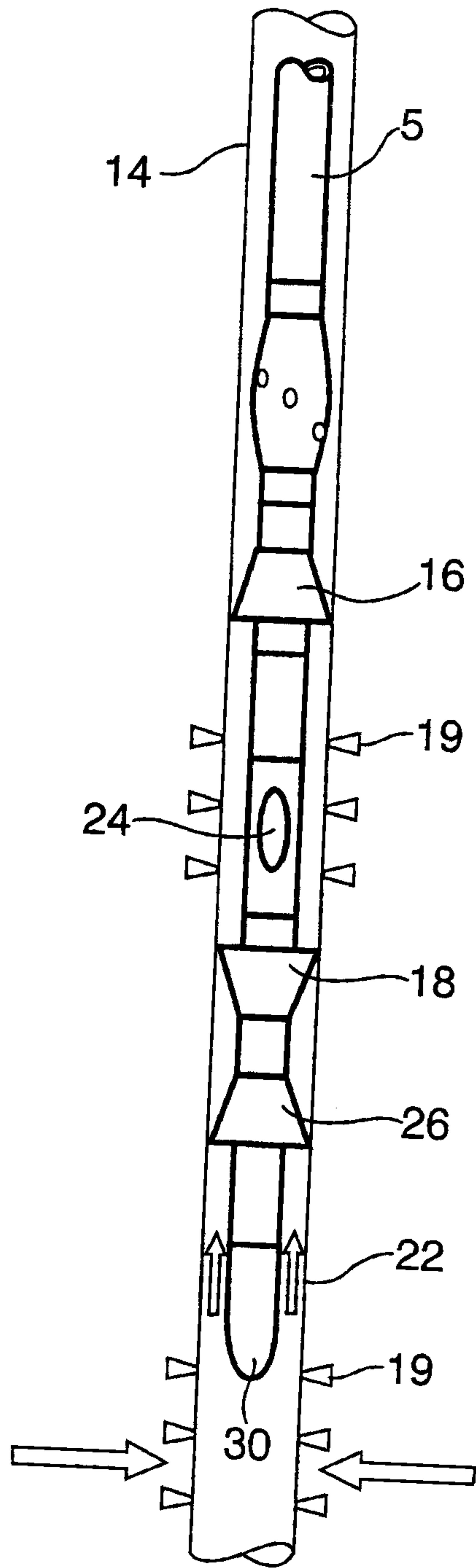

**FIG. 3**

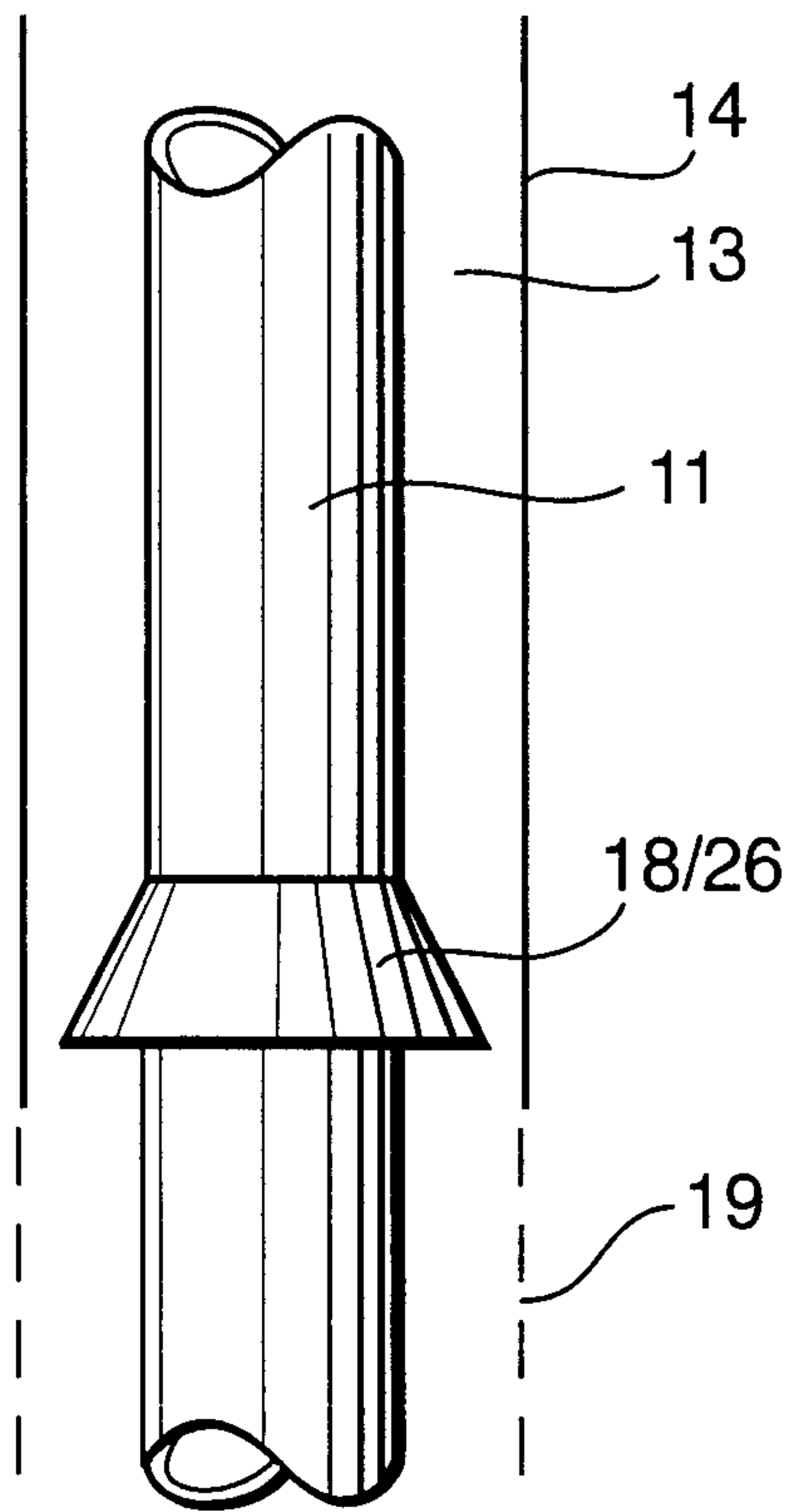

**FIG. 4**

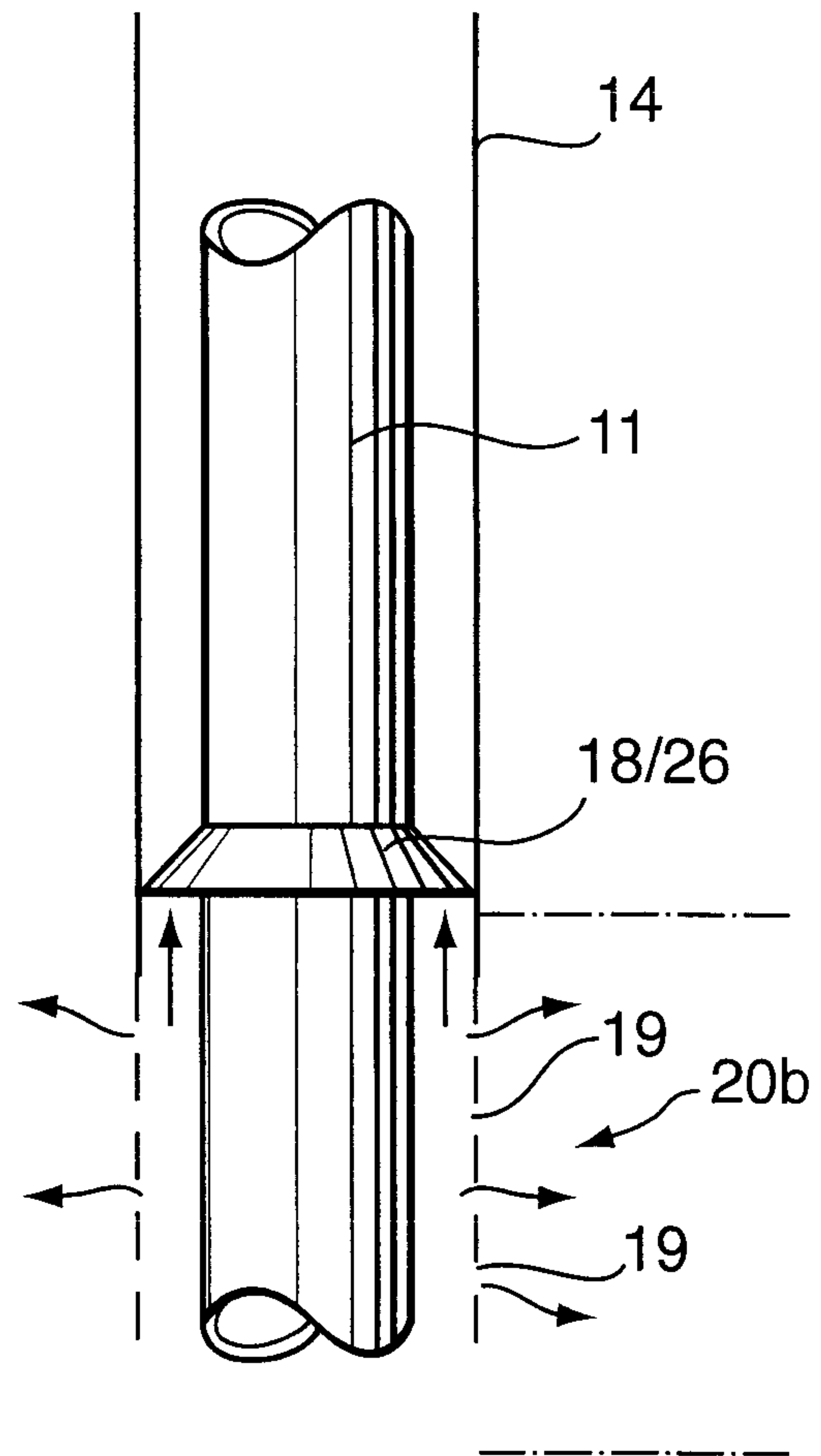

**FIG. 5**

