

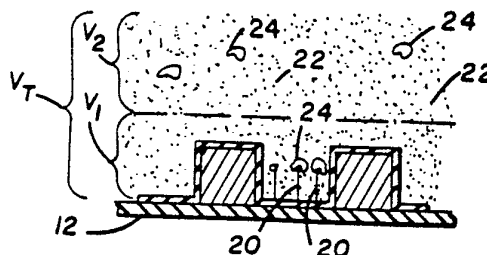

INTERNATIONAL APPLICATION PUBLISHED UNDER THE PATENT COOPERATION TREATY (PCT)

<p>(51) International Patent Classification⁴ : G01N 33/566, 33/545, 27/22</p>	A1	<p>(11) International Publication Number: WO 87/ 03095 (43) International Publication Date: 21 May 1987 (21.05.87)</p>
<p>(21) International Application Number: PCT/US86/02433 (22) International Filing Date: 17 November 1986 (17.11.86) (31) Priority Application Number: 799,761 (32) Priority Date: 19 November 1985 (19.11.85) (33) Priority Country: US</p> <p>(71) Applicant: THE JOHNS HOPKINS UNIVERSITY/ APPLIED PHYSICS LABORATORY [US/US]; Johns Hopkins Road, Laurel, MD 20707 (US). (72) Inventor: NEWMAN, Arnold, L. ; 4128 Warner Street, Kensington, MD 20895 (US). (74) Agents: POJUNAS, Leonard, W., Jr. et al.; Indyk, Poju- nas & Brady, 2001 Jefferson Davis Highway, Suite 409, Arlington, VA 22202 (US).</p>		<p>(81) Designated States: AT (European patent), BE (European patent), CH (European patent), DE (European patent), FR (European patent), GB (European patent), IT (European patent), JP, LU (European patent), NL (European patent), SE (European patent).</p> <p>Published <i>With international search report.</i></p>

(54) Title: CAPACITIVE SENSOR FOR CHEMICAL ANALYSIS AND MEASUREMENT



(57) Abstract

An apparatus for detecting the presence and/or measuring the concentration of an analyte in a fluid by using a biochemical binding system having a substrate (12), a first conductor (10) and a second conductor (14) disposed on substrate (12). The conductor (10) and (14) are spaced apart to form a channel therebetween. A thin insulating layer (16) is coated on the surface of conductors (10, 14) and substrate (12) to form an "open" capacitor. A biospecific binding agent (20) is immobilized on the surface of the insulating layer (16) between the conductors (10, 14). The dielectric constant of the biospecific binding agent (20) is altered by binding of the analyte being detected/measured with the biospecific binding agent (20).

FOR THE PURPOSES OF INFORMATION ONLY

Codes used to identify States party to the PCT on the front pages of pamphlets publishing international applications under the PCT.

AT	Austria	FR	France	ML	Mali
AU	Australia	GA	Gabon	MR	Mauritania
BB	Barbados	GB	United Kingdom	MW	Malawi
BE	Belgium	HU	Hungary	NL	Netherlands
BG	Bulgaria	IT	Italy	NO	Norway
BJ	Benin	JP	Japan	RO	Romania
BR	Brazil	KP	Democratic People's Republic of Korea	SD	Sudan
CF	Central African Republic	KR	Republic of Korea	SE	Sweden
CG	Congo	LI	Liechtenstein	SN	Senegal
CH	Switzerland	LK	Sri Lanka	SU	Soviet Union
CM	Cameroon	LU	Luxembourg	TD	Chad
DE	Germany, Federal Republic of	MC	Monaco	TG	Togo
DK	Denmark	MG	Madagascar	US	United States of America
FI	Finland				

Capacitive Sensor for Chemical Analysis and
Measurement

Corresponding to U.S. Patent Application

5 Serial No. 799,761

Filed: November 19, 1986

Be it known that Arnold L. Newman, a citizen of the
United States of America, and resident of Maryland, has
invented a certain new and useful apparatus for detecting
10 the concentration of an analyte in a fluid medium, of which
the following is a specification:

STATEMENT OF GOVERNMENTAL INTEREST

The Government has rights in this invention pursuant
to Contract No. N00024-85-C-5301, awarded by the Department
15 of the Navy.

BACKGROUND OF THE INVENTION

1. Field of the Invention

The present invention relates to an apparatus for
determining the concentration of an analyte in a fluid
20 medium. More particularly, the invention relates to a
capacitive sensor which is uniquely designed to detect a
change in the dielectric constant caused by biospecific
binding of an analyte with a biochemical binding system.
The biochemical binding system is selected to have specific
25 affinity to the particular analyte or group of analytes
under test.

2. Description of the Prior Art

Various prior art techniques have attempted to measure
the concentration of an analyte in a fluid medium using a
30 binding substance having specific affinity for the analyte.
Immunoassays are used to identify analytes, such as
haptens, antigens and antibodies in a fluid medium. These
immunoassays are based on biospecific binding between
components of a reaction pair, such as the biospecific

binding between an antigen and an antibody.

Tagging one of the components of the binding pair enables more detailed quantification. For example, radioimmunoassay uses a radioisotope as a label for one of
5 the components of the biospecific binding pair. Similarly, fluorescent labels have been used with fluorescent immunoassay.

More recently, attempts have been made to develop an electrochemical sensor which can directly measure analyte
10 concentration. Such sensors would greatly simplify and speed up immunoassay laboratory procedures and provide greater accuracy. These sensors generally detect a change in the physical, electrical or optical properties as one of the binding pairs (generally an antibody) biospecifically
15 binds to its mated pair (generally an antigen). U.S. Patent 4,314,821, issued to Thomas K. Rice detects the change in resonance frequency of a piezoelectric oscillator as antibodies bind to the oscillator. The change in resonant frequency is proportional to the build-up of bound
20 complexes on the oscillator surface (i.e., the build-up of the antibody-antigen complex physically changes the resonance of the oscillator). In U.S. Patent 4,238,757, issued to John F. Schenck, an antigen in a fluid medium is brought into contact with a protein surface layer and
25 alters the charge of the surface layer through an antigen-antibody biospecific binding reaction. A field effect transistor is used to detect this change in charge. Similarly, U.S. Patents 4,444,892 and 4,334,880 detects a change in charge which occurs with certain biospecific
30 binding reactions by using a polyacetylene semiconductive device.

U.S. Patent 4,219,335, issued to Richard C. Ebersole, teaches the use of immune reagents labeled with reactance tags. These tags can be detected electrically since they
35 alter the dielectric, conductive or magnetic properties of the test surface. The patent teaches binding a receptor agent to a test surface. The patient's body fluid containing a certain antibody is added to the test area and

the antibody complexes with the receptor agents." In a second step, the test area is exposed to a second immune reagent that is bonded to a reactance tag. This immune tag complexes with the receptor agent-patient antibody complex, if present, on the test surface. The reactance tag containing a metal or metal-oxide is then detected by electrical means.

U.S. Patent 4,054,646, issued to Ivan Giaever, teaches a method for determining, by electrical means, whether an antigen-antibody reaction produces a monomolecular layer or a biomolecular layer. An antigen is used to coat a metal substrate. The coated substrate is then brought into contact with the fluid suspected to contain a certain antibody. If the antibody is present it adheres to the antigen layer forming a biomolecular layer. If the antibody is not present, a monomolecular layer remains. The next step is to place a mercury drop on the upper layer and measure the capacitance between the mercury drop and the metal substrate. Since the distance between the mercury drop and the metal substrate changes for the biomolecular layer as compared to the monomolecular layer, the measured capacitance also changes. U.S. Patent 4,072,576, issued to Hans Arwin et al, teaches measuring the alternating voltage impedance between two platinum electrode plates immersed in a fluid medium. A biochemical substance, is adsorbed onto the metallic surface. If the fluid under test contains an analyte biospecific to the adsorbed substance binding will occur. For example, an antigen may be absorbed directly on the metal electrodes and a specific antibody in the test fluid may bind to it forming a complex which remains on the surface of the metal electrodes. The capacitance changes depending on whether the surface is coated with a monolayer of the antigen or whether a biomolecular layer, composed of antigen and antibody layers, are adsorbed onto the surface.

SUMMARY OF THE INVENTION

The present invention represents a new type of electrochemical sensor for determining the concentration of

an analyte in a fluid medium. The invention has increased speed and accuracy compared to prior art methods.

The invention utilizes an "open" capacitor which produces a higher electric field in a first volumetric region V1 and a lower electric field in a second volumetric region V2. A change in the dielectric constant within the first region V1 will have a greater effect on the measured capacitance than a change in the dielectric constant within the second region V2. Biospecific binding reactions are used to draw into or release large biochemical molecules from a surface located within the first region V1. Movement of these large molecules displaces molecules of the fluid medium which has a higher dielectric constant. The region V1 is specifically designed so that the large molecules released from the binding surface can rapidly diffuse from region V1 thereby allowing the sensor to respond relatively rapidly.

The sensor has two general embodiments. In the first embodiment, referred to as the direct binding configuration, a surface in region V1 is coated with a layer of immobilized binding agent molecules. The binding agent molecules, may be antibodies immobilized on the substrate surface. The binding agent molecules are biospecific with a particular analyte, such as a virus, bacteria or large molecule. As fluid containing the analyte is introduced onto the sensor and approaches the surface, the analyte binds to the immobilized binding agent. As the analyte binds to the surface, fluid molecules are displaced from region V1 changing the dielectric constant of the "open" capacitor.

The second embodiment, referred to as the competitive binding embodiment, uses a more elaborate biochemical binding system. This method is preferred when the analyte molecules are relatively small. The biochemical binding system has a first layer of the analyte or analyte-analog immobilized on the substrate surface. A second layer of a binding agent, biospecific to the analyte, is bound onto the immobilized analyte layer. The binding agent molecules

are larger molecules and have a lower dielectric constant than the fluid medium. When free analyte molecules in the fluid medium are introduced onto the sensor, they compete with the immobilized analyte molecules to bind with the binding agent molecules. This competitive binding results in a certain amount of the binding agent molecules forming a complex with the free analyte molecules. The free analyte-binding agent complex then diffuses from region VI allowing the higher dielectric fluid molecules to enter region VI, and increase the measured capacitance.

The invention also teaches combining the invented analyte affinity capacitor with at least one reference capacitor to form a differential affinity sensor. The reference capacitor is used to compensate for non-analyte effects. These non-analyte effects include changes in the dielectric constant of the fluid medium caused by a change in temperature, ionic concentration, pH, composition and physical state of the fluid medium, as well as non-specific binding of other proteins contained within the fluid medium.

The invented capacitive sensor can be used to measure the concentration of specific analytes in body fluids and can function as either an in vivo or in vitro sensor. The capacitor sensor can also be used to detect specific substances in the environment. The use of the reference capacitor allows the sensor to continuously measure analyte concentration even though the physical and chemical characteristics of the fluid medium containing the analyte may change. The capacitance affinity sensor can be used to detect a broad range of analytes including: bacteria, viruses, antibodies, large protein molecules, antigens, haptens, polysaccharides, glycoproteins, glycolipids, enzyme inhibitors, enzyme substrates, neurotransmitters and hormones.

BRIEF DESCRIPTION OF THE DRAWINGS

Figures 1a and b are schematic cross-sectional views of the direct binding configuration with Figure 1a showing the structure of the capacitive sensor, and Figure 1b

illustrating the operation of the capacitive sensor to detect the presence of an analyte in a fluid medium.

Figures 2a and 2b are schematic cross-sectional views of the competitive binding configuration with Figure 2a
5 showing the structure of the capacitive sensor and Figure 2b illustrating the operation of the capacitive sensor to detect the presence of an analyte of in a fluid medium.

Figure 3 is a perspective view of an "open" capacitor that uses a plurality of interdigitated fingers.

10 Figure 4 is a top view of an "open" capacitor which uses interleaved conductors.

Figure 5 is a perspective view of an "open" capacitor that uses two parallel conductive wires positioned in an insulator.

15 Figures 6a, b and c are schematic cross-sectional views showing various embodiments of the reference capacitor with Figure 6a showing a reference capacitor which does not contain the biochemical binding system, Figure 6b showing a reference capacitor that uses a "dummy"
20 binding agent for the binding system, and Figure 6c showing a reference capacitor using a binding system composed of a "dummy" analyte and binding agent pair.

Figures 7a and b are schematic cross-sectional views of the differential affinity sensor using a molecular
25 sieve, with Figure 7a showing a single molecular sieve associated with both the affinity and reference capacitors and Figure 7b showing a first molecular sieve associated with the affinity capacitor and a second molecular sieve associated with the reference capacitor.

30 Figure 8 is an embodiment of the differential affinity sensor having an affinity capacitor and a reference capacitor located side-by-side.

Figure 9 is an embodiment of the differential affinity sensor having the affinity capacitor and the reference
35 capacitor located back-to-back.

Figure 10 is a schematic diagram of the circuit to detect the phase difference between the affinity capacitor and the reference capacitor.

Figure 11 is a schematic diagram of a microprocessor system for use with a differential affinity sensor that has an affinity capacitor and at least one reference capacitor.

5 DETAILED DESCRIPTION OF THE PREFERRED EMBODIMENTS

The Capacitive Chemical Sensor can be made chemically sensitive to an analyte by any of a variety of biospecific chemical binding methods. These biospecific binding methods fall into two general categories: (1) competitive
10 binding configuration, and (2) direct binding configuration. As used herein, the term "analyte" means the species to be analyzed.

Direct Binding Embodiment

Figure 1a is a schematic cross-sectional view showing
15 the first general configuration of the sensor, referred to as the direct binding configuration. A first conductor 10 is positioned on the surface of an insulating material or substrate 12; and, a second conductor 14 is also positioned on substrate 12 and disposed a distance from the first
20 conductor 10 creating a channel between the two conductors. The two conductors 10, 14 are coated with a thin electrically insulating layer 16, and the resulting structure forms an "open" capacitor. When a direct
25 alternating voltage is applied across the conductors, an electric field is generated having electric lines of flux 18. As seen generally in Figure 1a, the electric field has a higher field intensity within the volumetric region V1 and a lower field intensity within volumetric region V2.

Molecules of a binding agent 20 are immobilized on a
30 surface in the volumetric region V1. In Figure 1a, the binding agent is immobilized within the channel formed between the two conductors; however, a layer of the immobilized binding agent may coat the entire surface covering the insulated conductors as well as the top
35 surface of the substrate. The techniques for immobilizing the binding agent on the surface are known in the art and will be discussed later in this specification. The binding

agent is an affinity ligand that will bind specifically to the analyte, such as an antibody binds specifically to a particular virus. Alternatively, the affinity ligand may bind to a specific group of analytes, such as nucleotide analogs and lectins bind to certain groups of biochemical analytes.

In Figure 1b, a fluid medium to be tested for a particular analyte is introduced onto the "open" capacitor. The sensor may be immersed into the fluid as in the case of an in vivo medical sensor or an environmental sensor; or, a small volume of the fluid medium may be poured onto the sensor. The fluid medium, shown in Figure 1b, is composed of molecules of fluid 22 and molecules of analyte 24. The fluid medium fills the sensor volume VT which is composed of volumetric regions V1 and V2. The fluid medium may be body fluids such as blood, urine, tears, saliva, semen or it may be other buffered solutions containing the analyte. The fluid molecules 22 will generally include water molecules and small amounts of protein molecules, ionic substances, etc. The dielectric constant of the analyte species must be lower than the dielectric constant of the dominant fluid molecule, generally the water molecule.

In operation, when an analyte species in the fluid medium enters the "open" capacitor sensor and approaches the surface, it binds to the immobilized binding agent (i.e., the ligand layer). This binding will occur until equilibrium is reached between the binding agent, the analyte, and the binding agent-analyte complex (i.e., the ligand-analyte bound species). This equilibrium relationship can be related by the following equation:

$(A) + (B) \rightleftharpoons (A \cdot B)$, where A = Analyte, B = Binding Agent and $(A \cdot C)$ is the Bound Complex.

As the analyte species binds to the surface, fluid molecules from region V1 are displaced and the resulting dielectric constant in a region V1 will decrease. This change in the dielectric constant will be proportional to the analyte species concentration as related by the

following equations:

$$(1) \frac{[A \cdot B]}{[A][B]} = K$$

$$(2) T_A = [A] + [A \cdot B]$$

5

$$(3) T_B = [B] + [A \cdot B]$$

where, [A] = free analyte concentration

[B] = binding agent (ligand)
concentration

[A·B] = bound analyte-ligand complex

10 T_A = total analyte concentration

T_B = total binding agent (ligand)
concentration

It is to be understood that the above equilibrium equations are only approximations and are used only to illustrate the general functioning of the sensor. The quantity T_B , the number of immobilized binding agent molecules, is known; the quantity K is known or can be determined by experimentation; the concentration [A·B] is measured by the change in the dielectric constant of the "open" capacitor; and, the total concentration of the analyte in the test fluid (T_A) is what one wants to determine. For these equations to be generally representative, there should not be a large concentration gradient of the free analyte molecules in region VI. This concentration gradient can be reduced by thermal diffusion over a small volume. Therefore, the "open" face capacitor is specifically designed so that region VI, having the highest electric field flux, is small and there is a short diffusion distance for analyte molecules released from the binding surface to migrate from region VI. It is also within the inventor's contemplation to measure the sensor

15
20
25
30

response during non-equilibrium conditions. The use of kinetic rate equations or empirical data can relate non-equilibrium measurements to total analyte concentration.

Usually, but not exclusively, the analyte species for the direct binding configuration will be large molecules (generally larger than 150,000 daltons) such as bacteria, viruses, other antibodies, or protein molecules. The larger the analyte molecule and the lower its dielectric properties, the greater will be the change in the bulk dielectric constant of region VI as the analyte binds to surface 20. Table I contains anon-limiting example of the type of binding agents (ligands) and analytes that can be used with the direct binding configuration of the sensor:

TABLE I

15	immobilized binding agent	analyte
	bio-specific antibody	bacteria
	bio-specific antibody	viruses
	bio-specific antibody	a second antibody
20	bio-specific antibody	large molecule analytes such as protein molecules

Competitive Binding Embodiment

The second general embodiment of the present invention is shown in the schematic cross-sectional view of Figure 2a. This embodiment is referred to as the competitive binding configuration of the sensor and is particularly useful in sensing analytes that are "small" molecules. In this case, small is defined as significantly smaller in molecular weight than 150,000 daltons (1 dalton = 1 atomic mass unit), the approximate atomic mass of antibodies. A first conductor 26 is positioned on the surface of an insulating material or substrate 27; and, a second conductor 28 also positioned on substrate 27 is disposed a

distance from first conductor 26, creating a channel
between the two conductors. The two conductors 26, 28 are
coated with a thin electrically insulating layer 30, and
the resulting structure forms an "open" capacitor, similar
5 to that used in the first direct binding embodiment. As
with the first embodiment, when a direct or alternating
voltage is applied across the conductors, an electric field
is generated having electric lines of flux 32. As seen
generally in Figure 2a, the electric field has a higher
10 field intensity within the region of V1, and a lower field
intensity within region V2.

The essential difference between the direct and
competitive binding embodiments is that a two-layer
biochemical binding system is used in the latter. A first
15 layer 34 is made from molecules of the analyte or an analog
of the analyte that is immobilized on a surface in the
volumetric region V1. A second layer 36 is made from
molecules of a binding agent that are biospecific with the
analyte. The second layer 36 binds to the immobilized
20 analyte layer 34. The molecules of the binding agent are
generally large compared to the analyte molecules. Figure
2a shows the two-layer binding system positioned within the
channel formed between the two conductors; however, the
two-layer binding system may coat the entire surface
25 covering the insulated conductors as well as the top
surface of the substrate.

In Figure 2b, the fluid medium to be tested for a
particular analyte is introduced onto the "open" capacitor,
as was done with the direct binding embodiment. The fluid
30 medium that can comprise body fluids or a fluid buffer, is
composed of fluid molecules 38 and analyte molecules 40.
The fluid molecules 38 will generally include water
molecules, as well as small amounts of protein molecules,
ionic substances, etc. The binding agent is selected to
35 have a dielectric constant lower than the dielectric
constant of the dominant fluid molecule, generally the
water molecule; and, the binding agent molecule is selected
to be substantially larger than the dominant fluid

molecule.

In operation, when analyte species in the fluid medium enters the "open" capacitor sensor and approaches the two-layer biochemical binding system, it competes with the immobilized analyte 34 to bind with binding agent molecules 36. Since the binding agent molecules are in dynamic equilibrium, there is always a small fraction of these molecules not bound to the immobilized analyte. When free analyte enters into the system, some of these unbound binding agent molecules bind to the free analyte. This results in an overall loss of the binding agent molecules from the surface of the biochemical binding system as equilibrium is restored. The binding agent-free analyte complex diffuses from the binding system to region V2, allowing higher dielectric fluid molecules to enter the higher intensity electric field region V1. The result is an increase in the dielectric constant of the capacitor. This change in the dielectric constant will be proportional to the concentration of the analyte species as related by the following equations:

$$(4) \quad \frac{[A \cdot C]}{[A] [C]} = K_1$$

$$(5) \quad \frac{[A \cdot B]}{[A] [B]} = K_2$$

$$(6) \quad T_A = [A] + [A \cdot C] + [A \cdot B]$$

$$(7) \quad T_B = [B] + [A \cdot B]$$

$$(8) \quad T_C = [C] + [A \cdot C]$$

where [A] = binding agent concentration

[B] = free analyte concentration

[C] = immobilized analyte concentration

[A·B] = free analyte-binding agent complex

[A·C] = immobilized analyte-binding agent complex

T_A = total binding agent concentration

T_B = total free analyte concentration

T_C = total immobilized analyte concentration

It is again to be understood that the above
5 equilibrium equations are only approximations and used only
to illustrate the general functioning of the sensor. For
these equations, the quantity T_A , the number of binding
agent molecules, is known; the quantities K_1 and K_2 are
known or can be determined by experimentation; the
10 concentration $[A \cdot C]$ is measured by the change in the
dielectric constant of the "open" capacitor; the quantity
 T_C , the number of immobilized analyte molecules, is known;
and, the total concentration of the analyte in the test
fluid (T_A) is what one wants to determine. For these
15 equations to be generally representative there (1) should
not be a large concentration gradient of the free analyte
molecules in region V1; and (2) the free analyte-binding
agent complex (A:B) should diffuse rapidly from region V1.
This concentration gradient can be reduced by thermal
20 diffusion over a small volume. Therefore, the "open"
capacitor is specifically designed so that region V1 is
small and there is a short diffusion distance allowing free
analyte-binding agent complexes to move from the surface of
the two-layer biochemical binding system and out of region
25 V1, and the concentration gradient of free analyte in
region V1 is thereby reduced. Applicant envisions that the
use of additional thermal energy or fluid agitation may
increase the mobility of the free analyte molecules as well
as the free analyte-binding agent complex molecules. It is
30 also within the the Applicant's contemplation to measure
the sensor response during nonequilibrium conditions. The
use of kinetic rate equations or empirical testing can
relate nonequilibrium measurements to total analyte
concentration.

35 The binding agent that forms the second layer of the
biochemical binding system can be selected from general or
specific affinity ligands and may include, but is not
limited to, antibodies, lectins, enzymes and receptors.

The immobilized analyte which forms the first layer of the biochemical binding system may be the same molecular substance as the analyte under test, or it may be an analog of the analyte that is biospecific to the binding agent.

5 The immobilized analyte may, for example, be an antigen, a hapten, a polysaccharide, a glycoprotein, a glycolipid, an enzyme inhibitor, an enzyme substrate, a neurotransmitter, a hormone, etc. The immobilized analyte is covalantly bound to the substrate surface. Table II contains non-
 10 limiting examples of the biochemical binding system used in a competitive binding embodiment to test for particular analytes.

TABLE II

	biochemical binding system		analyte	class of sensor
15	immobilized analyte -----	binding agent -----		
	antigen	antibody	antigen	A
	hapten	antibody	hapten	A
20	polysaccharides	lectin	polysaccharides	B
	glycoproteins	lectin	glycoproteins	B
	glycolipids	lectin	glycolipids	B
	enzyme inhibitor	enzyme	enzyme inhibitor	C
25	enzyme substrate	enzyme	enzyme substrate	C
	enzyme inhibitor	enzyme	enzyme substrate	C

neurotrans- mitters	neural receptor	neurotrans- mitters	D
------------------------	--------------------	------------------------	---

hormones	neural receptor	hormones	D
----------	--------------------	----------	---

5 As can be seen from Table II, there are four classes
of the competitive binding sensor. In class A the binding
agent is an antibody specific to the analyte. The analyte
may be an antigen or hapten. The biochemical binding
system comprises a first immobilized layer of the antigen
10 or hapten analyte with a second layer of the biospecific
antibody biochemically bound to the immobilized analyte in
the first layer.

In class B, the binding agent is a lectin, which is a
general ligand specific to a group of analytes. A lectin-
15 based sensor can be made more specific by an appropriate
molecular sieve membrane that excludes larger molecules in
the general analyte group from reacting with the
biochemical binding system. In this class, for example, the
binding system could have a first immobilized layer of a
20 polysaccharide or a membrane protein containing sugar
residues of certain configurations and a second layer of
the general lectin bound to the first layer.

In class C, the binding agent is an enzyme reactive
with an enzyme inhibitor or enzyme substrate. In this
25 class, for example, the binding system could have an
inhibitor for a particular enzyme immobilized on the sensor
surface and a second layer containing the enzyme bound to
the inhibitor in the first layer. With a particular enzyme
substrate in the test fluid, the enzyme binding agent will
30 be drawn from the surface of the binding system.

In class D, the binding agents are neuroreceptors.
The neuroreceptor has its function greatly altered by
various neurotoxins and other agents. The binding system
can have a layer of succinylcholine immobilized on the
35 sensor surface with a second layer of acetylcholine

receptor molecules bound to the first layer. If a neurotoxin, for example, is present in the test fluid, the receptor binding behavior will be altered and it will be released from the binding system surface, thereby altering the dielectric properties of the sensor. It is of course to be understood that these are merely examples of the biochemical binding systems that can be used with the competitive binding embodiment of the present invention.

"Open" Capacitor Structures

10 Figures 3, 4 and 5 show various embodiments of the "open" capacitor structure that can be used for either the direct or competitive binding embodiment of the sensor. Each of these alternative structures of the "open" capacitor contain similar features: (1) the electrical field intensity of the capacitor is higher in a first region V1 than a second region V2; (2) the biochemical binding system is located on a surface area in the first region V1; and, (3) molecules released from the binding system have a short diffusion distance to migrate from the region V1 into region V2.

15 Figure 3 is a perspective view of an "open" capacitor that uses a plurality of interdigitated fingers. Metallic conductors 42 and 44 are positioned on an insulating substrate 46. Each conductor has a plurality of fingers that are disposed in an interdigitated manner relative to the fingers of the other conductors. The interdigitated fingers from both conductors form a plurality of channels that comprise a significant portion of the higher electric field region V1, as seen in Figures 1a and 1b. Known photolithographic etching techniques are used to form the interdigitated fingers on the substrate. The substrate can be made from insulating materials such as Corning 7059 glass or alumina wafers. The interdigitated fingers can be made of copper and gold. Applicant selected 2 mil wide fingers that are approximately 1 mil high and separated by 3 mil spaces, although other dimensions may be used. The interdigitated fingers are covered with an insulating layer

48. Applicant made the insulating layer 48 with a 1-2.5 micron coating of parylene polymer deposited using known deposition processes and a 0.3 micron of SiO₂ deposited using vapor vacuum evaporation deposition; however, alternative electrically insulating material can be used. In the direct binding configuration, a layer of the binding agent is immobilized onto the insulated layer 48. (see, generally Figure 1a). In the competitive binding configuration, the first layer of the two-layer biochemical binding system is immobilized onto the insulated layer 48 (see, generally Figure 2a). Fluid to be tested for a particular analyte is brought into contact with the "open" capacitor as discussed earlier.

Figure 4 is a top view of an "open" capacitor that uses two interleaved conductors covered with an electrically insulated layer. Interleaved metallic conductors 50 and 52 are deposited on insulating substrate 54 using the same technique and materials discussed above. Each conductor is approximately 2 mil by 2 mil with a 2 mil spacing between the interleaved conductors; although, other dimensions may be used. The binding agent, for the direct configuration, and the biochemical binding system, for the competitive embodiment, is immobilized on the surface of the insulated conductor and in the channels between the conductors.

It is to be understood that the interdigitated and interleaved configurations of the two conductors are not limiting examples, and that other geometries can provide the desired features of the "open" capacitor. For example, in Figure 5 an embodiment of the "open" capacitor is shown that uses two parallel conductive wires 56, 58 embedded in a molded insulator 60. The molded insulator 60 is shaped to provide two channels positioned between and running parallel with the conductive wires. If a direct or alternating voltage were applied across conductors 56 and 58, electrical lines of flux 62 would be generated. The volume generally within the two channels will have a higher electric field intensity (similar to region VI in Figures

la or 2a) than the region displaced further radially (similar to region V2 and Figures 1a and 2a). The binding agent, for the direct binding embodiment, and the biochemical binding system, for the competitive binding embodiment, are immobilized onto the surfaces 64 of the molded insulator. As with the interdigitated and interleaved embodiments, the following occurs: (1) the field intensity of the capacitor is higher within the two channels (region V1) than in the radially extended regions (region V2); (2) the biochemical binding system or binding agent is immobilized within the area (V1) having the higher electric field intensity; and (3) molecules removed from the binding system have a short diffusion distance to migrate from the region of the two channels (the region of highers electrical field intensity) the radially extending regions having lower field intensity. This embodiment of the "open" capacitor can be placed in a 1 millimeter dialysis tube 66 which acts as a molecular sieve and the entire sensor can be inserted into a patient's vein or artery to measure the concentration of a particular analyte in the patient's blood. As an alternative to this embodiment, conductive wires 56, 58 are twisted around a center line. This embodiment may provide additional noise immunity.

Further, in each of the embodiments in Figures 3, 4 or 5, the surface area of the binding agent or biochemical binding system can be increased by adding a plurality of ridges, corrugations, or protrusions in region V1. These ridges, corrugations or protrusions are positioned within the channels formed in region V1 are be coated with the immobilized binding agent or biochemical binding system.

Differential Capacitive Sensor

The accuracy of both the direct binding and competitive binding embodiments of the present invention is increased if differential sensing is employed. The differential capacitive sensor uses an analyte affinity sensor (i.e., the direct binding capacitive sensor or the

competitive binding capacitive sensor discussed above) and at least one reference capacitor to compensate for non-analyte effects. The reference capacitor compensates for changes in dielectric constant of the fluid medium caused by changes in temperature, ionic concentration, pH, composition and physical and chemical state of the fluid medium, as well as non-specific binding of proteins that may be in the fluid medium. Figures 6a, b, and c, show various embodiments of the reference capacitor. Each reference capacitor has a first and second conductor 68, 70 positioned on a substrate to form the "open" capacitor as described above. In Figure 6a, a reference capacitor that can be used with both the direct and competitive binding embodiments is shown. This reference capacitor has no protein coat, i.e., it does not have the immobilized binding agent or binding system. In Figure 6b, a reference capacitor for use with the direct binding embodiment is shown. This reference capacitor contains an immobilized layer of a "dummy" binding agent 72. The "dummy" binding agent is selected from the same class as the analyte sensitive binding agent but it is made biospecific to a molecule not found in the test environment. Alternatively, if the reference capacitor uses the same binding agent as the affinity capacitor, a molecular sieve would be used to prevent the analyte from entering the reference capacitor. In Figure 6c, a reference capacitor for use with the competitive binding embodiment is shown. This reference capacitor contains a "dummy" biochemical binding system. The "dummy" binding system uses an immobilized "dummy" analyte 74 specifically reactive with a "dummy" binding agent 76. The "dummy" analyte and binding agent are chosen to have an affinity constant and other physical characteristics that closely match the real analyte and real binding agent. If an antigen-antibody pair are chosen for the binding system of the affinity capacitor, the "dummy" antibody would be selected from the same class of antibodies and from the same type of animal, but would not be biospecific with the analyte antigen. The reference

capacitor may use only the immobilized "dummy" analyte layer, and not the "dummy" binding layer. Alternatively, the reference capacitor may use the same antigen-antibody pair as the affinity capacitor but a molecular sieve would be used to prevent the analyte from entering the reference capacitor. Each of the different types of reference capacitors outlined above compensates for non-analyte changes in the fluid medium. However, a multiplicity of reference capacitors could be used with one affinity capacitor. These reference capacitors would identify the end points and/or other specific points of the dose/response curve. The analyte concentration would be determined by the dielectric change in the analyte affinity capacitor as compared to the boundary values provided by the reference capacitors.

The molecular sieves shown in Figures 7a, b enable the invented affinity sensor to be immersed in the test fluid. The molecular sieve provides two functions: (1) it retains the binding agent molecules in the sensor; and, (2) it selectively screens certain larger molecules from entering the "open" capacitor sensor. Figure 7a is a schematic drawing of a competitive binding differential sensor having an analyte affinity capacitor 78 and reference capacitor 80 (for simplicity the biochemical binding system is not shown in Figure 7a). Fluid molecules flowing into or from the analyte and reference capacitors must pass through molecular sieve 82. The molecular sieve is of a known construction having a pore size that can easily pass the fluid and analyte molecules but will not allow the larger binding agent molecules to escape from the sensor. The pore size for an antigen-antibody binding system would be less than 150,000 daltons to keep the antibody within the sensor. Molecular sieves are particularly useful when the sensor is an in vivo sensor implanted, for example, in a patient's blood stream. The molecular sieve prevents the binding agent molecules released by the binding system from being removed by the blood flow from the sensor.

Figure 7b is a schematic drawing of a competitive

binding differential sensor in which the analyte capacitor 78 and the reference capacitor 80 have separate molecular sieves 84 and 86. In this case, molecular sieve 84 prevents the binding agent molecules from leaving the affinity capacitor. A separate molecular sieve 86 is used with the reference capacitor if the reference capacitor does not use a "dummy" binding system but uses the same binding system as the affinity capacitor. In this case, the molecular sieve 86 provides the following two functions: (1) preventing the binding agent molecules from leaving the reference capacitor and, (2) preventing the analyte molecules from entering the reference capacitor. This form of reference capacitor would be particularly sensitive to changes in the affinity constant of the binding agent-immobilized analyte complex caused by temperature changes. It is to be further understood that a molecular sieve of this nature can be used to filter unwanted larger molecules from interacting with the biochemical binding system. In that case, the pore size of the molecular sieve would be such that fluid and analyte molecules could pass through whereas larger unwanted molecules would be blocked by the molecular sieve. The construction, fabrication and choice of materials for these types of molecular sieves are known in the art.

Figures 8 and 9 show various embodiments for a differential sensor that includes an affinity capacitor and a reference capacitor. Figure 8 is a top view of an affinity capacitor 88 and a reference capacitor 90 located side by side on the same substrate. Figure 9 is a cross-sectional view of an affinity capacitor 92 and a reference capacitor 94 located back-to-back. A metal shield 96 located between the capacitors isolates the electrical field generated by each capacitor. For both the side-by-side and back-to-back embodiments, the fluid medium under test would be simultaneously introduced onto both the affinity and reference capacitors. It is also to be understood that a molecular sieve could be used to encompass either or both the reference capacitor and the

affinity capacitor.

The following non-limiting examples, describe several specific embodiments of the differential sensor:

Example 1. Competitive binding embodiment. The
5 analyte or analyte analog is immobilized on the dielectric
surface forming the first layer of the biochemical binding
system. An analyte specific antibody is conjugated to the
immobilized analyte species and forms the second layer of
the biochemical binding system. The sensor is enclosed by
10 a molecular sieve membrane with pores large enough to be
permeable to the analyte but small enough to confine
antibodies on or close to the sensor. This example is
appropriate for small and medium molecular weight analytes
compared to antibodies, which have molecular weights of
15 approximately 150,000 daltons. With this example, the most
appropriate, but not exclusive, reference capacitor is made
exactly the same way as the analyte sensitive side, except
that a "dummy" analyte and its associated specific "dummy"
antibody is used. The "dummy" analyte and its specific
20 antibody are chosen to have an affinity constant and other
physical characteristics that closely match the analyte and
analyte specific antibody characteristics. The reference
capacitor is also enclosed by a molecular sieve. A second
reference capacitor configuration with no bound "dummy"
25 antibody may also be used.

Example 2. Direct Binding Embodiment. An antibody
specific to particular cells, such as bacteria or to
viruses, or to large molecules, is immobilized on the
surface of the "open" capacitor, forming the binding agent
30 molecules. A large molecule, bacterium, or virus, when
bound to this antibody, will displace a significant amount
of the fluid molecules, (predominantly water molecules)
from the higher density electric field volume V_1 , and thus
cause a detectable change in capacitance. In this case, a
35 molecular sieve membrane would not be required. However,
it would be useful to cover the surface with a mesh. The
reference side of this sensor consists of a capacitor with
a "dummy" antibody immobilized on the insulating substrate.

This antibody is of the same class as the analyte sensitive antibody, but is made specific to a molecule not found in the test environment.

Example 3. Competitive Binding Equipment. This
5 sensor is analogous to Example 1, but uses a receptor in place of an antibody as the second layer of the biochemical binding system. A generic sensor for neurotoxins can be configured using acetylcholine receptors. A substrate, such as succinylcholine, for which the receptor has
10 affinity, is immobilized on the dielectric substrate, forming the first layer of the biochemical binding system. Receptor molecules are then conjugated to the substrate forming the second layer of the biochemical binding system. The receptor molecules are confined within the sensor by
15 the use of a molecular sieve. When a neurotoxin permeates, the receptor is pulled off the surface, and capacitance changes. A reference capacitor is made identical to the analyte sensitive side except that the molecule chosen for surface immobilization is one with an affinity so large
20 that substances of interest will not pull the receptor off the immobilized layer.

The above three examples show models that can be used for a large number of possible sensor configurations. It is to be understood that other binding agents and
25 biochemical binding systems than those shown above are within the scope of this invention.

Figures 10 and 11 are schematic diagrams which illustrate two possible circuits to be used with the differential sensor as taught by the present invention.
30 Figure 10 is a schematic diagram of a circuit to detect the phase difference between the affinity and reference capacitors. A stable oscillator 98 supplies an alternating signal to the affinity capacitor 102 and the reference capacitor 104. These capacitors are placed in parallel
35 with trimmer capacitors 104 and 106. Phase detector 108 detects the phase angle shift between the affinity capacitor 102 and the reference capacitor 104. The phase difference is functionally related to the analyte

concentration in the fluid medium.

Figure 11 is a schematic diagram of a microcomputer system for use with the differential sensor. The system contains an analyte affinity capacitor 110 and a plurality of reference capacitors 112 and 114 (although, a single reference capacitor may be used). The affinity and reference capacitors (110, 112, 114) are brought into contact the fluid under test. Each capacitor is connected to an oscillator (116, 118, 120) and a change in the capacitance will alter the frequency of oscillation of its associated oscillator. The output frequency of each oscillator (116, 118, 120) is fed to an associated counter (122, 124, 126) which sends the frequency count in digital form via bus 128 to microcomputer 130. A look-up Table or Equations similar to Equations (1) through (8) are stored in the microcomputer and a determination of the concentration of the analyte in the fluid medium is made. This value is displayed on output display 132. It is to be understood, that other circuits can also be envisioned once one understands the differential change in capacitance between the analyte affinity capacitor and the reference capacitor as taught by the present invention.

Binding Systems

As described earlier, for the direct binding embodiment, molecules of a binding agent are immobilized on the substrate surface; and, for the competitive binding configuration, a layer of the analyte or analyte-analog is immobilized on the substrate surface to form the first layer of the biochemical binding system. As used herein, immobilized means attaching a molecule by one or more covalent bonds, or other biochemical bonds. Various immobilization techniques are known in the art. The attachment site on the molecule is chosen so that functional groups of the molecule have no interference. For example, in the direct binding embodiment, an antibody (the binding agent) is immobilized on the substrate so that its analyte recognizing and binding site or sites are free

to function. For binding proteins, most reactions are nucleophilic with the nucleophilic group most often NH_2 , OH or SH . Specific examples of biochemical binding systems are found in the art of affinity chromatography and are listed in Table II of Waters, R., "Affinity Chromatography", Analytical Chemistry, Volume 57, No. 11, pp. 1099A-1114A and listed in the figures on pages 19, 21 and 22 of Parikh, I., and P. Cuatrecasas, "Affinity Chromatography", Chemical and Engineering News, August 26, 1985, pp. 17-32 (these articles being incorporated here and by reference). Attachment reactions include the use of Cyanogen Bromide, Active Esters, Epoxide, Trisyl Chloride, Carbonyldiimidazole, Thiol and Diazonium reagents.

By way of illustration, the following experimental example performed by the Applicant shows covalent attachment of the biochemical binding system to the "open" affinity capacitor. The example is a sensor to detect the Trichothecene mycotoxin T-2, which is found in the environment and is produced by the fungal species Fuarium. Trichothecene mycotoxin is an agricultural toxin causing the loss of grain yield on various food crops. It has been implicated in human and animal mucotoxicoses.

Experimental Example

1. The "open" capacitor is coated with a 0.3 micron thick layer of SiO_2 . Without care to prevent hydration of the surface (dry vacuum), the surface becomes composed of silanol groups:



The surface will have approximately 10 silanols per m^2 .

2. Amino groups are attached to the SiO_2 surface for later attachment of proteins, using the following steps:

- a. - soak substrate in 10% γ -aminopropyl-triethoxysilane $[(\text{EtO})_3\text{-Si-(CH}_2)_3\text{-NH}_2]$ and dry toluene overnight at room temperature.
- b. wash with dry toluene; and,
- c. dry at 60 degrees C for two hours. The aminosilanized surface will be:

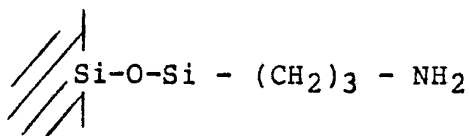

3. The surface is now ready for introduction of the Trichothecene (T-2) groups.

5 a. The T-2 molecule is converted to a hemisuccinate derivative by heating it in the presence of Pyridine and Succinicyanhydride. This derivization was necessary in this example, but some hemisuccinates can be bought off the shelf. For example, in making a hydrocortisone sensor, hydrocortisone hemisuccinate can be purchased directly from
10 Sigma Chemical Co., and others.

b. The hemisuccinate derivative of the analyte is then conjugated to the γ - amino function of the silanized surface, using a water soluble carbodiimide as a catalyst. The T-2 analyte is now immobilized on the surface of the
15 "open" capacitor and the surface appears as follows:

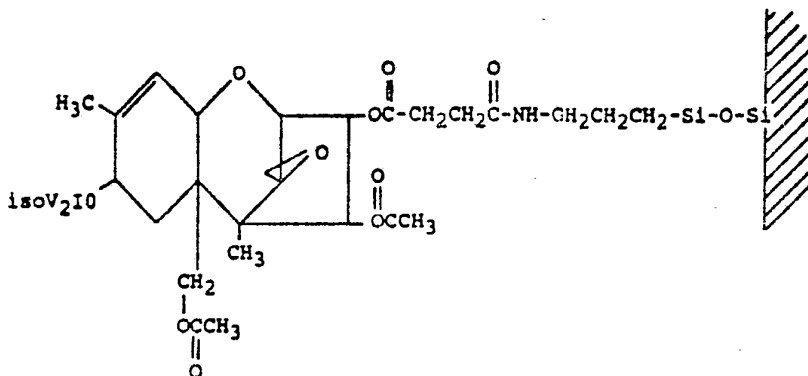

4. The second layer of the biochemical binding system is produced by adding the anti T-2 toxin antibody to fluid bathing the surface of the open face capacitor. The antibodies will bind with an affinity similar to that in
20 the standard immunoassay (5.28×10^7 liters/mol). The resulting biochemical binding system has a first layer of the T-2 analyte immobilized on the surface and a second layer of the anti T-2 toxin antibody specifically bound to the immobilized layer.

25 Since the anti T-2 antibodies and the immobilized T-2 toxin are in dynamic equilibrium, an influx of free T-2

toxin molecules would perturb the equilibrium and draw the antibodies from the immobilized surface forming free analyte-antibody complexes. Removal of the free analyte-antibody complexes from the region of the capacitor sensor having higher field intensity, region VI, causes a change in the capacitance that is a direct indication of the concentration of free T-2 molecules in the fluid medium.

Obviously many modifications and variations of the present invention are possible in light of the above teachings. It is therefore to be understood that within the scope of the appended claims the invention may be practiced otherwise than as specifically described.

WHAT IS CLAIMED IS:

1. A device for detecting the presence of an analyte in a fluid, said device comprising:

a capacitive means for generating a time-varying electric field within said device, said device having a
5 first volumetric region of higher average electric field intensity and a second volumetric region of lower average electric field intensity;

a biochemical binding means, localized on a surface within said first volumetric region of higher average
10 electric field intensity, for concentrating analyte onto said biochemical binding means and into said first volumetric region thereby resulting in fluid displacement from said first volumetric region to said second volumetric region, said analyte having a different bulk dielectric
15 constant than the fluid; and,

a means, associated with said capacitive means, responsive to the average dielectric constant in said first volumetric region, wherein relative analyte and fluid movement between said first volumetric region and said
20 second volumetric region causes a change in said average dielectric constant.

2. The device of claim 1, wherein said capacitive means comprises a first conductor and a second conductor disposed a distance from said first conductor, surfaces of said first and second conductor adapted to be exposed to
5 fluid under test are coated with electrically insulating material, and wherein said surface, on which said biochemical binding means is localized, is positioned between and remote from said first and second insulated conductor.

3. The device of claim 1, wherein said capacitive means comprises a first conductor and a second conductor disposed a distance from said first conductor, surfaces of said first and second conductor adapted to be exposed to
5 fluid under test are coated with electrically insulating material, and wherein said electrically insulating layer forms said surface on which said biochemical binding means is localized.

4. The device of claim 1, wherein said surface, on which said biochemical binding means is localized, is a surface of an electrically insulating material adapted to be exposed to fluid under test.

5. The device of claim 1, wherein said biochemical binding means reversibly binds with said analyte in accordance with analyte concentration in said fluid, wherein a reduction of analyte concentration in said fluid results
5 in fluid returning to said first volumetric region from said second volumetric region.

6. The device of claim 1, wherein said biochemical binding means comprises a layer of a binding agent specifically reactive with said analyte and adapted to form an analyte/binding agent bond.

7. The device of claim 6, wherein said biochemical binding means further comprises linking molecules for immobilizing said binding agent to said surface and extending said binding agent a distance removed from the
5 fluid/surface interface.

8. The device of claim 6, wherein said binding agent is an affinity ligand selected to bind specifically to said analyte.

9. The device of claim 8, wherein said binding agent is a biospecific antibody.

10. The device of claim 9, wherein said analyte is selected from the group consisting of bacteria, viruses and antibodies.

11. The device of claim 1, wherein said responsive means further comprises a differential means for comparing capacitance changes detected by said responsive means with the average dielectric constant in said second volumetric
5 region.

12. The device of claim 11, wherein said differential means includes:

a reference capacitor means responsive to the average dielectric constant in said second volumetric region.

13. The device of claim 1, wherein said capacitive means comprises:

a first conductor having an electrically insulating layer;

5 a second conductor having an electrically insulating layer and disposed a distance from said first conductor;

a means for generating said electric field between said first and second conductor; and,

10 wherein said responsive means comprises a circuit means responsive to changes in capacitance between said first and said second insulated conductor.

14. The device of claim 13, wherein said first and second insulated conductors are positioned on a substrate to form an "open" face capacitor.

15. The device of claim 14, wherein said biochemical binding means is disposed on the surface of said "open" face capacitor.

16. The device of claim 13, wherein said first conductor comprises a plurality of fingers disposed on a substrate and extending a distance above said substrate, and wherein said second conductor comprises a plurality of
5 fingers disposed on said substrate and extending a distance above said substrate, fingers of said second conductor are interdigitated with fingers of said first conductor, whereby channels are formed between said first and said second conductor.

17. The device of claim 16, wherein said a plurality of fingers are coated with an electrically insulating layer.

18. The device of claim 17, wherein said biochemical binding means is immobilized on said electrically insulating layer.

19. The device of claim 17, wherein said biochemical binding means is immobilized within said channels formed between said fingers of said first and second conductor.

20. The device of claim 17, wherein said biochemical binding means is immobilized on structures that are positioned within said channels formed between said fingers of said first and second conductors.

21. The device of claim 16, wherein said fingers of said first and second conductor are interdigitated.

22. The device of claim 11, wherein said first and second conductors are parallel conductive wires imbedded in a molded insulator, wherein said molded insulator is shaped to provide at least one channel positioned between and
5 running parallel with said conductive wires, and wherein said biochemical binding means is immobilized within said at least one said channel.

23. The device of claim 13, further comprising a reference means responsive to the average dielectric constant of fluid in said second volumetric region.

24. The device of claim 23, wherein said reference means comprises a reference capacitor means responsive to changes in the dielectric constant of said fluid.

25. The device of claim 24, wherein said reference capacitor means comprises:

a first reference conductor having an electrically insulating layer;

5 a second reference conductor having an electrically insulating layer and disposed a distance from said first conductor;

a means for generating a reference electric field between said first and said electrical conductors, wherein
10 said reference electric field has a higher average intensity in a first reference volumetric region in a lower average intensity in a second reference volumetric region; and,

a reference circuit means responsive to changes in capacitance in said first reference volumetric region.

26. The device of claim 25, further comprising a "dummy" biochemical binding means, positioned in said first reference volumetric region, said "dummy" biochemical binding means is not biospecific to said analyte under
5 test.

27. The device of claim 25, wherein a portion of said biochemical binding means is positioned within said first reference volumetric region of said reference capacitor means, and wherein a molecular sieve means encompasses said
5 first and second reference volumetric regions of said reference capacitor means, said membrane means having a porous size selected to permit the passage of fluid molecules but to inhibit passage of analyte molecules into said first and second reference volumetric region.

28. The device of claim 24, further comprising a differential means for comparing the capacitance detected by said responsive means with the capacitance detected by said reference capacitor means.

29. A device for detecting the presence of an analyte in a fluid, said device comprising a sensing capacitor adapted to be exposed to said fluid including:

5 a first conductor coated with an electrically insulated layer;

10 a second conductor coated with an electrically insulated layer and disposed a distance from said first conductor so that application of time-varying voltage across said first and second conductor will generate a time-varying electric field having a higher average field intensity in a first volumetric region localized near a surface and a lower average field intensity in a second volumetric region, fluid displaced from said first volumetric region will move into said second volumetric region;

15 a biochemical binding means localized on said surface for concentrating analyte into said first volumetric region whereby fluid is displaced from said first volumetric region into said second volumetric region, said analyte having a different bulk dielectric constant from said fluid.

30. The device of claim 29, wherein said biochemical binding means comprises a layer of a binding agent specifically reactive with said analyte and adapted to form an analyte/binding agent bond.

31. The device of claim 30, wherein said biochemical binding means further comprises a linking molecule for immobilizing said binding agent onto said surface.

32. The device of claim 30, wherein said binding agent is an affinity binding agent selected to bind specifically to the analyte.

33. The device of claim 30, wherein said binding agent is a biospecific antibody.

34. The device of claim 30, wherein said first conductor comprises a plurality of fingers deposited on a substrate and extending a distance above said substrate, and wherein said second conductor comprises a plurality of
5 fingers deposited on said substrate and extending a distance above said substrate, fingers of said second conductor are interdigitated with fingers of said first conductor, where channels are formed between said first and second conductor,
10 and wherein said plurality of fingers are coated with an electrically insulating layer.

35. The device of claim 29, further comprising:
a reference capacitor adapted to be exposed to said fluid including:
a first reference conductor coated with an
5 electrically insulating layer, and
a second reference conductor coated with an electrically insulating layer and disposed a distance from said first conductor, wherein said first and second electrically insulating conductors are adapted
10 to be exposed to said fluid and wherein application of a voltage across said first and second reference conductor will generate an electric field having higher field intensity in a first reference volumetric region and a lower field intensity in a second reference
15 volumetric region.

36. The device of claim 35, further comprising a "dummy" biochemical binding means, positioned in said first reference volumetric region, said "dummy" biochemical binding means is not biospecific to said analyte under
5 test.

37. The device of claim 35, wherein a portion of said biochemical binding means is positioned within said first reference volumetric region of said reference capacitor , and wherein a molecular sieve means encompasses said first and second reference volumetric regions of said reference capacitor, said membrane means having a pore size selected to permit the passage of fluid molecules but to inhibit passage of analyte molecules into said first and second reference volumetric region.

38. The device of claim 35, wherein said sensing capacitor and said reference capacitor are positioned on a substrate that is adapted to be exposed to said fluid under test.

39. The device of claim 35, wherein a mesh is operably associated with said substrate so that a small volume above said substrate containing said sensing and reference capacitors is isolated from large particles in the environment.

40. The device of claim 35, wherein said first reference conductor comprises a plurality of fingers disposed on a substrate and extending a distance above said substrate and wherein said second reference conductor comprises a plurality of fingers disposed on said substrate and extending a distance above said substrate, fingers of said first conductor are interdigitated with fingers of said second conductor, whereby channels are formed between said first and second conductor, and wherein said plurality of fingers are coated with an electrically insulating layer.

41. A method for detecting the presence of an analyte in a fluid, comprising the steps of:

concentrating analyte onto a biochemical binding means, whereby said analyte displaces fluid from a volume adjacent to said biochemical binding means; and, detecting the average dielectric constant in said volume adjacent to said biochemical binding means.

42. The method of claim 41, wherein said detecting step further involves the steps of:

generating a time-varying electric field having a higher average electrical field intensity in said volume adjacent to said biochemical binding means and a lower average field intensity in a second volumetric region, wherein fluid displaced by said analyte from said adjacent volume moves into said second volumetric region; and, sensing a change in capacitance as fluid moves from said adjacent volumetric region into said second volumetric region.

43. The method of claim 42, wherein said detecting step involves the further steps of:

determining the average dielectric constant of said fluid; and, comparing said sensed capacitance with said average dielectric constant of said fluid.

44. A method for detecting the presence of an analyte in a fluid, comprising the steps of:

generating a time-varying electric field within a volume of fluid under test by using a capacitor that produces a first volumetric region of higher electric field intensity localized near a surface and a second volumetric region of lower average electric field intensity; concentrating analyte from said fluid under test into said first volumetric region by localizing a biochemical binding means on said surface; providing a path for movement of fluid between said first volumetric region and said second volumetric region, wherein said fluid is displaced along said path as analyte is concentrated into said first volumetric region; and, sensing the capacitance of said capacitor, wherein relative analyte and fluid movement between said first volumetric region and said second volumetric region causes a change in said capacitance.

45. The method of claim 44, wherein said concentrating step comprises the step of reversibly binding said analyte onto said biochemical binding means in response to analyte concentration in fluid under test, wherein a reduction of
5 analyte concentration in said fluid under test reduces the analyte concentrated by said biochemical binding means in said first volumetric region.

46. The method of claim 44, wherein said concentrating step comprises the step of binding said analyte onto a biochemical binding means biospecifically reactive with the analyte to form an analyte/biochemical binding means bond.

47. The method of claim 44, further comprises the step of determining the average dielectric constant of the fluid.

48. The method of claim 47, further comprising the step of comparing the sensed capacitance with the determined average dielectric constant of the fluid.

49. A device for detecting the presence of molecules of analyte in a fluid medium, said device comprising:

a biochemical binding system positioned in a first volumetric region and comprising:

5 first layer molecules immobilized on a surface within said first volumetric region,

second layer binding agent molecules conjugated onto said immobilized first layer molecules, said binding agent molecules having the following properties:

10 a. a dielectric constant different from said fluid,

b. biospecifically reactive with both said immobilized first layer molecules and molecules of said analyte in said fluid,

15 wherein exposure of said biochemical binding system to a fluid medium containing analyte molecules reduces the percentage of said binding agent molecules bound to said first layer molecules through the formation of binding agent/analyte complexes; and,

20 a means responsive to the average dielectric constant in said first volumetric region.

50. The device of claim 49, wherein said responsive means comprises:

a capacitor means for generating an electric field having a higher field intensity in said first volumetric region and a lower field intensity in a second volumetric region, wherein said first and second volumetric regions comprise a total volumetric area.

51. The device of claim 50, wherein said responsive means detects a change in the dielectric constant in said first volumetric region as said fluid moves into said first volumetric region as said binding agent/analyte pairs migrate from said first volumetric region into said second volumetric region.

52. The device of claim 51, wherein said first volumetric region is small relative to said second volumetric region, and wherein said surface within said first volumetric region is a short diffusion distance from said second volumetric region.

53. The device of claim 50, wherein said capacitor means comprises:

a first conductor having an electrically insulating layer, and second conductor having an electrically insulating layer and disposed a distance from said first conductor;

a means for generating said electric field between said first and second conductor; and,

a circuit means responsive to changes in capacitance between said first and second insulating conductor.

54. The device of claim 53, wherein said first conductor comprises a plurality of fingers disposed on a substrate and extending a distance above said substrate, and wherein said second conductor comprises a plurality of fingers disposed on said substrate and extending a distance above said substrate, fingers of said second conductor are interdigitated with fingers of said first conductor, whereby channels are formed between said first and second conductor, and wherein said plurality of fingers are coated with an electrically insulating layer.

55. The device of claim 53, wherein said biochemical binding system is immobilized on said electrically insulating layer.

56. The device of claim 53, wherein said biochemical binding system is immobilized within said channels formed between said fingers of said first and second conductor.

57. The device of claim 53, wherein said biochemical binding system is immobilized on ridges that are positioned within said channels formed between said fingers of said first and second conductors.

58. The device of claim 53, wherein said fingers of said first and second conductors are interdigitated.

59. The device of claim 50, wherein said first and second conductors are parallel conductive wires embedded in a molded insulator, wherein said molded insulator is shaped to provide at least one channel position between and running
5 parallel with said conductive wires, wherein said biochemical binding system is immobilized within said at least one channel.

60. The device of claim 50, further comprising a reference means responsive to the average dielectric constant of a fluid in said second volumetric region.

61. The device of claim 60, wherein said reference means comprises a reference capacitor means responsive to changes of the dielectric constant in said fluid.

62. The device of claim 60, wherein said reference capacitor means comprises:

a first reference conductor having an electrically insulating layer, a second reference conductor having
5 electrically insulated layer and disposed a distance from said first conductor;

a means for generating a reference electrical field between said first and second conductor, wherein said electrical field has a higher field intensity in a first
10 reference volumetric region and a lower field intensity in a second volumetric region; and,

a reference circuit means responsive to changes in capacitance between said first and second insulated reference conductors.

63. The device of claim 62, further comprising a "dummy" biochemical system, positioned in said first reference volumetric region, said "dummy" biochemical binding system comprising first layer molecules immobilized
5 on a surface within said first reference volumetric region and second layer binding agent molecules conjugated onto said first layer molecules, wherein said second layer binding agent molecules are not biospecific to said analyte molecules.

64. The device of claim 62, further comprising a "dummy" biochemical system, positioned in said first reference volumetric region, said "dummy" biochemical binding system comprising first layer molecules immobilized
5 on a surface within said first reference volumetric region, said first layer molecules are not biospecific to said analyte molecules.

65. The device of claim 62, wherein a portion of said biochemical binding system is positioned within said first reference volumetric region of said reference capacitor means, and wherein a molecular sieve means encompasses said
5 first and second reference volumetric regions of said reference capacitor means, said membrane means having a pore size selected to permit the passage of fluid molecules but to inhibit passage of analyte molecules into said first and second volumetric region.

66. The device of claim 62, further comprising a differential means for comparing the capacitance detected by said capacitive means with the capacitance detected by said reference capacitive means.

67. The device of claim 49, wherein said first layer molecules are selected from the group consisting of the analyte molecule under test, and analog molecules of said analyte molecules that are biospecific to said second
5 layer binding agent molecules.

68. The device of claim 49, wherein said biochemical binding system further comprises linking molecule for immobilizing said first layer molecules onto said surface within said first volumetric region.

69. The device of claim 68, wherein said first layer molecules are covalently bound to said surface within said first volumetric region.

70. The device of claim 49, wherein said second layer binding agent molecules are biological molecules having an affinity to the analyte.

71. The device of claim 49, wherein said second layer binding agent molecules are selected from the group consisting of antibodies, lectins, enzymes and receptors.

72. The device of claim 49, wherein said first layer immobilized molecules are selected from the group consisting of antigens, haptens, polysaccharides, polyglycoproteins, glycolipids, enzyme inhibitors, enzyme substrates,
5 neurotransmitters and hormones.

73. The device of claim 49, wherein said analyte is an antigen, and said second layer binding agent is an antibody biospecific to said antigen analyte, and wherein said first layer immobilized molecules are selected from the
10 group consisting of said antigen analyte and analogs to said antigen analyte that are biospecific to said second layer binding agent molecules.

74. The device of claim 49, wherein said analyte is a hapten, and said second layer binding agent is an antibody biospecific to said hapten analyte, and wherein said first layer immobilized molecules are selected from the group
5 consisting of said hapten analyte and analogs to said hapten analyte that are biospecific to said second layer binding agent molecules.

75. The device of claim 49, wherein said second layer binding agent molecules are a lectin that is specific to a group of analytes.

76. The device of claim 75, wherein said first layer immobilized molecules are selected from the group consisting of polysaccharides, glycoproteins and glycolipids.

77. The device of claim 49, wherein said second layer binding layer agent is an enzyme.

78. The device of claim 77, wherein said first layer immobilized molecules are selected from the group consisting of enzyme inhibitors and enzyme substrates.

79. The device of claim 49, wherein said second layer binding agent is a neuroreceptor.

80. The device of claim 79, wherein said first layer immobilized molecules are selected from the group consisting of neurotransmitters and hormones.

81. The device of claim 50, further comprising a membrane surrounding said total volumetric area, wherein said membrane has a plurality of pores adapted to pass analyte and fluid molecules.

82. The device of claim 81, wherein said pore size is selected to pass analyte and fluid molecules but to prevent second layer binding agent molecules from escaping from said total volumetric area.

83. The device of claim 82, wherein said pore size is chosen to selectively pass molecules below a certain size, wherein said membranes can selectively screen certain molecules from entering said total volumetric area.

84. A device for detecting the presence of an analyte in a fluid, said device comprising:

a sensing capacitor adapted to be exposed to said fluid including:

5 a first conductor coated with an electrically insulated layer;

a second conductor coated with an electrically insulated layer and disposed a distance from said first conductor so that application of a time-varying voltage across said first and second conductor will generate a time-varying electric field having a higher field intensity in a first volumetric region and a lower field intensity in a second volumetric region, said first and second volumetric regions comprising a total volumetric region,

a biochemical binding system positioned in said first volumetric region and comprising:

first layer molecules immobilized on a surface within said first volumetric region,

20 second layer binding agent molecules conjugated onto said immobilized first layer molecules, said binding agent molecules having the following properties: (a) larger in size than dominant fluid molecules and molecules of said analyte; (b) a dielectric constant different from said fluid, and
25 (c) biospecifically reactive with both said immobilized first layer molecules and said molecules of said analyte in said fluid,

wherein exposure of said biochemical binding system to a fluid medium containing analyte molecules displaces a percentage of said binding agent molecules from said biochemical binding system through competitive binding to form binding agent/analyte pairs, migration of said binding agent/analyte pairs from said first volumetric region to
30 said second volumetric region changes the average dielectric constant in said first volumetric region.
35

85. The device of claim 84, wherein said first volumetric region is small relative to said second volumetric region, and wherein said surface within said first volumetric region is a short diffusion distance from
5 said second volumetric region.

86. The device of claim 85, wherein fluid diffuses into said first volumetric region as said binding agent/analyte pairs migrate from said first volumetric region to said second volumetric region causing a change in
5 the average dielectric constant in said first volumetric region.

87. The device of claim 84, wherein said first conductor comprises a plurality of fingers disposed on a substrate and extending a distance above said substrate, and wherein said second conductor comprises a plurality of
5 fingers disposed on said substrate and extending a distance above said substrate, fingers of said second conductors are interdigitated with fingers of said first conductor, whereby channels are formed between said first and second conductor, and wherein said plurality of fingers are coated with an
10 electrically insulating layer.

88. The device of claim 87, wherein said biochemical binding system is immobilized on said electrically insulating layer and within said channels.

89. The device of claim 84, wherein said first layer molecules are selected from the group consisting of analyte molecules under test, and analog molecules of said analyte molecules that are biospecific to said second layer binding
5 agent molecules.

90. The device of claim 84, wherein said second layer binding agent molecules are biological molecules having an affinity to the analyte under test.

91. The device of claim 84, wherein said second layer binding agent molecules are selected from the group consisting of antibodies, lectins, enzymes and receptors.

92. The device of claim 84, further comprising a membrane means for isolating said total volumetric area from fluid outside said total volumetric area, wherein said membrane has a plurality of pores adapted to pass analyte
5 and fluid molecules but to prevent second layer binding agent molecules from escaping from said total volumetric area.

93. The device of claim 84, further comprising:
a reference capacitor adapted to be exposed to said fluid including:

a first reference conductor coated with an
5 electrically insulating layer, and

a second reference conductor coated with an electrically insulating layer and disposed a distance from said first conductor, wherein said first and second electrically insulating conductors are adapted
10 to be exposed to said fluid, application of a time-varying voltage across said first and second reference conductor will generate a time-varying electric field having a higher field intensity in a first reference volumetric region and a lower field intensity in a
15 second reference volumetric region.

94. The device of claim 93, further comprising a "dummy" biochemical system, positioned in said first reference volumetric region, said "dummy" biochemical binding system comprising first layer molecules
5 immobilized on a surface within said first reference volumetric region and second layer binding agent molecules conjugated onto said first layer molecules, wherein said second layer binding agent molecules are not biospecific to said analyte molecules.

95. The device of claim 93, further comprising a "dummy" biospecific system, positioned in said first reference volumetric region, said "dummy" biochemical binding system comprising first layer molecules immobilized
5 on a surface within said first reference volumetric region, said first layer molecules are not biospecific to said analyte molecules.

96. The device of claim 93, wherein a portion of said biochemical binding system is positioned within said first reference volumetric region of said reference capacitor, and wherein a molecular sieve means encompasses said first and second reference volumetric regions of said reference capacitor, said membrane means having a pore size selected to allow the passage of fluid molecules but to inhibit passage of analyte molecules into said first and second volumetric region.

97. The device of claim 93, wherein said first reference conductor comprises a plurality of fingers disposed on a substrate and extending a distance above said substrate and wherein said second reference conductor comprises a plurality of fingers disposed on said substrate and extending a distance above said substrate, fingers of said first conductors are interdigitated with fingers of said second conductor, whereby channels are formed between said first and second conductor, and wherein said plurality of fingers are coated with an electrically insulating layer.

98. The device of claim 93, where said first and second conductor and said first and second reference conductor are positioned on a single substrate.

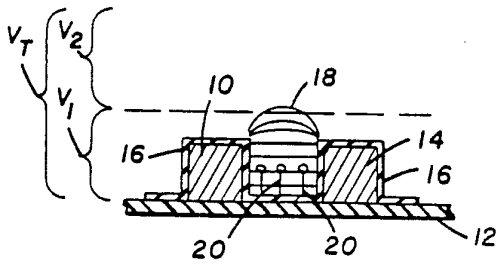

FIG. 1a

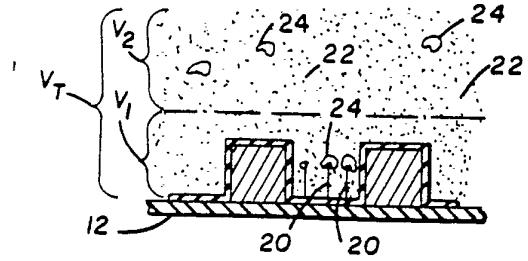

FIG. 1b

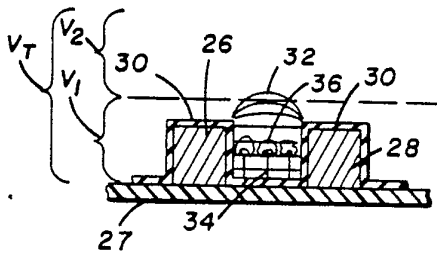

FIG. 2a

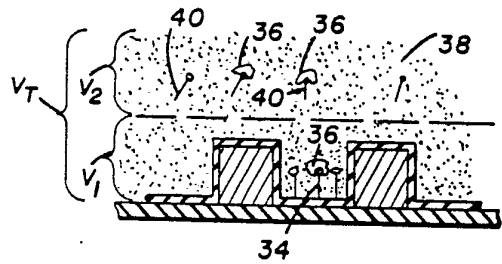

FIG. 2b

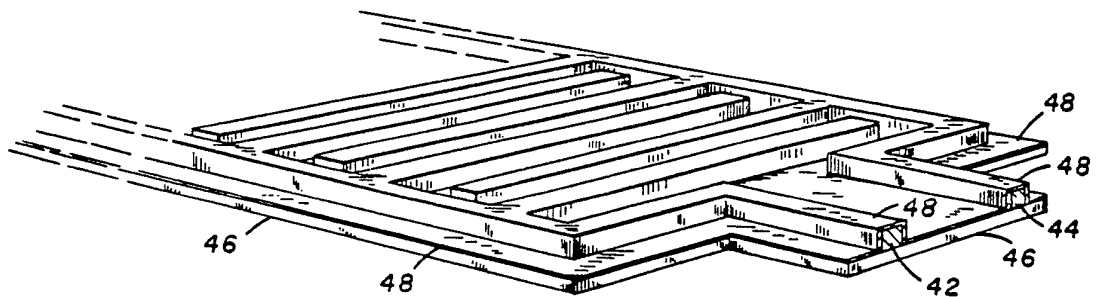

FIG. 3

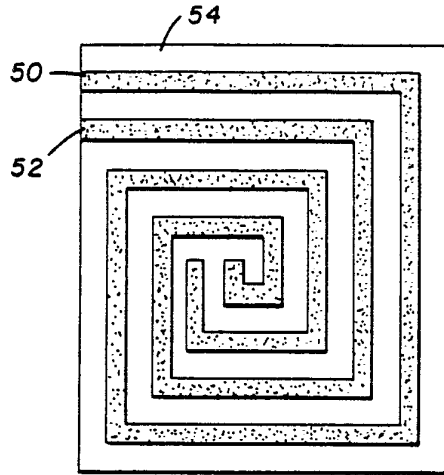

FIG. 4

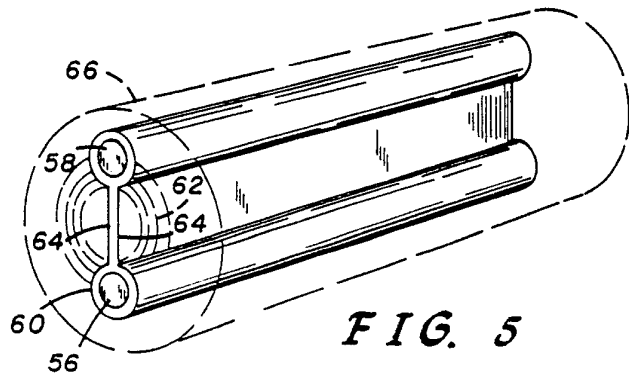

FIG. 5

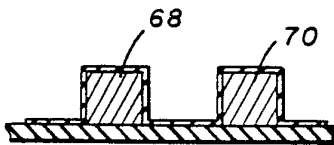

FIG. 6a

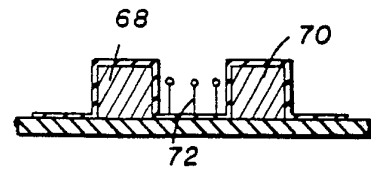

FIG. 6b

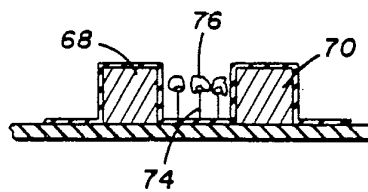

FIG. 6c

3 / 4

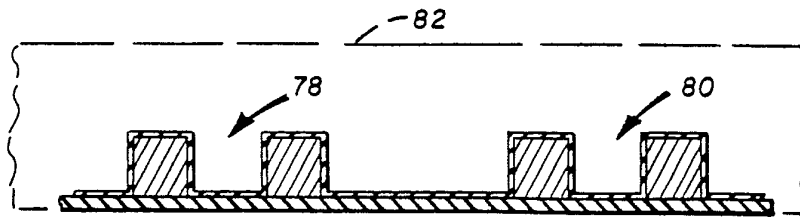

FIG. 7a

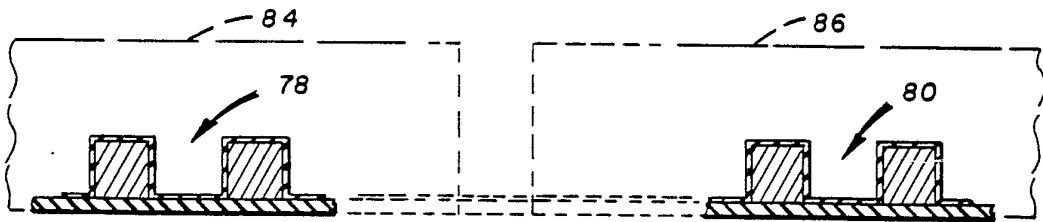

FIG. 7b

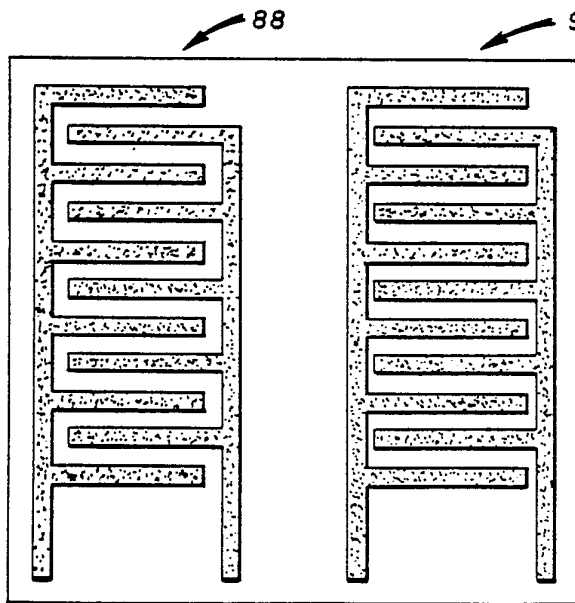

FIG. 8

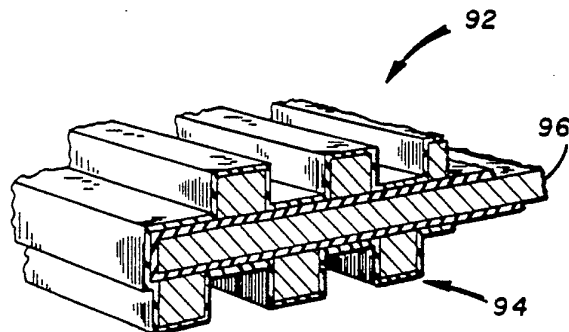

FIG. 9

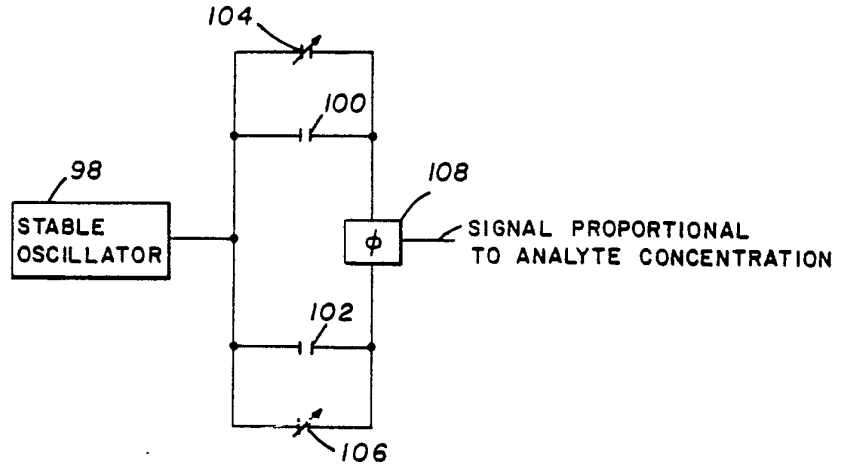

FIG. 10

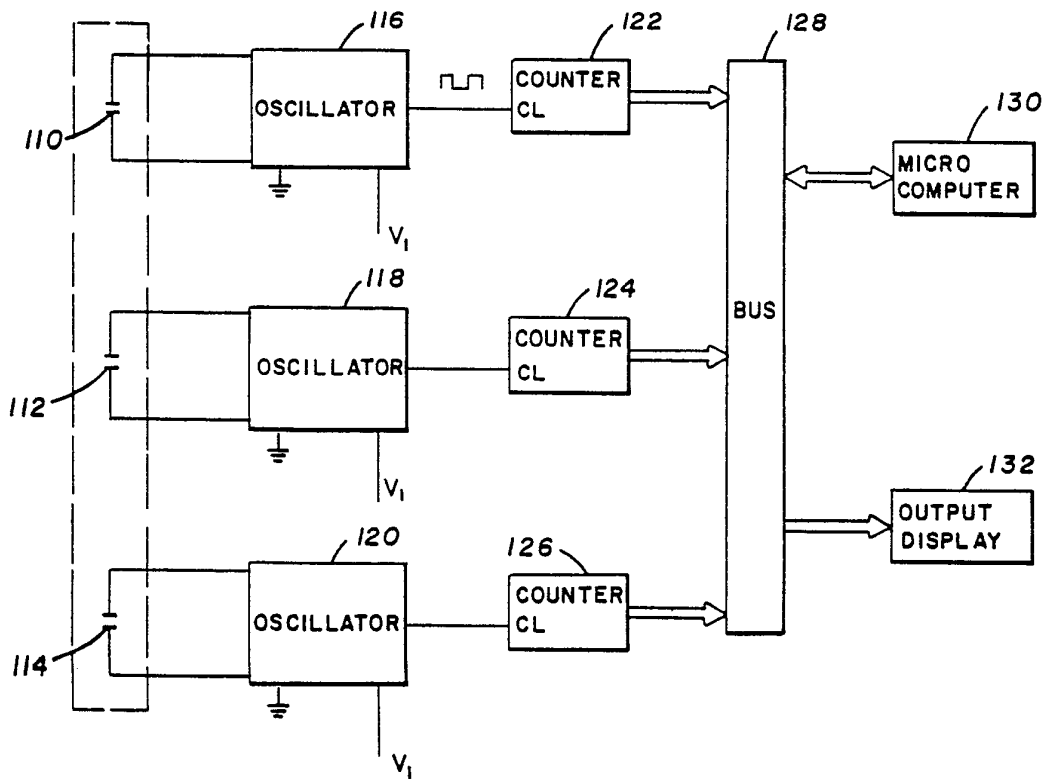
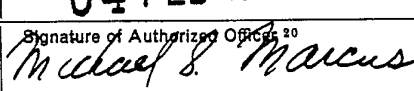

FIG. 11

INTERNATIONAL SEARCH REPORT

International Application No PCT/US86/02433

I. CLASSIFICATION OF SUBJECT MATTER (if several classification symbols apply, indicate all) ³		
According to International Patent Classification (IPC) or to both National Classification and IPC IPC (4): G01N 33/566; G01N 33/545; G01N 27/22 US Cl. 422/68, 90, 98; 435/5, 7, 817; 436/501, 531, 805, 806, 807		
II. FIELDS SEARCHED		
Minimum Documentation Searched ⁴		
Classification System	Classification Symbols	
U.S.	324/6R, 61C, 71.1; 436/150, 528, 531, 805, 806, 827, 422/68, 83, 90, 98; 435/5, 7, 817; 436/501	
Documentation Searched other than Minimum Documentation to the Extent that such Documents are Included in the Fields Searched ⁵		
III. DOCUMENTS CONSIDERED TO BE RELEVANT ¹⁴		
Category *	Citation of Document, ¹⁶ with indication, where appropriate, of the relevant passages ¹⁷	Relevant to Claim No. ¹⁸
X	US, A, 4,453,126 (VOLGYESI) 05 June 1984 See entire document.	1-8, 13-22 29-32, 34, 41, 44, 49- 59, 67-72, 75, 76
Y	M. Brewer et al, "Concise Encyclopedia of Biochemistry", published 1983 by deGruyter; see page 251 'Lipids'.	1-98
Y	GB, A, 2,137,361 (RAYMOND), 03 October 1984. See entire document.	1-98
Y	US, A, 4,334,880 (MALMROS) 15 June 1982. See entire document.	1-98
Y	US, A, 4,350,660 (ROBINSON) 21 September 1982 See entire document.	1-98
Y	US, A, 4,233,402 (MAGGIO) 11 November 1980. See entire document.	1-98
Y	US, A, 3,999,122 (WINSTEL) 21 December 1976. See entire document.	1-98
<p>* Special categories of cited documents: ¹⁵</p> <p>"A" document defining the general state of the art which is not considered to be of particular relevance</p> <p>"E" earlier document but published on or after the international filing date</p> <p>"L" document which may throw doubts on priority claim(s) or which is cited to establish the publication date of another citation or other special reason (as specified)</p> <p>"O" document referring to an oral disclosure, use, exhibition or other means</p> <p>"P" document published prior to the international filing date but later than the priority date claimed</p> <p>"T" later document published after the international filing date or priority date and not in conflict with the application but cited to understand the principle or theory underlying the invention</p> <p>"X" document of particular relevance; the claimed invention cannot be considered novel or cannot be considered to involve an inventive step</p> <p>"Y" document of particular relevance; the claimed invention cannot be considered to involve an inventive step when the document is combined with one or more other such documents, such combination being obvious to a person skilled in the art.</p> <p>"&" document member of the same patent family</p>		
IV. CERTIFICATION		
Date of the Actual Completion of the International Search ²	Date of Mailing of this International Search Report ²	
30 January 1987	04 FEB 1987	
International Searching Authority ¹	Signature of Authorized Officer ²⁰	
ISA/US	 MICHAEL S. MARCUS	