

Sept. 18, 1962

R. E. MAYNARD

3,054,501

LUNCH BOX

Filed Aug. 5, 1960

2 Sheets-Sheet 1

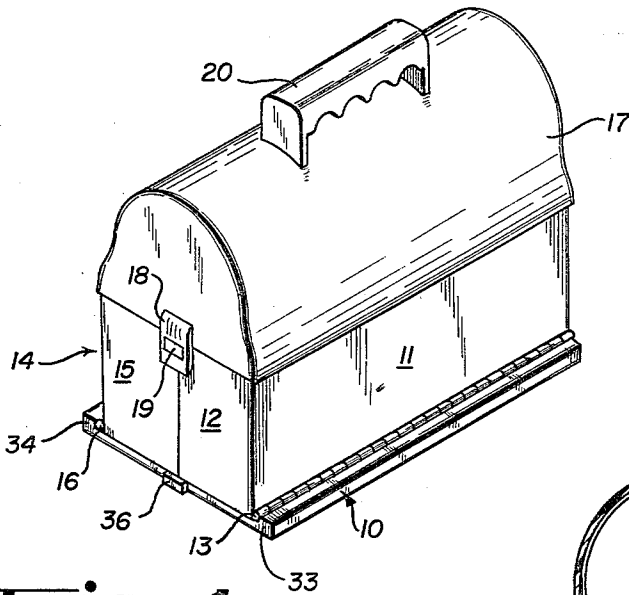

Fig. -1

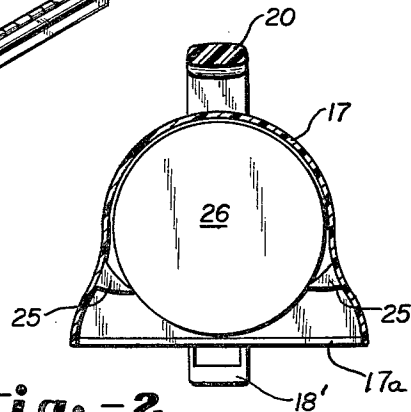

Fig. -2

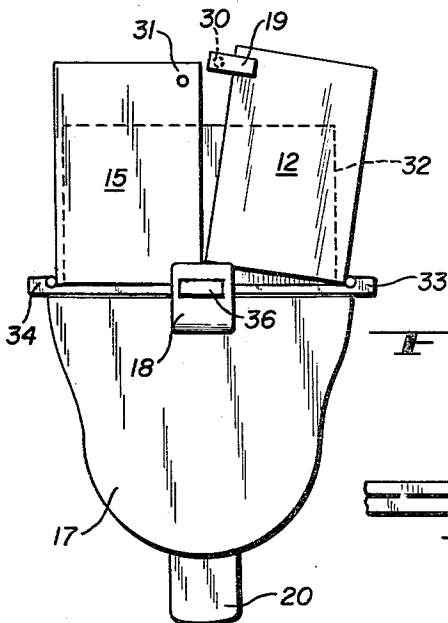

Fig. -3

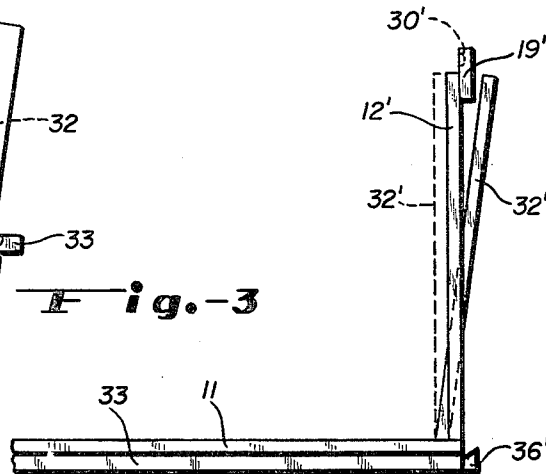

Fig. -4

INVENTOR.
Robert E. Maynard
BY
McDrew & Edwards

ATTORNEYS

Sept. 18, 1962

R. E. MAYNARD

3,054,501

LUNCH BOX

Filed Aug. 5, 1960

2 Sheets-Sheet 2

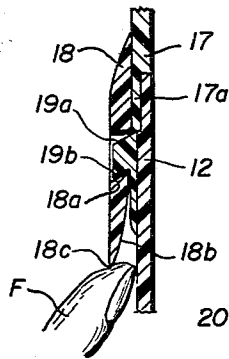

Fig. 6

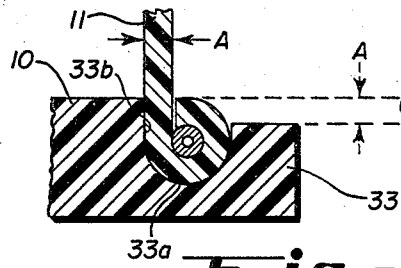

Fig. 7

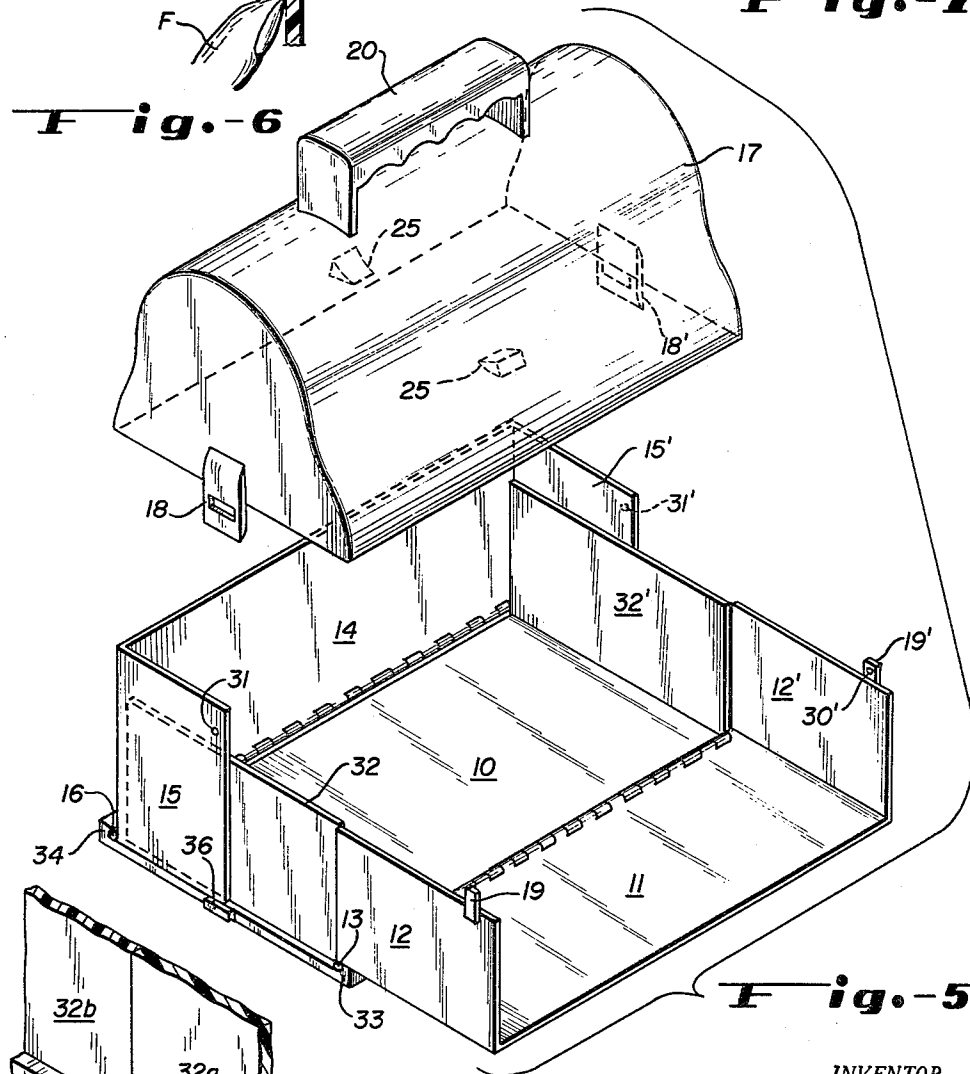

Fig. 5

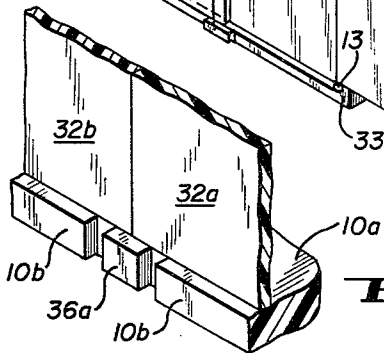

Fig. 8

INVENTOR.
Robert E. Maynard

BY *W. R. Edwards*

ATTORNEYS

1

3,054,501

LUNCH BOX

Robert E. Maynard, 1815 Beekman Place, Denver, Colo.

Filed Aug. 5, 1960, Ser. No. 47,677

12 Claims. (Cl. 206-4)

This invention is directed to a durable, lightweight combination lunch box and luncheon tray.

Briefly, in carrying out the objects of my invention, in one embodiment, a group of durable, lightweight, preferably plastic sections are constructed and arranged to be easily manipulated to form a lunch box of a generally elongated rectangular configuration having releasably secured thereto a dome-shaped cover portion which in turn is adapted to releasably secure a vacuum bottle or the like therein. By further manipulation of the same parts, the lunch box is adapted to be formed into a sturdy luncheon tray having integral upstanding sides to prevent spilling of articles contained thereon; and the cover portion is adapted to be manipulated to form a support or stand which may be gripped between the knees of a user.

It is thus among the features and advantages of my invention to provide a lightweight, durable, easily manufactured and inexpensive combination lunch box and tray which is adapted to be made in many colors to satisfy varying tastes. Further features will become obvious to those skilled in the art from the hereafter set forth detailed description of the appended exemplary drawings. In these drawings:

FIG. 1 is an isometric view of a lunch box embodying my invention;

FIG. 2 is an end view in partial section of the dome shaped cover portion of the lunch box of FIG. 1;

FIG. 3 is an end view of the bottom portion of the lunch box of FIG. 1;

FIG. 4 is an enlarged fragmentary detail side view of a portion of the elements of FIG. 3 when in their open or tray position;

FIG. 5 is an enlarged isometric exploded view of the lunch box of FIG. 1 in a stage of its manipulation to form a lunch tray;

FIG. 6 is an enlarged detail of latching means usable with my invention;

FIG. 7 is an enlarged fragmentary detail of the hinge arrangement; and

FIG. 8 is an enlarged fragmentary isometric view of an alternative arrangement of parts.

Before describing the drawings in detail, I wish it understood that they are merely exemplary of one manner of practicing my invention and I do not desire to be limited thereby, and I intend the appended claims to cover all modifications within the spirit and scope of my invention.

The lunch box is comprised essentially of an enlarged generally rectangular planar base portion 10 pivotally carrying sides 11 and 14. The sides have integral extensions 12 and 12' and 15 and 15', respectively, each forming substantially one-half of an end and are adapted to be pivotally moved from their upright configuration as shown in FIG. 1 around the hinges 13 and 16 to a horizontal, tray forming position, as will be described hereafter.

The dome shaped upper portion 17 is removably held in latched association with the bottom portion by interaction between latches 18 and 18' and the lugs 19 and 19'. A handle 20 is integrally attached to the top of the cover 17 to facilitate carrying. On the inside of the top portion 17 are a plurality of downwardly and inwardly extending resilient ears 25 which are adapted to releasably secure a vacuum bottle 26 on the like thereabove.

2

When it is desired to remove the top portion 17, the latch portions 18 and 18' (see FIG. 5) on the cover 17 are manually moved to allow disengagement from lugs 19 and 19'. The lugs 19 and 19' are preferably of a generally rectangular configuration and are integrally attached to the side extensions 12 and 12' near the upper edge thereof. On the internal surface of the lugs 19 and 19', beyond the edge of extensions 12 and 12' are depressions 30 and 30'. These depressions are adapted to be held in locking engagement with bumps or protuberances 31 and 31' on extensions 15 and 15'. The lugs (FIG. 6) preferably have a sloping upper surface 19a and a hook-shaped lower surface 19b. The depth of the hook in the surface 19b is of such dimension as to engage the sloping surface 18a of the latch 18. The lower edge 18b of the latch is outwardly biased to the extension 18c. To release the latches, the user need only insert a finger F under the extension and apply an outwardly directed lifting pressure. The ends of the cover, such as 17a in FIG. 6, are recessed to receive the upper edge of the end 12 when in the closed lunch box arrangement.

Integrally attached to the planar base 10 are upstanding end portions 32 and 32'. When the sides 11 and 14 are pivoted around their respective hinges 13 and 16, they are supported in a substantially horizontal configuration, parallel to and in a plane substantially coincident with that of the base 10, by the base extensions 33 and 34, respectively, acting as stops to prevent further rotation about the hinges. The upstanding end portions 32 and 32' are mounted adjacent the interior surface of the extensions 12 and 15 and 12' and 15', respectively. These end portions have an upwardly, outwardly sloping configuration when in the tray forming position. Thus, when the sides are in their upright lunch box forming position, the ends, such as end 32' in FIG. 4, are deformed or biased and held in the substantially vertical configuration shown in dotted lines. When the sides 13 and 14 with the respective extension portions 12 and 12' and 15 and 15' are moved to the horizontal position, the same ends 32 and 32', are released from their biased position and snap out to lock the respective sides. The amount of outward deformation or bias of the end 32' has been suggested in FIG. 4, for purposes of illustration; in practice, it is not necessary to provide more bias than required to act as a stop or detent to prevent pivotal movement of the side 11. Preferably, the vertical height of ends 32 and 32' is substantially equal to the width of the extensions to thereby form a tray wall of substantially uniform height. The respective opposite ends of the planar base portion 10 carry lugs 36 and 36', respectively, which are substantially identical in dimension and configuration to the lugs 19 and 19' carried on the extensions 12 and 12'.

While the foregoing description with reference to FIG. 4 has been relative to one side and end of the lunch box, reference to FIG. 5 makes it clear that each end has a similar configuration.

The top surface of the extension portion 33 is in a plane parallel to but slightly lower than the plane of the top surface of the base member 10 (FIG. 7). The vertical height between those surfaces is indicated by A and is equal to the thickness of a side wall. The hinge 13 seats in the cylindrical groove 33a and the lower end portion of a side wall, such as side wall 11, is in a flush sealing arrangement with the vertical wall 33b. With the foregoing arrangement, when a wall, such as wall 11, is moved to its horizontal tray forming position, it forms a smooth tray surface.

It is anticipated that other arrangements for the biased members 32 and 32' may be used. Such an alternative

arrangement is shown in FIG. 8 wherein each of the biased members is split so as to form two separate sections 32a and 32b. With this arrangement each of the side members 11 and 14 will be individually locked by the biased sections 32a and 32b, respectively, as the said sides reach the horizontal tray forming position.

FIG. 8 is also indicative of an alternative arrangement for the locking lugs on the base member 10a. In this arrangement, each end has an extending ledge 10b. This ledge is vertically channeled to form a lug 36a. The lug 36a is also indicative of an alternative lug configuration usable within my inventive concepts. In any case, the vertical channels are of sufficient dimension to accommodate a complementary latch opening.

In operation, therefore, when it is desired to form the lunch box, the latches 18 and 18' are moved from engagement with the lugs 19 and 19' and the dome shaped cover is lifted from the rectangular bottom. The locking devices 19 and 19' are then moved from engagement with the bumps or protuberances 31 and 31', and the sides 11 and 14 pivotally moved to a substantially horizontal configuration parallel to the plane of the base member 10. Substantially coincident therewith, the ends 32 and 32' snap out from their biased or deformed configuration to lock the sides 11 and 14 in position. Thereafter the vacuum bottle 26 may be snapped out of engagement with the ears 25. The top 17 may then be inverted and the latches 18 and 18' placed in engagement with the lugs 36 and 36'. The so inverted cover may then be grasped between the knees of a user, to hold the tray firmly while in use. Of course, if it is desired to use the tray on an available surface, such attachment is not necessary.

After use, the sides 32 and 32' are pressed inwardly to allow the sides 11 and 14 to be pivotally moved to their upright position. In the upright position of the sides 11 and 14, the lugs 19 and 19' engage the bumps 31 and 31' to form the elongated substantially rectangular open top box or bottom portion. Thereafter, the vacuum bottle 26 is inserted into the upper portion 17 where it is held in position by the ears 25.

One novel locking arrangement within my inventive concepts would be to provide identical side portions which could be made from the same die. In such an arrangement (not shown) the lug 19 would be on the side 12 and the lug 19' on the side 15'. The protuberances 30 and 30' would be on sides 15 and 15', respectively.

The cover portion 17 is then placed over the bottom portion and the latches 18 and 18' moved into engagement with the lugs 19 and 19'. Preferably, the upper portion 17, when in the lunch box configuration, will encompass the upper peripheral edges of the bottom portion thereby assuring additional strength and providing an effective seal to protect the items stored in the lunch box.

It is to be understood that other locking devices than those shown could be used, and such would be within my inventive concept. However, such other locking devices should have the characteristics and functions and interact in a manner substantially similar to that of my exemplary embodiment.

Having thus described my invention, what I desire to have protected by Letters Patent is set forth in the following claims.

What is claimed is:

1. A lunch box comprising a box-like bottom portion having an open top and a closed bottom, a dome-shaped cover portion adapted to be releasably secured over the said open top and encompass the upper peripheral edges thereof, the opposite sides of said bottom portion being pivotally mounted on said closed bottom and constructed and arranged to be moved from a box forming upright configuration to a substantially horizontal luncheon tray configuration, and means on said bottom adapted to lock the sides in said substantially horizontal configuration.

2. A lunch box comprising a box-like bottom portion

having an open top and a closed bottom, a cover portion adapted to be releasably secured over the said open top and encompass the upper peripheral edges thereof, the opposite sides of said bottom portion being pivotally mounted on said closed bottom and constructed and arranged to be moved from a box forming upright configuration to a substantially horizontal luncheon tray configuration, and said bottom having at least one outwardly biased end member constructed and arranged to move to a locking position substantially as said sides are moved to the horizontal configuration to thereby prevent relative movement between said sides and said bottom.

3. A lunch box comprising a planar bottom member, a pair of opposed side portions pivotally interconnected substantially along their lower edges to said bottom member, said side members having extension portions adjacent opposite vertical edges constructed and arranged to form the ends of the lunch box, complementary locking means on said extensions, outwardly biased members mounted on said bottom member adjacent the interior surfaces of said extensions when in a box forming configuration, said outwardly biased members arranged to bear against the interior surface of said extension portions to frictionally engage the said extensions when in said box forming configuration, a cover portion inclusive of latch means constructed and arranged to be releasably secured by the said complementary locking means on the extension portions, substantially identical locking means on opposite ends of said bottom member constructed and arranged to selectively secure the said cover portion as a support.

4. The box of claim 3 in which the opposite side portions are spaced inwardly from the edges of the bottom member whereby said bottom member supports the side members in a substantially horizontal configuration parallel with said base member when they are moved to form a luncheon tray.

5. The box of claim 3 in which the width of the extension portions and the height of the said biased members are substantially the same whereby to form walls of uniform height for said luncheon tray.

6. The box of claim 3 in which the outwardly biased members are constructed and arranged to move to a locking position when the sides are moved to the said horizontal position.

7. The box of claim 3 in which a plurality of downwardly and inwardly extending integral resilient ears are mounted on the interior surface of the cover portion and constructed and arranged to releasably secure a vacuum bottle or the like therein.

8. A lunch box comprising a planar bottom member, a pair of opposed side portions hingedly interconnected substantially along their lower edges to said bottom member, said bottom member having portions extending laterally beyond the hinges of said hinged portions and positioned to engage and act as stops for the side portions when rotated about the said hinges to a horizontal position, said side members having extension portions adjacent opposite vertical edges constructed and arranged to form the ends of the lunch box, complementary locking means on said extension portions of said side members, outwardly biased members mounted on said bottom member adjacent the interior surfaces of said extensions when in a box forming configuration, said outwardly biased members arranged to bear against the interior surface of said extension portions to frictionally engage the said extension portions when in said box forming configuration, a cover portion inclusive of latch means constructed and arranged to be releasably secured by the said complementary locking means on the extension portions, substantially identical locking means on opposite ends of said bottom member constructed and arranged to selectively secure the said cover portion as a support.

9. A lunch box comprising a planar bottom mem-

5

6

ber, a pair of opposed side portions hingedly interconnected substantially along their lower edges to said bottom member, said bottom member having portions extending laterally beyond the hinges of said hinged portions and positioned to engage and act as stops for the side portions when rotated about the said hinges to a horizontal position, said side members having extension portions adjacent opposite vertical edges constructed and arranged to form the ends of the lunch box, complementary locking means on said extensions, at least one outwardly biased member mounted on said bottom member adjacent the interior surfaces of adjacent ones of said extensions when in a box forming configuration, said outwardly biased member arranged to bear against the interior surface of said adjacent ones of said extension portions to frictionally engage the said adjacent extensions when in said box forming configuration and to snap out and lock the extensions when both of them are in the said horizontal position, a cover portion inclusive of latch means constructed and arranged to be releasably secured by the said complementary locking means on the extension portions, substantially identical locking means on opposite ends of said bottom member constructed and arranged to selectively secure the said cover portion as a support.

10. A container comprising a bottom wall and a pair of opposed side walls, at least one of said side walls being pivotally connected to said bottom wall along its lower edge and being movable from a container closing position to a horizontal tray forming position, each pivotally connected side wall having extensions adjacent its opposite ends providing end wall portions for said container, means for holding each said pivotally connected wall in its container forming position, at least one upwardly extending wall member mounted on said bottom wall near an end thereof and having a width substantially equal to the distance between said side walls, said upwardly extending wall member having a portion positioned adjacent and in frictional engagement with a respective adjacent one of said extensions when in said container forming position, and means on said bottom wall for preventing movement of each said pivotally connected side wall beyond its horizontal tray forming position, said portion of said upwardly extending wall member and said respective one of said extensions being biased with respect to one another into face engagement in said container forming position and moving relatively to one another into locking position substantially as said respective pivotally connected side wall reaches its horizontal tray forming position.

11. A container comprising a bottom wall, a pair of opposed side walls pivotally connected substantially along their lower edges to said bottom wall and movable between an upright container forming position and a horizontal tray forming position, said side walls having

extensions adjacent opposite ends constructed and arranged to form the ends of said container, means for holding said extensions in their container forming position, at least one upwardly extending member mounted on said bottom wall near one of the ends thereof and having portions in juxtaposition with adjacent ones of said extensions when in said container forming position, said portions of said upwardly extending member and the adjacent ones of said extensions being biased toward one another in frictional engagement when in said container forming position, and means for preventing movement of said side walls beyond their horizontal tray forming position, each said portion of said upwardly extending member and the respective adjacent one of said extensions being arranged to move with respect to one another into a locking position substantially as said side walls are moved to their horizontal tray forming position wherein said upwardly extending member abuts the adjacent edges of the respective ones of said extensions and prevents return movement of said side walls.

12. A container comprising a bottom wall, a pair of opposed side walls pivotally connected substantially along their lower edges to said bottom wall and movable between an upright container forming position and a horizontal tray forming position, said side walls having extensions adjacent opposite ends constructed and arranged to form the ends of said container, complementary locking means on said extensions for holding them in their container forming position, at least one upwardly extending wall member mounted on said bottom wall near a respective end thereof and having a width substantially equal to the distance between said side walls, said upwardly extending wall member having portions positioned adjacent and in engagement with the interior surfaces of the adjacent ones of said extensions when in said container forming position, said portions of said upwardly extending member being arranged to bear against the respective surfaces of said adjacent extensions to frictionally engage them when in said container forming position, and means for preventing movement of said side walls beyond their horizontal tray forming position, said portions of said upwardly extending wall member and said adjacent extensions being arranged to move relatively to one another into a locking position substantially as said side walls are moved to their horizontal tray forming positions wherein said member abuts the adjacent edges of said adjacent extensions and prevents return movement of said side walls.

References Cited in the file of this patent

UNITED STATES PATENTS

320,814	Pollard	June 23, 1885
1,093,110	Christopher	Apr. 14, 1914
1,182,244	Bierwirth	May 9, 1916
2,923,400	Craig	Feb. 2, 1960