



Europäisches Patentamt  
European Patent Office  
Office européen des brevets



Publication number: **0 429 226 B1**

12

## EUROPEAN PATENT SPECIFICATION

- 49 Date of publication of patent specification: **17.08.94** 51 Int. Cl.<sup>5</sup>: **E05B 21/00**
- 21 Application number: **90312256.2**
- 22 Date of filing: **09.11.90**

54 **Lever locks.**

30 Priority: **24.11.89 GB 8926637**

43 Date of publication of application:  
**29.05.91 Bulletin 91/22**

45 Publication of the grant of the patent:  
**17.08.94 Bulletin 94/33**

84 Designated Contracting States:  
**CH DE LI SE**

56 References cited:  
**EP-A- 0 096 513**  
**EP-A- 0 297 063**  
**GB-A- 374 571**  
**GB-A- 2 153 425**

73 Proprietor: **CHUBB RESEARCH LIMITED**  
**Chubb House**  
**Staines Road West**  
**Sunbury-on-Thames Middlesex TW16 7AR**  
**(GB)**

72 Inventor: **Johns-Hunt, John**  
**25 Dumbleberry Avenue,**  
**Sedgley**  
**Dudley, Worcestershire (GB)**  
Inventor: **Robinson, William Keith**  
**Brook Cottage,**  
**Brewood Road,**  
**Lower Green,**  
**Coven**  
**Wolverhampton, West Midlands (GB)**

74 Representative: **Obee, Robert William**  
**Group Patents Department**  
**Racal Group Services Limited**  
**Richmond Court**  
**309 Fleet Road**  
**Fleet Hampshire GU13 8BU (GB)**

**EP 0 429 226 B1**

Note: Within nine months from the publication of the mention of the grant of the European patent, any person may give notice to the European Patent Office of opposition to the European patent granted. Notice of opposition shall be filed in a written reasoned statement. It shall not be deemed to have been filed until the opposition fee has been paid (Art. 99(1) European patent convention).

## Description

The present invention relates to lever locks.

By the term "lever locks" we mean key locks of the well-known kind in which the key-recognition mechanism comprises a plurality of pivoted or slidable tumblers or retainers (termed "levers") each having a surface, usually of arcuate form, (termed the "belly") which is swept by a respective step of a bitted key when the latter is turned in the lock, whereby to shift the levers to selected relative positions in which they collectively permit retraction of the bolt or other such locking member from its locking to its unlocking position. In high security locks of this kind the belly shape is common to all of the levers so that the corresponding key bit pattern cannot be surreptitiously derived simply by inspection of the shape of the bellies through the keyhole. Even so, in known locks it may be possible to derive some useful information on the shape of the key by studying the pattern of wear on the lever bellies caused by repeated usage of the key, e.g. with the aid of an endoscope inserted through the keyhole. This is because the actual length of the path swept on each belly is related to the height of the corresponding step on the key bit. Conventional means - such as so-called drill pins and barrel-and-curtain members - aimed at restricting unauthorised access to the levers with any form of tool offer some defence against attempts to read the key code in this way but may not be completely effective. In particular the barrel member which turns with the key has a longitudinal slot of a width sufficient only to accommodate the bit of the key and is normally held by a spring detent in the key-entry position in which it masks the lever bellies from any form of inspection. Nevertheless, with appropriate tools and skill it may be possible to manipulate this member to positions in which its slot faces the regions of the bellies swept by the key, and thereby to read the wear pattern through the slot.

One solution to this potential problem is put forward in United Kingdom patent specification no. 1605277. In accordance with that proposal the belly portions of the levers are effectively truncated so that their lengths of arc are all no longer than the length which will be swept by the lowest-lift key step. In other words the whole of each belly will always be swept by the key so that their resulting wear patterns should all be equivalent. A consequence is that for higher-lift key steps the initial (and final) point of contact with the respective lever is along the side edge of the key bit rather than at its tip. In reality the geometrical constraints of the lever system mean that this proposal is difficult to implement and limits undesirably the number of different lifts with which it can be used. More

particularly, while it is readily possible to arrange that one end of the respective swept paths on the lever bellies will occur at an equivalent point on each lever, it cannot be arranged likewise for the other ends of the paths if sufficient differs are to be provided.

The present invention seeks to provide an improved solution to the potential threat of reading lever wear patterns in a lever lock of the kind where at least one end of the respective paths swept by the key on the lever bellies occurs at different points on different levers and accordingly proposes a lock according to the first part of claim 1 including i.a. a barrel member to turn with the correct key and having a longitudinal slot to accommodate the key bit, which comprises an arrester member which in one position blocks the barrel member from being turned to the extent which would enable its slot to face a region of the lever bellies wherein said different points are located, said arrester member being linked to the bolt or other such locking member such as to prevent displacement of the arrester member from said one position in the locking condition of the locking member but the arrester member being displaceable from said one position by movement of the correct key when the latter is turned to move the locking member to its unlocking condition.

These and other features of the present invention will now be more particularly described, by way of example, with reference to the accompanying drawings, in which:

Figure 1 is a view of the mechanism of one embodiment of a lever lock made in accordance with the invention, with its cap removed, in the normal locking condition;

Figure 2 is a side view of the bolt of the lock of Figure 1;

Figure 3 is a side view, partially in section, of the barrel-and-curtain member of the lock of Figure 1;

Figure 4 is a view similar to Figure 1 showing the lock mechanism when an attempt is made to turn the barrel-and-curtain member without the correct key; and

Figure 5 is a view similar to Figures 1 and 2 showing the lock mechanism during unlocking with the correct key.

With reference to Figure 1, the illustrated lock has a casing 1 from which is extended and retracted the head 2 of a bolt 3. The plate-like tail 4 of the bolt has the usual talons or drive surfaces 4A,4B (Figure 2) for engagement with the bolt step of the key bit when the latter is turned in the appropriate sense to extend or retract the bolt. In the illustrated locking condition of the bolt, it is blocked from retraction by a pack of levers 5 (of which only the nearest one is seen in Figure 1)

lying in the path of the bolt stump 6. The levers are pivoted on a pin 7 and biased in the anticlockwise sense (as viewed) to their locking positions by leaf springs 8. Each lever has a gate 9 in its leading edge, however, which can pass the stump 6 to permit retraction of the bolt when the levers are set to their unlocking positions by turning the correct key. In this respect it will be understood that the gates 9 in different levers will be located at different heights and the levers will all be lifted through the correct distances to align their gates with the stump 6 when the respective steps on the correct key bit sweep their bellies 10. Since different levers must be lifted through different distances it follows that the lengths of the paths swept on different lever bellies by the respective key steps will also differ.

The lock also includes a barrel-and-curtain member 11 (see also Figure 3) borne for rotation transversely to the line of movement of the bolt and defining the turning axis for the key. The barrel part 12 has a longitudinal slot 13 of a width sufficient only to accommodate the bit of the key and in the normal locking condition of the lock is aligned as shown in Figure 1, to register with the leg portion of the corresponding keyhole in the cap (not shown) which closes the proximal side of the casing 1. It will be appreciated that in this position the barrel 12 masks the lever bellies 10 from any form of inspection by means of a tool inserted through the keyhole and into the barrel. The curtain part 14 is in the form of a disc at the proximal end of the barrel 12, immediately behind the keyhole, and has a slot 15 to pass the key bit when in register with the keyhole. This curtain will block access through the leg portion of the keyhole, however, whenever it is turned away from the illustrated position. Although not shown, there may also be a fixed drill pin extending from the rear of the casing 1 axially through the centre of the barrel 12, the end of the key shank then being of pipe form.

As thus far described, the lock is of generally conventional form. The barrel-and-curtain member 11 (and drill pin if provided) make it difficult for any surreptitious sight to be had of the lever bellies 10 by use of an inspection tool inserted through the keyhole, in an attempt to read the pattern of wear which is imparted to the levers by repeated usage of the key. They do not of themselves, however, preclude the possibility that the barrel might be turned by a suitable implement (other than the correct key) to face its slot 13 towards the lever bellies and thus permit such inspection. In this regard, the levers 5 are assumed to be configured such that the key bit will engage with or disengage from each belly (in accordance with its direction of turning) at an equivalent point on each lever at that end of the swept path which is at the leading end

of the belly (i.e. towards the stump 6) but that the key bit will engage with/disengage from each belly at a different point on each lever at that end of the swept path which is at the trailing end of the belly (i.e. towards the pin 7). Accordingly, it is the trailing ends of the bellies which represent the vital region of which inspection must be made if information on the key code is to be derived from the lever wear pattern.

In order to avoid surreptitious turning of the barrel 12 to the extent sufficient to enable inspection of the trailing ends of the bellies 10 an additional arrester member 16 is provided. This arrester is in the form of a plate located to the side of the pack of levers 5, in the same plane as the curtain 14. It is borne for limited sliding movement parallel to the bolt 3 by means of two slots 17, 18 engaging respectively over the pin 7 and over a pin 19 mounted on the bolt. In the locking condition of Figure 1, however, the arrester 16 is prevented from displacement to the right (as viewed) by the presence of the pin 19 at one end of the slot 18. It will also be seen that the curtain 14 in this lock is formed with a lug defining abutments 20 and 21 at each end. In the condition of Figure 1 the abutment 20 lies against an abutment 22 on the arrester and thereby blocks turning of the barrel-and-curtain member 11 in the anti-clockwise sense (as viewed). Furthermore, and as shown in Figure 4, clockwise turning of the barrel-and-curtain member from this condition will be restricted by an abutment 23 on the arrester blocking the abutment 21. Consequently, by these means the barrel slot 13 is prevented from being turned to face the trailing ends of the lever bellies 10 while the bolt 3 is in its locking condition.

Clearly, the arrester 16 must not interfere with the normal locking and unlocking movements of the bolt. To retract the bolt from the Figure 1 condition the correct key is inserted and given a complete turn in the clockwise sense. This firstly results in the key bit engaging the lever bellies 10 and lifting the levers to align their gates 9 with the bolt stump 6. Immediately thereafter the bolt step on the key bit engages the appropriate talon 4B to begin the retracting movement of the bolt. This all occurs in the arc of movement of the key prior to the point at which the curtain abutment 21 meets the abutment 23 of the arrester, the latter condition being shown in Figure 5. The coupling of the pin 19 in the slot 18 provides sufficient lost motion between the bolt 3 and arrester 16 to allow the arrester now to be shifted to the right by the abutment 21 as the key 24 completes its revolution. The mechanism finishes with the bolt 3 withdrawn and the levers 5 returned to their locking positions to trap the stump 6 in their pockets 9A, the barrel-and-curtain member 11 in its Figure 1

position and the arrester 16 also withdrawn so that an abutment 25 on the arrester now lies against the curtain abutment 21. The linear distance through which the bolt is retracted exceeds that through which the arrester is moved and hence in the unlocking condition the pin 19 on the bolt now lies at the right hand end (as viewed) of the arrester slot 18. Consequently, in this condition the arrester is blocked from any movement to the left and there is therefore no risk that it might be shaken or otherwise displaced so as to block with its abutment 22 subsequent anti-clockwise movement of the barrel-and-curtain member 11.

To extend the bolt once more the correct key is inserted and given a complete turn in the anti-clockwise sense. This returns the mechanism to the Figure 1 condition, the arrester 16 being pulled to the left by the bolt pin 19 during the latter part of the bolt extension and after the curtain abutment 21 has cleared the arrester abutment 23.

### Claims

1. A key lock in which the key-recognition mechanism comprises a plurality of levers (5) each having a belly (10) which is swept by a respective step of a bitted key (24) when the latter is turned in the lock, whereby to shift the levers (5) to selected relative positions in which they collectively permit retraction of the bolt (3) or other such locking member from its locking to its unlocking position, at least one end of the respective paths swept by the key (24) on the lever bellies (10) occurring at different points on different levers (5); comprising a barrel member (12) to turn with the correct key (24) and having a longitudinal slot (13) to accommodate the key bit; and characterised by an arrester member (16) which in one position blocks the barrel members (12) from being turned to the extent which would enable its slot (17) to face a region of the lever bellies (10) wherein said different points are located, said arrester member (16) being linked (18/19) to the locking member (3) such as to prevent displacement of the arrester member (16) from said one position in the locking condition of the locking member (3) about the arrester member (16) being displaceable from said one position by movement of the correct key (24) when the latter is turned to move the locking member (3) to its unlocking condition.
2. A lock according to claim 1 wherein said barrel member (12) is comprised in a barrel-and-curtain member (11) the curtain portion (14) of which abuts (20/21) the arrester member (16) to block the barrel member (12) from being

turned as aforesaid when the arrester member (16) is in its said one position.

3. A lock according to claim 2 wherein the arrester member (16) is borne for sliding movement in parallel with the locking member (3) and the linkage (18/19) of the arrester member (16) to the locking member (3) provides for lost motion therebetween whereby movement of the locking member in either sense between its locking and unlocking positions leads the parallel movement of the arrester member (16).
4. A lock according to claim 3 wherein movement of the arrester member (16) away from its said one position occurs through abutment (21) of said curtain portion (14) with the arrester member (16) after commencement of the movement of the locking member (3) towards its unlocking position when the correct key (24) is turned in the unlocking sense, and return movement of the arrester (16) member to its said one position occurs through the linkage (18/19) of the arrester member (16) to the locking member (3) during the latter part of the movement of the locking member (3) towards its locking position when the correct key (24) is turned in the locking sense.

### Patentansprüche

1. Schlüsselbetätigtes Schloß, bei welchem der Schlüsselerkennungsmechanismus eine Vielzahl von Hebeln (5) umfaßt, von denen jeder einen Bauch (10) aufweist, welcher durch eine entsprechende Stufe eines gerasteten Schlüssels (24) überstrichen wird, wenn dieser in dem Schloß gedreht wird, wodurch die Hebel (5) in bestimmte Relativstellungen verschoben werden, in welchen sie gemeinsam die Zurückziehung des Bolzens (3) oder eines anderen Verschußbauteils von seiner Verriegelungs- in seine Öffnungsstellung ermöglichen, wobei mindestens ein Ende der von dem Schlüssel (24) überstrichenen Wege auf den Hebelbäuchen (10) bei verschiedenen Hebeln (5) an verschiedenen Punkten auftritt; umfassend ein Zylinderteil (12) zur Drehung mit dem korrekten Schlüssel (24) und mit einem Längsschlitz (13) zur Aufnahme der Schlüsselraste; **gekennzeichnet durch** ein Arretierteil (16), welches in einer Stellung das Zylinderteil (12) dagegen blockiert, sich so weit zu drehen, daß sein Schlitz (17) einem Bereich auf den Hebelbäuchen (10) gegenübersteht, auf welchem sich die verschiedenen Punkte befinden, wobei das Arretierteil (16) an dem Verschußteil (3)

- befestigt (18/19) ist, um eine Verschiebung des Arretierteils (16) von dieser einen Stellung in den Verriegelungszustand des Verschließteils (3) zu verhindern, das Arretierteil (16) jedoch durch Bewegung des korrekten Schlüssels (24) aus dieser einen Stellung verschiebbar ist, wenn dieser zur Bewegung des Verschließteils (3) in seinen Öffnungszustand gedreht wird. 5
2. Schloß nach Anspruch 1, wobei das Zylinderteil (12) zu einem Zylinderabdeckteil (11) gehört, dessen Abdeckteil (14) auf dem Arretierteil (16) anschlägt (20/21) und hierdurch das Zylinderteil (12) wie oben beschrieben an der Drehung hindert, wenn das Arretierteil (16) sich in der genannten einen Stellung befindet. 10 15
3. Schloß nach Anspruch 2, wobei das Arretierteil (16) geeignet gelagert ist, um sich gleitend parallel zu dem Verschließteil (3) zu bewegen und die Verbindung (18/19) des Arretierteils (16) mit dem Verschließteil (3) eine gegenseitige Bewegung zwischen beiden verhindert, während eine Bewegung des Verschließteils in beiden Richtungen zwischen Verriegelungs- und Öffnungsstellung zu einer parallelen Bewegung des Arretierteils (16) führt. 20 25
4. Schloß nach Anspruch 3, wobei die Bewegung des Arretierteils (16) von seiner einen Stellung weg durch Anschlag (21) des Abdeckteils (14) auf das Arretierteil (16) erfolgt nach Beginn der Bewegung des Verschließteils (3) zu seiner Öffnungsstellung, wenn der korrekte Schlüssel (24) in Öffnungsrichtung gedreht wird und die Zurückbewegung des Arretierteils (16) in seine eine Stellung durch die Verbindung (18/19) des Arretierteils (16) mit dem Verschließteil (3) während des letzten Teils der Bewegung des Verschließteils (3) zu seiner Verriegelungsstellung erfolgt, wenn der korrekte Schlüssel (24) in Verschließrichtung gedreht wird. 30 35 40
- Revendications** 45
1. Serrure à clé dans laquelle le mécanisme de reconnaissance de clé comprend une pluralité de leviers (5) ayant chacun un ventre (10) qui est parcouru par un pas respectif d'une clé à panneton (24) lorsque cette dernière tourne dans la serrure, pour ainsi déplacer les leviers (5) dans des positions relatives sélectionnées dans lesquelles ils permettent ensemble le retrait du pêne (3) ou de tout autre organe de fermeture de ce type de sa position de fermeture dans sa position d'ouverture, au moins une extrémité des trajectoires respectives parcourues par la clé (24) sur les ventres (10) des leviers se trouvant à des points différents sur différents leviers (5); comprenant un organe à barillet (12) devant tourner avec la clé correcte (24) et ayant une fente longitudinale (13) pour recevoir le panneton; et caractérisée par un organe d'arrêt (16) qui, dans une première position, empêche l'organe à barillet (12) de tourner jusque dans une position qui permette à sa fente (17) de venir en regard d'une région des ventres (10) des leviers, dans laquelle lesdits points différents sont situés, ledit organe d'arrêt (16) étant lié (18/19) à l'organe de fermeture (3) de manière à empêcher le déplacement de l'organe d'arrêt (16) de ladite première position dans l'état de fermeture de l'organe de fermeture (3), mais l'organe d'arrêt (16) étant déplaçable de ladite première position, par mouvement de la clé correcte (24) lorsque cette dernière est tournée pour faire bouger l'organe de fermeture (3) dans son état d'ouverture. 50
2. Serrure selon la revendication 1, dans laquelle ledit organe à barillet (12) est compris dans un organe à barillet et à feuille (11), dont la portion à feuille (14) butte (20/21) contre l'organe d'arrêt (16) pour empêcher l'organe à barillet (12) d'être tourné comme mentionné précédemment lorsque l'organe d'arrêt (16) est dans sa dite première position. 55
3. Serrure selon la revendication 2, dans laquelle l'organe d'arrêt (16) est prévu pour pouvoir glisser parallèlement à l'organe de fermeture (3) et la liaison (18/19) de l'organe d'arrêt (16) à l'organe de fermeture (3) compense la perte de mouvement de l'un à l'autre en ce que le mouvement de l'organe de fermeture dans un sens ou dans l'autre entre ses positions de fermeture et d'ouverture entraîne le mouvement parallèle de l'organe d'arrêt (16).
4. Serrure selon la revendication 3, dans laquelle le mouvement de l'organe d'arrêt (16) s'éloignant de sa dite première position s'effectue par la venue en butée (21) de ladite portion à feuille (14) contre l'organe d'arrêt (16) après le commencement du mouvement de l'organe de fermeture (3) vers sa position d'ouverture lorsque la clé correcte (24) est tournée dans le sens de l'ouverture, et le mouvement de retour de l'organe d'arrêt (16) dans sa dite première position s'effectue par la liaison (18/19) de l'organe d'arrêt (16) à l'organe de fermeture (3) lors de la dernière partie du mouvement de l'organe de fermeture (3) en direction de sa position de fermeture lorsque la clé correcte (24) est tournée dans le sens de fermeture.

Fig. 1.

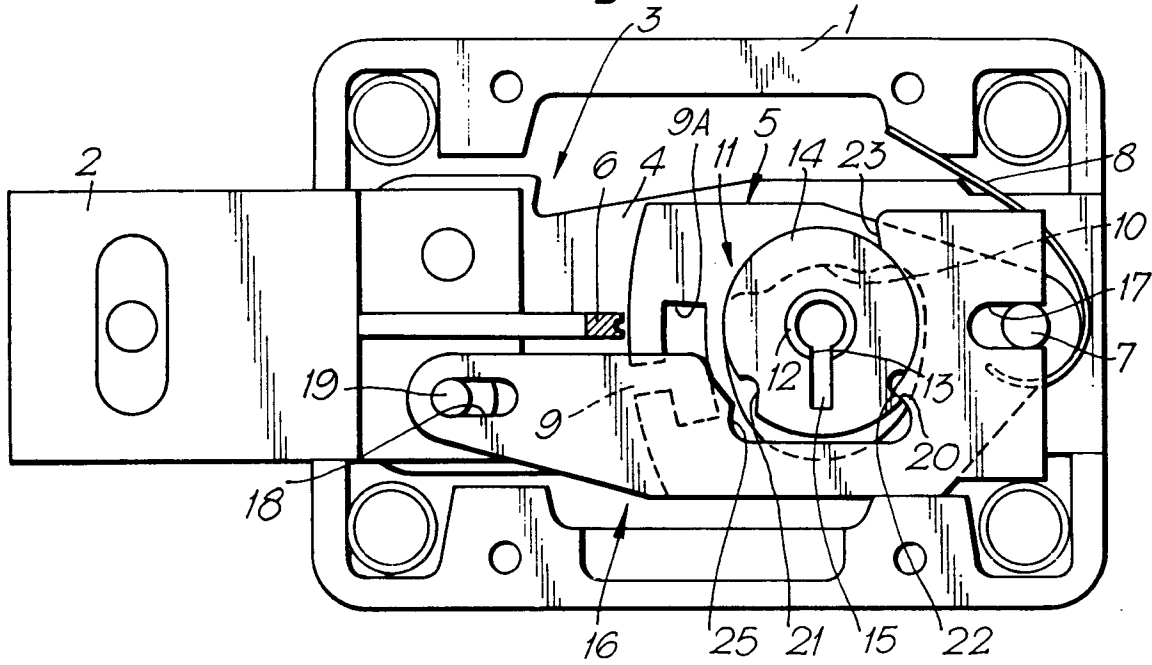

Fig. 2.

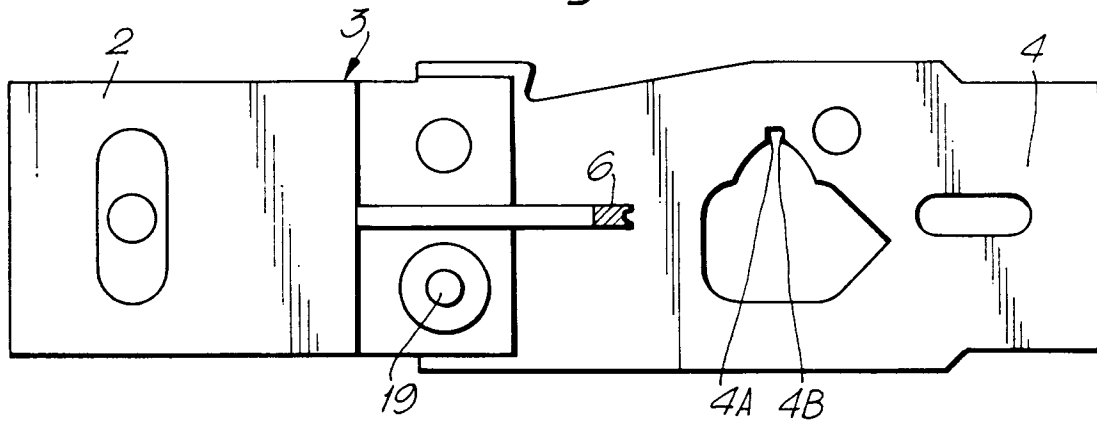

Fig. 3.

