

12 **EUROPEAN PATENT APPLICATION**

21 Application number: **87308262.2**

51 Int. Cl.4: **E03D 9/03 , A47K 5/12**

22 Date of filing: **18.09.87**

30 Priority: **20.09.86 GB 8622707**

43 Date of publication of application:  
**30.03.88 Bulletin 88/13**

64 Designated Contracting States:  
**AT BE CH DE ES FR GR IT LI LU NL SE**

71 Applicant: **POLYTOP PLASTIC LIMITED**  
**Bluebridge Industrial Estate**  
**Halstead Essex CO9 2SY(GB)**

72 Inventor: **Barratt, Mark**  
**16 Gray Close**  
**Earls Barton Northamptonshire, NN6 0PT(JP)**

74 Representative: **Knowles, Audrey Elizabeth et al**  
**624 Pershore Road**  
**Selly Park Birmingham B29 7HG(GB)**

54 **Device for dispensing a quantity of liquid from a container.**

57 A device (4) for dispensing a quantity of liquid from a container (1) has a seating member (14) for mounting in the neck (11) of the container (1) and a control member (15) arranged for limited axial sliding movement within the seating member (14) between an inner position (Figure 6) and an outer position (Figure 5) for controlling discharge of the liquid.

The seating member (14) and control member (15) are of stepped profile and define therebetween a transfer chamber (49) and an outlet chamber (51). The seating member (14) has an inlet port (31) opening into the transfer chamber (49) and an outlet port (50) leading from the transfer chamber (49) to the outlet chamber (51).

In the inner position, a wall portion (35) of the control member (15) engages the seating member (14) to close the outlet port (50) and a valve head (42) on the control member (15) disengages a valve seating (29) on the seating member (14) to open the inlet port (31) permitting flow of liquid from the container (1) into the transfer chamber (49).

In the outer position, the valve head (42) engages the valve seating (29) to close the inlet port (31) and the wall portion (35) disengages the seating member (14) to open the outlet port (50) allowing flow of the liquid from the transfer chamber (49) to the outlet chamber (51) from where it is dispensed.

In a preferred application, the control member (15) is adapted for responsive movement to change in the water level in a toilet cistern for automatically dispensing a measured quantity of treatment liquid each time the toilet is flushed.

**EP 0 261 882 A1**

## DEVICE FOR DISPENSING A QUANTITY OF LIQUID FROM A CONTAINER

This invention relates to a device for dispensing a quantity of liquid from a container, in particular, but not exclusively, the device is for delivering a small amount of a liquid disinfectant or cleaner into the water in a domestic toilet cistern.

It has already been proposed to have devices which are adapted to be mounted within a cistern in contact with the water therein so as to dispense a treatment substance such as disinfectant or cleaner into the water. Typical of the simplest kind of known device is a holder for or containing a block of solid treatment substance which has a slow rate of dissolution and which hangs within the cistern to be in contact with the cistern water when the cistern is recharged after flushing. These solid treatment blocks are not entirely satisfactory and the main problems are of the rate of dissolution and disintegration of the block or interference with the flushing valve in the event that the block container or hanger falls into the cistern.

It has also been proposed previously to have a container for a treatment liquid of which the outlet of the container is controlled by a valve which is opened by a float device that is arranged to move on fluctuations of the water level in the cistern and thereby operate the valve. Such float operated devices have also not been entirely satisfactory because of the lack of space within the normal cistern for a float in addition to the normal float operated ball valve for mains inlet supply for recharging the cistern as well as the flushing valve mounted also in the cistern. Furthermore, such float controlled devices usually have two operational effects due to float movement on fall of water level and the rise of water level, and in some devices this leads to double dosing on each flushing operation of the cistern.

In some water supply installations, complex metering valve arrangements are arranged to dose metered amounts of a treatment substance into the water supply line. Normally such arrangements are found in institutional installations and are for very specific purposes not suitable for general use in domestic or like installations where critical control requiring plumbed in metering valves is not essential. Furthermore, such installed arrangements are very costly and could not be justified in a domestic situation where hygienic control is merely desirable.

There are other applications where a small quantity of liquid from a container is required to be dispensed as a single dose mode with the container being automatically sealed or closed thereafter. Such other applications are also referred to

later herein and the liquid may comprise a soap or detergent, water additive, essence, shampoo etc., and herein the term "liquid" is intended to include all such liquid substances or compositions.

5 An object of this invention is to provide a device for use with a container holding a liquid, and the device is arranged to dispense a small quantity of the liquid from the container when supported in an inverted mode and to be sealed closed after a  
10 dispensing discharge of the liquid.

15 A further object of this invention is to provide a dispensing device of simple construction which is adapted for mounting in the neck of a container for the liquid so that the treatment liquid can be dispensed from the container when located in the cistern or like reservoir of water in response to a change of water level.

20 Other objects of this invention will be referred to later herein in association with remarks about the technical advantages of the invention and an exemplary embodiment thereof.

25 According to this invention we provide a device for dispensing a small quantity of liquid from a container, the device comprising a tubular seating member and a control member, the seating member having a mounting flange at one end to mount the device in the mouth of the container with the seating member depending into the container to  
30 confine liquid within the container for controlled discharge through an inlet port defined by a valve seating at the other end of the seating member, the control member having a body received within the seating member and mounted for limited relative axial displacement between inner and outer positions, the control member further having a valve  
35 head connected to the body by a neck portion extending through the seating member so that the valve head engages the valve seating when the control member is in the outer position to close the inlet port to prevent discharge of liquid from the interior of the container, the inlet port leading to a transfer chamber defined between the seating member and the body of the control member into  
40 which treatment liquid is discharged when the control member is in the inner position in which the valve head is disengaged from the valve seating, the seating member having an outlet port axially spaced from said inlet port and arranged to be closed by the control member when the control  
45 member is in the inner position in which the valve head is disengaged from the valve seating enabling liquid to be discharged into the transfer chamber and retained therein, and the outlet port being open to discharge the quantity of liquid held in the transfer chamber when the control member is dis-

placed to the outer position closing the inlet port to prevent discharge of the liquid from the interior of the container into the transfer chamber, the arrangement of the device being such that in use the device is mounted in the mouth of a container holding the liquid and the container is inverted so that when the control member is in the outer position treatment liquid can be discharged and dispensed through the outlet port and when the control member is displaced to the inner position, the inlet port is opened to fill the transfer chamber of which the outlet port is closed.

By this invented device, the liquid confined with a container may be dispensed as a small quantity dose according to the designed volume of the transfer chamber by a simple displacement of the control member in one sense whilst the transfer chamber is recharged on return movement of the control member that closes the outlet port from the transfer chamber.

The body of the control member is preferably of tubular form providing a void chamber open for admission of air and/or water in use of the device.

In a preferred application of the invented device, the displacement of the control member is caused by a change in water level in a cistern in which the container is suspended with the mouth of the container being arranged at a level in which the device is covered by the water when the cistern is full and the control member is in the inner position due to air and/or water pressure acting on the control member and, on a reduction of level of the water on operation of the flushing valve of the cistern, then the mouth of the container with the device is uncovered and the control member is displaced to the outer position to dispense the small quantity of treatment liquid from the transfer chamber through the outlet port into the cistern. On refilling of the cistern, the control member is acted on by the air and/or water to return to the inner position whereby the transfer chamber is recharged ready for the next actuation on change of water level in the cistern.

The tubular form of the control body with the void chamber permits air and/or water to be admitted or released. Therefrom on such relative change in water level with the control body being responsive to the floatation or pressure affects of air and/or water in the void chamber.

As will be appreciated, in this particular application the small quantity which is dispensed by the invented device from the container is a single dose for each filling of the cistern, and the dispensing of each dose is automatic in response to the change in water level. The control member serves

to respond to the change in water level in this preferred application, but the control member could be displaced by some other means in other applications.

In the invented device, it is preferred that the valve head is larger than the inlet port opening through the seating member so that the control member is retained and assembled to the seating member by the neck which extends through the inlet port opening with the valve head preventing the control member from being displaced through the inlet port opening. By such an arrangement, the construction is simple.

In a preferred construction of the invented device, the valve head of the control member is of frusto-conical form to engage the inlet port of which the seating has a face of complementary form to engage the valve head. By such a preferred form of the valve head and inlet port seating, a large surface area is provided for sealing engagement and the control member is self-centering with respect to the seating member when engaged with the seating closing the inlet port.

It is also preferred that the control member be received within the tubular seating member when the control member is in the inner position so that the two members are nested one within the other and do not protrude substantially beyond the mouth of a container when mounted therein by the mounting flange of the seating member. By such an arrangement, the container mouth can be closed by a suitable cap or closure to enclose the device and to seal the liquid contents of the container for transport, packaging or the like.

A further feature of the invented device is to provide the control member body of hollow interior form having an open end remote from the valve head providing the void chamber into which air and/or water can be displaced and/or received. By this special hollow form, the control member can be of very low or minimum weight for displacement axially by air and/or water effects within the void chamber or by other displacement force of a low degree.

Other features of the invented device will be referred to later herein, and this invention is also deemed to relate to the combination of a container with the device mounted in the mouth of the container.

The invention will now be described with reference to an exemplary embodiment depicted in the accompanying drawings wherein:-

FIGURE 1 is a schematic view showing a typical installation of a container including the invented dispensing device in a toilet cistern;

FIGURE 2 is a view of the container shown in the closed upright position enclosing the invented device;

**FIGURE 3** is a view of the closed container inverted within a cistern having water at a high level (WH) and prior to opening the container for use, the invented dispensing device being depicted by a scrap section;

**FIGURE 4** is a part sectional view similar to that of Figure 3 showing the container opened within the cistern having water at an intermediate level (WI) therein with the dispensing device being shown in an intermediate charging position;

**FIGURE 5** is a part sectional view similar to that of Figure 4 but with the water at a low level (WL) with the dispensing device being shown in the dispensing position;

**FIGURE 6** is an enlarged detail sectional view of the members of the dispensing device with the control member being in the inner limit position;

**FIGURE 7** is a detail sectional view of the control member as shown in Figure 6;

**FIGURE 8** is an end view of the control member in the direction 8'-8' given in Figure 7;

**FIGURE 9** is a detail sectional view of the seating member as shown in Figure 6; and

**FIGURE 10** is an end view of the seating member in the direction 10'-10' given in Figure 9.

With reference to the arrangement of the typical installation shown in Figure 1, a container 1 is mounted by a hanger 2 so as to be inverted within a cistern 3 with a dispensing device 4 according to this invention being mounted in the mouth of the container to dispense treatment liquid 5 confined within the container 1 into the water 6 within the cistern 3.

In known manner, water is admitted to the cistern through an inlet valve generally depicted at 7 and the toilet bowl 8 may be flushed by water from the cistern on the action of a flushing valve generally depicted at 9 connected to the bowl 8 by a down pipe 10. As will be understood, the arrangement and construction of the cistern and inlet and flushing valves is not relevant to this invention, but the invented device is designed to release automatically a small dose or quantity of liquid from the container on each flushing operation. Conventionally, the treatment liquid would be a disinfectant and may include a colouring agent to give a visible indication of water treatment.

With reference to Figures 2 and 3, these show the container 1 which is of a convenient bottle shape having a neck 11 defining a mouth 12 which is closed by a cap 13 engaged over the neck 11. The container body is provided with two pierced lugs 1' for engagement with the hanger 2 which may be of any suitable shape or form to support the inverted container over the edge of the cistern

3 with the neck 11 of the container 1 being located at a position intermediate the high water level (WH) shown in Figure 2 and the low water level (WL) shown in Figure 5.

The invented dispensing device 4 is mounted in the mouth 12 of the container 1 and comprises a seating member 14 and a control member 15. As shown in Figure 3, when the container 1 is closed by the cap 13 the dispensing device 4 is confined wholly within the mouth 12 and the treatment liquid 5 is confined within the container 1.

For automatic operation of the dispensing device 4, the cap 13 is removed and in response to changes in the water level in the cistern between levels (WH) and (WL) through the intermediate level (WI) shown in Figure 4, the control member 15 is displaced relative to the seating member 14 between an inner limit position such as shown in Figures 4 and 6, and an outer limit position as shown in Figure 5. In the outer limit position as shown in Figure 5, once a single dose of liquid has been discharged, then the remainder of the treatment liquid 5 is confined within the container and there is no further discharge of liquid until the device is actuated again.

The dispensing device will now be more particularly described with reference to the detail views in the accompanying drawings.

The seating member 14 and the control member 15 are mouldings of suitable plastics material and are shown for clarity as integral although this is not essential.

The seating member 14 has a substantially tubular hollow body 20 having an outer cylindrical wall portion 21 from which an annular flange portion 22 extends with three radial circumferentially spaced webs 23 extending between the outer faces of the wall portion 21 and the flange portion 22 to provide a reinforcement. On the inner face of the body at the junction of the wall portion 21 and the flange 22 there is a seating bead 24 for engagement by the control member 15. A mounting flange 25 of cylindrical form extends from the annular flange 22 and terminates in an outwardly directed edge lip or rim 26. The mounting flange 25 and the edge lip 26 are complementary to the inner shape of the mouth and neck of the container for assembling the dispensing device to the container by an interference fit or by bonding or adhesive so that the dispensing device can be firmly mounted to the container and cannot be pushed inwardly into the interior of the container.

The body 20 of the seating member 14 also includes an inner wall portion 27 of substantially cylindrical form of less diameter than the outer wall portion 21 and which extends from an inclined shoulder portion 28. The inner free end of the body 20 terminates in a valve seating 29 that extends

from a convergent end wall portion 30 of the body 20. The seating 29 is arranged co-axially with respect to the inner and outer wall portions 27,21 and provides an inlet port 31 arranged to be opened to the interior of the container in use for liquid within the container to be admitted to flow through an inner passageway 32 to a transfer port 33 defined partly by the re-entrant end face 47 of the valve seating 29.

The control member 15 has a substantially hollow body 34 having an outer cylindrical wall portion 35 of a diameter for sliding sealing engagement with a limited axial length of the inner wall portion 27 of the seating member 14 as will be later described. The outer end of the wall portion 35 is formed with a radiused shoulder portion 36 that has an outer face for sealing engagement with the seating bead 24 of the seating member 14.

As shown in Figure 6, when the control member is in the extreme inner position, the shoulder portion 36 engages the seating bead 24 to locate the control member 15 against displacement inwardly of the seating member 14 as well as to seal the two members together so that any liquid cannot leak past the seal thereby achieved.

The body 34 of the control member 15 also includes a substantially cylindrical outer flange 37 extending from the shoulder portion 36 and this terminates in an outwardly directed edge rim 38 having circumferentially spaced apart recesses 39. As will be understood, the rim 38 is arranged for engagement by the cap, and the recesses 39 are provided to facilitate flow of treatment liquid when discharged through the device as later explained.

The body 34 of the control member 15 further includes an inner wall portion 40 of substantially cylindrical form that is of less diameter than the outer wall portion 35 but co-axial therewith. Extending between the inner and outer wall portions 40,35 there is a converging hip wall portion 41.

The control member 15 also comprises a valve head 42 which is connected to the body 34 by a cylindrical neck 43 extending from a shoulder wall portion 44 that converges from the inner wall portion 40 and which extends up to the end wall portion 45 of the body to complete a partition wall extending between the seating member 14 and the control member 15.

The valve head 42 has a frusto-conical outer face extending to the same cone angle as the adjacent face of the frusto-conical form of the valve seating 29 of the seating member 14 so that when the control member is displaced into the outward extreme position as shown in Figure 4, the adjacent frusto-conical faces of the seating 29 and the valve head 42 engage each other to close the inlet port 31. The valve head 42 is provided with a well recess 46 of conical shape, and this is for stabilis-

ing and centering the control member 15 during operation and use when liquid may fill the well recess 46 to increase the overall mass of the control member 15 for gravity displacement to the position depicted in Figure 6.

The face of the shoulder wall portion 44 of the control member 15 defines one annular wall of the transfer port 33 with the other wall of the port 33 being defined by the re-entrant annular end face 47 of the seating 29 as aforementioned. The seating 29 is provided with three axially extending and circumferentially spaced short grooves or recesses 48 for assisting in flow of liquid from the lower portion of the passageway 32 through the transfer port 33 whilst the inlet port 31 is open.

The transfer port 33 leads to a transfer chamber 49 which is defined between the seating member 14 and the control member 15 extending as a substantially annular chamber between the inner wall portion 27 of the seating and both the inner wall portion 40 and hip wall portion 41 of the control member. As can be seen from Figure 6, when the transfer port 33 is open, the transfer chamber 49 is closed at the outer end to confine admitted liquid therein as the outer wall portion 35 of the control member is in sealing engagement with the inner wall portion 27 of the seating member over a significant axial length.

The transfer chamber 49 has an outlet port 50 which is defined by the seating member 14 at the intersection of the inner wall portion 27 and the shoulder portion 27 which diverges away from the inner wall portion 27 at such intersection. The port 50 leads to an outlet chamber 51 which extends between the outer wall portion 21 of the seating member 14 and the outer wall portion 35 of the control member 15. The seating member has three axially extending and circumferentially spaced short grooves or recesses 52 for assisting in flow of liquid from the outlet port 50 and through the outlet chamber 51 when the control member 15 is displaced axially into the outward position with the outlet port 50 open as shown in Figure 5.

The valve head 42 has a maximum diameter which is larger than the inlet port 31 whilst the neck 43 joining the valve head to the body 34 has a diameter which enables the neck 43 to move axially through the seating 29 between the extreme inner limit as just described when the seating bead 24 is engaged and the extreme outer limit when the valve head 42 seats on the valve seating 29 to close inlet port 31. By this arrangement of the valve head and shoulder, the control member 15 is supported on and assembled to the seating member 14 for such relative axial movement for operation of the invented device.

In the device, the relative axial lengths of the co-operating faces of the control member 15 and the seating member 14 which close the outlet port 50 and the transfer chamber 49 are arranged and designed so that when the control member is in the inner limit position as shown in Figure 6, then the outlet port 50 from the transfer chamber is closed, and as the control member moves to the outer limit position, then the outlet port 50 from the transfer chamber 49 is opened by disengagement of the co-operating faces when the inlet port 31 is closed by the valve head 42. Similarly, on relative displacement of the control member 15 inwardly of the seating member 14, the outlet port 50 is closed immediately prior to, or simultaneously with the opening of the inlet port 31 so that the transfer chamber 49 is isolated from water or the like lying near or within the outlet chamber 51.

The hollow interior of the body 34 of the control member 15 provides an open void 53 into which air or water may enter during operation of the device on a change in water level so as to cause the axial displacement of the control member for dispensing the liquid and for recharging the transfer chamber for the next successive dispensing discharge. The operation of the invented device in this exemplary application shown in Figure 1 will now be described.

In use of the dispensing device as aforesaid, the container is supported in the inverted position as shown in Figure 1, and the control member 15 is in the inward limit position as shown in Figures 3 and 6 until the cap is removed. When the control member 15 is at this inward position, the transfer chamber 49 is filled with liquid which flows through the inlet port 31 through the passageway 32 and through the transfer port 33 into the transfer chamber 49.

On outward displacement of the control member 15, the control member moves outwardly of the seating member 14 until it reaches a position when the valve head 42 seats within the seating 29 closing the inlet port 31 to prevent any further treatment liquid flowing into the transfer chamber 49. The small amount of treatment liquid contained within the transfer chamber 49 is then released from the transfer chamber 49 through the outlet port 50 which is then open as the hip shoulder 41 clears the inner wall portion 27 of the seating body 20.

The liquid can then flow from between the outer wall portion 21 and the seating bead 24 of the seating member and the outer wall 35 with shoulder 36 to be discharged and dispensed into water confined within the cistern and as depicted in Figure 5. It should be noted that the particular

shape of the control member outer faces with the rim and recesses is such as to provide a weir with effective flow distribution around the periphery of the control member.

Assuming that the dispensing device has been caused to discharge and dispense the liquid into the cistern when the water is at low level (WL), the water level will start to rise as the cistern refills through the intermediate water level (WI) as shown in Figure 4.

When the water level reaches the rim 39 of the control member, air and/or water will enter the void chamber 53 and pressure will be exerted on the control member to displace this axially inwards of the seating member 14. On such inward displacement, the outlet port 50 from the transfer chamber 49 is closed and the valve head 42 is lifted from its engagement with the valve seating 29 to open the inlet port 31 and the passageway 32 so that the transfer chamber can be recharged with liquid through the transfer port 33.

Whilst the water level is at the intermediate level or higher level the mouth of the container with the device is submerged, the control member is maintained in the inward position with the transfer chamber being recharged ready for the next dispensing operation.

When the level of the water in the cistern changes to a lower level (WL), as the rim 39 of the control member becomes free of contact with the water then the void chamber 53 is opened so that the control member 15 is no longer subject to the supporting effect of the air and/or water, then the control member may be displaced under gravity into the outer extreme position for discharge and dispensing of the treatment liquid as shown in Figure 5.

As will now be appreciated, this successive operation with the discharge and dispensing of the small volume of treatment liquid will proceed successively on each flushing/filling operation of the cistern with the liquid being dispensed during flushing and the device being recharged during cistern filling whilst no liquid can leak or be discharged from the container whilst the rim 39 is submerged below the level of the water.

In the embodiment as shown and described, the seating member and the control member are of generally stepped cylindrical tubular form with the transfer chamber being of generally annular form of which the volume may be designed in accordance with the selected axial length and relative diameters of the inner wall portions of the respective seating and control members. However it will be understood that the cross section of both the seating and the control members may not necessarily be circular and a square or rectangular cross sectional shape could be used.

Also in this preferred embodiment, the seating and control members are assembled together and supported by the frusto-conical form of valve head. However, this is not essential, and the two members could be assembled together for limited relative movement by inter-engaging ribs or grooves extending axially between the two members, for instance in the region of the outlet chamber. Alternatively, the control member could be supported for relative movement with respect to the seating member by a spider support located between the outer mounting flange of the seating and the flange of the control member.

In the application of the invented dispensing device which has been described herein discharging liquid into a water cistern, it is notable that the control member is designed to provide the void chamber for entrapping air and/or water for the responsive reaction of the control member on change of water level. Additionally, the control member has the particular shape to provide the weir over which the treatment liquid is discharged. However, the invented dispensing device has other applications for dispensing small quantities of liquid from a container which may be supported in an inverted manner.

Another suitable application for the invented dispensing device is for manual use in obtaining a limited quantity of soap or shampoo that might be confined within the container for discharge by manual operation of the control member which is merely pushed upwards by a hand held underneath the device to receive the quantity of liquid therein. Typical of such an application is for dispensing liquid soap or shower gel in an ablutionary shower installation wherein a container with the invented dispensing device may be supported for operation of the dispensing device when required. As the control member remains in the outward limit position when the liquid has been discharged, the dispensing device will operate as an automatic shut-off arrangement for single shot dispensing when the control member is pressed upwardly into the inward limit position.

Other analogous applications of the invented dispensing device are considered within the scope of this invention, and as will be understood, the shape and configuration of the exposed end of the control member may be designed for manual movement.

The invented dispensing device is simple both in construction and in use, and it has significant meritorious features as referred to herein.

## Claims

1. A device (4) for dispensing a small quantity of liquid from a container (1) characterised in that the device (4) comprises a tubular seating member (14) and a control member (15), the seating member (14) having a mounting flange (25) at one end to mount the device (4) in the mouth (12) of the container (1) with the seating member (14) depending into the container (1) to confine liquid within the container (1) for controlled discharge through an inlet port (31) defined by a valve seating (29) at the other end of the seating member (14), the control member (15) having a body (34) received within the seating member (14) and mounted for limited relative axial displacement between inner and outer positions, the control member (15) further having a valve head (42) connected to the body (34) by a neck portion (43) extending through the seating member (14) so that the valve head (42) engages the valve seating (29) when the control member (15) is in the outer position to close the inlet port (31) to prevent discharge of liquid from the interior of the container (1), the inlet port (31) leading to a transfer chamber (49) defined between the seating member (14) and the body (34) of the control member (15) into which treatment liquid is discharged when the control member (15) is in the inner position in which the valve head (42) is disengaged from the valve seating (29), the seating member (14) having an outlet port (50) axially spaced from said inlet port (31) and arranged to be closed by the control member (15) when the control member (15) is in the inner position in which the valve head (42) is disengaged from the valve seating (29) enabling liquid to be discharged into the transfer chamber (49) and retained therein, and the outlet port (50) being open to discharge the quantity of liquid held in the transfer chamber (49) when the control member (15) is displaced to the outer position closing the inlet port (31) to prevent discharge of the liquid from the interior of the container (1) into the transfer chamber (49), the arrangement of the device (4) being such that in use the device (4) is mounted in the mouth (12) of a container (1) holding the liquid and the container (1) is inverted so that when the control member (15) is in the outer position treatment liquid can be discharged and dispensed through the outlet port (50) and when the control member (15) is displaced to the inner position, the inlet port (31) is opened to fill the transfer chamber (49) of which the outlet port (50) is closed.

2. A device according to Claim 1 characterised in that the valve head (42) is engageable with the valve seating (29) in the outer position to limit outward displacement of the control member (15) relative to the seating member (14).

3. A device according to Claim 1 or Claim 2 characterised in that the valve head (42) and valve seating (29) have co-operating sealing faces of complementary frusto-conical form.

4. A device according to any one of the preceding Claims characterised in that the seating member (14) and control member (15) are assembled together and supported by the valve head (42). 5

5. A device according to any one of the preceding Claims characterised in that the control member (15) and seating member (14) have co-operating formations (36,24) engageable in the inner position to limit inward displacement of the control member (15) relative to the seating member (14). 10 15

6. A device according to any one of the preceding Claims characterised in that the control member (15) and seating member (14) have complementary axially extending wall portions (35,27) engageable to close the outlet port (50) when the inlet port (31) is open and disengageable to open the outlet port (50) when the inlet port (31) is closed. 20

7. A device according to any one of the preceding Claims characterised in that the seating member (14) is provided with a first set of grooves (48) to assist flow of liquid from the container (1) to the transfer chamber (49) when the inlet port (31) is open and a second set of grooves (52) to assist flow of liquid from the transfer chamber (49) to the outlet chamber (51) when the outlet port (50) is open. 25 30

8. A device according to any one of the preceding Claims characterised in that the end of the control member (15) remote from the valve head (42) is substantially flush with the mounting flange (25) of the seating member (14) in the inner position. 35

9. A device according to any one of the preceding Claims characterised in that the end of the control member (15) remote from the valve head (42) is provided with a weir (38,39) over which the liquid is discharged. 40

10. A device according to any one of the preceding Claims characterised in that the body (34) of the control member (15) is of tubular form in which the end remote from the valve head (42) is open providing a void chamber (53) for responsive movement of the control member (15) to change in level of a liquid into which the liquid from the container (1) is dispensed in use. 45 50

55

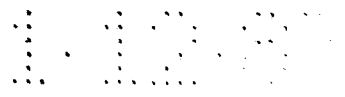

FIGURE 1

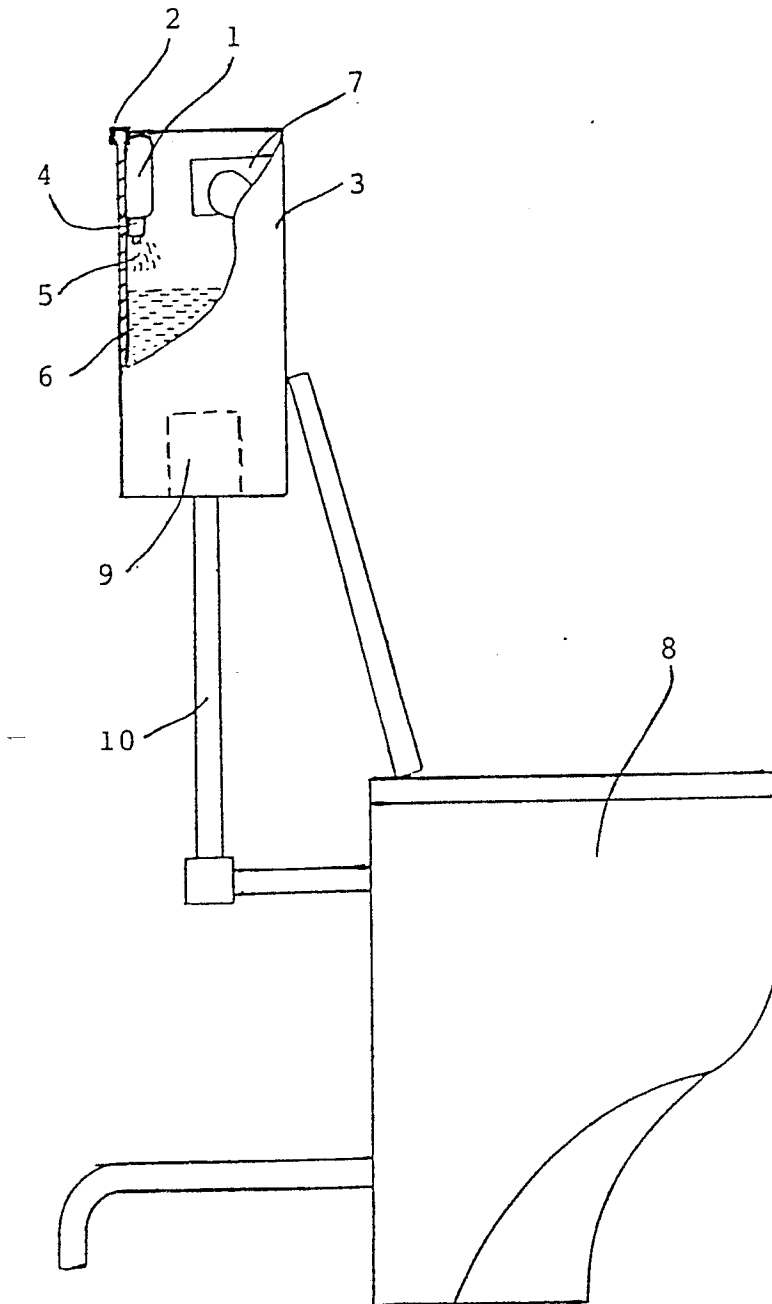

FIGURE 2

Patented July 1, 1958  
Development Division

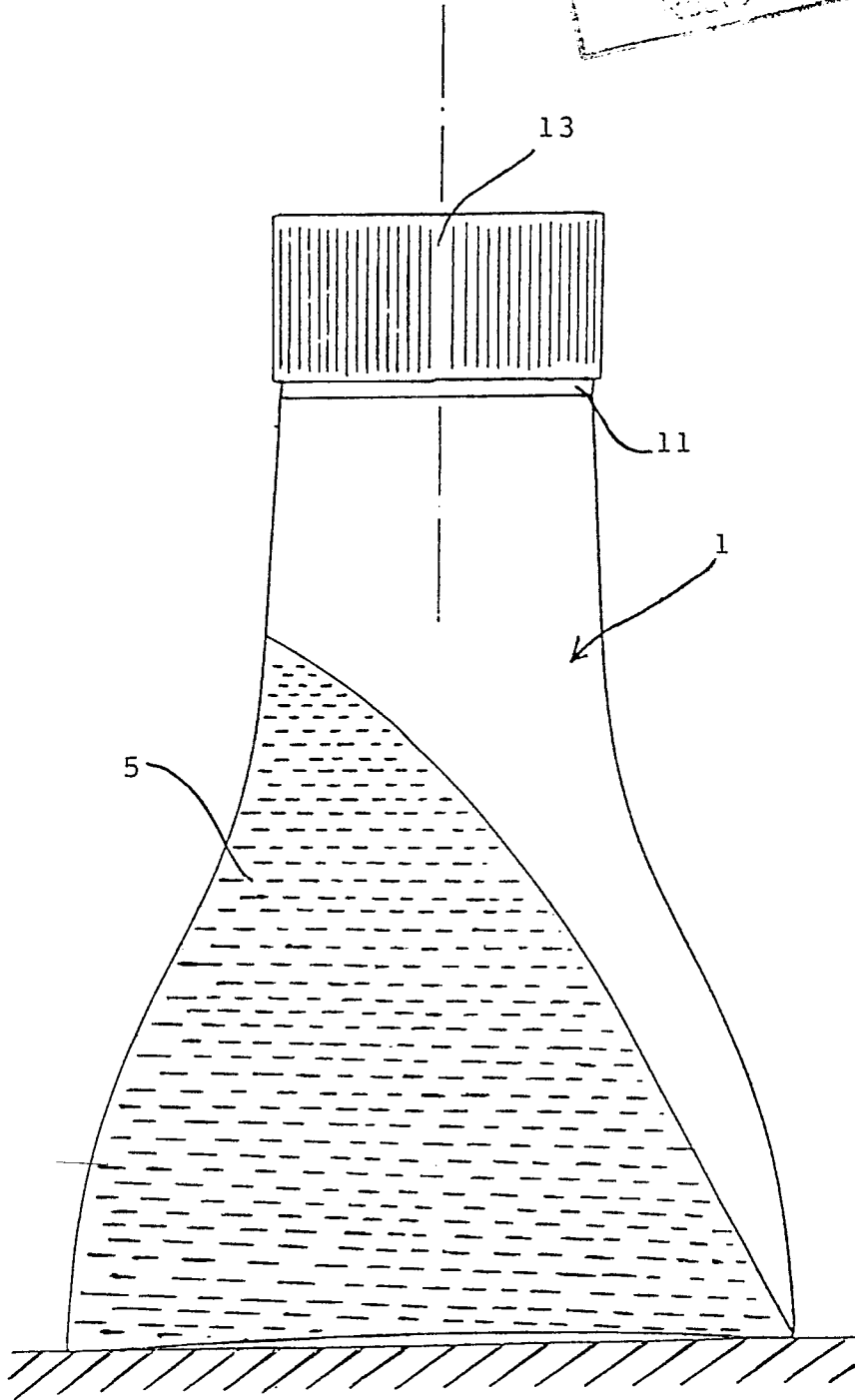

FIGURE 3

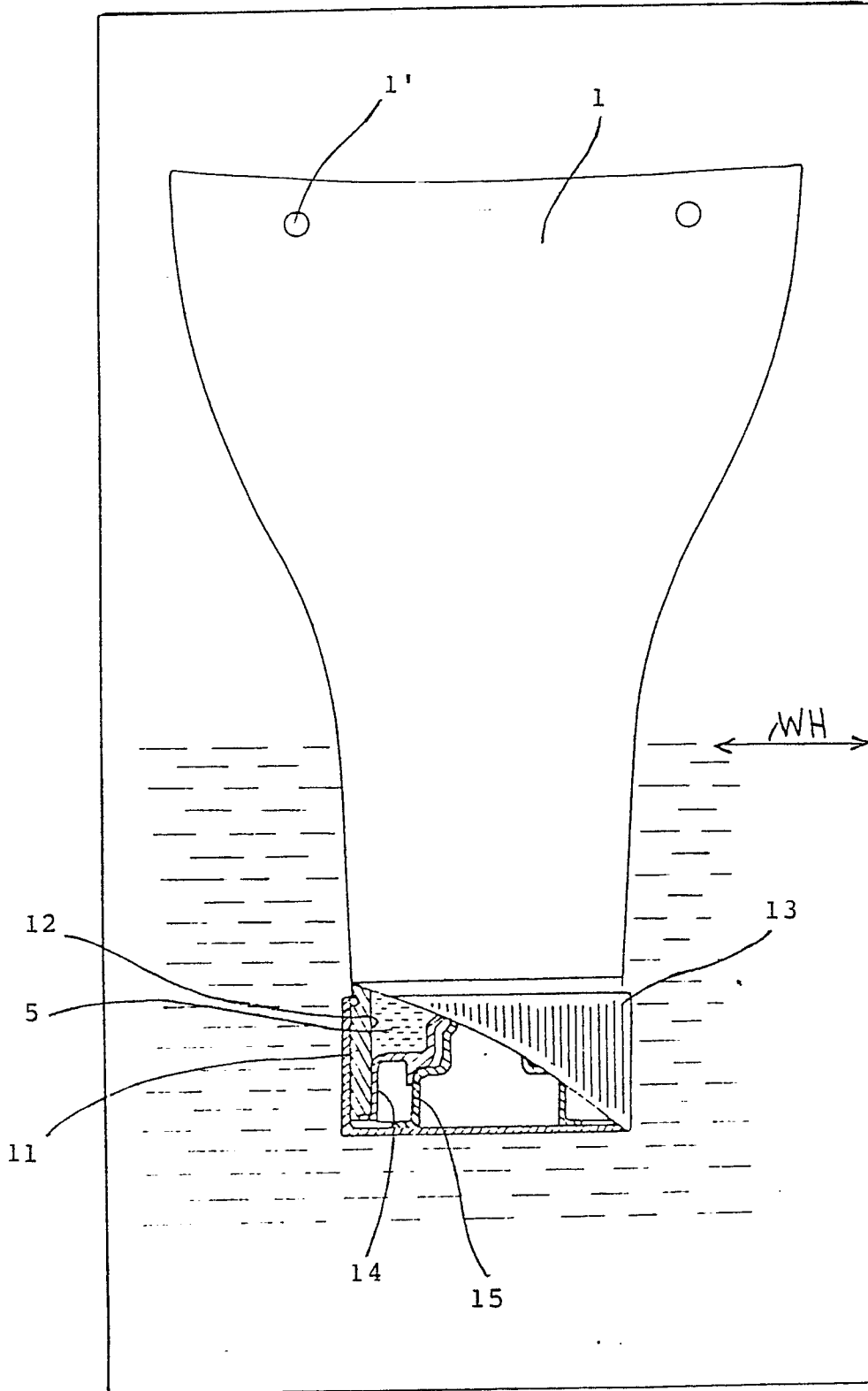

FIGURE 4

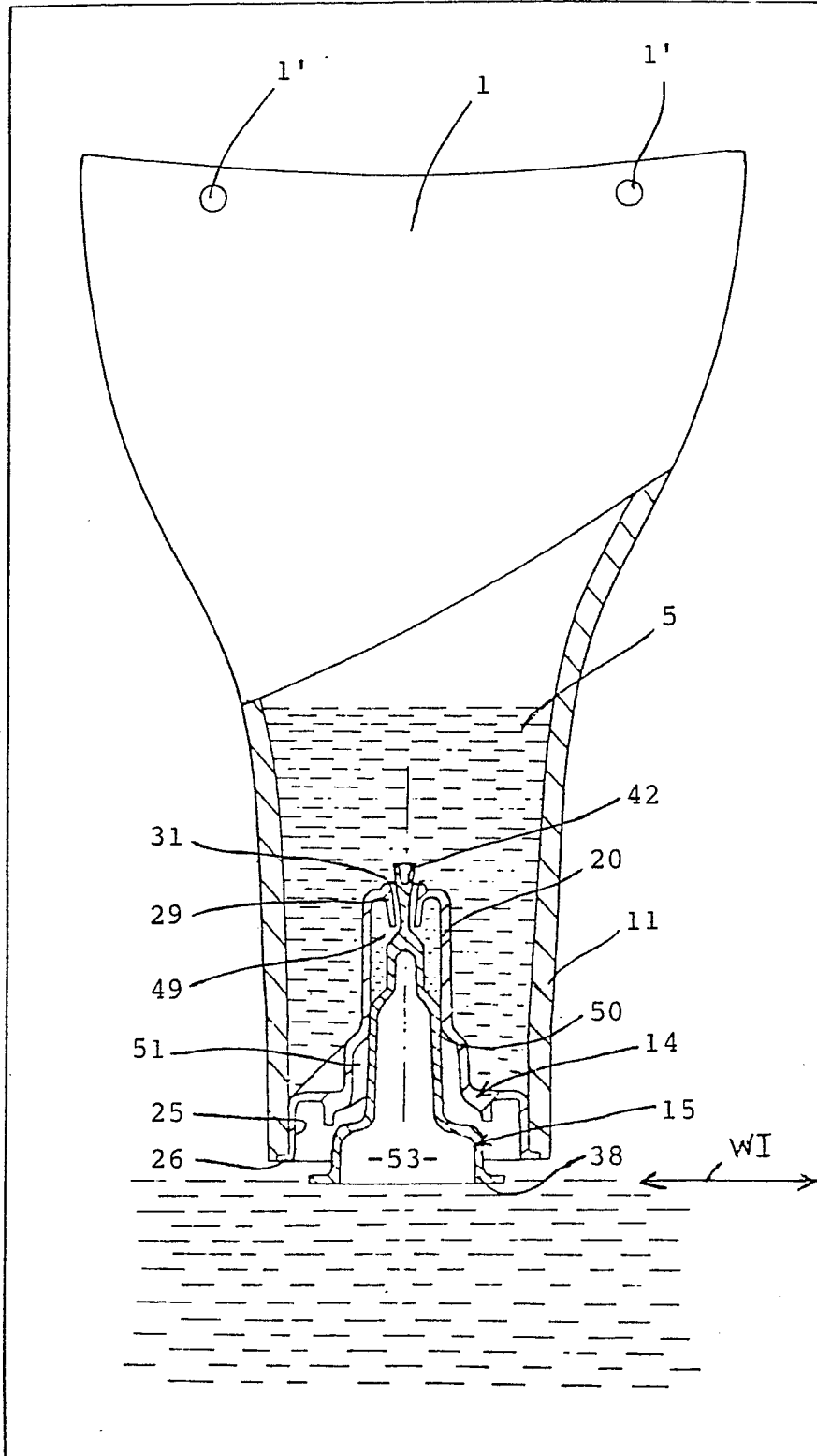

FIGURE 5

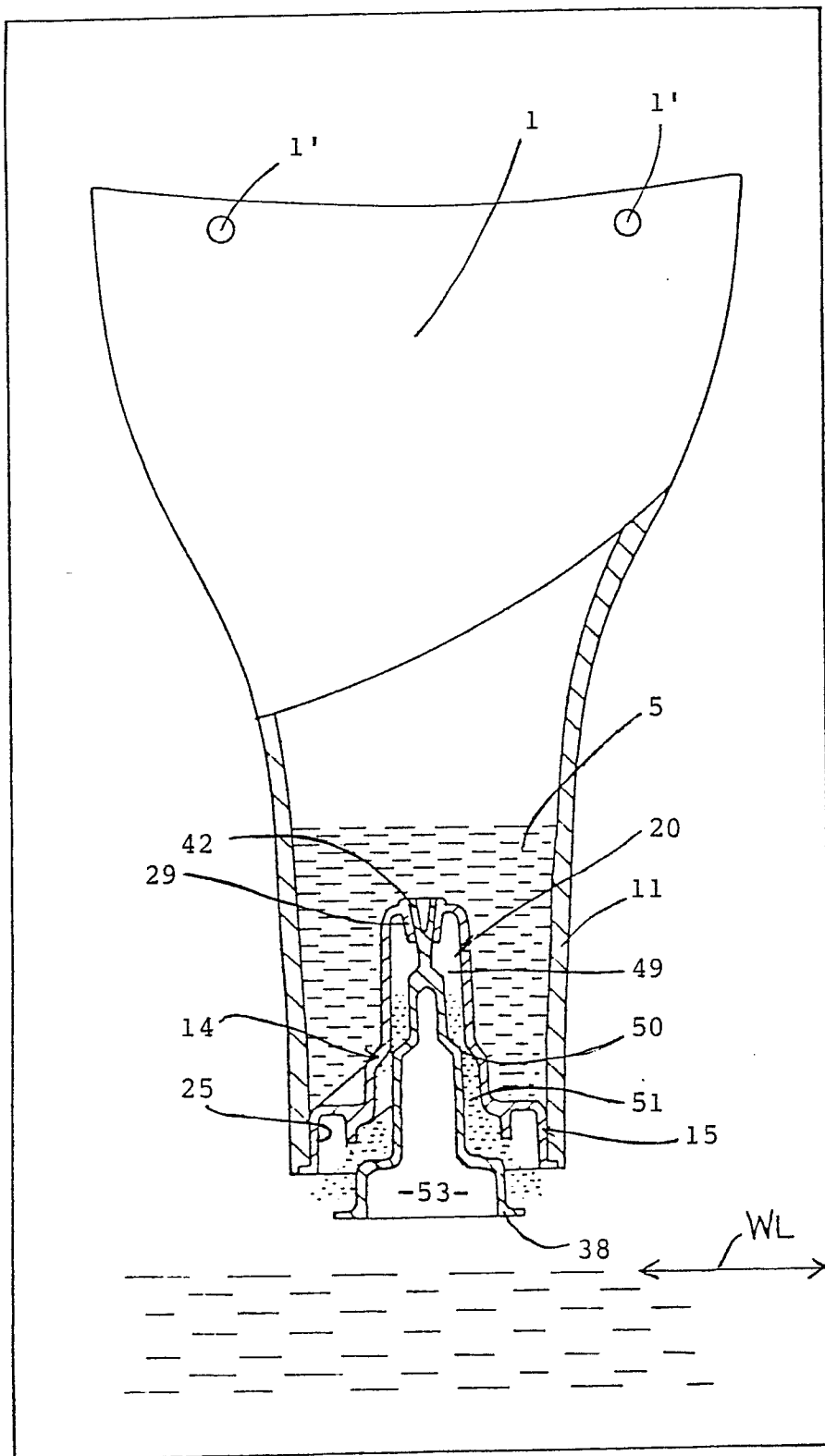
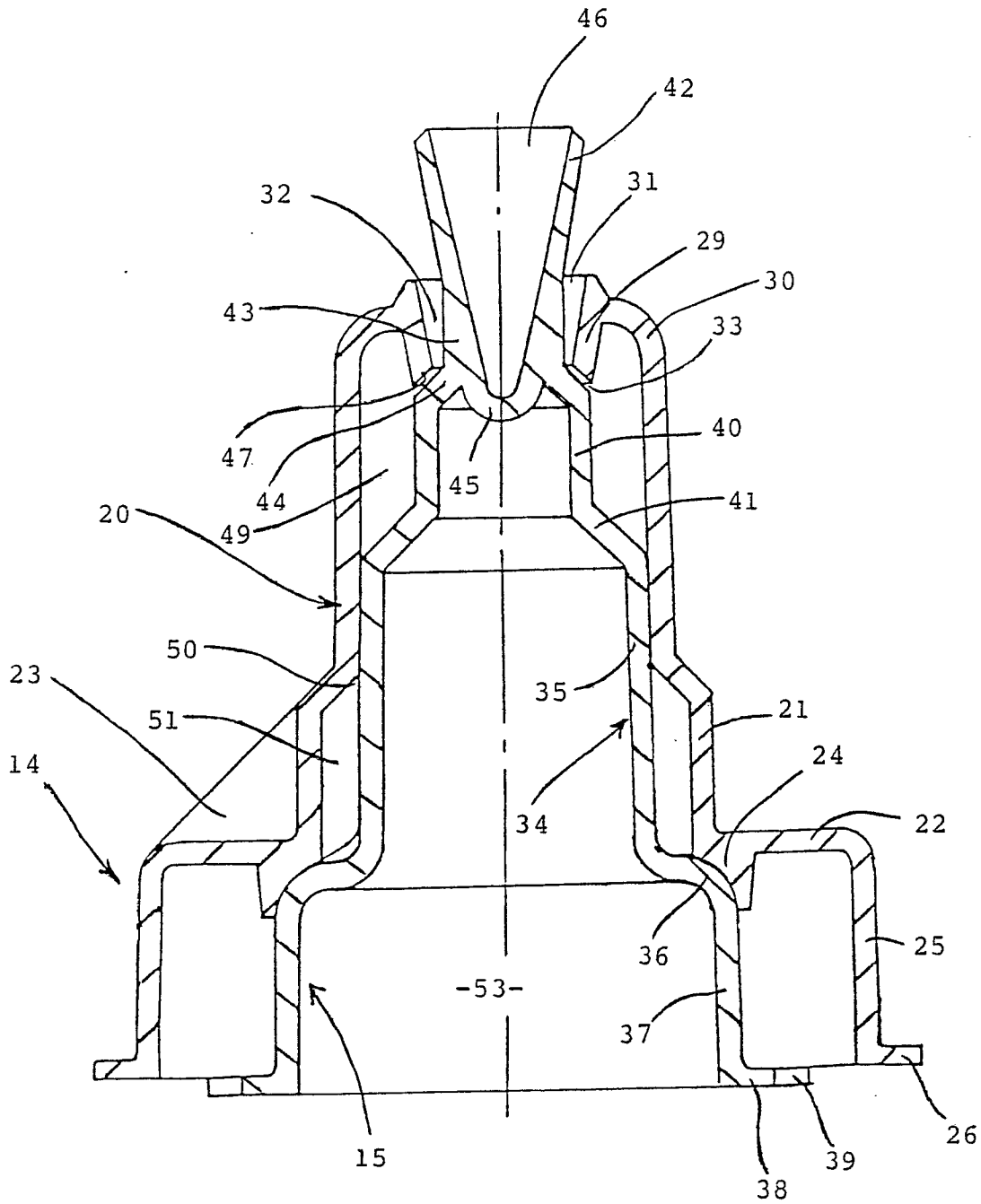

FIGURE 6



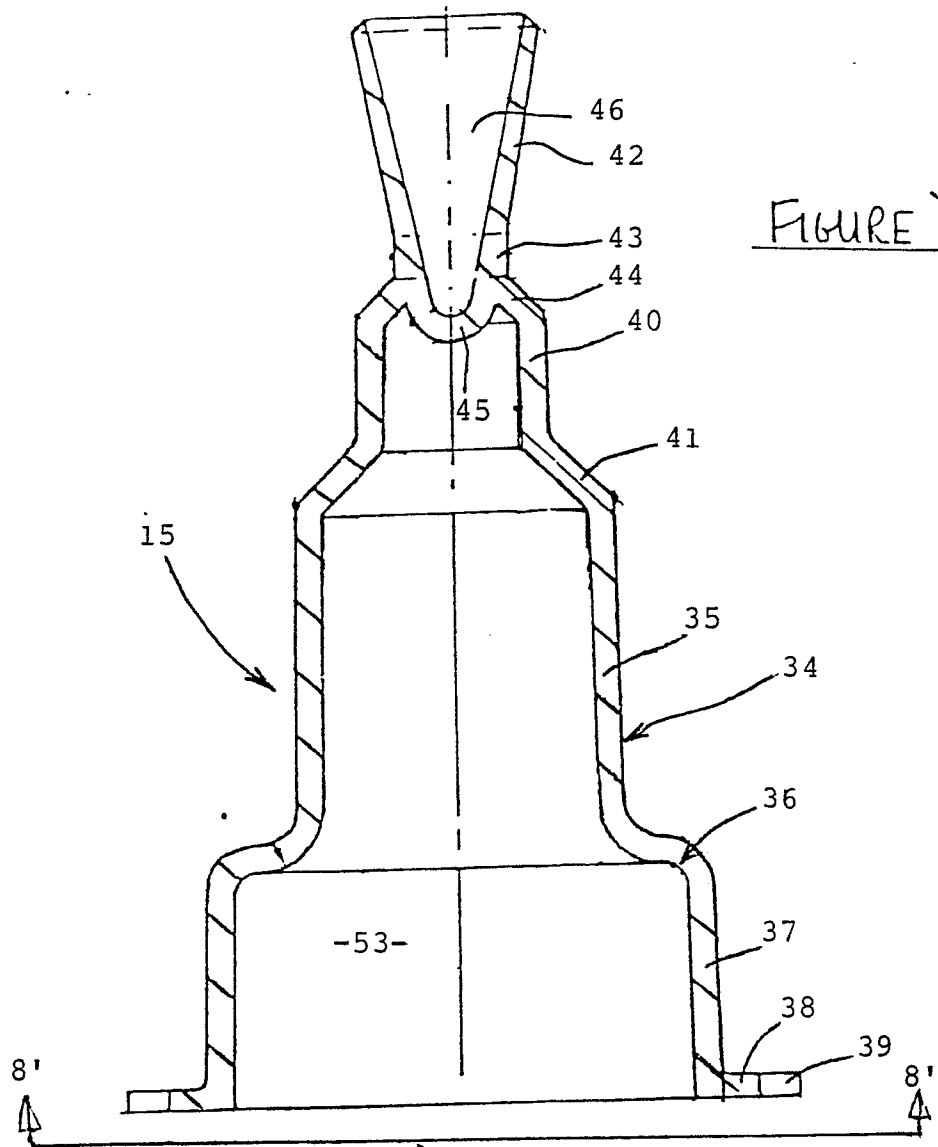

FIGURE 7

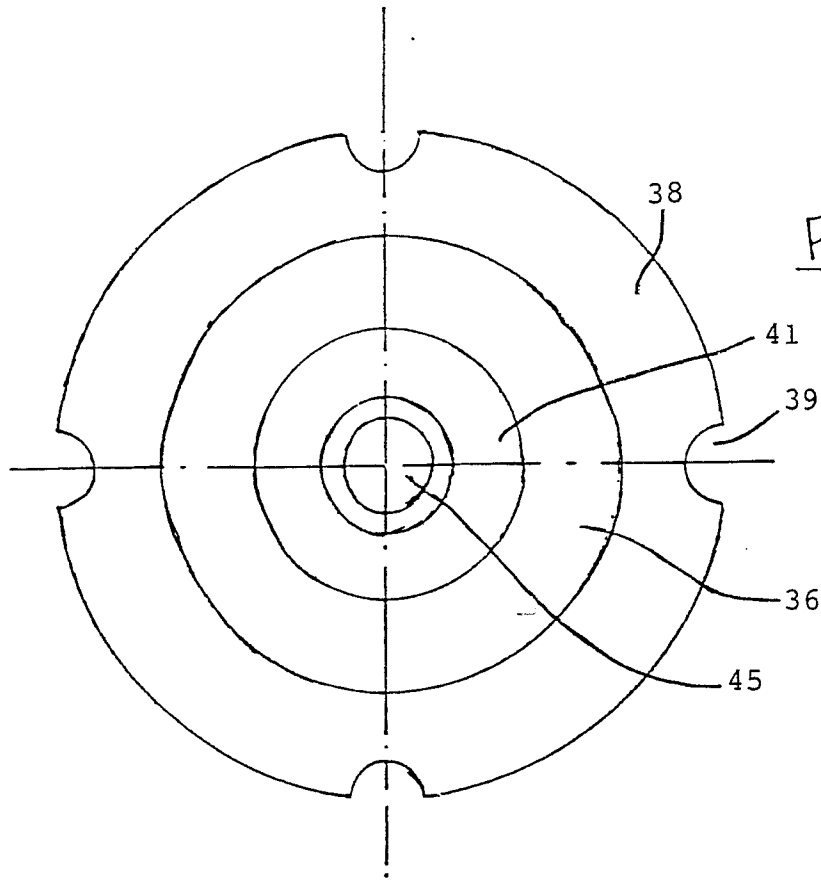
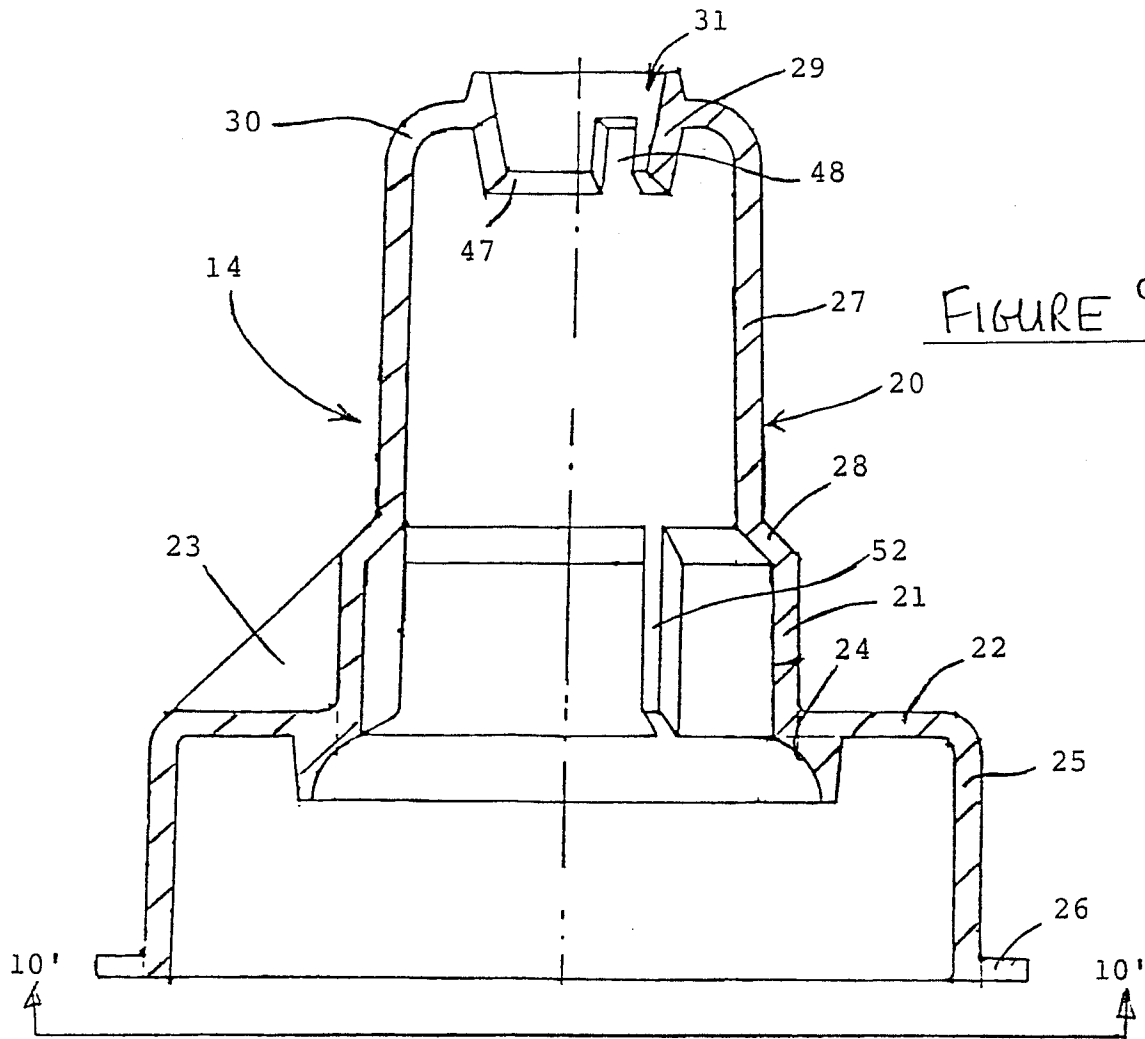

FIGURE 8



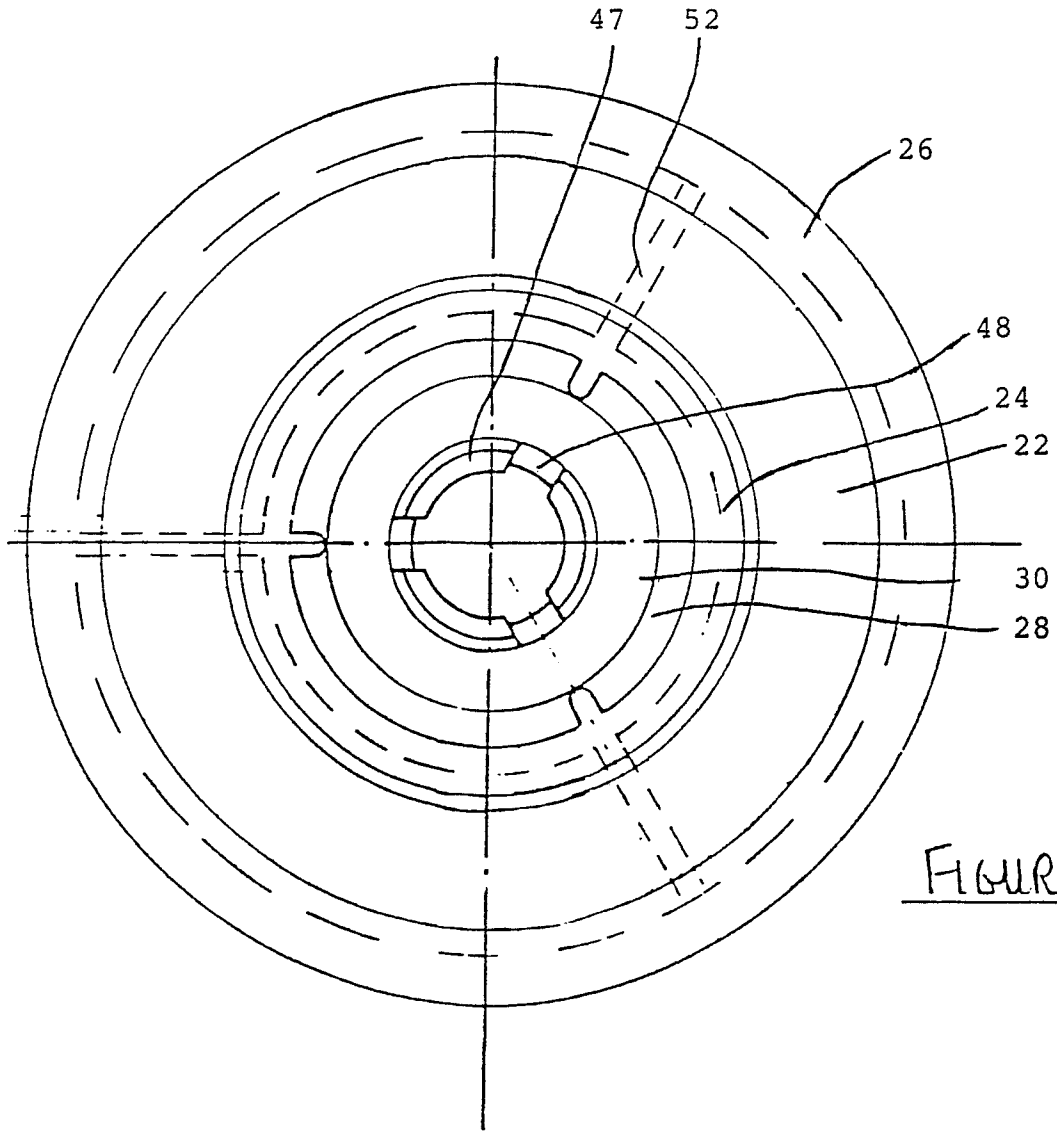

FIGURE 10



DOCUMENTS CONSIDERED TO BE RELEVANT			
Category	Citation of document with indication, where appropriate, of relevant passages	Relevant to claim	CLASSIFICATION OF THE APPLICATION (Int. Cl.4)
X	US-A-3 841 524 (EASTER) * Column 2, lines 56-68; columns 3,4; figures 1-4 *	1-6,10	E 03 D 9/03 A 47 K 5/12
A	---	7	
X	US-A-4 285 074 (LEINBERRY) * Whole document *	1-6,10	
X	EP-A-0 141 687 (BAVAVEAS) * Pages 6-9; figures 1-4 *	1-6,10	
A	US-A-4 294 369 (RACINE) * Whole document *	2,7,8	
			TECHNICAL FIELDS SEARCHED (Int. Cl.4)
			E 03 D A 47 K
The present search report has been drawn up for all claims			
Place of search THE HAGUE		Date of completion of the search 10-12-1987	Examiner HANNAART J.P.
<p>CATEGORY OF CITED DOCUMENTS</p> <p>X : particularly relevant if taken alone  Y : particularly relevant if combined with another document of the same category  A : technological background  O : non-written disclosure  P : intermediate document</p> <p>T : theory or principle underlying the invention  E : earlier patent document, but published on, or after the filing date  D : document cited in the application  L : document cited for other reasons</p> <p>.....  &amp; : member of the same patent family, corresponding document</p>			