

[54] GASOLINE PUMP

[75] Inventors: **Bradley L. Batson**, Hebron; **Alfred C. Evans**; **Robert J. Schiller**, both of Simsbury; **Laird F. Covey**, Easton, all of Conn.

[73] Assignee: **Veeder Industries Inc.**

[**] Term: **14 Years**

[21] Appl. No.: **733,122**

[22] Filed: **Oct. 18, 1976**

[51] Int. Cl. **D20-02**

[52] U.S. Cl. **D52/2 A**

[58] Field of Search **D52/2 R, 2 A, 3 R; 194/3, 13; 222/26-28, 32-36**

[56] **References Cited**

U.S. PATENT DOCUMENTS

D. 199,502	11/1964	Jacobs	D52/2 A
D. 209,918	1/1968	Smith	D52/2 A
D. 232,967	9/1974	Kennedy	D52/2 A
D. 237,101	10/1975	Loy	D52/2 A

OTHER PUBLICATIONS

National Petroleum News - 9/71 p. 36 Gas Pumps at bottom right.

Primary Examiner—Nelson C. Holtje
Attorney, Agent, or Firm—John M. Prutzman

[57] **CLAIM**

The ornamental design for a gasoline pump, substantially as shown and described.

DESCRIPTION

FIG. 1 is a front elevation view of a fuel pump showing a first embodiment of our new design wherein a single-sided display head and a rectangular base are employed;

FIG. 2 is a right side elevation view thereof; FIG. 3 is a rear elevation view thereof; FIG. 4 is a left side elevation view thereof; FIG. 5 is a top plan view thereof; FIG. 6 is a front elevation view of a fuel pump showing a second embodiment of our new design wherein a two-sided display head and a rectangular base are employed; FIG. 7 is a right side elevation view of the embodiment shown in FIG. 6; FIG. 8 is a rear elevation view of the embodiment shown in FIG. 6; FIG. 9 is a left side elevation view of the embodiment shown in FIG. 6; FIG. 10 is a top plan view of the embodiment shown in FIG. 6; FIG. 11 is a front elevation view of a fuel pump showing a third embodiment of our new design wherein a single-sided display head and a cylindrical base are employed; FIG. 12 is a right side elevation view of the embodiment shown in FIG. 11; FIG. 13 is a rear elevation view of the embodiment shown in FIG. 11; FIG. 14 is a left side elevation view of the embodiment shown in FIG. 11; FIG. 15 is a top plan view of the embodiment shown in FIG. 11; FIG. 16 is a front elevation view of a fuel pump showing a fourth embodiment of our new design wherein a two-sided display head and a cylindrical base are employed; FIG. 17 is a right side elevation view of the embodiment shown in FIG. 16; FIG. 18 is a rear elevation view of the embodiment shown in FIG. 16; FIG. 19 is a left side elevation view of the embodiment shown in FIG. 16; and FIG. 20 is a top plan view of the embodiment shown in FIG. 16.

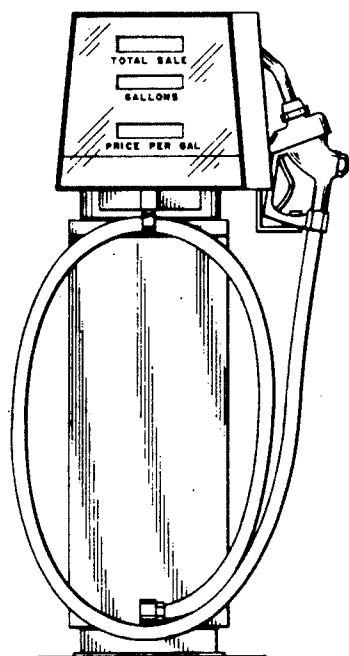

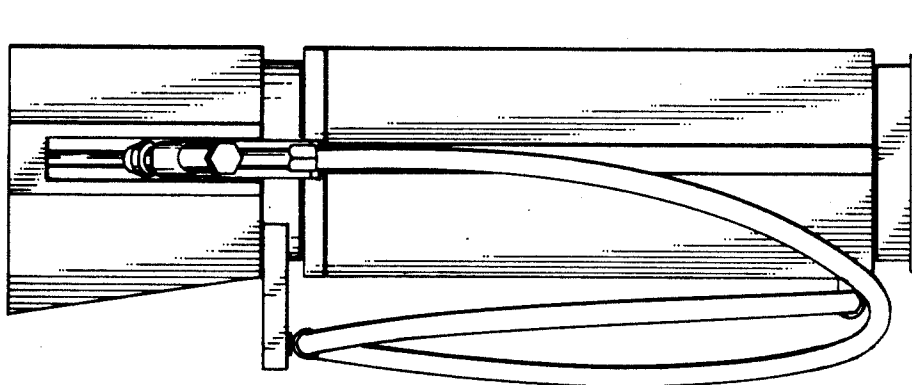

FIG. 2

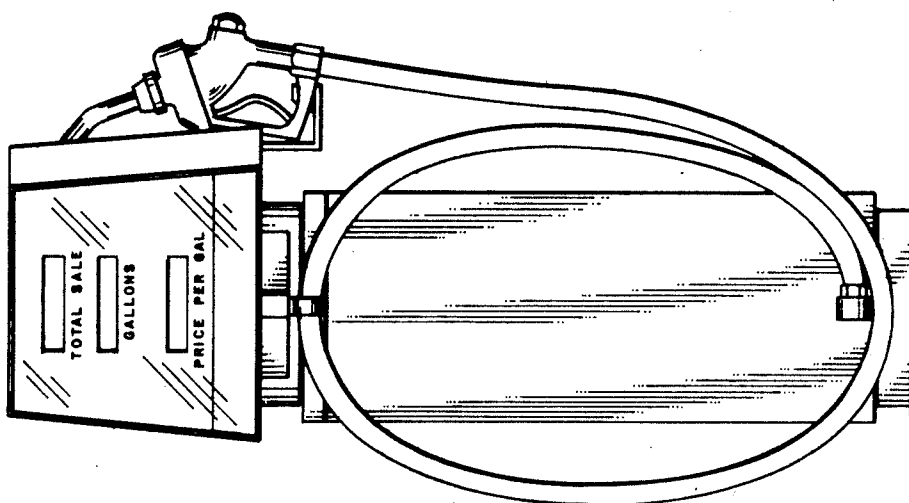

FIG. 1

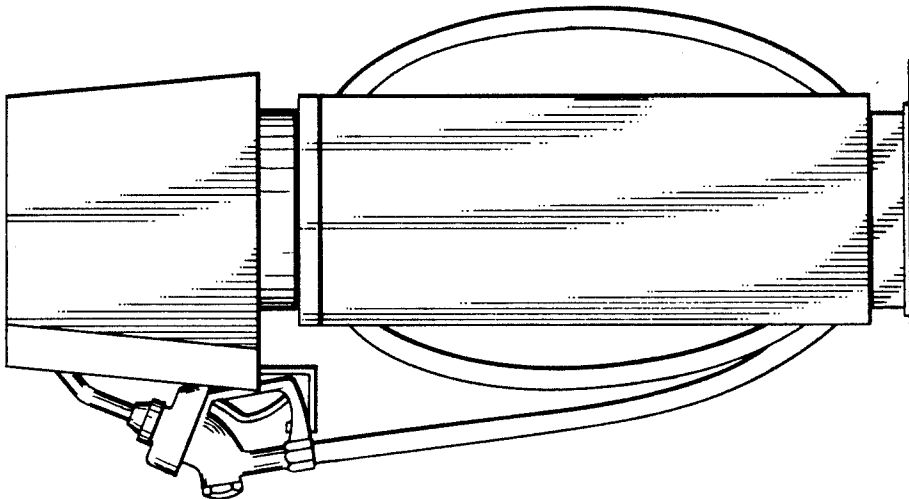

FIG. 3

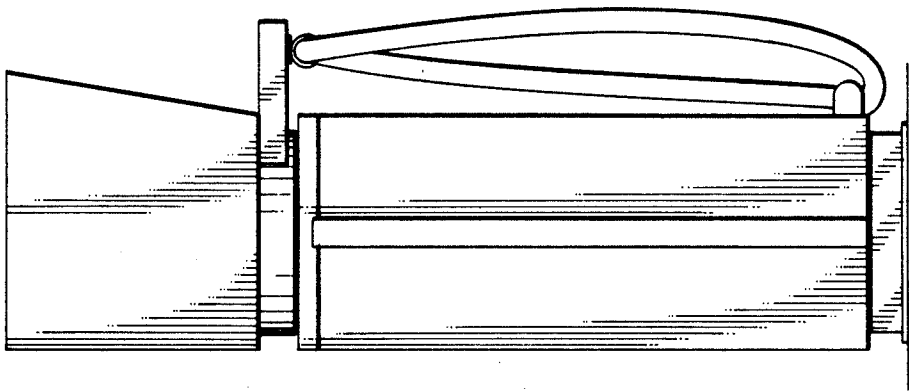

FIG. 4

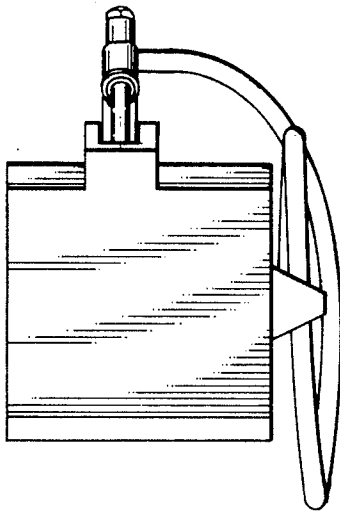

FIG. 5

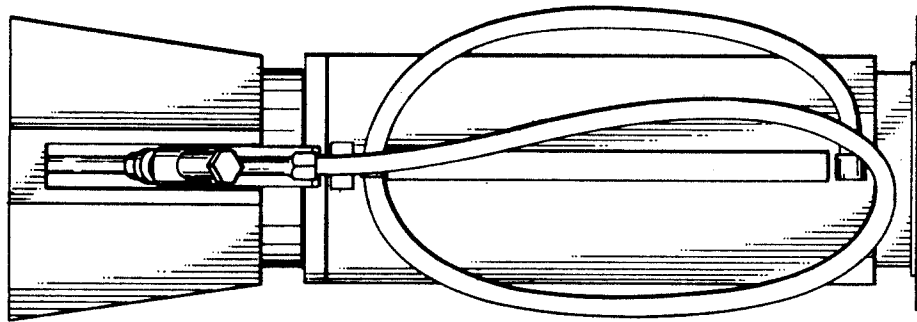

FIG. 7

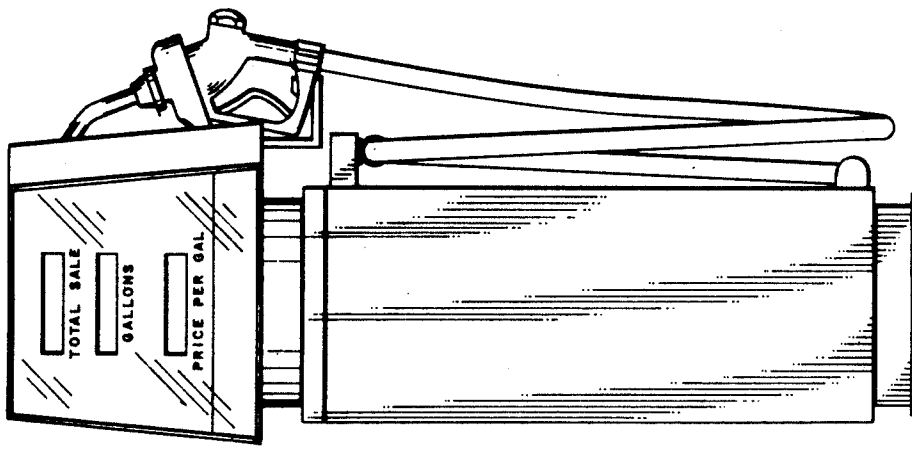

FIG. 6

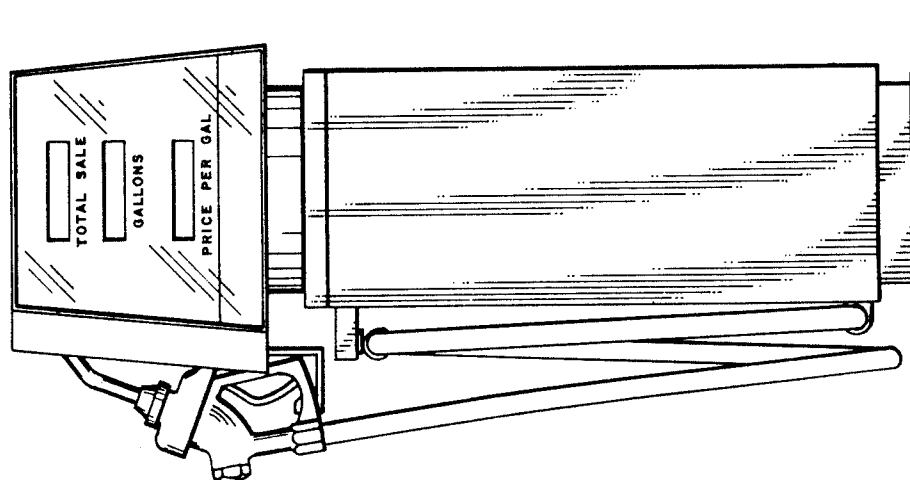

FIG. 8

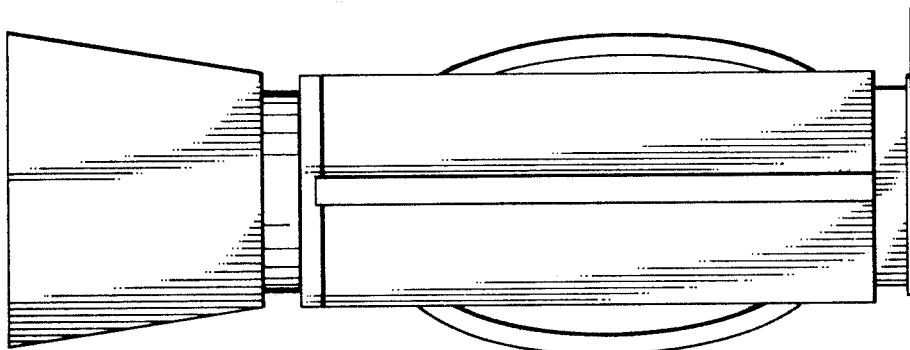

FIG. 9

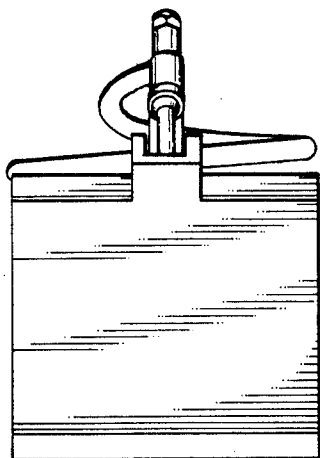

FIG. 10

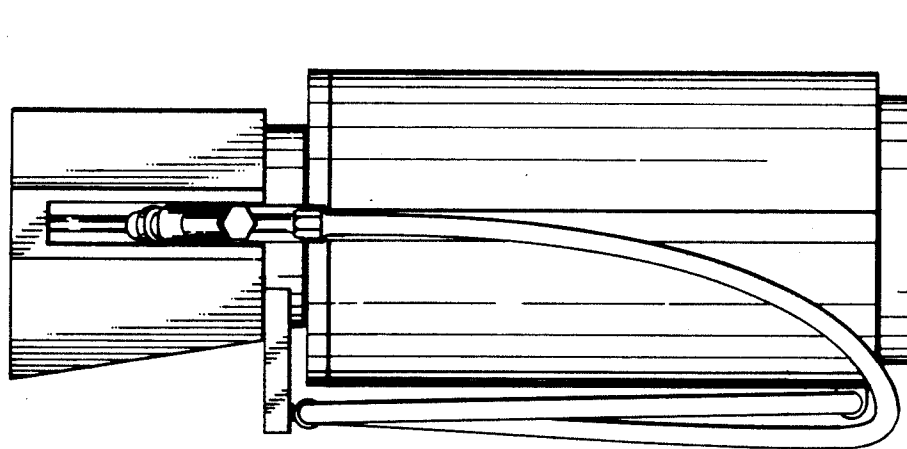

FIG. 12

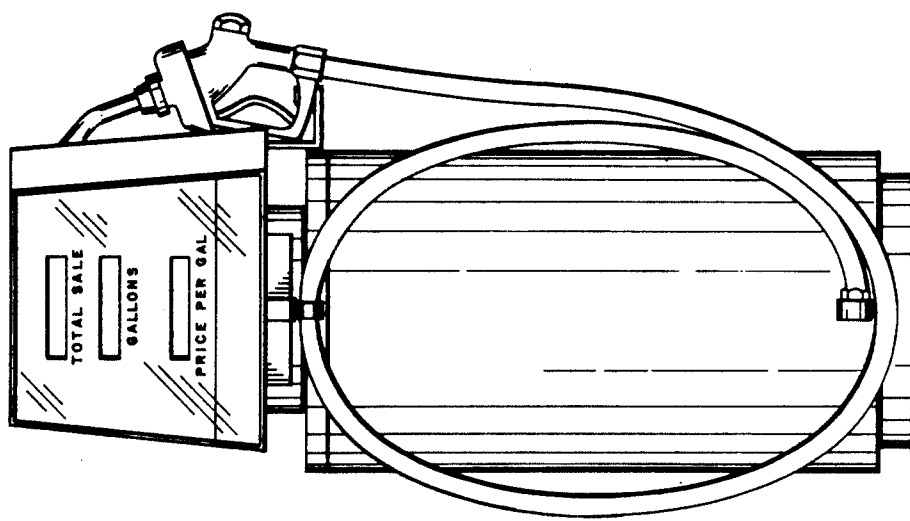

FIG. 11

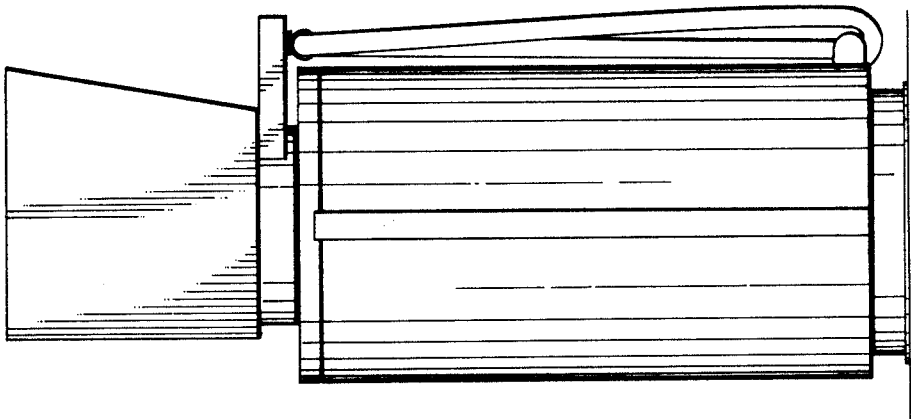

FIG. 13

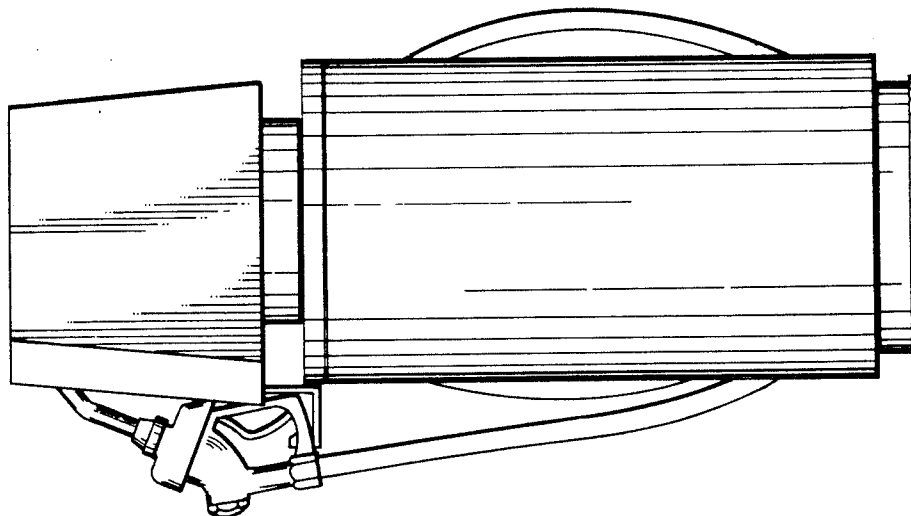

FIG. 14

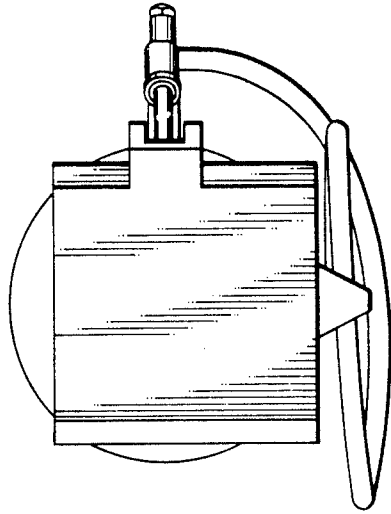

FIG. 15

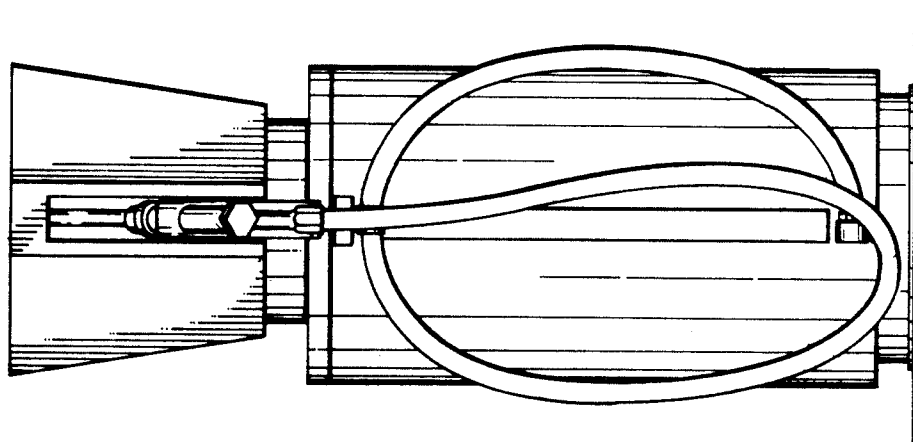

FIG. 17

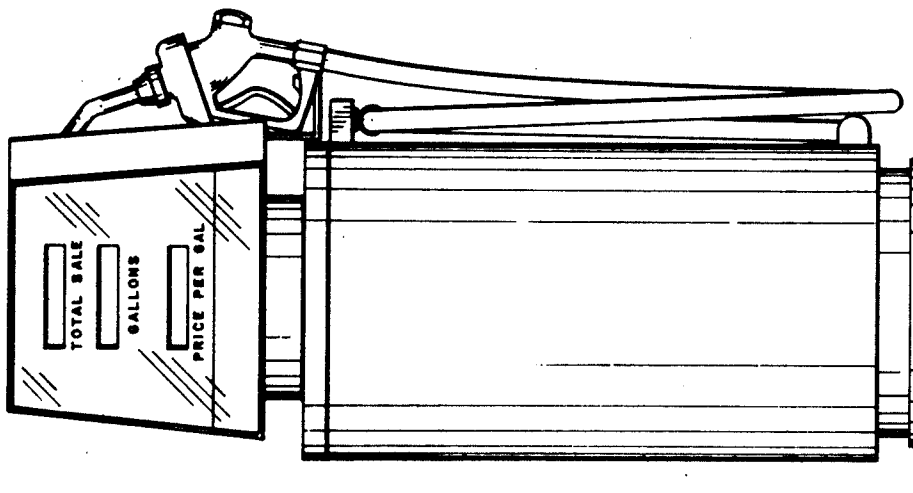

FIG. 16

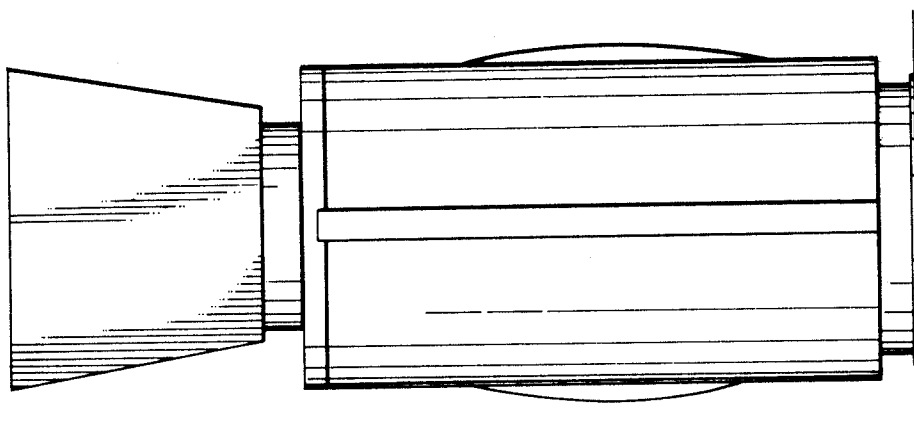

FIG. 19

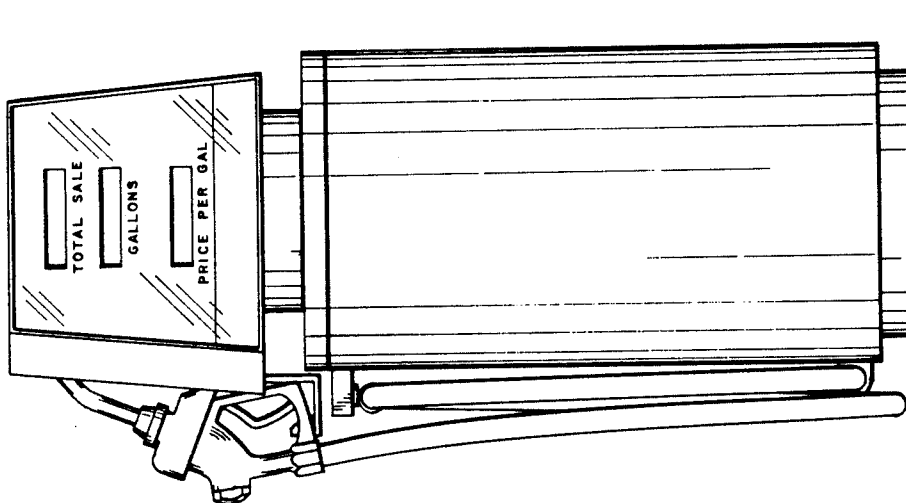

FIG. 18

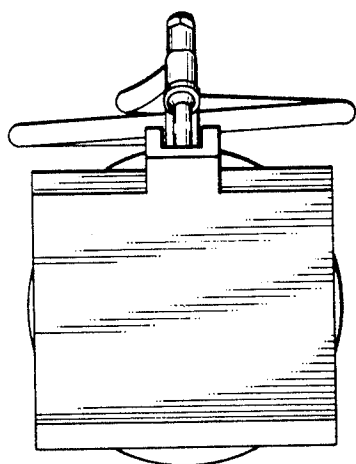

FIG. 20