

[54] SPARK WHEEL

[75] Inventor: **Brian Holl**, South Weymouth, Mass.

[73] Assignee: **The Gillette Company**, Boston, Mass.

[22] Filed: **Aug. 14, 1974**

[21] Appl. No.: **497,382**

[52] U.S. Cl. .... **431/273**

[51] Int. Cl.<sup>2</sup> ..... **F23Q 1/02**

[58] Field of Search ..... 431/141, 142, 151, 152,  
431/254, 273-277

[56] **References Cited**

**UNITED STATES PATENTS**

3,594,108 7/1971 Villarreal-Cueva et al. .... 431/277

**FOREIGN PATENTS OR APPLICATIONS**

555,471 8/1943 United Kingdom ..... 431/273

44,883 11/1910 Austria ..... 431/273

*Primary Examiner*—Carroll B. Dority, Jr.

*Attorney, Agent, or Firm*—Richard A. Wise; Olstein J. Bratlie; Mandel E. Slater

[57] **ABSTRACT**

A spark wheel for use in cigarette lighters is made from a stack of cutting segments or laminations, each having a series of points or teeth and mounted on an arbor, permanently clamped together between a pair of knurled discs or finger pieces. The segments may preferably be so arranged that successive teeth around the periphery of each segment will traverse the flint with each tooth offset slightly with respect to those in front and behind. The toothed segments may be solid flat discs tilted out of a plane perpendicular to the axis of the spark wheel, or they may be deformed discs such as bent washers, split washers or wave washers.

**6 Claims, 8 Drawing Figures**

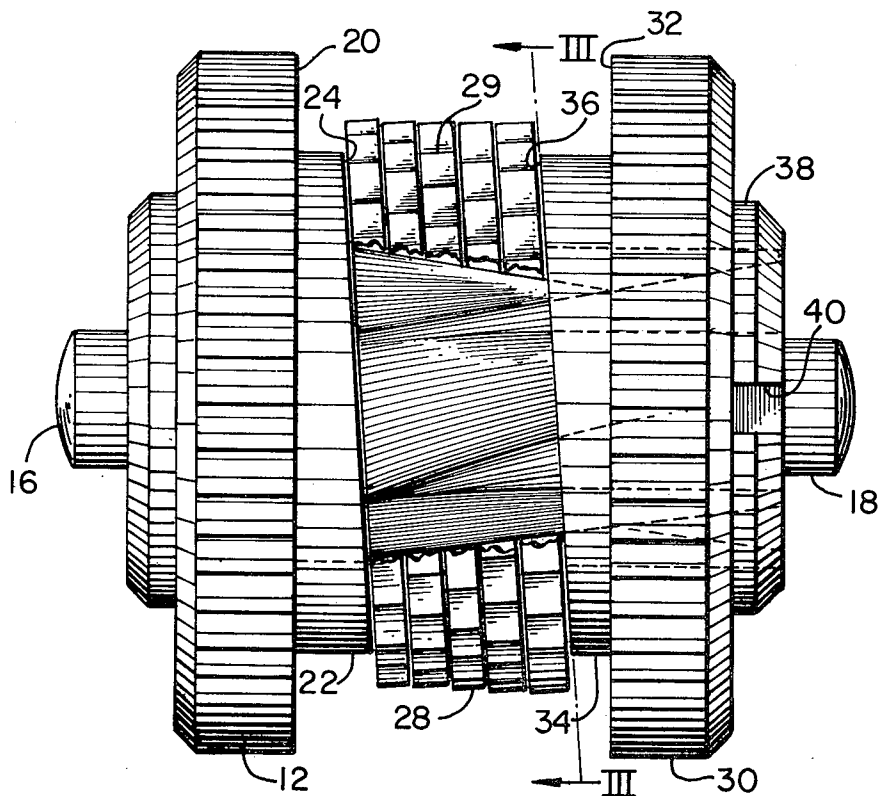

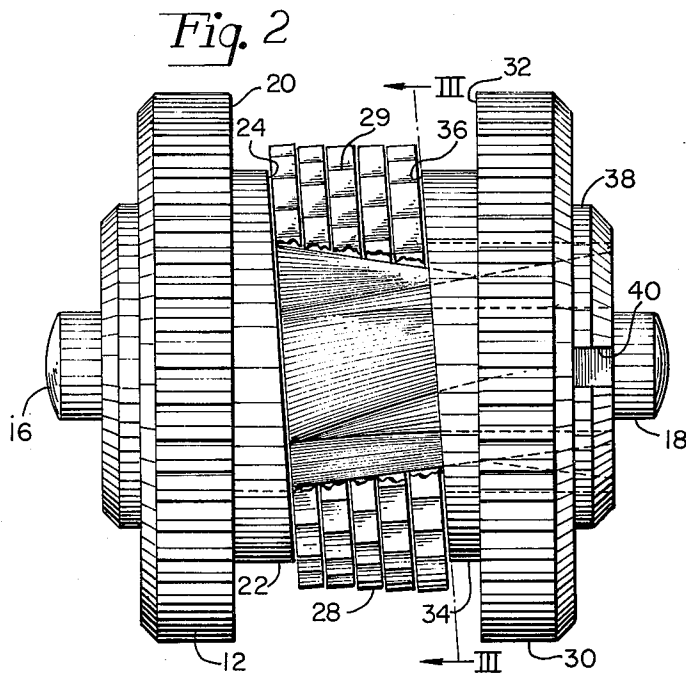
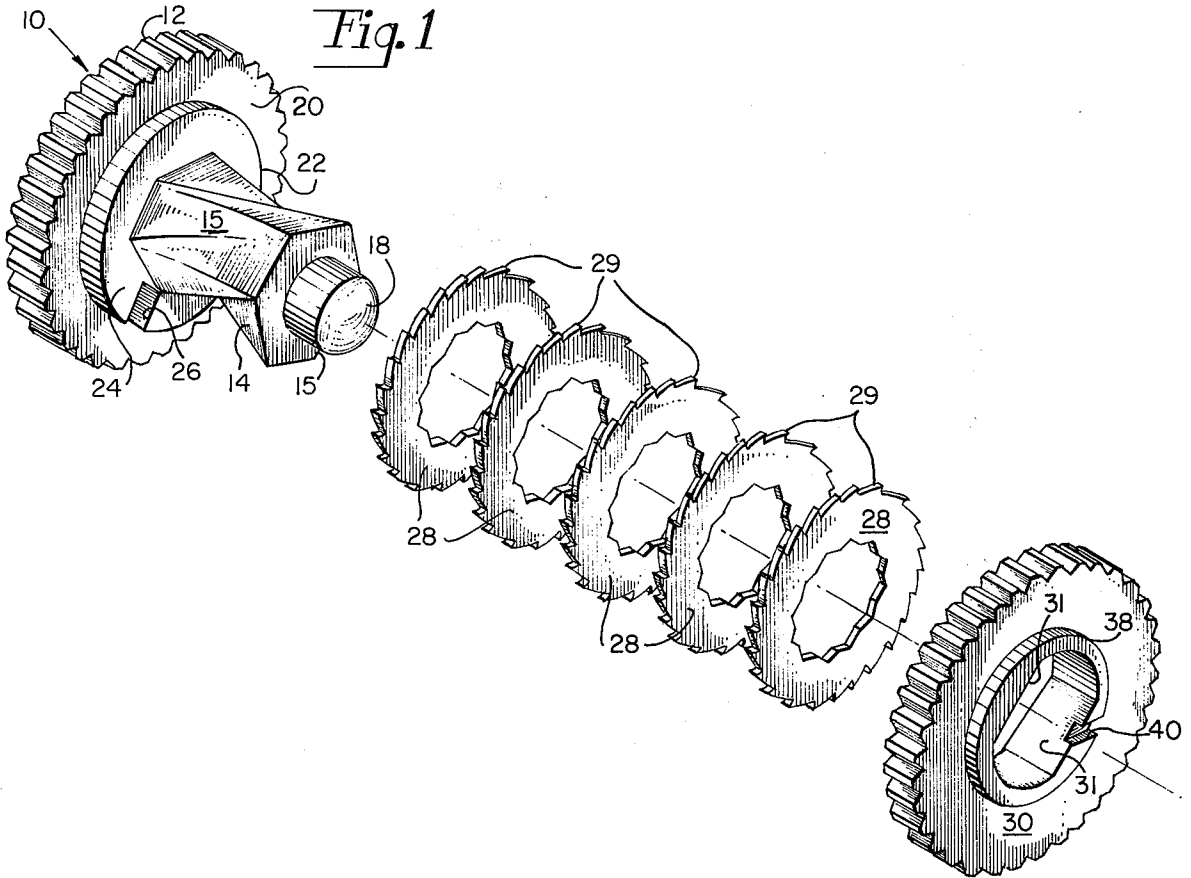

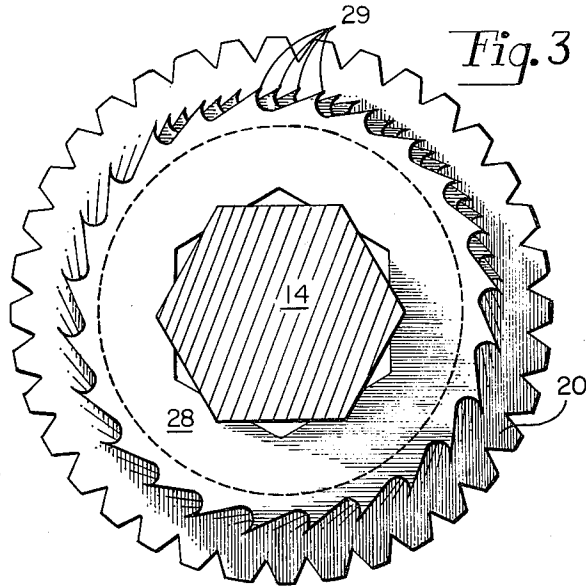

Fig. 4

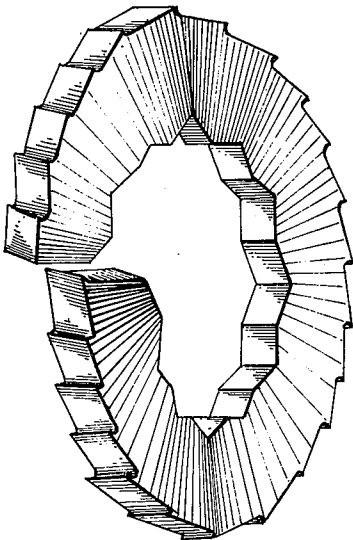

Fig. 6

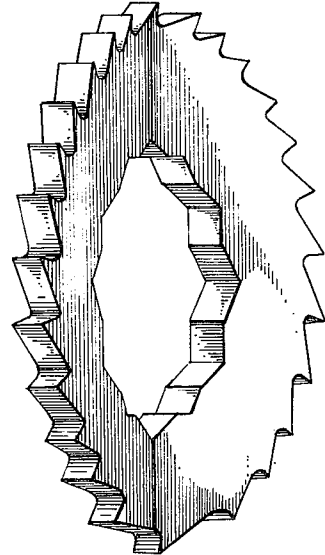

Fig. 8

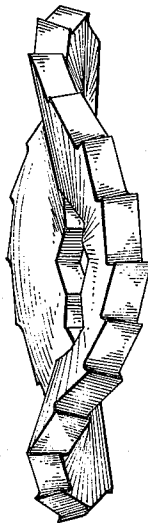
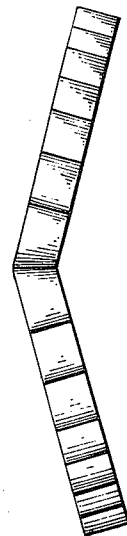

Fig. 5



Fig. 7



# 1

## SPARK WHEEL

### BACKGROUND OF THE INVENTION

#### 1. Field of the Invention

This invention relates to abrasive spark wheels adapted to be rotated against a flint, thereby generating a spark for igniting a fuel, such as used in cigarette lighters and the like.

#### 2. Description of the Prior Art

Spark wheels are usually cylindrical and have an abrasive peripheral surface. The abrasive surface generally comprises a series of hard teeth or ridges which are arranged in a series of rows across the surface and which extend up from the surface in a common inclined direction. The rotation of such a wheel against a flint generates the fine particles which by rapid oxidation create the spark or sparks necessary to ignite a fuel.

Manufacturing processes for toothed spark wheels of the type above described generally involve two stages for the formation of the teeth. In the first stage spiral grooves are formed in the peripheral surface of a wheel, typically in a screw machine. In a second stage another set of grooves is formed in the periphery of the wheel, typically by cold chiseling, along lines generally parallel to the axis of the wheel, the intersecting sets of grooves defining individual sharp cutting teeth. The toothed wheel so formed is then subjected to conventional hardening processes. Although spark wheels made in this manner can provide acceptable sparking performance, such manufacturing processes are generally slow and expensive to carry out.

A less expensive spark wheel may be made from a plurality of toothed discs or segments, as shown in U.S. Pat. Nos. 1,787,530 and 3,594,108. The discs may be die-stamped at low cost and combined in sufficient number to make a composite or laminated spark wheel. However, spark wheels made according to the teachings of the above-cited patents do not produce a spark adequate to insure regular and consistent ignition of the fuel.

### SUMMARY OF THE INVENTION

Accordingly, it is an object of the present invention to provide a spark wheel which can be easily and inexpensively manufactured.

A further object of the invention is to provide a laminated spark wheel that exhibits good sparking performance and long useful life.

With the above objects in view, a feature of the present invention is the provision of a spark wheel comprising a stack of segments or laminations having cutting teeth, mounted on an arbor, and so arranged that, with respect to each such segment, at least some of the teeth are displaced from a plane passing through the segment and perpendicular to the axis of the spark wheel. As a result of this relative displacement of the teeth spaced around the periphery of the laminated spark wheel, a series of scores or scratches will be chased over the surface of the flint, as distinct from a smooth curved face. Put another way, successive teeth around the periphery of each segment traverse the flint with the teeth offset slightly with respect to those in front and behind, with the result that freshly roughened, rather than smooth, flint surface is presented to each tooth.

In a preferred embodiment of the invention the spark wheel includes a plurality of toothed flat washers tilted out of a plane perpendicular to the axis of the spark

2

wheel. In order to hold the washers at an angle with respect to the axis of the spark wheel, a spark wheel assembly is provided which, in addition to an arbor and washers mounted thereon, further includes a pair of finger pieces and a pair of stub shafts for rotatably mounting the assembly in a cigarette lighter. The finger pieces have inclined inner faces which cooperate to hold the washers in the assembly at the desired angle. The arbor in a preferred embodiment has a hexagonal cross section, and the washers mounted thereon are provided with a "double hex"-shaped hole to secure the toothed washers against relative rotation with respect to the arbor, in addition the arbor is twisted along its axis in order that the teeth on each segment are angularly offset from the teeth on neighboring segments.

In further embodiments of the invention the desired effect of having successive teeth around the periphery of a segment traverse the flint with the teeth offset with respect to those in front and behind, may be realized by providing cutting segments in the form of deformed discs such as bent washers, split washers or wave washers.

The above and other features of the invention, including various novel details of construction and combinations of parts, will now be more particularly described with reference to the accompanying drawings and pointed out in the claims. It will be understood that the particular device embodying the invention is shown by way of illustration only and not as a limitation of the invention. The principles and features of this invention may be employed in various and numerous embodiments without departing from the scope of the invention.

### BRIEF DESCRIPTION OF THE DRAWINGS

Reference is made to the accompanying drawings in which are shown illustrative embodiments of the invention from which its novel features and advantages will be apparent.

FIG. 1 is an exploded perspective view of one form of spark wheel assembly illustrative of an embodiment of the invention;

FIG. 2 is an elevational view, partially in section, of the spark wheel assembly shown in FIG. 1;

FIG. 3 is a sectional view taken along line III—III of FIG. 2;

FIGS. 4 and 5 are perspective and elevational views, respectively, of another embodiment of the invention;

FIGS. 6 and 7 are perspective and elevational views, respectively, of still another embodiment of the invention; and

FIG. 8 is an elevational view of yet another embodiment of the invention.

### DESCRIPTION OF THE PREFERRED EMBODIMENTS

Referring to FIGS. 1-3, it will be seen that the illustrative spark wheel assembly includes a combination finger piece-and-arbor 10 having a knurled finger piece portion 12, a twisted arbor 14 of hexagonal cross-section and a pair of sub shafts 16 and 18. The twisted hexagon arbor 14 is provided with a single pair of opposed flat surfaces parallel with the center line of the spark wheel over the twisted configuration, one of which is shown at 15; the flat surfaces aid in orienting a second finger piece as will be shown. Finger piece portion 12 has an inner planar radial face 20 perpen-

dicular to the axis of the spark wheel. A cylindrical hub 22 extends from face 20 and has an inclined surface 24 at an angle with respect to the face 20 of the finger piece portion. An angle of only a few degrees is sufficient to achieve the desired effect. A radially extending key slot 26 is provided in the hub 22 for orientation purposes, as will presently be described.

Mounted on arbor 14 are a number of identical steel discs or segments 28, each disc having a plurality of cutting teeth 29 and a central hole, the surface of which is provided with twelve wedge-shaped notches for securely positioning the discs on the arbor. The cutting discs may conveniently be die-stamped and then hardened by conventional means. In making a spark wheel for a cigarette lighter, five discs of 0.020 inch thickness or six discs of 0.016 inch thickness may conveniently be used to produce spark wheels of conventional size, but varying numbers of discs of different thicknesses may also be used. Completing the assembly is a second knurled finger piece 30 having a central opening provided with a pair of opposed flat surfaces 31 adapted to be press fitted onto the arbor. Finger piece 30 also has an inner face 32 with a cylindrical hub portion 34 having an inclined surface 36, which is at the same angle with respect to the inner face 32 of the finger piece 30 as the inclined surface 24 is to the inner face 20 of finger piece portion 12. A cylindrical hub 38 on the outside of finger piece 30 is provided with a radially extending key slot 40 for orientation purposes. It will be appreciated that since the key slots 26, 40 are merely for orientation in assembling the parts; the slots may be provided with various configurations and/or positioned differently on the parts.

In order to put the spark wheel assembly together, cutting segments 28 are placed onto arbor 14, and finger piece 30 is positioned loosely over stub shaft 18 at the end of the arbor. The key slots 26 and 40 serve as guideways for keying elements in an assembly machine so that the combination finger piece-and-arbor 10 and finger piece 30 are rotated relative to each other until the inclined surfaces 24 and 36 line up in parallel relationship, which also brings into alignment the pair of flat surfaces 31 of finger piece 30 with the pair of flat surfaces 15 on arbor 14. Finger piece 30 is then forcibly press fitted onto the arbor 14, the cooperating pairs of flat surfaces 15 and 31 serving to secure the desired relationship of the parts as a unit. The cutting segments are thereby locked in position at an angle with respect to a plane perpendicular to the axis of the spark wheel assembly.

It will be seen that with respect to a stationary flint positioned against the cutting segments successive teeth around the periphery of each cutting segment are offset slightly with respect to those in front and behind, so that each tooth would strike the flint in a slightly different position, enhancing the sparking effectiveness of the spark wheel. Furthermore, as a result of the twisted

configuration of the arbor, each toothed disc is angularly displaced from its neighbors, as best shown in FIG. 3, with the result that teeth on adjacent discs do not line up along lines generally parallel to the axis of the spark wheel assembly, the angular displacement producing the effect of a great number of discrete sharp cutting teeth. This further enhances the sparking effectiveness of the wheel.

In further embodiments of the invention is laminated spark wheel assembly of similar effect may be made up from a plurality of toothed segments based on deformed discs such as a split washer, as shown in FIGS. 4 and 5, or a bent washer, as shown in FIGS. 6 and 7, or a wave washer, as shown in FIG. 8. The use of deformed discs avoids the need to provide means for tilting the segments out of a plane perpendicular to the spark wheel axis. It is necessary only that the segments be of self-supporting strength so that they won't flatten out when subjected to the forces involved in securing the assembly together.

It is to be understood that the present invention is by no means limited to the particular construction herein disclosed and/or shown in the drawings, but also comprises any modifications or equivalents within the scope of the disclosure.

Having thus described my invention, I claim:

1. A spark wheel comprising a stack of segments having cutting teeth, with at least some, but not all, of the teeth on each segment lying outside a plane passing through that segment perpendicularly to the axis of said stack.

2. A spark wheel as defined in claim 1, in which the teeth on each segment are angularly offset with respect to the teeth on a neighboring segment.

3. A spark wheel as defined in claim 1, and further including an arbor on which said segments are mounted, said segments having a central opening for fitting on said arbor, and means to hold said segments at an angle with respect to a plane perpendicular to said axis.

4. A spark wheel assembly comprising an arbor of non-circular cross section; a plurality of toothed flat discs mounted on said arbor, each of said discs having a central opening including means engaging said arbor restraining said discs from rotation relative to said arbor; and a pair of finger pieces mounted on the ends of said arbor, said finger pieces having inner faces parallel to each other and inclined to the axis of said arbor, whereby said toothed discs are held in tilted relationship to a plane perpendicular to said axis.

5. A spark wheel assembly as defined in claim 4, and further including a stub shaft at each end of said arbor for rotatably mounting said spark wheel assembly.

6. A spark wheel assembly as defined in claim 4, wherein said arbor is in twisted configuration along said axis.

\* \* \* \* \*