

(12) STANDARD PATENT
(19) AUSTRALIAN PATENT OFFICE

(11) Application No. **AU 2017202015 B2**

(54) Title
USABLE CABIN SPACE OF A MOTOR VEHICLE

(51) International Patent Classification(s)
B60P 3/42 (2006.01) **B60N 2/36** (2006.01)
B60N 2/30 (2006.01) **B60N 2/90** (2018.01)

(21) Application No: **2017202015** (22) Date of Filing: **2017.03.27**

(30) Priority Data

(31) Number	(32) Date	(33) Country
00739/16	2016.06.09	CH

(43) Publication Date: **2018.01.04**

(43) Publication Journal Date: **2018.01.04**

(44) Accepted Journal Date: **2018.06.14**

(71) Applicant(s)
General Dynamics European Land Systems - Mowag GmbH

(72) Inventor(s)
MERZ, Lukas;MILDNER, Lars;SCHAEFFER, Csaba

(74) Agent / Attorney
**P L BERRY & ASSOCIATES, IP Gateway Patent & Trademark Attorneys P O Box 1321,
Springwood, QLD, 4127, AU**

(56) Related Art
US 4005898 A

Abstract

5 The useful cabin space of a motor vehicle for transporting personnel and materials has a cabin frame (2) intended for a removable cabin shell and formed by longitudinal beams and transverse beams, and has a cabin interior construction with two rows of
10 seats running opposite one another in the direction of travel and laterally above a central vehicle floor. These have seat bench panels (59) and backrests (56), which are connected to one another via a first pivot axis (79). The seat bench panels (5) together with the backrests (56), forming a loading surface, can be pivoted inwardly about a second pivot axis (65) so that the usable cabin space can be converted into a loading
15 space accessible from the side for material transport. Seat bodies (55) each intended for a person are provided on the seat bench panels (59) and are each associated with a backrest (56) having seat belts (58) and a headrest (57). Each backrest (56) can be lowered towards the seat body (55) by means of a lowering mechanism (18) and is
20 locked to side beams (25) detachably anchored in the cabin frame (2).

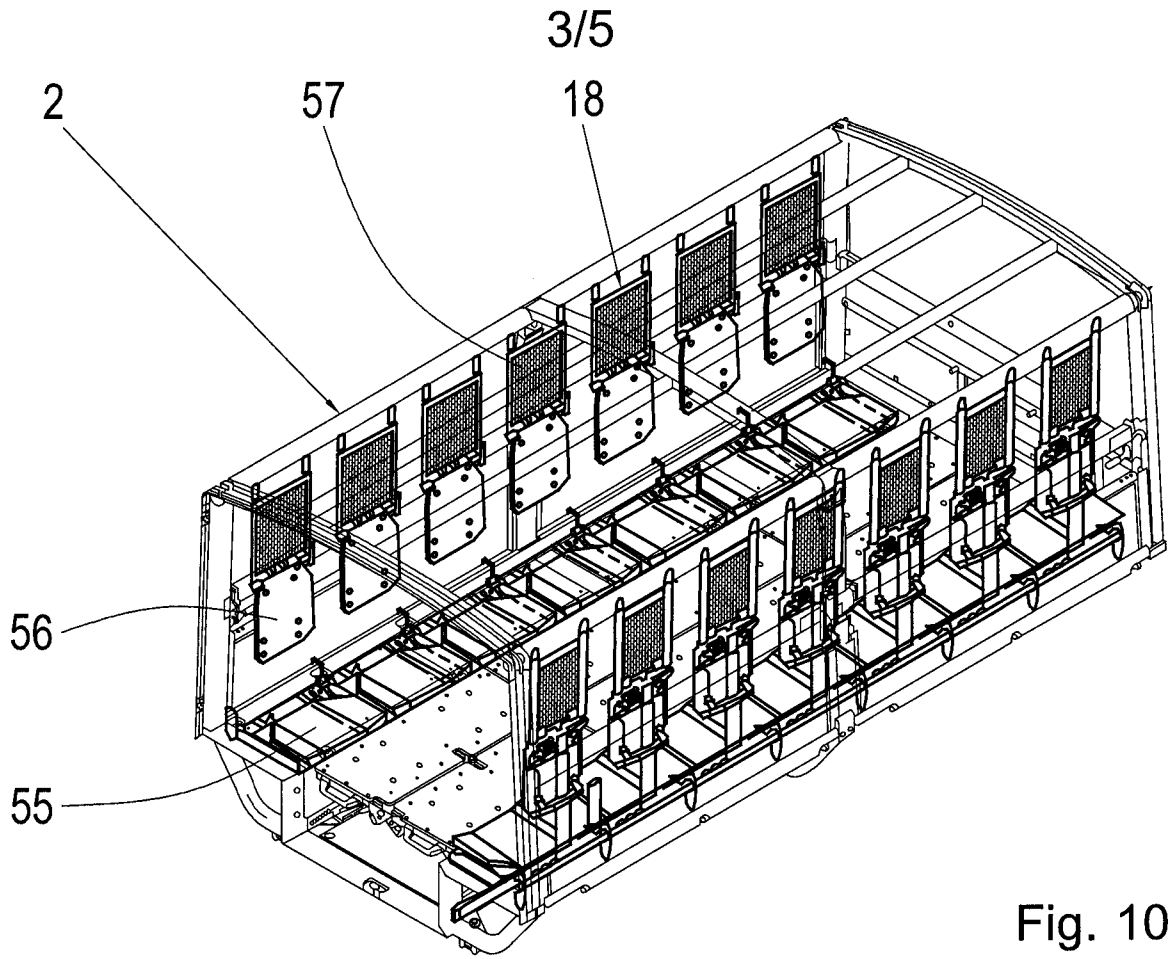

Fig. 10

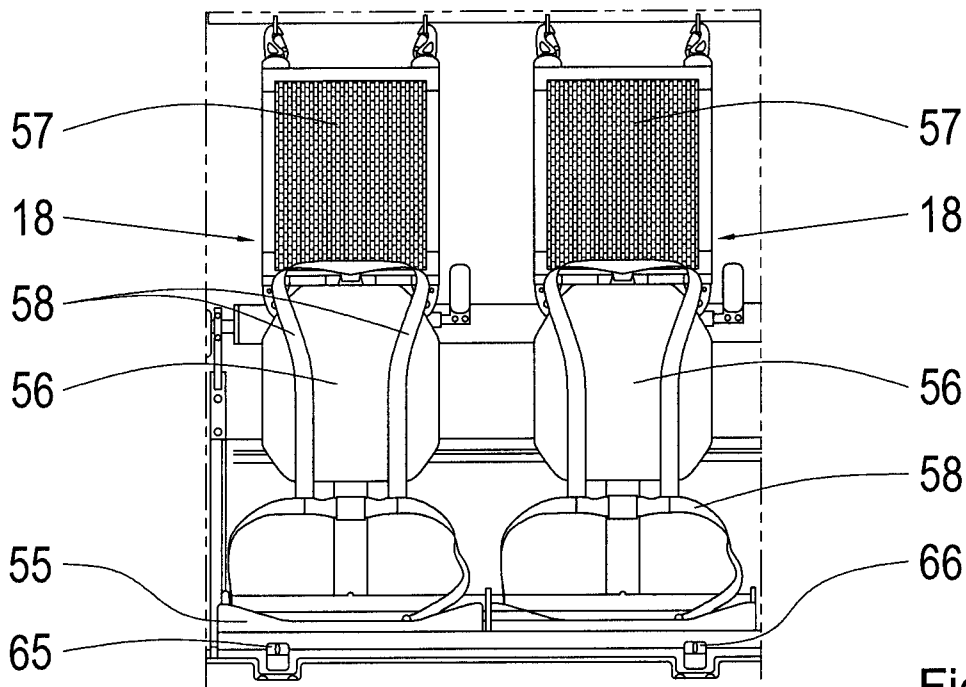

Fig. 11

Usable cabin space of a motor vehicle

The invention relates to a usable cabin space of a motor vehicle for transporting personnel and materials, comprising a cabin frame intended for a removable cabin shell and formed by longitudinal beams and transverse beams, and comprising a cabin interior construction, which has two rows of seats running opposite one another in the direction of travel and laterally above a central vehicle floor, with seat bench panels and backrests, which are connected to one another via a first pivot axis, wherein the seat bench panels together with the backrests, forming a loading surface, can be pivoted inwardly about a second pivot axis so that the usable cabin space can be converted into a loading space also accessible from the side.

A usable cabin space of this type is known by US4005898 or earlier military vehicles bearing the name MOWAG DURO 1 developed by the applicant, from a time when a seat bench and a narrow (in the vertical direction) backrest supported on a side loading flap were acceptable for transporting personnel. Such a useful cabin space on the other hand has the advantage that, once its seat benches have been folded down to form a loading surface and its side loading flaps have been lowered, it can be loaded in a simple way from two sides, for example by means of forklift trucks.

In a newer embodiment of a usable cabin space developed by the applicant and known through WIKIPEDIA as MOWAG DURO IIP, this advantage had to be omitted in the interest of passenger protection. For the material transport, individual seat bodies indeed can be pivoted towards the cabin side wall and can be locked there so as to form a loading surface; however, this results merely in an uneven, laterally closed loading space, which is thus accessible only from the end of the vehicle.

For civilian vehicles, it is additionally known in general that a seat backrest can be pivoted forwards in order to form a loading surface. Examples of this are presented in US20110148146, WO9917953, DE102004041734 or WO9947378.

The object of the invention is to form a useful cabin space corresponding to the introductory part of claim 1 and thus provide the advantage also of loading capability from the side, such that a transport of personnel with high seated comfort and high safety is ensured. This object is solved in accordance with the invention on the basis of the characterising features of claim 1. Advantageous embodiments of the invention are the subject matter of the dependent claims.

The invention will be explained in greater detail hereinafter with reference to an exemplary embodiment illustrated in the drawings, in which:

5 Fig. 1 shows a perspective illustration, simplified by the omission *inter alia* of seat belts, of a useful cabin space with its arrangement of individual seats and with the collapsed position of its individual seats, forming a loading surface, before side loading flaps are folded down and middle, lateral framework beams are removed.

Fig. 2 shows a cross-sectional illustration of a hook engagement at the upper end of a vertical beam of the useful cabin space,

10 Fig. 3 shows a perspective partial illustration in the locking region between a vertical beam and a side beam of the useful cabin space according to Fig. 1, in an initial phase of an engagement movement,

Fig. 4 shows a vertical section of the locking region according to Fig. 3,

Fig. 5 shows an illustration corresponding to Fig. 3 in an end phase of the locking,

Fig. 6 shows a vertical section of the locking region according to Fig.5,

15 Fig. 7 shows a front view in the end region of a side beam of the useful space cabin according to Fig.1, said end region being intended for locking,

Fig. 8 shows a detailed view in the region of a cam receptacle according to Fig. 3 or Fig. 4,

20 Fig. 9 shows a vertical section in the engagement region between locking cam and the cam receptacle according to Fig. 8,

Fig. 10 shows a schematic perspective illustration of the useful cabin space with two rows of seat units in the usage position and in a simplified illustration,

Fig. 11 shows a front view of two seats of a row of seats according to Fig.10,

25 Fig. 12 shows a cross-sectional illustration of the useful cabin space with belted-in passengers,

Fig. 13 shows a cross-section through a seat unit according to Fig. 12 with a lowered backrest,

Fig. 14 shows a cross-section through the seat unit according to Fig. 13 with an intermediate position of the backrest, folded forwards,

Fig.15 shows a cross-section through the seat unit according to Fig. 13 and Fig. 14 in an end position of a folding motion forming a loading surface, and

Fig.16 shows a rear-side view of a group of seat units of the rows of seats according to Fig.10.

5 In accordance with the illustration in Fig. 1, the useful cabin space 1 has a cabin frame 2 with a transversely running front frame 3, a middle frame 4, and an end frame 5, which are rigidly connected to one another via continuously longitudinally running roof beams 6 to 10 and a base frame 11 intended to be secured to the chassis of a motor vehicle, for example by welding.

10 Compared to previously known useful cabin spaces of the type described in the introduction, new, detachably anchored lateral vertical beams 12, 13 of the middle frame 4 together with longitudinally running side beams 14 to 17 detachably anchored thereto provide the cabin frame 2 with the necessary strength and dimensional rigidity, even with use in territories where there is a risk of the vehicle tipping and rolling over,
15 so as to also be able to absorb the inertia forces which can be introduced via new seat units 18 having seat belts as described hereinafter.

In order to insert and lock the lateral vertical beams 12, 13 in the cabin frame 2, said beams have an engagement hook 19 at one end, in accordance with the illustration in Fig. 2. These engagement hooks 19 are each hooked in place in an interlockingly
20 engaged manner over a round pin 20 of a hook receptacle 21, these being provided on the middle of respective roof beams 6, 10 of the cabin frame 2. This results in an interlockingly engaged and frictionally engaged locking when the vertical beams 12, 13 are pivoted laterally into the hook receptacle 21, on account of the dimensioning of the engagement hook 19 and the shaping of an inner profiling 22 of the hook receptacle
25 21. The lower end of the vertical beams 12, 13 is detachably secured to the base frame 11 by means of screws 23, 24.

In order to lock the longitudinally running side beams 14 to 17, which serve to hold seat units 18, in a detachable yet shake-proof manner, a cam receptacle 29 illustrated in Fig. 3 to 6 and Fig. 8 and 9 is provided in the middle, lateral vertical beams 12, 13
30 and in the vertical beams 25 to 28 of the frames 3 to 5. This cam receptacle serves for the interlocking and frictional engagement of a locking cam 31 provided at the end on a journal 30 of each of the side beams 14 to 17.

In order to produce the interlocking and frictional engagement between the locking cams 31 of the side beams 14 to 17, which locking cams are provided at the ends of said beams and are illustrated in Fig. 3 to 5 and Fig. 8 to 10, and a cam receptacle 29, they have a V-shaped forked portion 32 on their lower side in the engaged position, corresponding to the illustrations in Fig. 8 and Fig. 10, which forked portion sits in a rider-like manner with its two limbs 33, 34 on a detent wedge 35 of the cam receptacle 29, corresponding to the illustration in Fig. 10. In addition, the detent wedge 35 is delimited outwardly by a crossmember 36 visible in Fig. 5 and Fig. 9, such that the forked locking cam 31 engages in the cam receptacle 29 from behind.

10 A further interlocking and frictional engagement of the locking cam 31 in the cam receptacle 29 is produced between a detent block 37 provided above the detent wedge 35 in the cam receptacle 29 and a detent recess 38 of the locking cam 31, which detent recess is adapted to the shape of said detent block.

When producing the interlocking and frictional engagement of the locking cam 31 in the cam receptacle 29 profiled inwardly in the previously described way, a rotational movement about the longitudinal axis of the associated side beam 14 to 17 is necessary once said locking cam 29 has been introduced laterally into the cam receptacle 29. The illustration according to Fig. 3 in this regard shows the initial, pivoted-back angular position of the side beam 14 to be locked, whereas Fig. 5 shows the end position.

In order to secure the locking in the cam receptacle 29, a first gearwheel sector 39 having an eccentric set of teeth 40 is provided on the journal 30 between the locking cam 31 and the end of the side beam 14, which gearwheel sector is in toothed engagement with a second, likewise eccentric gearwheel sector 42 secured at the end of a locking lever 41 for conjoint rotation. Here, the rotary mounting of the locking lever 41 and the rotary mounting of the side beam 14 are provided in bearing bores 43, 44 of a common flat bar 45.

By pivoting the locking lever 41 from the laterally protruding position according to Fig. 4 into a lower position running parallel to the flat bar 45 in accordance with the illustration in Fig. 6, a shake-proof tensioning is provided on account of the eccentricity of the aforementioned toothed engagement of the gearwheel sectors 39 and 42, which tensioning counteracts a back-rotation of the side beam 14 and thus release of the cam engagement within the cam receptacle.

For a further securing of the engagement position of the side beam 14, the locking lever 41 has an axially displaceable handle 46 similar to a crank handle, such that a handle pin at the end (not illustrated) finds a position of engagement in an opening 47 in a rod profile 48 fixedly connected to the flat bar 45, for example by welding, and thus secures said rod profile.

The rod profile 48 preferably connects the side beam 14 to a side loading flap 50 to 53 conventional for heavy goods vehicles, such that these loading flaps can be pivoted downwardly jointly about lower hinge joints 54 in order to open the usable cabin space 1.

In order to be able to convert the usable cabin space 1, starting from the state with seat units 18 arranged in the usage position according to Fig. 10, into a state corresponding to the illustration in Fig. 1 suitable for material transport, the seat units 18 equipped with a cushioned seat body 55, a backrest 56, and a headrest 57 and additionally having three-point seat belts 58 can be moved starting from their position according to Fig. 12 in a number of phases into a position according to Fig. 15.

In order to attain here a level loading surface corresponding to the illustration in Fig. 1, as well as simple handling, the seat bodies 55 of the seat units 18 are each secured together with at least one adjacent seat unit 18 on a common seat bench panel 59 to 64. These seat bench panels 59 to 64 each have hinges 65 to 75 on their front edge turned towards the middle of the cabin (Fig. 1), such that they, together with their associated seat units 18, can be pivoted inwardly about the hinge axes in such a way that they form the level loading surface shown in the illustrations of Fig. 1 and Fig. 15.

So that this inward pivoting of the seat bench panels 59 to 64 together with the seat units 18 consisting fundamentally of seat body 55, backrest 56, seat belts 57 and headrest 58 is possible, said seat bench panels can be moved, starting from the position according to Fig. 11 or Fig. 12, into the position according to Fig. 14 and consequently also into the end position according to Fig. 15 or Fig. 1.

These movements of the aforementioned elements 55 to 58 of the seat units 18 are made possible by the embodiment thereof described hereinafter and by a detachable securing to the cabin frame 2.

In accordance with the illustrations in Fig. 16, each backrest 56 is secured to a T-shaped seat-back holder 77 *inter alia* via a transverse strut 76, the transverse beam 78 of said seat-back holder being connected to a seat body frame 80 by means of a

pivot spindle 79. At both ends of the transverse beam 78 there is a detent hook 81 provided, which is engaged with a detent pin 82, which is provided in a recess (not illustrated) in a floor-side beam 83 of the cabin frame 2.

5 In addition, the seat-back holders 77 and thus the backrests 56 are detachably anchored to the side beams 14 to 17 of the cabin frame 2. For this purpose, a securing tab 84 for each seat-back holder 77 is welded to the side beams 14 to 17, with a sliding bolt 86 engaging in the receiving hole in said securing tabs, which bolt can be actuated by means of a handle 85 and is guided on the seat-back holder 77.

10 The seat-back holder also has a lowering mechanism in which the vertical beam 87 of the T-shaped seat-back holder 77 is embodied as a telescopic tube that is square in cross-section. This lowering mechanism, once the sliding bolt 86 has been displaced and therefore the securing of the backrest 56 in question to the cabin frame 2 has been released, enables said backrest to be lowered starting from the usage position according to Fig. 12 into a position according to Fig. 13, from which it can be folded
15 down together with the seat body 50 until into the position according to Fig. 15 forming a loading surface. As a result of this folding-down motion about the pivot spindle 79, the engagement of the detent hook 81 with the detent pin 82 of the floor-side beam 83 to the cabin frame 2 is also triggered automatically.

20 In order to enable a folding-down motion of the seat units 18 from their position according to Fig. 13 into the position according to Fig. 15, the headrests 57 of the seat units 18 are attached in the form of a mesh to an outer longitudinally running roof beam 6, 10 in a suspended manner and additionally are connected to the upper region of an associated backrest 56. Consequently, once their attachment has been released, they can be folded down onto the associated backrest 56 in a space-saving manner so
25 that they do not hinder the described folding motion of the seat units 18 so as to form a loading surface. In the folded-down position they are additionally suitable for covering the seat belts in a pocket-like manner. An illustration of them in the folded-down position forming a pocket has been avoided in order to simplify the illustration of the seat units 18 in the drawings.

30 The suspended attachment is provided for example by means of a pair of hooks 88 of the mesh-like headrests 57, which are suspended from wire loops 90 welded on to the roof beams 6, 10.

The automatic lowering is preferably embodied in two steps in that the inner tube 89 of the vertical beam 87 can be latched in an intermediate position. In a resultant possible preliminary stage of the lowering into the position according to Fig. 13, the backrest 56 has an access position advantageous for the pocket-like attachment of the folded-down headrest 57.

5

Claims

1. A useful cabin space of a motor vehicle for transporting personnel and materials, comprising a cabin frame intended for a removable cabin shell and formed by longitudinal beams and transverse beams, and comprising a cabin interior construction, which has two rows of seats running opposite one another in the direction of travel and laterally above a central vehicle floor, with seat bench panels and backrests, which are connected to one another via a first pivot axis, wherein the seat bench panels together with the backrests, forming a loading surface, can be pivoted inwardly about a second pivot axis so that the usable cabin space can be converted into a loading space also accessible from the side, characterised in that seat bodies each intended for a person are provided on the seat bench panels and are each associated with each backrest and each having seat belts and a headrest, and each backrest can be lowered towards the seat body by means of a lowering mechanism and is locked to side beams detachably anchored in the cabin frame.
2. The useful cabin space as per claim 1, wherein the headrest is formed as a mesh connected to the backrest and is detachably secured to the roof region of the cabin frame in a suspended manner.
3. The useful cabin space according to claims 1 and 2, wherein the lowering mechanism has rod profiles engaging with each other telescopically and each backrest has a floor-side cross beam in a T-shape relative to said rod profiles, the ends of said cross beams each having a detent hook, and in that anchor openings are provided in floor-side longitudinal beams of the cabin frame and are intended for the engagement of said detent hooks.
4. The useful cabin space according to claim 1, wherein the cabin frame has side beams detachably secured therein, on which side beams there is provided a securing tab for each backrest, and in that a bolt intended for the engagement in the securing tab is provided on the rear side of each backrest.
5. The useful cabin space according to claim 4, wherein the side beams have locking cams at their ends, which locking cams are detachably engaged in cam receptacles of detachable lateral vertical beams of a middle frame of the cabin frame.
6. The useful cabin space according to claim 5, wherein the side beams are connected to side loading flaps secured pivotably to the cabin frame and are mounted rotatably

about their longitudinal axis by means of their locking cams arranged at their ends for engagement in a cam receptacle.

5 7. The useful cabin space according to claim 6, wherein the locking cams are forked in a V-shape and can be rotated into engagement on a detent wedge of the cam receptacle.

8. The useful cabin space according to any one of claims 5 to 7, wherein a gearwheel sector having an eccentric set of teeth is secured to the side beams with the same axis, said gearwheel sector being engaged with a second gearwheel sector provided on a pivotable locking lever, wherein the locking lever can be latched.

9. The useful cabin space according to claim 5, wherein a hook-shaped engagement claw is provided at the upper end of the vertical beams and is hooked in an interlocked and frictionally engaged manner in an anchoring receptacle provided in the middle on the roof beam, and the lower end of the vertical beams is secured to floor-side longitudinal beams of the cabin frame by at least one screw connection.

10

1/5

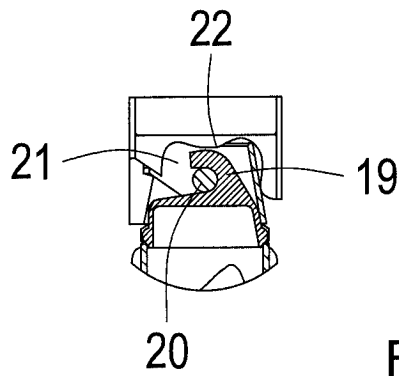
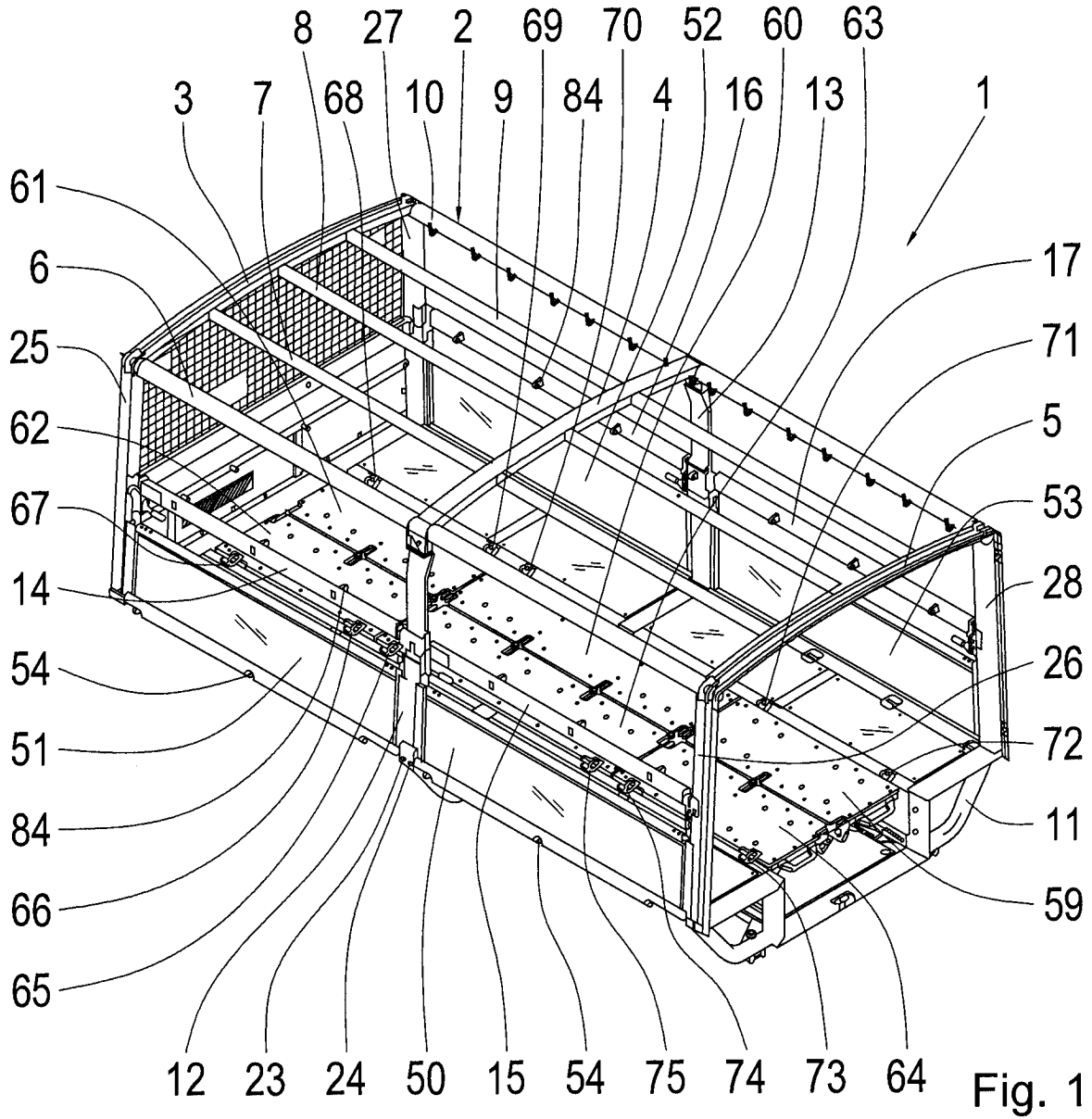

Fig. 2

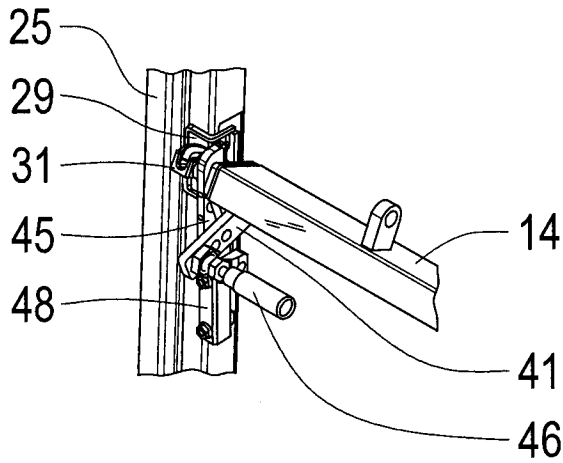

Fig. 3

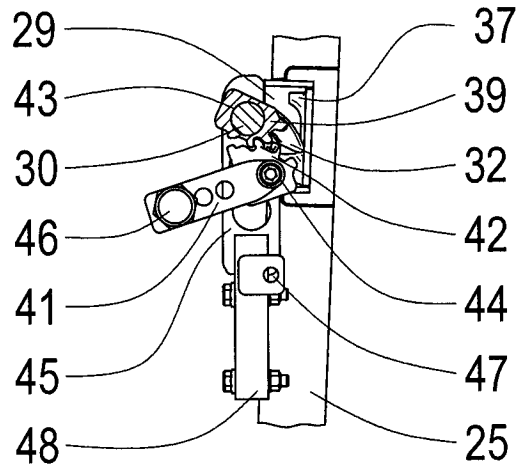

Fig. 4

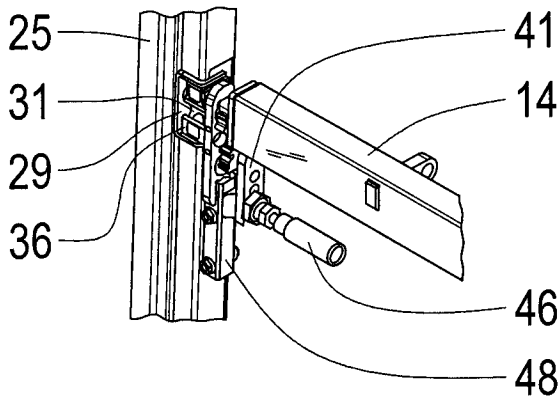

Fig. 5

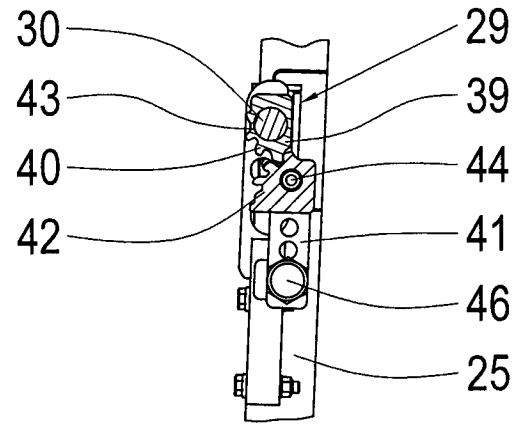

Fig. 6

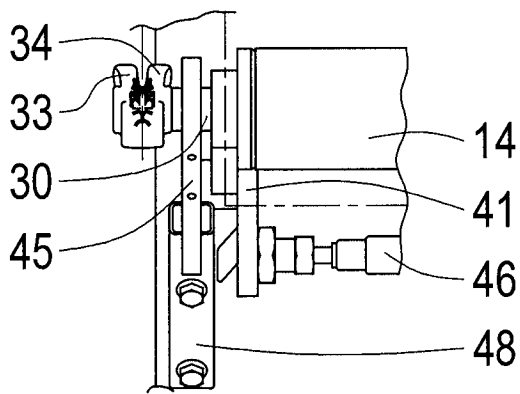

Fig. 7

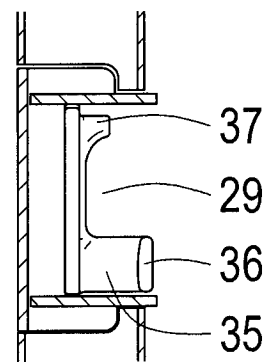

Fig. 8

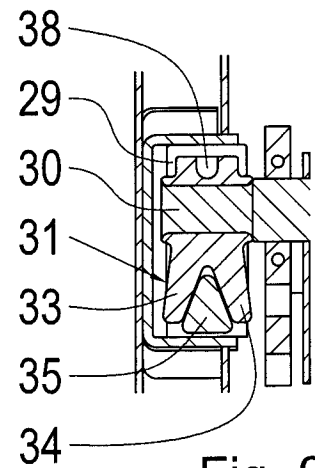

Fig. 9

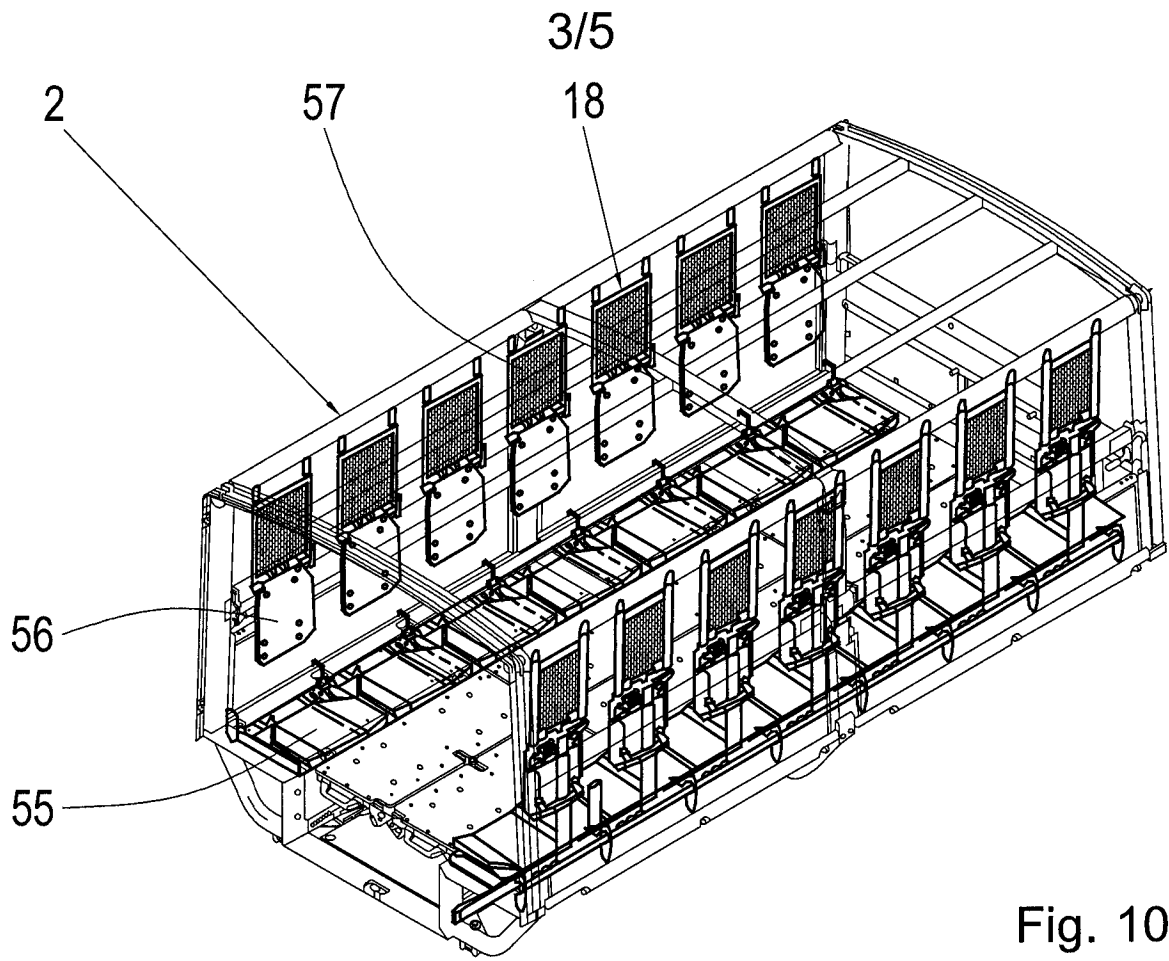

Fig. 10

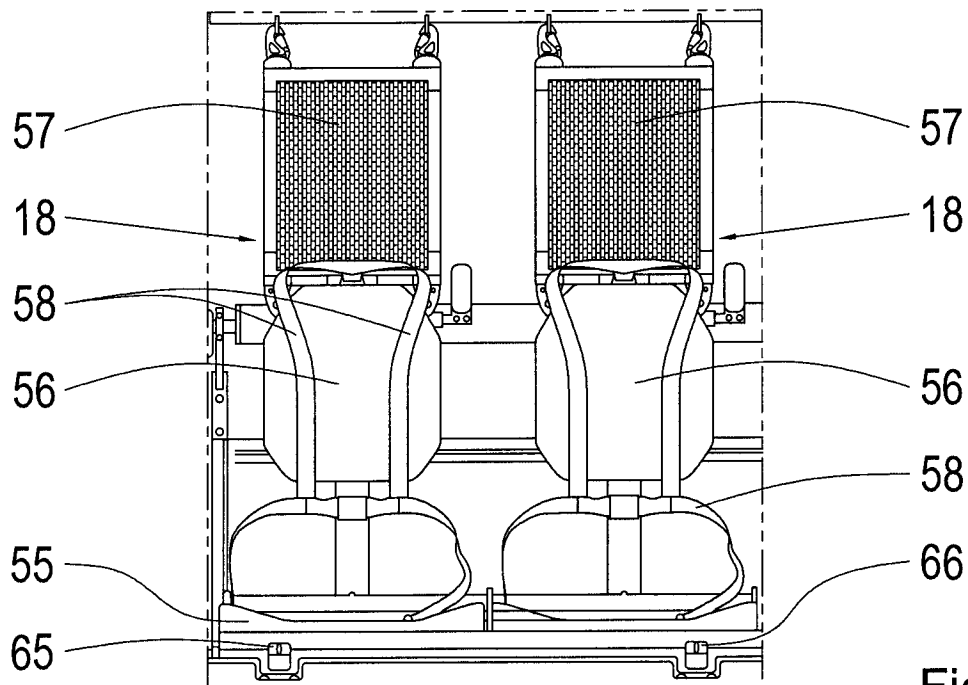

Fig. 11

4/5

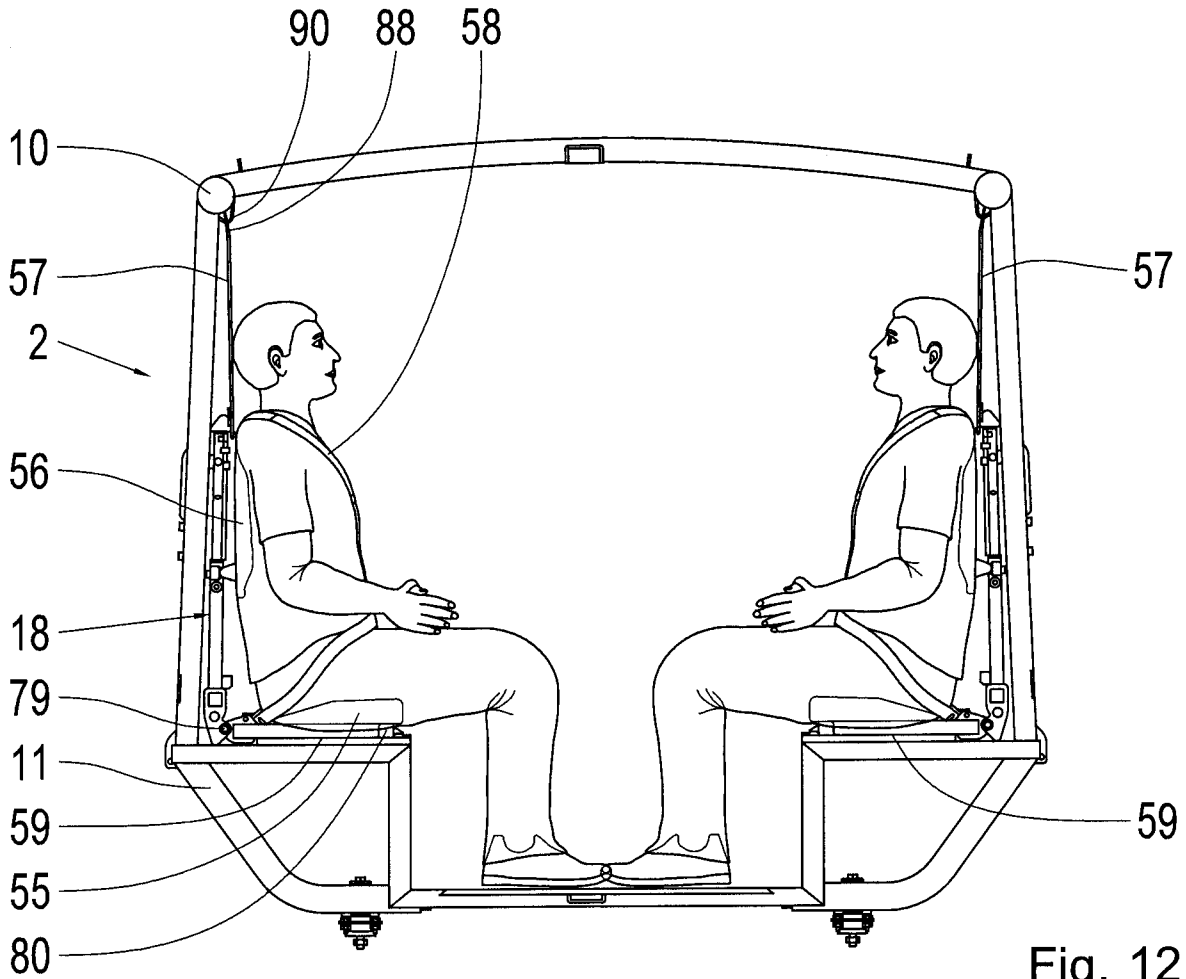

Fig. 12

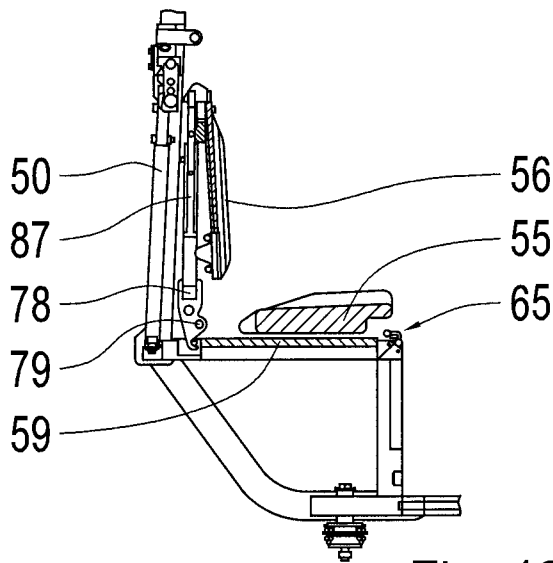

Fig. 13

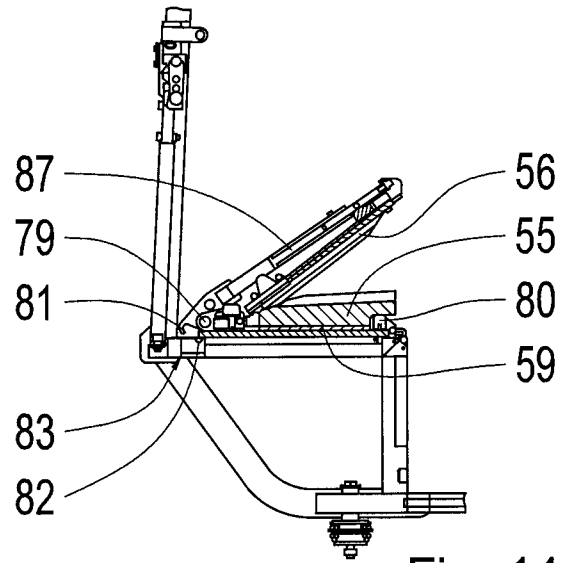

Fig. 14

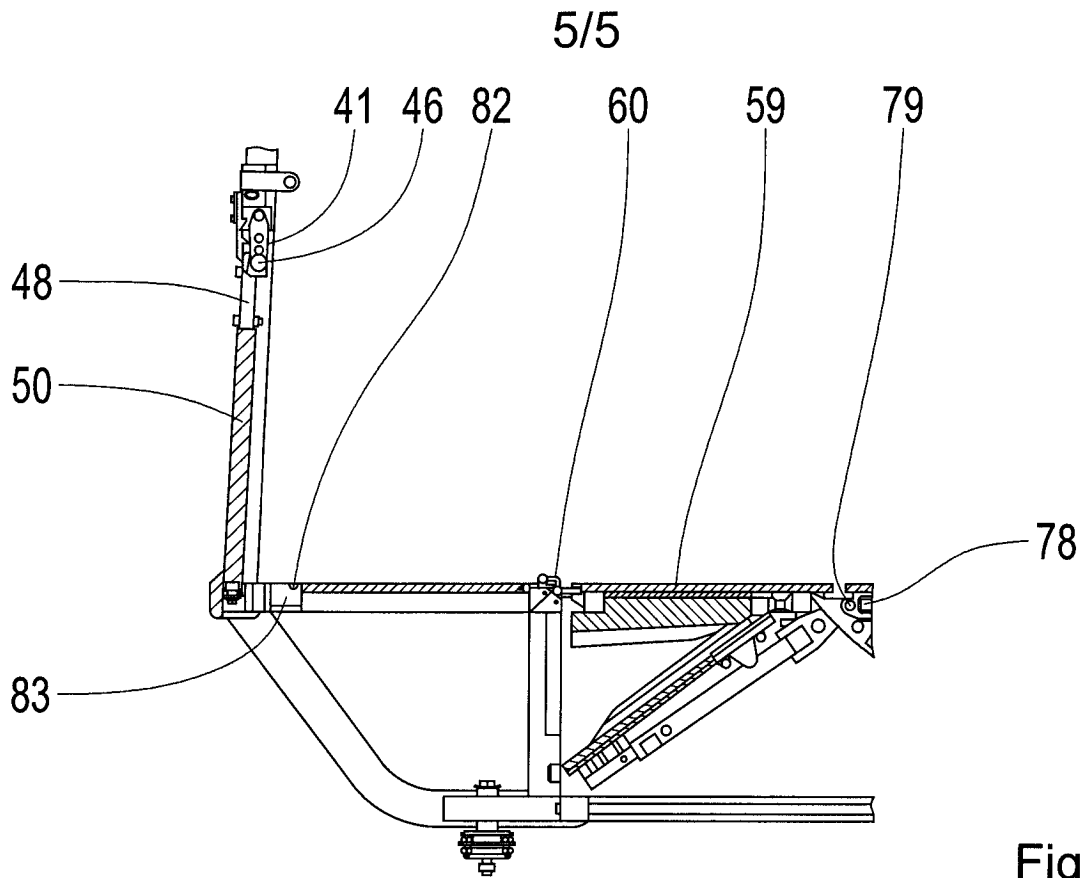

Fig. 15

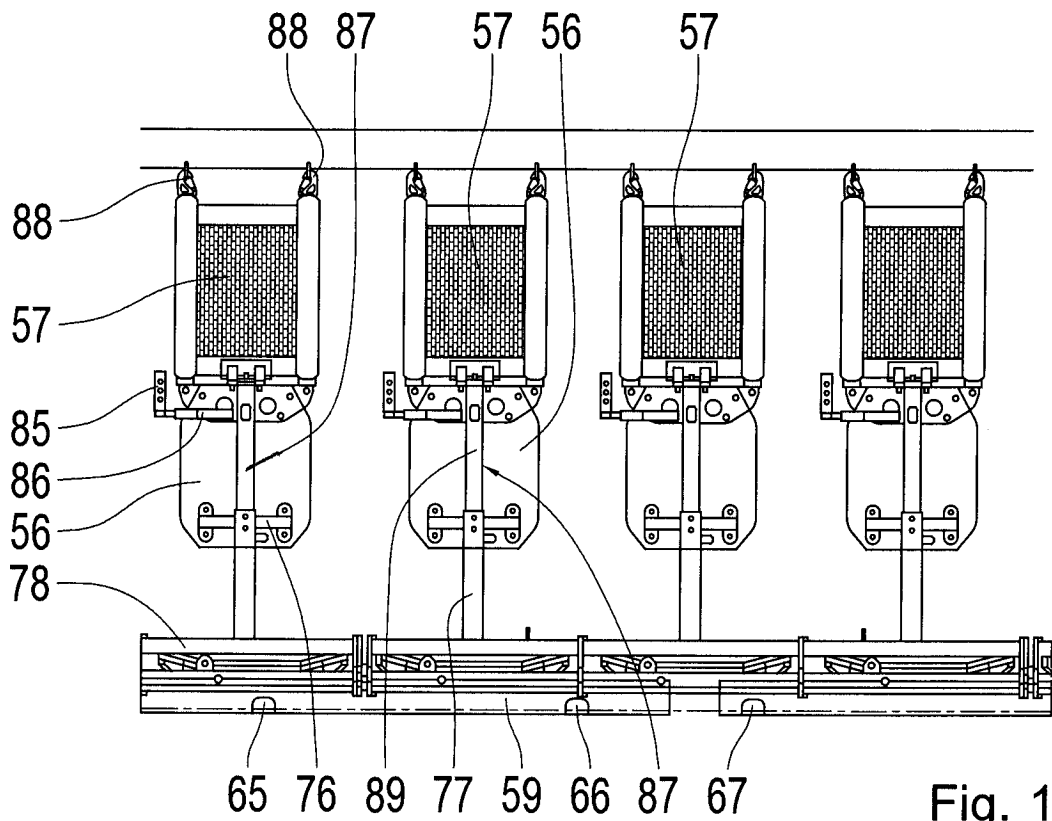

Fig. 16