



(51) International Patent Classification:

B43K 8/04 (2006.01) *B43K 8/03* (2006.01)
B43K 8/00 (2006.01) *B43K 23/12* (2006.01)
B43K 8/02 (2006.01)

(21) International Application Number:

PCT/US2017/028074

(22) International Filing Date:

18 April 2017 (18.04.2017)

(25) Filing Language:

English

(26) Publication Language:

English

(30) Priority Data:

62/325,512 21 April 2016 (21.04.2016) US

(71) Applicant: **MILWAUKEE ELECTRIC TOOL CORPORATION** [US/US]; 13135 West Lisbon Road, Brookfield, WI 53005 (US).

(72) Inventor: **BALLARD, James, G.**; 1107 Greenmeadow Drive, Waukesha, WI 53188 (US).

(74) Agent: **BUSH, Gayle, A.** et al.; Michael Best & Friedrich LLP, 100 East Wisconsin Avenue, Suite 3300, Milwaukee, WI 53202-4108 (US).

(81) Designated States (*unless otherwise indicated, for every kind of national protection available*): AE, AG, AL, AM, AO, AT, AU, AZ, BA, BB, BG, BH, BN, BR, BW, BY, BZ, CA, CH, CL, CN, CO, CR, CU, CZ, DE, DJ, DK, DM, DO, DZ, EC, EE, EG, ES, FI, GB, GD, GE, GH, GM, GT, HN, HR, HU, ID, IL, IN, IR, IS, JP, KE, KG, KH, KN, KP, KR, KW, KZ, LA, LC, LK, LR, LS, LU, LY, MA, MD, ME, MG, MK, MN, MW, MX, MY, MZ, NA, NG, NI, NO, NZ, OM, PA, PE, PG, PH, PL, PT, QA, RO, RS, RU, RW, SA, SC,

SD, SE, SG, SK, SL, SM, ST, SV, SY, TH, TJ, TM, TN, TR, TT, TZ, UA, UG, US, UZ, VC, VN, ZA, ZM, ZW.

(84) Designated States (*unless otherwise indicated, for every kind of regional protection available*): ARIPO (BW, GH, GM, KE, LR, LS, MW, MZ, NA, RW, SD, SL, ST, SZ, TZ, UG, ZM, ZW), Eurasian (AM, AZ, BY, KG, KZ, RU, TJ, TM), European (AL, AT, BE, BG, CH, CY, CZ, DE, DK, EE, ES, FI, FR, GB, GR, HR, HU, IE, IS, IT, LT, LU, LV, MC, MK, MT, NL, NO, PL, PT, RO, RS, SE, SI, SK, SM, TR), OAPI (BF, BJ, CF, CG, CI, CM, GA, GN, GQ, GW, KM, ML, MR, NE, SN, TD, TG).

Published:

— with international search report (Art. 21(3))

(54) Title: INTERNAL PRESSURE REGULATING MARKER PEN

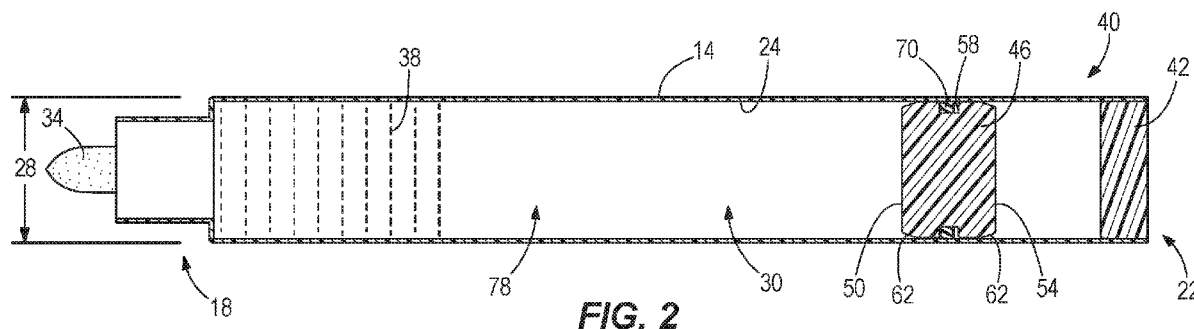

(57) Abstract: A writing implement is configured to dispense material onto a work surface. The writing implement includes a body having a first end, a second end, and an inner surface. The writing implement also includes a nib coupled to the first end. The nib is configured to allow the material to be dispensed onto the work piece. The writing implement further includes a pressure regulating assembly coupled to the body. The pressure regulating assembly and the inner surface define a cavity configured to hold the material. The pressure regulating assembly is moveable relative to the body in response to a pressure change within the cavity.

WO 2017/184570 A1

INTERNAL PRESSURE REGULATING MARKER PEN

CROSS-REFERENCE TO RELATED APPLICATIONS

[0001] This application claims priority to U.S. Provisional Patent Application No. 62/325,512, filed April 21, 2016, the content of which is incorporated herein by reference.

FIELD OF THE INVENTION

[0002] The present invention relates to marker pens, and more particularly to regulating an internal pressure within a marker pen.

BACKGROUND

[0003] A marker pen typically includes a body having a first end and a second end. The first end is coupled to a nib (e.g., tip) and the second end is an impermeable end cap that is fixed to the body. The body also defines a cavity having a fixed volume between the first end and the second end to hold a writing material (e.g., ink, paint, etc.). The nib is used to dispense the writing material from the cavity and onto a work surface.

SUMMARY

[0004] In one aspect, a writing implement is configured to dispense material onto a work surface. The writing implement includes a body having a first end, a second end, and an inner surface. The writing implement also includes a nib coupled to the first end. The nib is configured to allow the material to be dispensed onto the work piece. The writing implement further includes a pressure regulating assembly coupled to the body. The pressure regulating assembly and the inner surface define a cavity configured to hold the material. The pressure regulating assembly is moveable relative to the body in response to a pressure change within the cavity.

[0005] In another aspect, a writing implement is configured to dispense material onto a work surface. The writing implement includes a body having a first end, a second end, and an inner surface. The writing implement also includes a nib coupled to the first end. The nib is configured to allow the material to be dispensed onto the work piece. The writing implement further includes a pressure regulating assembly coupled to the body. The pressure regulating assembly and the inner surface define a cavity configured to hold the material at a

desired pressure. The pressure regulating assembly is moveable relative to the body to control an actual pressure within the cavity relative to the desired pressure.

[0006] In yet another aspect, a method of manufacturing a writing implement includes providing a body having a first end, a second end, and an inner surface. The method also includes inserting a piston through the second end of the body to define a cavity between the inner surface of the body and the piston. The piston is configured to be moveable relative to the body to control a pressure within the cavity. The method further includes injecting a material through the first end of the body into the cavity and coupling a nib to the first end of the body. The nib is configured to allow the material to be dispensed onto a work surface.

[0007] Other aspects of the invention will become apparent by consideration of the detailed description and accompanying drawings.

BRIEF DESCRIPTION OF THE DRAWINGS

[0008] FIG. 1 is a side view of a marker pen according to an embodiment of the invention.

[0009] FIG. 2 is a cross-sectional view of FIG. 1 taken along 2—2.

[0010] FIG. 3 is a side view of a piston internally coupled within the marker pen of FIG. 1.

[0011] FIG. 4 is a front view of a seal that is coupled to the piston of FIG. 3.

[0012] FIG. 5 is a cross-sectional view of FIG. 4 taken along 5—5.

[0013] FIG. 6 is a cross-sectional view of FIG. 1 taken along 2—2 illustrating a positive internal pressure change within the marker pen.

[0014] FIG. 7 is a cross-sectional view of FIG. 1 taken along 2—2 illustrating a negative internal pressure change within the marker pen.

[0015] FIG. 8 is a cross-sectional view of a marker pen according to another embodiment of the invention including a pressure regulating assembly in a first position.

[0016] FIG. 9 is a cross-sectional view of the marker pen of FIG. 8 including the pressure regulating assembly in a second position.

[0017] Before any embodiments of the invention are explained in detail, it is to be understood that the invention is not limited in its application to the details of construction and the arrangement of components set forth in the following description or illustrated in the following drawings. The invention is capable of other embodiments and of being practiced or of being carried out in various ways. Also, it is to be understood that the phraseology and terminology used herein is for the purpose of description and should not be regarded as limiting.

DETAILED DESCRIPTION

[0018] FIGS. 1 and 2 illustrate a marker pen 10 (e.g., a permanent marker, writing implement, etc.) including a body 14 having a first end 18 and a second end 22. A cap 26 is removably coupled to the first end 18 for covering and protecting the first end 18 of the marker 10. As shown in FIG. 2, the body 14 includes an inner surface 24 that defines an internal diameter 28. The inner surface 24 also defines an internal cavity 30 of the body 14. The cavity 30 is in fluid communication with a tip or nib 34 that is coupled to the first end 18. In addition, a portion of the cavity 30 contains a liquid writing material or solution 38 (e.g., ink, etc.) that is configured to flow through the nib 34 to be transferred to a work surface. In the illustrated embodiment, the liquid solution 38 is a permanent writing solution (e.g., paint solution and/or a metallic solution, etc.). In other embodiments, the liquid solution 38 may be a highlighter or fluorescent solution. In further embodiments, the liquid solution 38 may be a removable or washable solution (e.g., non-permanent).

[0019] With reference to FIGS. 2-4, a pressure regulating assembly 40 includes a plug or end cap 42 that is coupled to the second end 22 of the marker 10 and a piston 46 slidably received within the cavity 30 between the plug 42 and the liquid solution 38. The illustrated piston 46 defines a solid cylindrical member including a first surface 50 that faces the liquid solution 38, a second surface 54 that faces the plug 42, a groove 58 positioned between the surfaces 50, 54, and a chamfer 62 located between the groove 58 and the first surface 50 as well as between the groove 58 and the second surface 54 (FIG. 3). In other embodiments, the piston 46 can be a hollow cylindrical member. In the illustrated embodiment, the piston 46 includes an outer diameter 66 (FIG. 3), which is sized and configured relative to the inner

diameter 28 of the body 14 so that the piston 46 is slidable relative to the body 14. The illustrated chamfers 62 also allow for smooth slidable movement of the piston 46 within the cavity 30. In the illustrated embodiment, the tolerance between the diameters 28, 66 is about plus or minus 0.05 millimeters. In addition, the groove 58 receives a seal 70 that directly contacts the inner surface 24 of the body 14. In one embodiment, the seal 70 and the piston 46 directly contact the inner surface 24. As shown in FIG. 5, the seal 70 includes four arcuate or concave sides 74 (e.g., a quad-ring or X-ring). In other embodiments, the seal 70 may include a circular cross section (e.g., an O-ring), an ellipse cross section, a square cross section, a rectangular cross section, etc.

[0020] With reference back to FIG. 2, the illustrated plug 42 is configured to provide communication between the cavity 30 and the ambient air surrounding the marker 10 and to inhibit dust and debris from entering the cavity 30. In particular, the plug 42 allows air to pass therethrough to either exit or enter the cavity 30 (e.g., between the second surface 54 and the plug 42). In other embodiments, the plug 42 may be an absorbent or porous cylindrical member.

[0021] To assemble or manufacture the marker 10, the seal 70 is coupled to the piston within the groove 58 so that the piston 46 and the seal 70 are both inserted into the body 14 through the second end 22. In particular, the piston 46 and the seal 70 are positioned within the cavity 30 at a desired location relative to the second end 22 to define a desired volume of the cavity 30 between the first surface 50 of the piston 46 and the first end 18 (FIG. 2). While the body 14 is oriented in an upright position (e.g., the first end 18 is above the second end 22), the liquid solution 38 is injected through the first end 18 and into the cavity 30 (e.g., into the volume defined between the first surface 50 and the first end 18). In one embodiment, the piston 46 may be temporally fixed relative to the body 14 while the cavity 30 is filled with the liquid solution 38. Once a determined amount of the liquid solution 38 is injected into the cavity 30, the nib 34 is coupled to the first end 18. In addition, the plug 42 is coupled to the second end 22. In the illustrated embodiment, the piston 46 and seal 70 are sized and configured to inhibit the liquid solution 38 from traveling between the piston 46 and the plug 42. In other words, only ambient air is located between the piston 46 and the plug 42.

[0022] In the illustrated embodiment, the piston 46 is inserted into the body 14 at the desired location so that a desired internal pressure 78 (e.g., ambient pressure surrounding the

marker 10) within the cavity 30 is created once the liquid solution 38 is injected into the cavity 30 and the nib 34 is coupled to the first end 18. The desired internal pressure 78 is substantially maintained by the frictional engagement between the piston 46 and/or the seal 70 against the inner surface 24 of the body 14. In other embodiments, the desired internal pressure 78 may be slightly greater than the ambient pressure surrounding the marker 10.

[0023] In operation, the nib 34 is depressed against the work surface to allow the liquid solution 38 to travel from the cavity 30 through the nib 34 to be dispensed onto the work piece (e.g., fluid communication between the cavity 30 and the ambient environment is provided by depressing the nib 34 onto the work surface). Once the nib 34 is moved out of contact with the work surface, the nib 34 blocks the liquid solution 38 from traveling from the cavity 30 through the nib 34 and onto the work surface (e.g., fluid communication between the cavity 30 and the ambient environment is blocked by the nib 34).

[0024] However, the pressure within the cavity 30 may increase or decrease upon either expansion or contraction of the liquid solution 38. For example, if the temperature of the liquid solution 38 increases (e.g., the marker 10 is in direct sunlight), an actual pressure 80 (FIG. 6) within the cavity 30 will also increase above the desired internal pressure 78 (e.g., a positive pressure change). If the higher actual pressure 80 is maintained within the marker 10, more liquid solution 38 than is desired will initially exit the nib 34 once the nib 34 is depressed onto the work surface (e.g., the higher actual pressure 80 will push out an undesirable amount of liquid solution 38 onto the work surface). To avoid this situation, the illustrated pressure regulating assembly 40 regulates (e.g., controls) the actual pressure 80 within the cavity 30 relative to the desired internal pressure 78 before the nib 34 is depressed onto the work surface. In particular, the higher actual pressure 80 within the cavity 30 will act against the first surface 50 of the piston 46 to move the piston 46 towards the plug 42, thereby increasing a volume of the cavity 30 between the nib 34 and the first surface 50. As a result, the actual pressure 80 within the cavity 30 decreases to be substantially equal with the desired internal pressure 78. As the piston 46 moves towards the plug 42, the piston 46 pushes the ambient air positioned between the second surface 54 and the plug 42 through the plug 42 and into the ambient environment. By substantially maintaining the desired pressure 78 within the cavity 30, a constant and desired flow of liquid solution 38 travels through the nib 34 once the nib 34 is depressed onto the work surface regardless of the orientation of the marker 10 (e.g., using the marker 10 upside down).

[0025] With reference to FIG. 7, if the temperature of the liquid solution 38 decreases, the actual pressure 80 within the cavity 30 will also decrease below the determined internal pressure 78 (e.g., a negative pressure change). As such, the lower actual pressure 80 within the cavity 30 will move the piston 46 towards the first end 18 to again substantially equalize the actual pressure 80 with the desired internal pressure 78.

[0026] FIGS. 8 and 9 illustrate a portion of a marker 210 according to another embodiment of the invention. The marker 210 is similar to the marker 10 with similar components including similar reference numbers incremented by 200. Only the differences between the markers 10, 210 will be described below in detail. In addition, components or features described with respect to only one or some of the embodiments described herein are equally applicable to any other embodiments described herein.

[0027] The illustrated marker 210 includes a pressure regulating assembly 240 coupled to a second end 222 of a body 214 and is in communication with a cavity 230 defined by the body 214. The pressure regulating assembly 240 includes a body 242 having an inlet 286 and an outlet 290 with a valve 294 (e.g., a ball valve, etc.) and a biasing member 298 (e.g., a coil spring, etc.) located between the inlet and outlet 286, 290. In particular, the valve 294 is positioned between a first edge 300 of the inlet 286 and a tapered surface or second edge 302 defined on an inner surface of the body 242. The tapered surface 302 is positioned between the edge 300 and the outlet 290. The biasing member 298 provides a biasing force against the valve 294 towards the inlet 286 thereby creating a biasing pressure 306 of the valve 294 acting on the first edge 300. The illustrated biasing pressure 306 is a determined pressure. In the illustrated embodiment, the combination of the valve 294 and the biasing member 298 is commonly referenced as a check valve. In other embodiments, the valve 294 and/or the biasing member 298 may be positioned between the inlet 286 and the cavity 230.

[0028] In operation, the biasing member 298 forces the valve 294 into engagement with the first edge 300 when an actual internal pressure 280 within the cavity 230 is less than the biasing pressure 306 (FIG. 8). As such, communication between the cavity 230 and the outlet 290 is blocked by the valve 294 engaging the first edge 300 of the body 242.

[0029] With reference to FIG. 9, when the actual internal pressure 280 of the cavity 230 is greater than the biasing pressure 306 (e.g., the actual internal pressure 280 exceeds a predetermined limit), the internal pressure 280 acts on the valve 294 to move the valve 294

towards the outlet 290. As such, the internal pressure 280 is allowed to flow around the valve 294 and exit the marker 210 through the outlet 290. In one embodiment, the internal pressure 280 can push the valve 294 into engagement with the tapered surface 302. In this situation, the internal pressure 280 within the cavity 230 is still allowed to escape through the outlet 290 (e.g., engagement between the valve 294 and the tapered surface 302 does not block communication between the cavity 230 and the outlet 290). The internal pressure 280 will continue to exit the outlet 290 (e.g., the internal pressure 280 within the cavity 230 will decrease) until the internal pressure 280 substantially equalizes with a desired internal pressure 278 of the cavity 230. Thereafter, the biasing member 298 pushes the valve 294 back into engagement with the first edge 300 to block fluid communication between the cavity 230 and the outlet 290.

[0030] In further embodiments, the pressure regulating assembly 240 can include a filter positioned between the cavity 230 and the inlet 286 to inhibit a liquid solution from traveling past the inlet 286 but allows air to travel past the inlet 286 and toward the outlet 290.

[0031] Although the invention has been described in detail with reference to certain preferred embodiments, variations and modifications exist within the scope and spirit of one or more independent aspects of the invention as described.

[0032] Various features and advantages of the invention are set forth in the following claims.

CLAIMS

1. A writing implement configured to dispense material onto a work surface, the writing implement comprising:
 - a body including a first end, a second end, and an inner surface;
 - a nib coupled to the first end, the nib configured to allow the material to be dispensed onto the work piece; and
 - a pressure regulating assembly coupled to the body, the pressure regulating assembly and the inner surface defining a cavity configured to hold the material, the pressure regulating assembly moveable relative to the body in response to a pressure change within the cavity.
2. The writing implement of claim 1, wherein the pressure regulating assembly is coupled within the body, and wherein the pressure regulating assembly includes a piston having a first surface that faces the first end and a second surface that faces the second end, and wherein the cavity is configured to hold the material between the first surface and the nib.
3. The writing implement of claim 2, wherein a volume of the cavity increases as the piston moves toward the second end in response to the pressure within the cavity increasing above a desired pressure within the cavity.
4. The writing implement of claim 3, wherein the volume of the cavity decreases as the piston moves toward the first end in response to the pressure within the cavity decreasing below the desired pressure within the cavity.
5. The writing implement of claim 2, wherein the piston includes a groove positioned between the first surface and the second surface, and wherein the groove is sized to receive a seal, and wherein at least one of the piston and the seal slidably engages the inner surface of the body.
6. The writing implement of claim 2, wherein the pressure regulating assembly includes a porous end cap coupled to the second end so that the piston is coupled between the porous end cap and the nib, and wherein the porous end cap is configured to allow ambient air to pass through the porous end cap.

7. The writing implement of claim 1, wherein the pressure regulating assembly includes a check valve coupled to the second end of the body.

8. The writing implement of claim 7, wherein the check valve includes a check valve body having an inlet, an outlet, a valve, and a biasing member, and wherein the valve and the biasing member are positioned between the inlet and the outlet, and wherein the biasing member is configured to bias the valve into engagement with a first edge of the inlet to block the pressure within the cavity from exiting the outlet.

9. The writing implement of claim 8, wherein the valve is moveable toward the outlet to allow the pressure within the cavity to exit the outlet in response to the pressure within the cavity increasing above a desired pressure within the cavity.

10. A writing implement configured to dispense material onto a work surface, the writing implement comprising:

a body including a first end, a second end, and an inner surface;

a nib coupled to the first end, the nib configured to allow the material to be dispensed onto the work piece; and

a pressure regulating assembly coupled to the body, the pressure regulating assembly and the inner surface defining a cavity configured to hold the material at a desired pressure, the pressure regulating assembly moveable relative to the body to control an actual pressure within the cavity relative to the desired pressure.

11. The writing implement of claim 10, wherein the pressure regulating assembly is coupled within the body, and wherein the pressure regulating assembly includes a piston having a first surface that faces the first end and a second surface that faces the second end, and wherein the cavity is configured to hold the material between the first surface and the nib.

12. The writing implement of claim 11, wherein a volume of the cavity increases as the piston moves toward the second end in response to the actual pressure within the cavity increasing above the desired pressure within the cavity.

13. The writing implement of claim 12, wherein the volume of the cavity decreases as the piston moves toward the first end in response to the actual pressure within the cavity decreasing below the desired pressure within the cavity.

14. The writing implement of claim 11, wherein the piston includes a groove positioned between the first surface and the second surface, and wherein the groove is sized to receive a seal, and wherein at least one of the piston and the seal slidably engages the inner surface of the body.

15. The writing implement of claim 11, wherein the pressure regulating assembly includes a porous end cap coupled to the second end so that the piston is coupled between the porous end cap and the nib, and wherein the porous end cap is configured to allow ambient air to pass through the porous end cap.

16. The writing implement of claim 10, wherein the pressure regulating assembly includes a check valve coupled to the second end of the body.

17. The writing implement of claim 16, wherein the check valve includes a check valve body having an inlet, an outlet, a valve, and a biasing member, and wherein the valve and the biasing member are positioned between the inlet and the outlet, and wherein the biasing member is configured to bias the valve into engagement with a first edge of the inlet to block the actual pressure within the cavity from exiting the outlet.

18. The writing implement of claim 17, wherein the valve is moveable toward the outlet to allow the actual pressure within the cavity to exit the outlet in response to the actual pressure within the cavity increasing above the desired pressure within the cavity.

19. A method of manufacturing a writing implement, the method comprising:
providing a body including a first end, a second end, and an inner surface;
inserting a piston through the second end of the body to define a cavity between the inner surface of the body and the piston, the piston configured to be moveable relative to the body to control a pressure within the cavity;
injecting a material through the first end of the body into the cavity; and
coupling a nib to the first end of the body, the nib configured to allow the material to be dispensed onto a work surface.

20. The method of claim 19, further comprising coupling a porous end cap to the second end of the body so that the piston is positioned between the porous end cap and the nib, wherein the porous end cap is configured to allow ambient air to pass through the porous end cap.

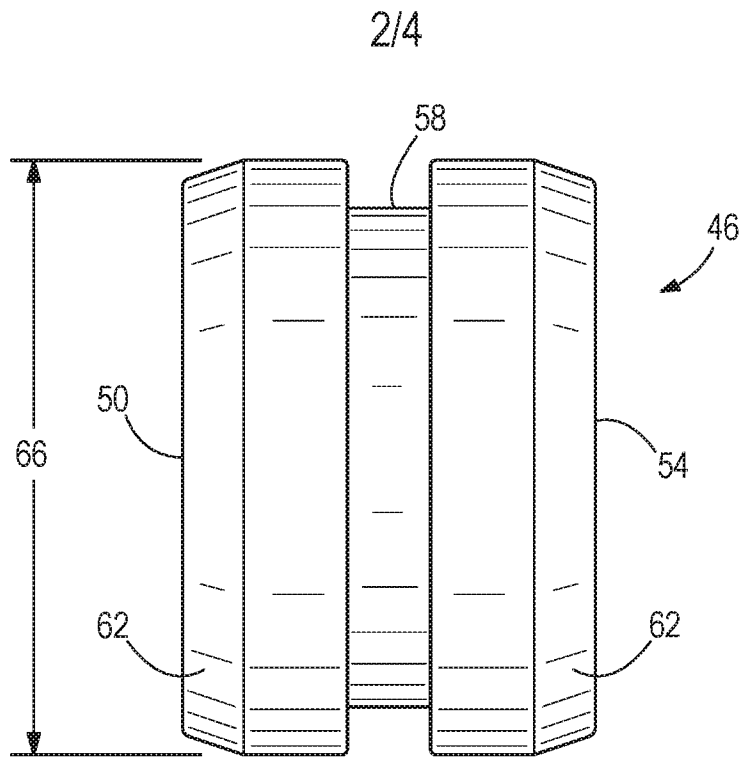

FIG. 3

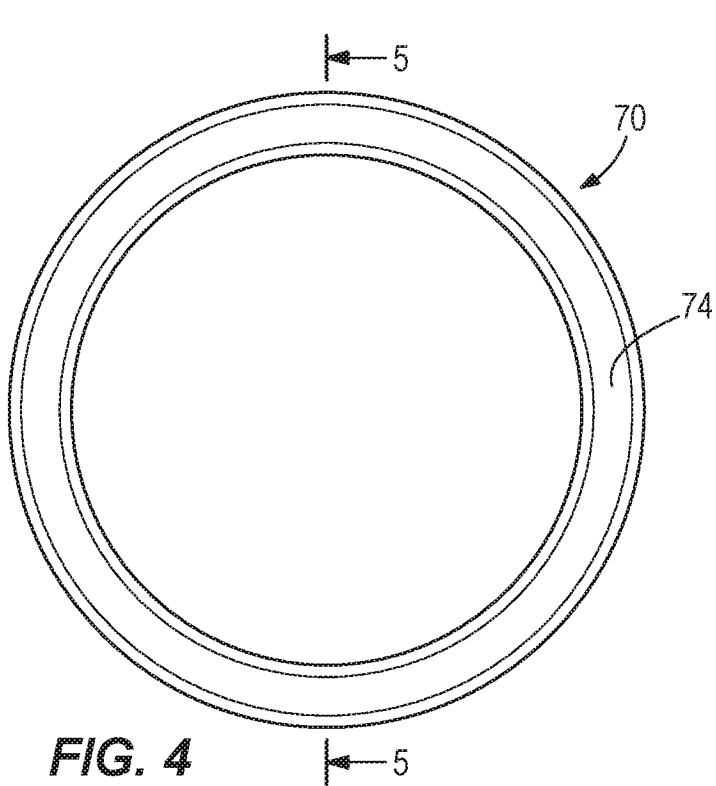

FIG. 4

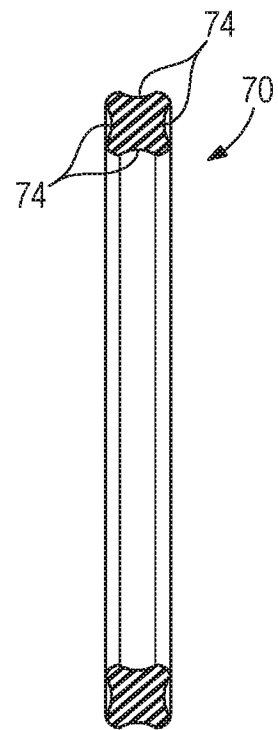

FIG. 5

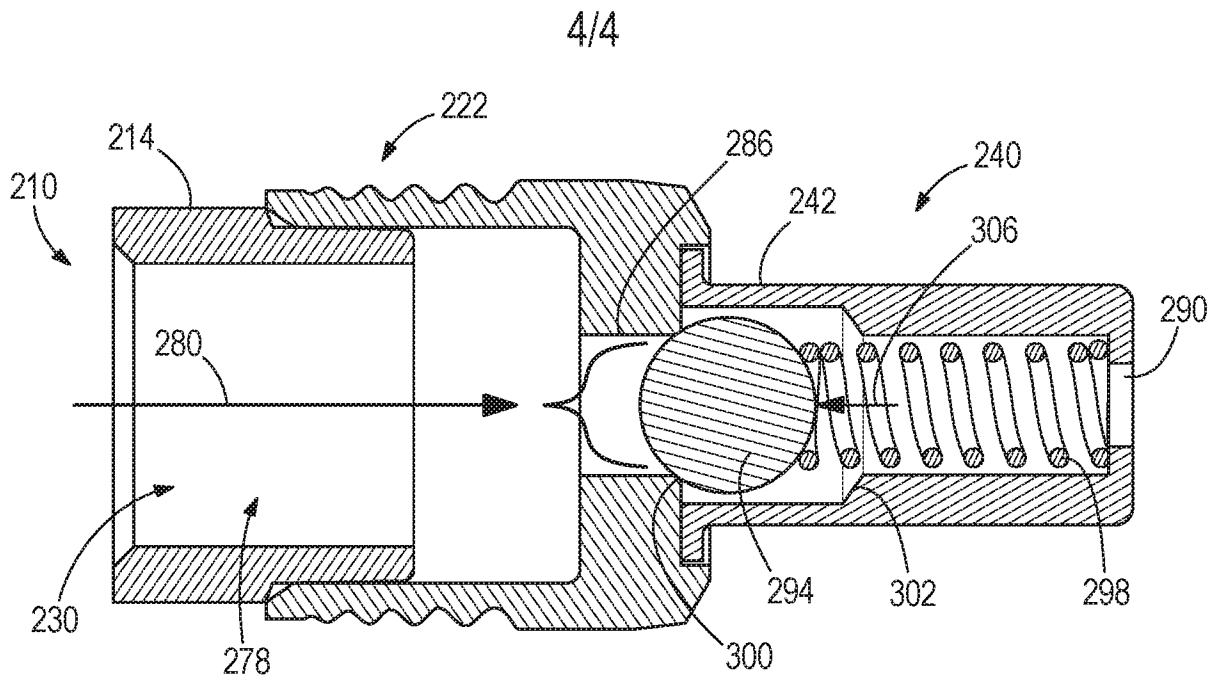

FIG. 8

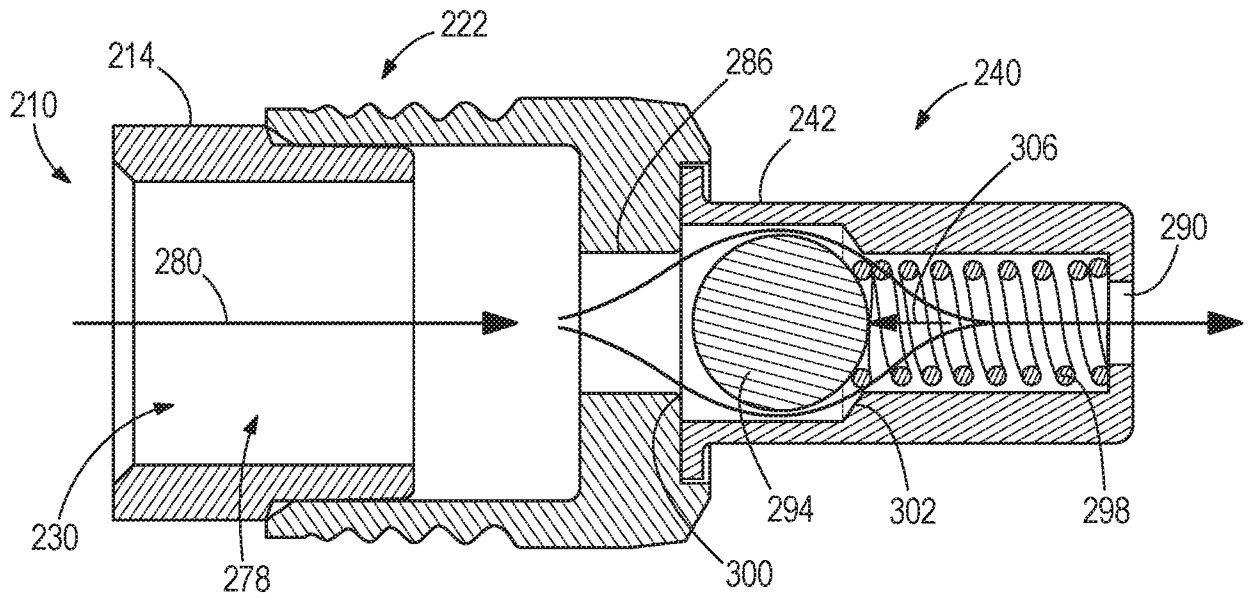

FIG. 9

A. CLASSIFICATION OF SUBJECT MATTER**B43K 8/04(2006.01)i, B43K 8/00(2006.01)i, B43K 8/02(2006.01)i, B43K 8/03(2006.01)i, B43K 23/12(2006.01)i**

According to International Patent Classification (IPC) or to both national classification and IPC

B. FIELDS SEARCHEDMinimum documentation searched (classification system followed by classification symbols)
B43K 8/04; B43K 5/06; B43K 5/02; B43M 11/06; B43K 8/00; B43K 8/02; B43K 8/03; B43K 23/12Documentation searched other than minimum documentation to the extent that such documents are included in the fields searched
Korean utility models and applications for utility models
Japanese utility models and applications for utility modelsElectronic data base consulted during the international search (name of data base and, where practicable, search terms used)
eKOMPASS(KIPO internal) & Keywords: writing implement, pressure, regulation, piston**C. DOCUMENTS CONSIDERED TO BE RELEVANT**

Category*	Citation of document, with indication, where appropriate, of the relevant passages	Relevant to claim No.
X	US 6102601 A (CHO-KAI HU) 15 August 2000 See column 1, lines 29-32, column 2, lines 15-46, column 3, lines 14-20, claims 1-9 and figures 1-4.	1-20
A	US 2003-0068191 A1 (JIRO HORI) 10 April 2003 See paragraphs [0056]-[0058] and figure 2.	1-20
A	US 5249875 A (JIRO HORI et al.) 05 October 1993 See claims 1-3 and figures 1-2,7-10.	1-20
A	US 6361234 B1 (RONALD S RUKAN et al.) 26 March 2002 See claims 1-8 and figures 1-2.	1-20
A	US 7938592 B2 (HISAMI TAMANO) 10 May 2011 See claim 1 and figure 8.	1-20

 Further documents are listed in the continuation of Box C. See patent family annex.

* Special categories of cited documents:

"A" document defining the general state of the art which is not considered to be of particular relevance

"E" earlier application or patent but published on or after the international filing date

"L" document which may throw doubts on priority claim(s) or which is cited to establish the publication date of another citation or other special reason (as specified)

"O" document referring to an oral disclosure, use, exhibition or other means

"P" document published prior to the international filing date but later than the priority date claimed

"T" later document published after the international filing date or priority date and not in conflict with the application but cited to understand the principle or theory underlying the invention

"X" document of particular relevance; the claimed invention cannot be considered novel or cannot be considered to involve an inventive step when the document is taken alone

"Y" document of particular relevance; the claimed invention cannot be considered to involve an inventive step when the document is combined with one or more other such documents, such combination being obvious to a person skilled in the art

"&" document member of the same patent family

Date of the actual completion of the international search

27 July 2017 (27.07.2017)

Date of mailing of the international search report

27 July 2017 (27.07.2017)

Name and mailing address of the ISA/KR

International Application Division
Korean Intellectual Property Office
189 Cheongsa-ro, Seo-gu, Daejeon, 35208, Republic of Korea

Facsimile No. +82-42-481-8578

Authorized officer

JANG, Gijeong

Telephone No. +82-42-481-8364



INTERNATIONAL SEARCH REPORT

Information on patent family members

International application No.

PCT/US2017/028074

Patent document cited in search report	Publication date	Patent family member(s)	Publication date
US 06102601 A	15/08/2000	None	
US 2003-0068191 A1	10/04/2003	AU 4028001 A AU 4457001 A BR 0101892 A CA 2346272 A1 CN 1181982 C CN 1427777 A EP 1281539 A1 EP 1281539 B1 ES 2203279 A1 ES 2203279 B1 ID 30107 A JP 03436728 B2 JP 2001-315483 A KR 10-2001-0103641 A TW I232182 B US 6607325 B2 WO 01-85471 A1	15/11/2001 20/11/2001 18/12/2001 08/11/2001 29/12/2004 02/07/2003 05/02/2003 03/12/2008 01/04/2004 16/06/2005 08/11/2001 18/08/2003 13/11/2001 23/11/2001 11/05/2005 19/08/2003 15/11/2001
US 5249875 A	05/10/1993	DE 69125774 T2 EP 0476492 A1 EP 0476492 B1	31/07/1997 25/03/1992 23/04/1997
US 6361234 B1	26/03/2002	AU 4198501 A BR 0109111 A CA 2402333 A1 CA 2402333 C CN 1225369 C CN 1427681 A EP 1261261 A1 EP 1261261 B1 JP 04131794 B2 JP 2003-525775 A MX PA02008713 A TW 548202 B WO 01-65970 A1	17/09/2001 03/06/2003 13/09/2001 13/11/2007 02/11/2005 02/07/2003 04/12/2002 23/12/2009 13/08/2008 02/09/2003 22/04/2003 21/08/2003 13/09/2001
US 7938592 B2	10/05/2011	CN 101511604 A CN 101511604 B EP 2062744 A1 EP 2062744 B1 JP 04137963 B2 JP 2008-062566 A KR 10-1130901 B1 KR 10-2009-0051073 A TW 200819311 A TW I417198 B US 2010-0172689 A1	19/08/2009 30/05/2012 27/05/2009 16/04/2014 20/08/2008 21/03/2008 28/03/2012 20/05/2009 01/05/2008 01/12/2013 08/07/2010

INTERNATIONAL SEARCH REPORT

Information on patent family members

International application No.

PCT/US2017/028074

Patent document cited in search report	Publication date	Patent family member(s)	Publication date
		WO 2008-029747 A1	13/03/2008