

J. N. Adams.

Making Tin Tubing.

N^o 102,466.

Patented May 3, 1870.

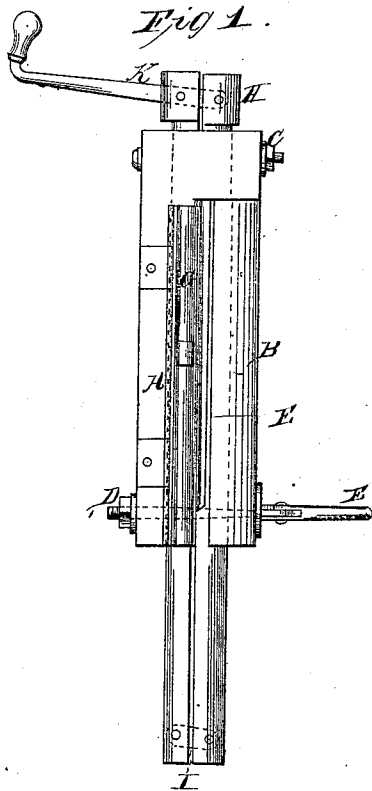
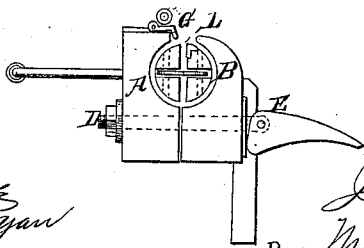

Fig 2.



Witnesses.

*M. Volcainde
Wm. D. Morgan*

Inventor.

J. N. Adams.
PER *Wm. D. Morgan*
Attorneys.

United States Patent Office.

JAMES N. ADAMS, OF CHILLICOTHE, MISSOURI.

Letters Patent No. 102,466, dated May 3, 1870.

IMPROVEMENT IN TIN-TUBING MACHINE.

The Schedule referred to in these Letters Patent and making part of the same.

To all whom it may concern:

Be it known that I, JAMES N. ADAMS, of Chillicothe, in the county of Livingston and State of Missouri, have invented a new and improved Tin-Tubing Machine; and I do hereby declare that the following is a full, clear, and exact description thereof, which will enable others skilled in the art to make and use the same, reference being had to the accompanying drawings forming part of this specification.

This invention relates to an improved machine for bending sheets of tin into tubing, lapping the edges and the ends of the section, and holding them for soldering; and

It consists of a sectional tubular shell, capable of being expanded or contracted, and having a slot along one side for the admission of the tin to the interior, wherein is a mandrel or former, divided longitudinally, for the purpose of expanding and contracting the same in a manner hereinafter explained.

Secured on one part of this mandrel or former is a copper strip. Under this strip the edge of the tin is inserted, to hold it in place while the said mandrel is turned, and winds the tin around it into the shell, after which the lapped edges are held opposite the slot in the shell for soldering, and pressed together by a hinged presser attached to the shell and projecting through the slot.

The section thus formed is then shoved along the mandrel, so that the next sheet of tin bent up will be lapped on the end of it, all as hereinafter more fully specified.

Figure 1 is a side elevation of my improved tubing-machine.

Figure 2 is an end elevation of the same.

Similar letters of reference indicate corresponding parts.

The shell is composed of two parts, A B, of wood or other suitable material, with semicircular grooves in the faces, which are clamped closely together at one end by a bolt and nut, C, and at the other end by a bolt, D, and eccentric lever, E, so that they may be forced snugly together or slightly separated.

F is a slot separating that end of the shell A B, the bolt C passing transversely through it.

G is a long presser-plate, hinged to the top of the part A, and bent downward so as to project through a wide slot opening from the top into the hollow space formed by the semicircular grooves.

H is a mandrel or former, made in two semicircular parts, connected together at one end by a link, I, jointed at both ends, and similarly at the other end by a crank-lever, K, so that the two parts may be moved lengthwise on each other to separate them slightly or bring them together.

This mandrel or former is made to fit the hole through the shell loosely, and project at both ends, one having a head to which the crank is fitted, and the other is prolonged as much, or nearly as much, as the width of the tin to be formed.

One edge of the sheet of tin to be bent is passed through the slot in the shell, and under the copper strip L on the former.

The former or mandrel is then turned, after forcing the two parts of the shell together by the eccentric lever E, by which the sheet is drawn in and bent into tubular form, the edges lapping each other and brought opposite the slot and soldered; and, if necessary, the presser G is forced down upon the upper edge, to hold it firmly down upon the other to solder.

To discharge the tube so formed, the lever K is moved to contract the mandrel, and the eccentric lever is moved to open that end of the shell, which result is secured by the bolt C drawing together the two parts of the shell A B at the slot F.

This permits the tube to be shoved out on the end of the mandrel projecting from the shell; but it is not shoved so far but that the next sheet of tin put in to be bent up will, in the act of bending, be lapped on the tube sufficient to be joined thereto by soldering.

Each successive section, together with that previously attached, is shoved along the mandrel. In this way the projecting tube is suitably supported until the required length is produced.

Having thus described my invention,

I claim as new and desire to secure by Letters Patent—

1. The combination of the shell and mandrel or former, constructed, arranged, and operating substantially as specified.

2. The combination, with the shell and mandrel, of the presser G, substantially as specified.

J. N. ADAMS.

Witnesses:

JOHN COOMBS,
F. K. FLETCHER.