

HOLLOWAY & HUEY.

Hair Renovator.

No. 109,903.

Patented Dec. 6, 1870.

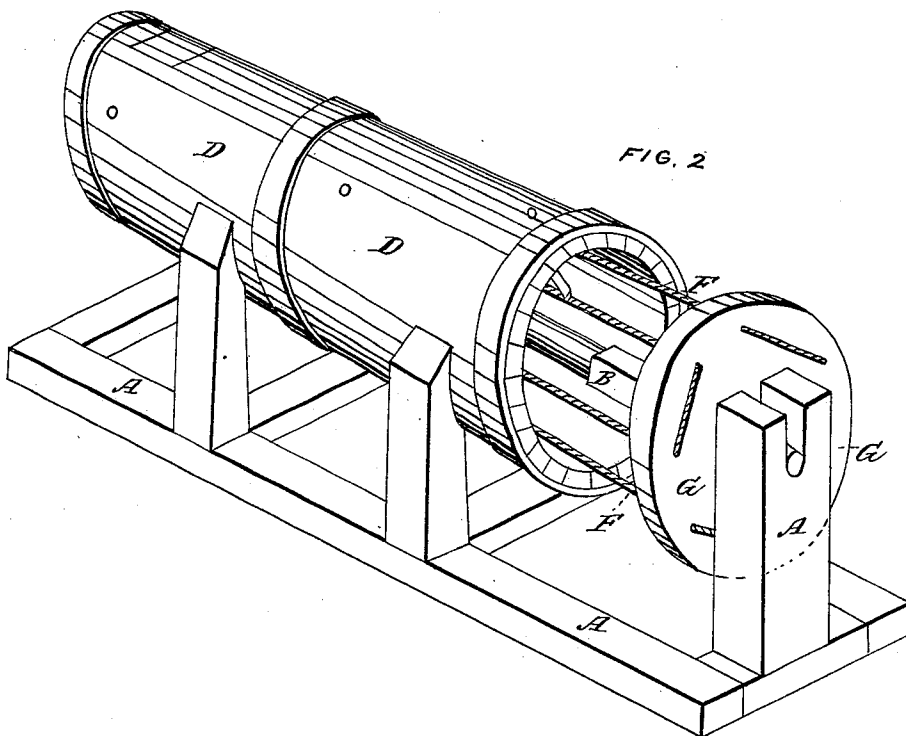

FIG. 2

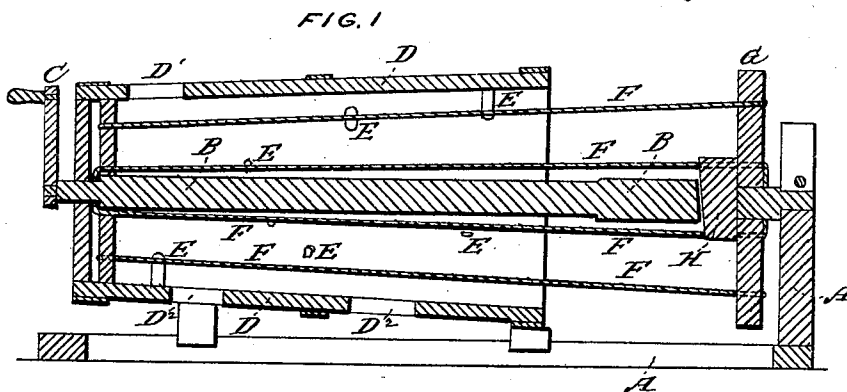

FIG. 1

WITNESSES:

Wm. Clausen
Alfred Eils

INVENTORS:

G. P. Holloway & W. J. Huey
D. P. Holloway & Co
Attys

United States Patent Office.

GEORGE P. HOLLOWAY AND WILLIAM J. HUEY, OF PORTLAND,
INDIANA.

Letters Patent No. 109,903, dated December 6, 1870; antedated November 26, 1870

IMPROVEMENT IN MACHINES FOR BEATING AND CLEANING HAIR.

The Schedule referred to in these Letters Patent and making part of the same.

To all whom it may concern:

Be it known that we, GEORGE P. HOLLOWAY and WILLIAM J. HUEY, of Portland, in the county of Jay and State of Indiana, have invented certain Improvements in Machines for Beating and Cleaning Hair; and we do hereby declare that the following is a full, clear, and exact description thereof, reference being had to the annexed drawing making part of this specification, in which—

Figure 1 is a perspective view of our improved machine, showing the barrel or cylinder in which the material to be operated upon is placed, the cords for cleaning such material, and the movable heads to which such cords are attached.

Figure 2 is a longitudinal sectional elevation, showing the construction of the machine.

Corresponding letters refer to corresponding parts in both figures.

In preparing hair for use in padding saddles, and for various other purposes, it becomes necessary to pass it through some kind of a machine which will separate such portions of it as have become knotted, or in any way joined together in such a manner as to form balls or lumps, and at the same time clean it by liberating from it lime or any other foreign substance which may be united with it.

Our object in the present invention is to provide a reliable machine for the above referred to purposes; and to this end,

It consists in the construction, combination, and arrangement of the parts of which the machine is composed.

To enable those skilled in the art to make and use our invention, we will proceed to describe its construction and operation.

A, in the drawing, refers to the frame-work of the machine, which may be of any suitable form which is adapted to the reception of the barrel or cylinder.

B refers to a shaft, which is located centrally within the cylinder D, its inner end having its bearing in the head of said cylinder, while its outer end is supported by, and revolves in, a standard projecting from frame A.

C refers to a crank, which is placed upon the end of the shaft B, and which may be used for giving motion to the same.

D refers to the barrel or cylinder, which may be of wood or any other suitable material, and of any length and diameter required.

Its smaller end is closed up by a head fitted therein, through which the shaft B projects.

When made of wood this barrel or cylinder is best

made of staves, which are held in position by hoops or bands in the usual way.

It may, however, if preferred, be made in halves or sections, and be held together by hinges or clasps, so that in cleaning, the upper half may be turned back for the purpose of giving access to its interior.

Near the smaller end of this cylinder there is an aperture, D', formed in its upper surface for the insertion of the material to be treated, which aperture may, if preferred, be furnished with a hopper for the reception of such material, while in the lower surface there are two similar apertures for the discharge of the dust or substance which has been beaten or loosened from the hair, such hair being discharged at the large open end of the cylinder.

E E refer to a series of pins which projects from the inner surface of the cylinder to just within the circle described by the cords F during their revolution, so that as each cord passes each pin it shall come in contact therewith, and thus receive a twang for the purpose of more effectually cleaning the hair.

F F refer to a series of cords, which extends from a head or disk placed upon the shaft B, near the smaller end of the cylinder to, and connects with, a disk placed upon the same shaft, at some distance from the larger and open end of said cylinder.

It is apparent that as the shaft B is rotated at a high rate of speed, the material which has been placed in the barrel will be caused by the cords F to be carried from the bottom of the cylinder to the top thereof, when its own gravity will tend to carry it to the bottom again, in doing which it will come in contact with the twanging cords and will thus receive a thorough cleaning.

Any parts thereof which may be carried entirely around the cylinder will also receive the same or a similar treatment.

G refers to a disk, which is placed upon the outer ends of the shaft B and so arranged as to move longitudinally thereon.

To this disk the cords which pass to the disk in the smaller end of the cylinder are attached, so that as the key H, against which the inner side of the disk G rests, is driven through the slot in shaft B prepared for its reception, it (the disk) will be moved outward up on the shaft, and thus any required amount of tension may be put upon the cords.

Having thus described our invention,

What we claim, and desire to secure by Letters Patent, is—

1. The construction of the cylinder D, it having

the projecting pins E E and apertures D' D', substantially as and for the purpose set forth.

2. The combination of the shaft B, the disk G, key H, and cords F F, substantially as and for the purpose set forth.

3. The arrangement of the disk G, key H, shaft B, and cords F F, substantially as and for the purpose set forth.

In testimony whereof, we have signed our names to this specification in the presence of two subscribing witnesses.

GEORGE P. HOLLOWAY.
WILLIAM J. HUEY.

Witnesses:

GEORGE K. ADAIR,
JOSHUA BISHOP.