



US00D689397S

(12) **United States Design Patent**  
**Koyama et al.**

(10) **Patent No.:** **US D689,397 S**  
(45) **Date of Patent:** **\*\* Sep. 10, 2013**

(54) **MOTOR VEHICLE AND/OR TOY REPLICAS THEREOF**

- (71) Applicant: **Toyota Jidosha Kabushiki Kaisha**,  
Toyota (JP)
- (72) Inventors: **Hideo Koyama**, Kariya (JP); **Shun Kawaguchi**, Kariya (JP)
- (73) Assignee: **Toyota Jidosha Kabushiki Kaisha** (JP)
- (\*\*) Term: **14 Years**
- (21) Appl. No.: **29/445,556**
- (22) Filed: **Feb. 13, 2013**

**Related U.S. Application Data**

- (62) Division of application No. 29/394,409, filed on Jun. 16, 2011.

**Foreign Application Priority Data**

Dec. 20, 2010	(JP)	2010-030369
Dec. 20, 2010	(JP)	2010-030374
Dec. 20, 2010	(JP)	2010-030376
Dec. 20, 2010	(JP)	2010-030379

- (51) **LOC (9) Cl.** ..... **12-08**
- (52) **U.S. Cl.**  
USPC ..... **D12/90**
- (58) **Field of Classification Search**  
USPC ..... D12/86, 90-92; D21/424, 433, 434;  
296/181.1, 181.5  
See application file for complete search history.

(56) **References Cited**

**U.S. PATENT DOCUMENTS**

D595,615 S	7/2009	Nagafuchi et al.
D608,694 S	1/2010	Okue et al.

D610,039 S	*	2/2010	Koide et al.	.....	D12/90
D617,684 S		6/2010	Nagura et al.		
D619,047 S	*	7/2010	Foster	.....	D12/91
D619,500 S		7/2010	Hsu et al.		
D624,850 S		10/2010	Yagi et al.		
D628,938 S		12/2010	Yamazaki et al.		
D630,553 S		1/2011	Muller		
D630,554 S		1/2011	Kim		
D633,008 S	*	2/2011	Nakamura et al.	.....	D12/90
D633,823 S		3/2011	Matei et al.		
D642,093 S		7/2011	Kubo et al.		
D647,428 S	*	10/2011	Ohhashi et al.	.....	D12/90
D654,399 S		2/2012	Kumai et al.		
D655,648 S		3/2012	Imaiida et al.		
D657,716 S		4/2012	Cartabiano et al.		

**OTHER PUBLICATIONS**

Toyota, Toyota FT-86 GSports Concept, NetCarShow.com, [http://www.netcarshow.com/toyota/2010-ft-86g\\_sports\\_concept/](http://www.netcarshow.com/toyota/2010-ft-86g_sports_concept/), Oct. 11, 2010.

(Continued)

*Primary Examiner* — Melody Brown

(74) *Attorney, Agent, or Firm* — Saidman DesignLaw Group

(57) **CLAIM**

The ornamental design for a motor vehicle and/or toy replica thereof, as shown and described.

**DESCRIPTION**

FIG. 1 is a left, front perspective view of a motor vehicle and/or toy replica thereof showing our new design;  
 FIG. 2 is a left, rear perspective view thereof;  
 FIG. 3 is a left side elevation thereof, the right side view being a mirror image thereof;  
 FIG. 4 is a top plan view thereof;  
 FIG. 5 is a front elevation view thereof; and,  
 FIG. 6 is a rear elevation view thereof.  
 The broken lines illustrate environmental structure and form no part of the claimed design.

**1 Claim, 3 Drawing Sheets**

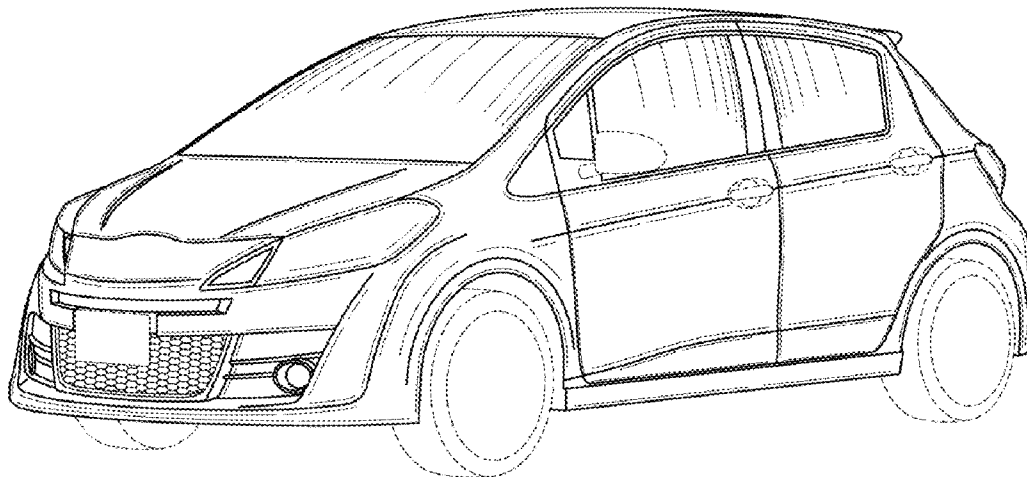

(56)

**References Cited**

OTHER PUBLICATIONS

Fiat, Fiat-500 Abarth, NetCarShow.com, [http://www.netcarshow.com/fiat/2009-500\\_abarth/](http://www.netcarshow.com/fiat/2009-500_abarth/), available at least as early as Jun. 16, 2011.

Subaru, Subaru Impreza WRX STi, NetCarShow.com, [http://www.netcarshow.com/subaru/2008-impreza\\_wrx\\_sti/](http://www.netcarshow.com/subaru/2008-impreza_wrx_sti/), available at least as early as Jun. 16, 2011.

\* cited by examiner

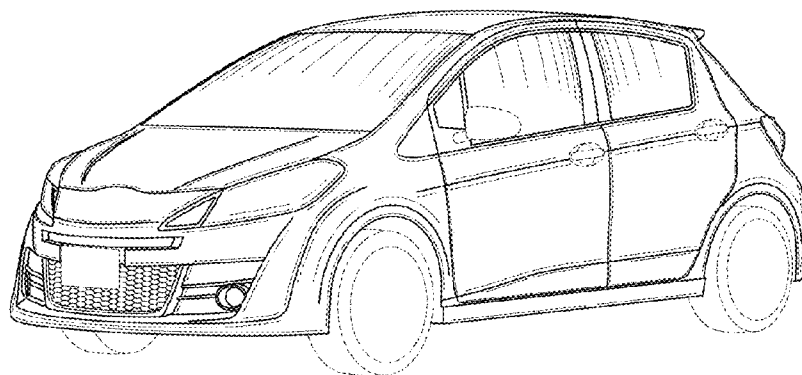

FIG. 1

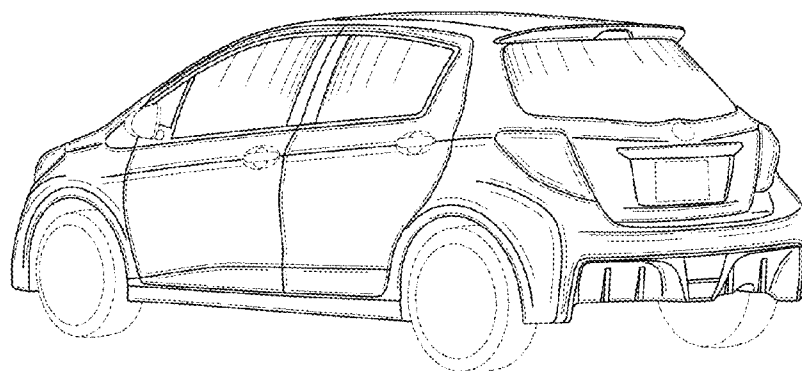

FIG. 2

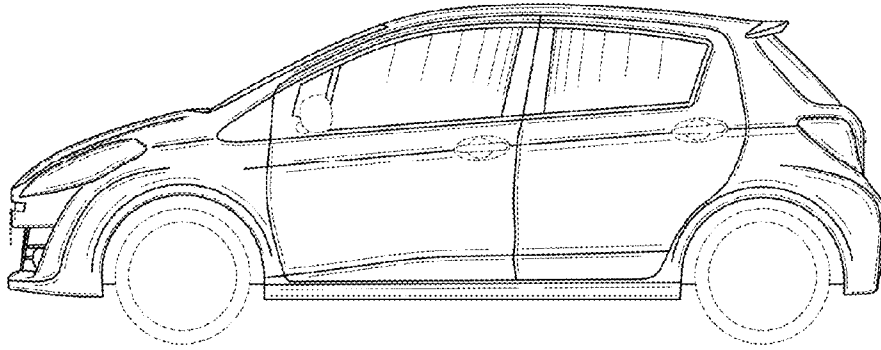

FIG. 3

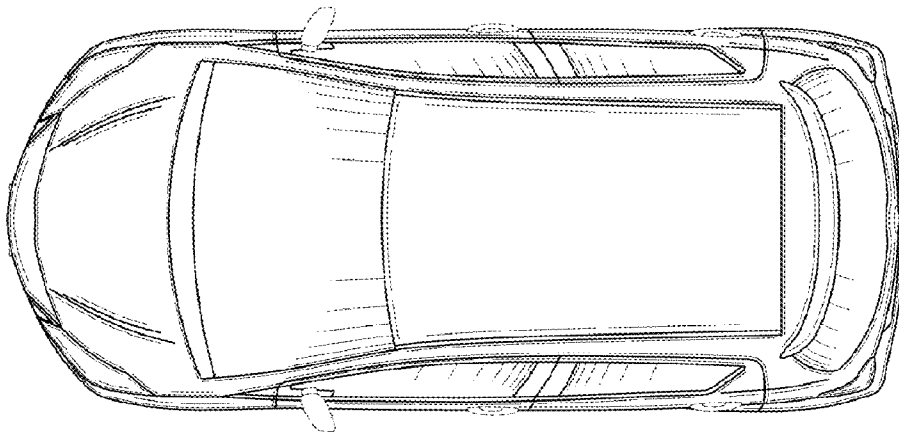

FIG. 4

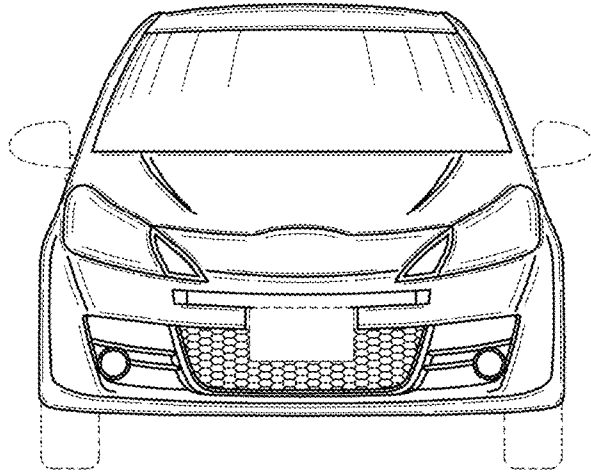

FIG. 5

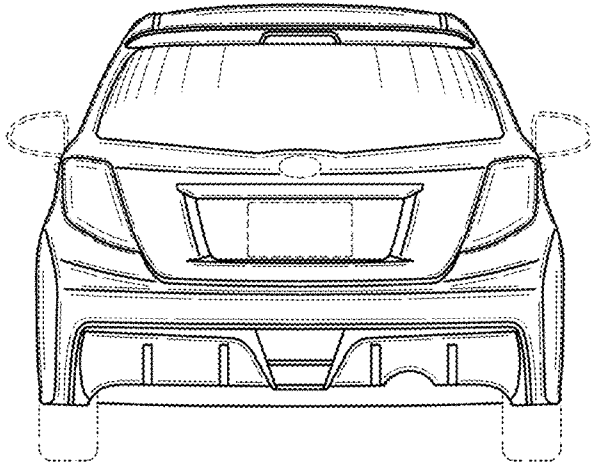

FIG. 6