



US00D765265S

(12) **United States Design Patent** (10) **Patent No.:** **US D765,265 S**
Aston et al. (45) **Date of Patent:** **** Aug. 30, 2016**

(54) **BRIDGE UNIT**
(71) Applicants: **Scott D. Aston**, Liberty Township, OH (US); **Michael R. Blank**, Tacoma, WA (US)
(72) Inventors: **Scott D. Aston**, Liberty Township, OH (US); **Michael R. Blank**, Tacoma, WA (US)
(73) Assignee: **CONTECH ENGINEERED SOLUTIONS LLC**, West Chester, OH (US)
(**) Term: **14 Years**

1,212,452 A * 1/1917 Caldwell E01F 5/005
138/157
1,412,616 A * 4/1922 Kammerer E01F 5/005
138/102
2,803,948 A 8/1957 Dorfman
(Continued)

(21) Appl. No.: **29/499,031**
(22) Filed: **Aug. 11, 2014**

Related U.S. Application Data

(63) Continuation-in-part of application No. 14/321,060, filed on Jul. 1, 2014.

(51) **LOC (10) Cl.** **25-03**
(52) **U.S. Cl.** **D25/1**
USPC **D25/1**

(58) **Field of Classification Search**
USPC D6/657, 661, 661.3, 672-674, 686;
D14/900, 902; D25/1, 2, 13, 15-20,
D25/22, 24, 25, 31-33
CPC A01G 9/14; A01M 31/025; E01F 5/005;
E04B 1/342; E04B 1/343; E04B 1/348;
E04H 1/02; E04H 1/06; E04H 1/12; E04H
1/1222; E04H 1/1244; E04H 1/1266; E04H
1/1272; E04H 1/14; E04H 3/16; E04H 4/00;
E04H 4/148; E02D 17/04
See application file for complete search history.

(56) **References Cited**

U.S. PATENT DOCUMENTS

29,516 A * 8/1860 Parsons E01F 5/005
138/102
1,198,554 A * 9/1916 Jarvey E01F 5/005
138/155

FOREIGN PATENT DOCUMENTS

JP 2005002689 1/2005
SE 0003387 11/2001

OTHER PUBLICATIONS

Barnard, R.J., et al. Water Crossings Design Guidelines, Washington Department of Fish and Wildlife, Olympia, Washington. <http://wdfw.wa.gov/hab/ahg/culverts.htm>, 2013.

(Continued)

Primary Examiner — Anhdao Doan

Assistant Examiner — Clare Ann Gannon

(74) *Attorney, Agent, or Firm* — Thompson Hine LLP

(57) **CLAIM**

The ornamental design for a bridge unit, as shown and described.

DESCRIPTION

FIG. 1 is a perspective view of a bridge unit showing our new design;
FIG. 2 is another perspective view thereof;
FIG. 3 is an end elevation thereof;
FIG. 4 is another end elevation thereof;
FIG. 5 is a cross-section view thereof taken along line 5-5 of FIG. 3;
FIG. 6 is a bottom view thereof; and,
FIG. 7 is another perspective view thereof.
The dash broken lines shown in the drawings are for purposes of illustrating portions of the bridge unit that form no part of the claimed design. The dot-dash broken lines shown in the drawings depict the boundaries of the claim.

1 Claim, 4 Drawing Sheets

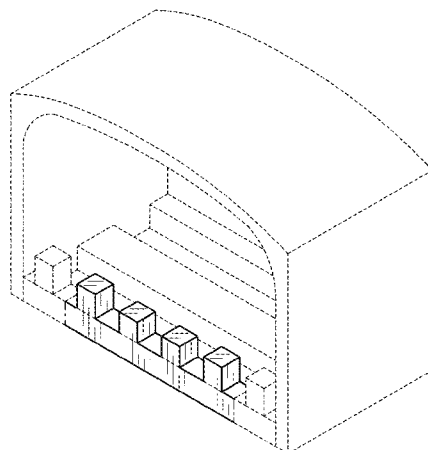

(56)

References Cited

U.S. PATENT DOCUMENTS

3,681,925	A	8/1972	Schmunk et al.	
4,188,154	A	2/1980	Izatt	
4,245,924	A	1/1981	Fouss et al.	
4,360,042	A	11/1982	Fouss et al.	
4,527,319	A	7/1985	Rosenbaum et al.	
4,595,314	A *	6/1986	Lockwood	E01F 5/005 405/124
4,797,030	A *	1/1989	Lockwood	E01F 5/005 405/124
4,854,775	A	8/1989	Lockwood	
5,002,429	A	3/1991	Roberts	
D404,835	S *	1/1999	Stute	D25/16
6,041,829	A	3/2000	Chancellor	
6,517,283	B2	2/2003	Coffey	
6,561,732	B1	5/2003	Bloomfield et al.	
D484,610	S *	12/2003	Lockwood	D25/1
D490,533	S *	5/2004	Lockwood	D25/1
D511,215	S *	11/2005	Vaia	D25/1
D511,387	S *	11/2005	Beach	D25/1
D514,706	S *	2/2006	Beach	D25/1
7,137,756	B1	11/2006	Jones	
8,789,337	B2 *	7/2014	Aston	E02D 29/045 52/293.1
2004/0179899	A1 *	9/2004	VanBuskirk	E02D 29/05 405/124
2005/0123354	A1 *	6/2005	Zax	A01G 9/243 405/124
2007/0099477	A1	5/2007	Burkhart	
2007/0253776	A1 *	11/2007	Robertson	E01F 5/005 405/126
2009/0183321	A1 *	7/2009	Boresi	E01F 5/005 14/4
2009/0279954	A1	11/2009	Griffith et al.	
2010/0226721	A1	9/2010	May et al.	
2011/0044759	A1	2/2011	Lancaster	
2011/0150574	A1	6/2011	Semotiuk et al.	
2011/0255922	A1	10/2011	Elliott	
2012/0009018	A1	1/2012	Marquis et al.	
2013/0071189	A1 *	3/2013	Aston	E01F 5/005 405/126
2014/0305066	A1 *	10/2014	Wilson	E01F 5/005 52/643
2014/0314488	A1 *	10/2014	Aston	E02D 29/045 405/126

OTHER PUBLICATIONS

- B.M. Crookston and B.P. Tullis. A Laboratory Study of Stability in Bottomless Culverts. World Environmental and Water Resources Congress: Restoring Our Natural Habitat, 2007.
- W.R. McKinley and R.D. Webb. A Proposed Correction of Migratory Fish Problems at Box Culverts, Fisheries Research Papers, vol. 1, No. 4, 33-45.
- Katopodis, C., et al. A Study of Model and Prototype Culvert Baffling for Fish Passage, Fisheries and Marine Service Technical Report 828, Dec. 1978, 1-84.
- B.G. Dane. Culvert Guidelines: Recommendations for the Design and Installation of Culverts in British Columbia to Avoid Conflict with Anadromous Fish, Fisheries & Marine Service Technical Report No. 811, Oct. 1978, 1-63.
- Mueller, R.P., et al. Juvenile Coho Salmon Leaping Ability and Behavior in an Experimental Culvert Test Bed, Transactions of the American Fisheries Society, 137:4, 941-950, 2008.
- A.J. Kosicki and S.R. Davis. Consideration of Stream Morphology in Culvert and Bridge Design. Office of Bridge Development, Maryland State Highway Administration. Transportation Research Record 17 43, Paper No. 01-2466, 2001, 57-59.
- State of California, Resources Agency, Department of Fish and Game, Culvert Criteria for Fish Passage, May 2002, 1-17.
- Poplar-Jeffers, I.O., et al. Culvert Replacement and Stream Habitat Restoration: Implications from Brook Trout Management in an Appalachian Watershed, U.S.A., Restoration Ecology vol. 17, No. 3, pp. 404-413, May 2009.
- C.M. Frei and R. H. Hotchkiss. Design and Assessment Techniques for Fish Passage at Culverts and Bridges, World Environmental and Water Resources Congress 2006.
- B.C. Singley and R.H. Hotchkiss. Differences between Open-Channel and Culvert Hydraulics: Implications for Design, World Environmental and Water Resources Congress 2010: 1278-1287.
- Bryant, M.D., Evaluation of a Small Diameter Baffled Culvert for Passing Juvenile Salmonids, United States Department of Agriculture, Forest Service, Pacific Northwest Forest and Range Experiment Station, Research Note, PNW-384, Apr. 1981.
- Norman, J.M., et al. Technical Report Documentation Page Hydraulic Design of Highway Culverts, Second Edition, Office of Bridge Technology, National Highway Institute, FHWA-NHI-020 HDS No. 5, Sep. 2001 (Revised May 2005).
- Ecklund, Eileen, Fish Passage Removed From Streams: Making Way For Salmon; Government Publications/California—California Coast & Ocean vol. 25 Issue 2; 2009; pp. 26-27.
- Feurich, Roberg, et al. Ecological Engineering: Improvement of Fish Passage in Culverts using CFD; Ecological Engineering 47 (2012) 1-8; Department of Hydraulic and Environmental Engineering.
- Culvert Criteria for Fish Passage, State of California, Resources Agency, Department of Fish and Game, May 2002; pp. 1-17.
- Ead, S.A. et al., Generalized Study of Hydraulics of Culvert Fishways, Journal of Hydraulic Engineering/Nov. 2002, pp. 1018-1022.
- Culvert Design for Aquatic Organism Passage, Hydraulic Engineering Circular No. 26, First Edition, U.S. Department of Transportation, Federal Highway Administration; Publication No. FHWA-HIF-11-008, Oct. 2010, 234 pages.
- Mozes, Katheryn M., Hydraulic Stream-Simulation Design Option for Culvert Construction in Eastern Washington to Meet Fish Passage Criteria; How Big Is Enough?, Washington State University, Department of Civil and Environmental Engineering, Aug. 2008, 144 pages.
- Rajaratnam, N., et al., Hydraulics of Culvert Fishways II: Slotted-Weir Culvert Fishways, Canada Journal of Civil Engineering, vol. 16, 1989, pp. 375-383.
- Rajaratnam, N., et al., Hydraulics of Culvert Fishways III: Weir Baffle Culvert Fishways, Canada Journal of Civil Engineering, vol. 17, 1990, pp. 558-568.
- Rajaratnam, N., et al., Hydraulics of Culvert Fishways IV: Spoiler Baffle Culvert Fishways, Canada Journal of Civil Engineering, vol. 18, 1991, pp. 76-82.
- Rajaratnam, N., et al., Hydraulics of Culvert Fishways V: Alberta Fish Weirs and Baffles; Canada Journal of Civil Engineering, vol. 17, 1990, pp. 1015-1017.
- Thurman, David R., et al., Hydrodynamics of Juvenile Salmon Passage in Sloped-Baffle Culverts, World Environmental and Water Resources Congress 2006, pp. 1-10.
- Olsen, A.H., et al., Laboratory Study of Fish Passage and Discharge Capacity in Slip-Lined, Baffled Culverts, 2013 American Society of Civil Engineers, Journal of Hydraulic Engineering© ASCE/Apr. 2013, pp. 424-432.
- Rajaratnam, N., et al., Hydraulics of Offset Baffle Culvert Fishways, Canadian Journal of Civil Engineering, vol. 15, 1988, pp. 1043-1051.
- Alvarez-Vazquez, et al., On the Optimal Design of River Fishways, Published online: Nov. 4, 2011, © Springer Science+ Business Media, LLC 2011, Optim Eng (2013) 14:193-211.
- Parola, Jr., Arthur C., Pool Simulation Culvert Design for Fish Passage, World Environmental and Water Resources Congress 2008 Ahupua'am, © 2008 ASCE, pp. 1-9.
- Hays, Matthew D., et al., Fish Passage Can Be Improved by Introducing Hydraulic Refuge. Can The Effects Be Quantified?, World Environmental and Water Resources Congress 2009: Great Rivers© 2009 ASCE, pp. 3092-3106.
- David, B.O., et al., Remediation of a Perched Stream Culvert With Ropes Improves Fish Passage, Marine and Freshwater Research, 2012, 63-440-449, CSIRO Publishing.
- Slawski, Thomas M. & Ehlinger, Timothy J. (1998): Fish Habitat Improvement in Box Culverts: Management in the Dark?, North American Journal of Fisheries Management, 18:3, 676-685.

(56)

References Cited

OTHER PUBLICATIONS

Franklin, Paul A., et al., Restoring Connectivity for Migratory Native Fish in a New Zealand Stream: Effectiveness of Retrofitting a Pipe Culvert, *Aquatic Conserv: Mar. Freshw. Ecosyst.* 22:489-497 (2012).

Crookston, B.M., et al., Scour Prevention in Bottomless Arch Culverts, *International Journal of Sediment Research*, vol. 27, No. 2, 2012. pp. 213-225.

Wargo, Rebecca S., et al., A Comparison of Single-Cell and Multicell Culverts for Stream Crossings, *Journal of the American Water Resources Association*, Aug. 2006, pp. 989-995.

Morrison, Ryan R., et al., Turbulence Characteristics of Flow in a Culvert With Sloped-Weir Baffles, *World Environmental and Water Resources* 2006, © ASCE 2006, pp. 1-10.

Morrison, Ryan, R., et al., Turbulence Characteristics of Flow in a Spiral Corrugated Culvert Fitted With Baffles and Implications for Fish Passage, *Ecological Engineering* 35 (2009) pp. 381-392.

Pearson, W.H., Evaluation of Juvenile Salmon Leaping Ability and Behavior at an Experimental Culvert Test Bed, Final Rpt, Jun. 2005, Washington State Department of Transportation, WSDOT Agreement No. GCA2677, Battelle Pacific Northwest Division, Richland, Washington: (PNWD-3539).

MacDonald, J.I., et al., Improving the Upstream Passage of Two Galaxiid Fish Species Through a Pipe Culvert, *Fisheries Management and Ecology*, 2007, 14, 221-230, (© 2007 The Authors, Journal compilation © 2007 Blackwell Publishing Ltd.).

Fitch, G. Michael, Nonanadromous Fish Passage in Highway Culverts, Final Report, Virginia Transportation Research Council, Rept. No. VTRC 96-R6, Oct. 1995, 18 pgs (Project No. 3041-010).

Goodridge, Wade, H., Sediment Transport Impacts Upon Culvert Hydraulics, Utah State University, Logan Utah, 2009, 381 pages.

* cited by examiner

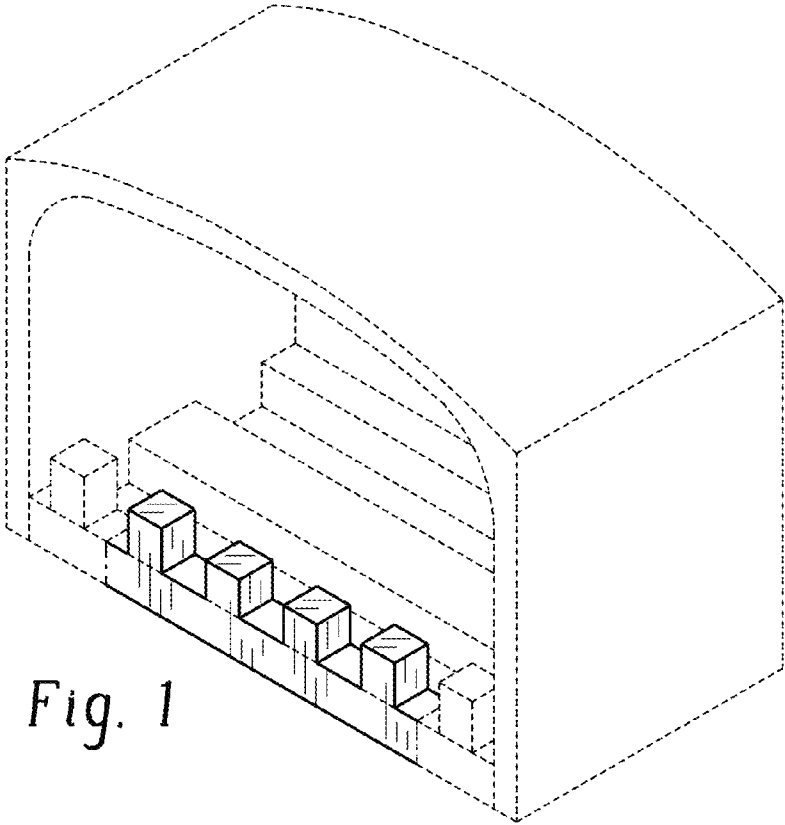

Fig. 1

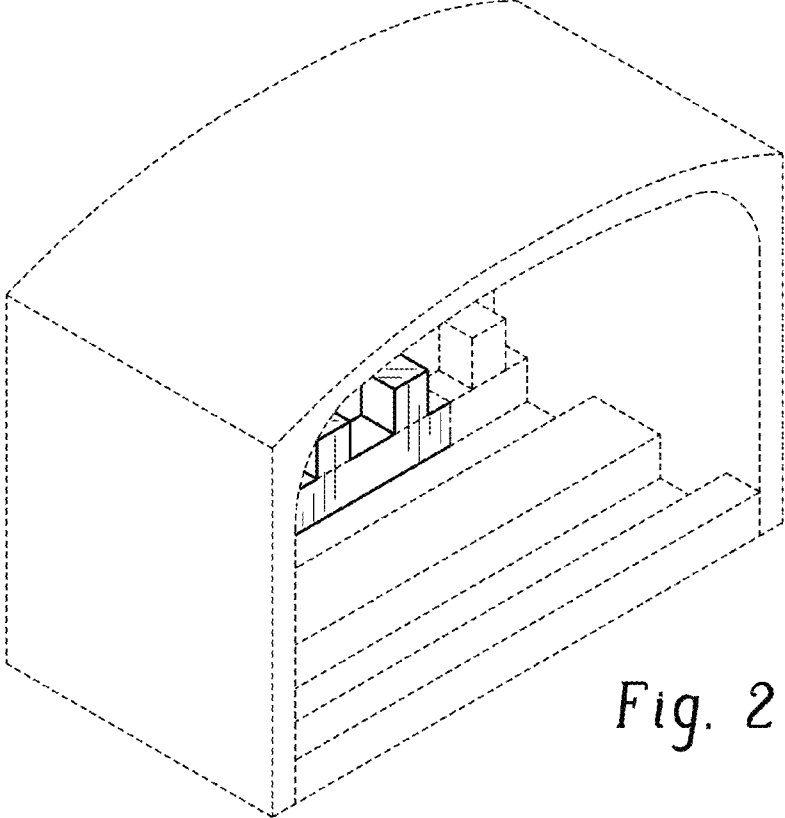

Fig. 2

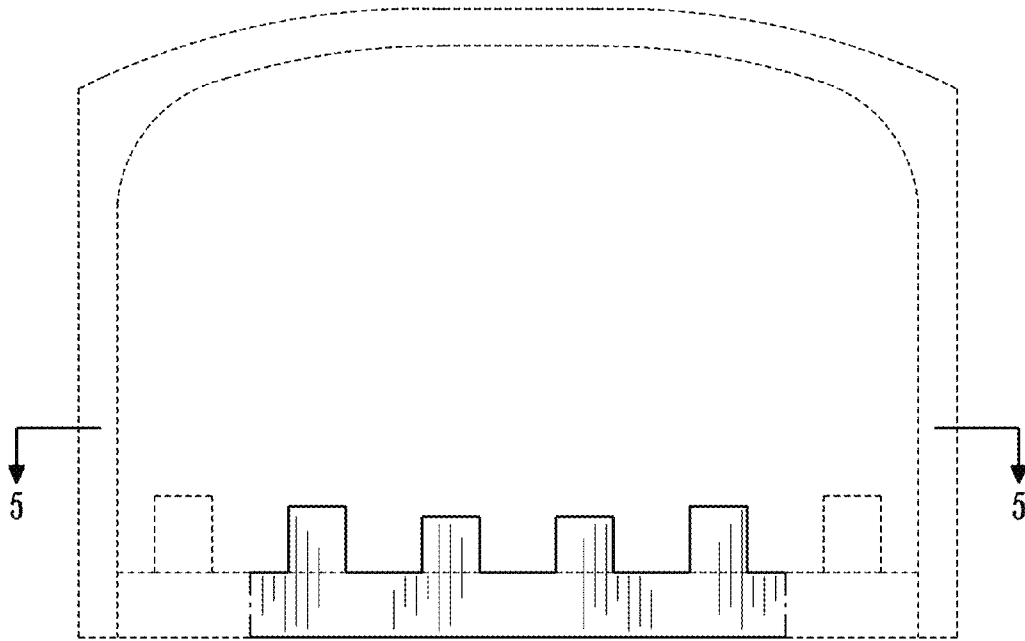

Fig. 3

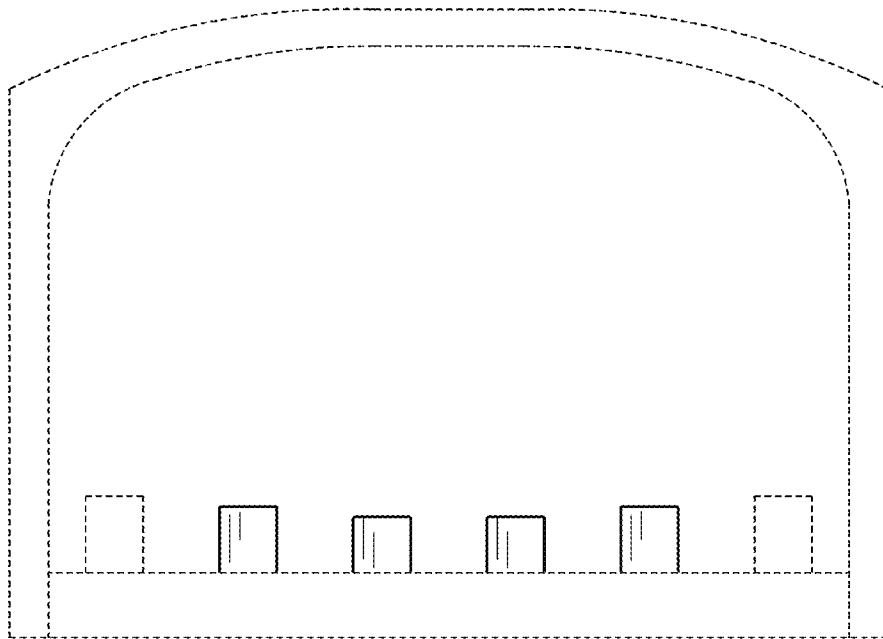

Fig. 4

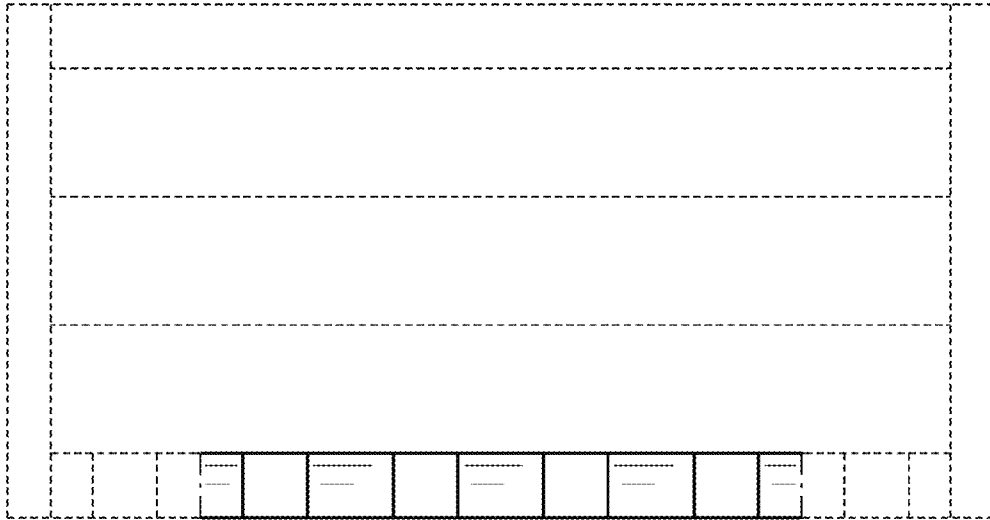

Fig. 5

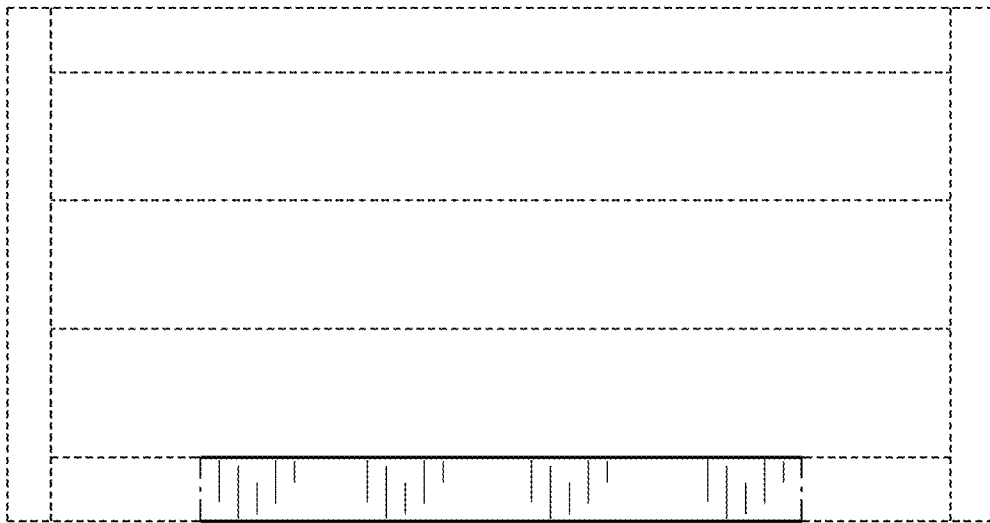

Fig. 6

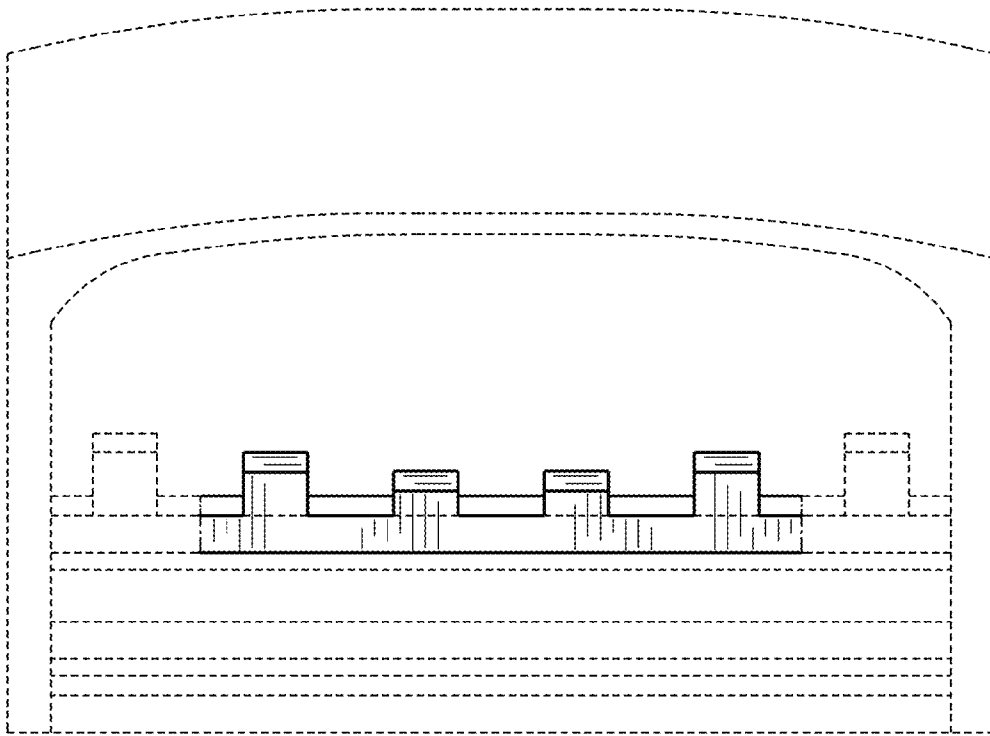

Fig. 7