

(19)



(11)

**EP 4 006 295 B1**

(12)

**EUROPEAN PATENT SPECIFICATION**

(45) Date of publication and mention of the grant of the patent:  
**19.02.2025 Bulletin 2025/08**

(51) International Patent Classification (IPC):  
**E06B 9/50 (2006.01) E06B 9/17 (2006.01)**  
**E06B 9/171 (2006.01) E06B 9/42 (2006.01)**

(21) Application number: **21210859.1**

(52) Cooperative Patent Classification (CPC):  
**E06B 9/50; E06B 9/17007; E06B 9/174; E06B 9/42;**  
**E06B 9/58; E06B 2009/2476**

(22) Date of filing: **26.11.2021**

(54) **A SCREENING ARRANGEMENT FOR A ROOF WINDOW, AND ROOF WINDOW COMPRISING SUCH A SCREENING ARRANGEMENT**

ABSCHIRMVORRICHTUNG FÜR EIN DACHFENSTER UND DACHFENSTER MIT EINER SOLCHEN ABSCHIRMVORRICHTUNG

AGENCEMENT DE PROTECTION POUR UNE FENÊTRE DE TOIT, ET FENÊTRE DE TOIT COMPRENANT UN TEL AGENCEMENT DE PROTECTION

(84) Designated Contracting States:  
**AL AT BE BG CH CY CZ DE DK EE ES FI FR GB GR HR HU IE IS IT LI LT LU LV MC MK MT NL NO PL PT RO RS SE SI SK SM TR**

(72) Inventors:  
• **ANGEL, Beatrice**  
**2970 Hørsholm (DK)**  
• **HESTBÆK, Allan Dalsgaard**  
**2970 Hørsholm (DK)**

(30) Priority: **27.11.2020 DK PA202070797**

(74) Representative: **AWA Denmark A/S**  
**Strandgade 56**  
**1401 Copenhagen K (DK)**

(43) Date of publication of application:  
**01.06.2022 Bulletin 2022/22**

(73) Proprietor: **VKR Holding A/S**  
**2970 Hørsholm (DK)**

(56) References cited:  
**EP-A1- 3 327 240 EP-A2- 2 236 731**  
**EP-B1- 2 094 931 DE-U1- 8 900 259**

**EP 4 006 295 B1**

Note: Within nine months of the publication of the mention of the grant of the European patent in the European Patent Bulletin, any person may give notice to the European Patent Office of opposition to that patent, in accordance with the Implementing Regulations. Notice of opposition shall not be deemed to have been filed until the opposition fee has been paid. (Art. 99(1) European Patent Convention).

## Description

### Technical Field

[0001] The invention relates to a screening arrangement according to the preamble of claim 1. The invention furthermore relates to a roof window comprising such a screening arrangement.

### Background Art

[0002] Screening arrangements also must fulfil different requirements depending on whether they are installed in a façade window, i.e. in a substantially vertical position, or in an inclined or even horizontal surface such as a roof.

[0003] Not only are screening arrangements for roof windows configured to take into account the effects of gravity due to the resulting force being out of the general plane of the roof window, but the mounted position itself, on a roof, puts large demands to the components of the external screening arrangement.

[0004] In known prior art screening arrangements, the manufacturing of the screening arrangement may be quite a complicated process with small margins for errors. For example, small clearances may be present during assembly, e.g. when connection or otherwise introducing components into each other. These small clearances may lead to nicks and bump being created by unwanted contact in-between components. Alternatively, an additional amount of time or steps is needed to avoid the small clearances being problematic.

[0005] A prior art screening arrangement of the kind mentioned in the preamble of claim 1 is shown and described in EP 2 236 731 A2.

### Summary of Invention

[0006] With this background, it is therefore an object of the invention to provide a screening arrangement, which eases manufacturing of the screening arrangement.

[0007] In a first aspect, this and further objects are achieved by a screening arrangement of the kind mentioned in the introduction, which is furthermore characterised in that the screening arrangement comprises a winding device comprising at least one winding reel in connection with or connectable to the roller bar at the first longitudinal end of the roller bar, that the top casing comprises a bottom end element and a top end element adjacent to the first longitudinal end of the roller bar and further delimiting the bar space, the bottom end element and the top end element delimiting a reel space accommodating and limiting movement of the at least one winding reel, and that the bottom element of the top casing is configured to receive and support the roller bar during assembly of the screening arrangement and the top element is configured to be connected to the bottom element subsequent to the bottom element receiving

the roller bar.

[0008] Consequently, by firstly supporting the roller bar on the bottom element and then subsequently connecting the top element the ease of assembling the top casing is improved. The roller bar does not need to be introduced along an opening in the top casing, instead the top casing is formed around the roller bar. Thus, the handling of the roller bar is eased during assembly of the screening arrangement. Since the winding device comprising a winding reel at one or both ends of the roller bar is present, the formation of a space limiting movement of the winding reel, the assembly of the screening device is further eased as the risk of unwanted movement of winding reel(s) during assembly is minimized.

[0009] In an embodiment the at least one winding reel comprises engagement means adapted for connecting the at least one winding reel to the roller bar, wherein the bottom end element and the top end element are configured to form an engagement through-hole extending from the reel space to the bar space, and wherein the engagement means extends through the engagement through-hole and into the roller bar. Consequently, the top casing is formed in a simple and efficient manner where movement of the winding reel and the roller bar is limited, while still allowing the roller bar and the winding reel to be connected to each other.

[0010] In an embodiment the engagement means are formed as one or more snap-legs engaged in a snap-connection with one or more corresponding connectors in the roller bar. Consequently, the winding reel may be connected to the roller bar by simply inserting the engagement means into the roller bar. The connection between the roller bar and the winding reel does not need tools for being formed, thus simplifying assembly, and obviating the need for additional space to accommodate a tool.

[0011] In an embodiment, the top casing comprises an end cover further delimiting the reel space. In addition to providing closure of the interior of the top casing such that dust and other contaminants are hindered from negatively affecting the winding reel, the end cover may also provide support for the winding reel.

[0012] In an embodiment a through-hole is formed in the end cover aligned with the engagement through-hole formed by the bottom end element and the top end element to allow drive means to be inserted through the through-hole and the engagement through-hole into the roller bar. Thus, it is for instance possible to include a motor unit to be connected to one end cover, whereas the other end cover is of a more simple structure.

[0013] In a further development of the embodiment comprising one or two end covers, the end cover comprises one or more second support surfaces supporting the winding reel and facilitating rotation of the winding reel in the winding direction and the unwinding direction. This ensures suitable rotational support for the winding reel.

[0014] In an embodiment the bottom end element an-

d/or the top end element comprises one or more first support surfaces supporting the winding reel and facilitating rotation of the winding reel in the winding direction and the unwinding direction. Consequently, movement of the winding reel is facilitated, which in return facilitates movement of a screening body.

**[0015]** In principle, the top and bottom elements may be connected to each other in any suitable way, as long as they allow for initial reception of the roller bar by the bottom element during assembly. In an embodiment, the bottom end element is connected to the bottom element and the top end element, wherein the top end element is connected to the top element, and wherein the bottom element is connected to the top element via the bottom end element and the top end element. This facilitates the assembly of the screening arrangement even further.

**[0016]** In further embodiments, the bottom end element and the top end element each comprises a plurality of connectors for connecting the bottom end element to the bottom element and for connecting the top end element to the top element. Suitable connectors include releasable engagement means including screws and openings, but could also include snap or frictional engagements means.

**[0017]** In one embodiment, the bottom end element is connected to the top end element by a set of connectors, preferably including a first, pivotal connection, more preferably also in a also in second, releasable connection. A pivotal connection provides for a particularly simple mounting, since the elements are easily fit into the assembled position.

**[0018]** In a further embodiment, the winding device forms part of a cord system comprising a set of cords, the at least one winding reel, and optionally return elements and/or tightening means for the cords. The cord or cords of the cord system may either be wound on the winding reel before assembly of the winding reel with the respective end of the roller bar, or later, i.e. once the winding reel is located in the reel space. Typically, two winding reels are present, one at each longitudinal end of the roller bar.

**[0019]** While the screening arrangement could in principle be used to screen an arbitrary opening, it is preferred that the screening arrangement is adapted for a skylight or roof window. In such structures, the possible assistance from gravity forces during unwinding of the screening body is negligible.

**[0020]** In a second aspect of the invention the objects set forth are achieved by a method for assembling a top casing with a roller bar for a screening arrangement, comprising the steps of:

- providing a bottom element, a top element and a roller bar,
- providing a bottom end element and a top end element,
- supporting the roller bar on the bottom element,

fixedly connecting the bottom end element to the bottom element,

pivotaly connecting the bottom end element to the top end element, wherein the top end element is pivotal between an open state and a closed state, fixedly connecting, when the top end element is in the closed state, the top end element to the top element and thereby

enclosing the roller bar by connecting the top element to the bottom element, wherein a bar space is formed in-between the bottom element and the top element, and wherein the bar space accommodates and limits movement of the roller bar.

**[0021]** Other presently preferred embodiments and further advantages will be apparent from the subsequent detailed description and drawings.

**[0022]** A feature described in relation to one of the aspect may also be incorporated in the other aspect, and the advantage of the feature is applicable to all aspects in which it is incorporated.

#### Brief Description of Drawings

**[0023]** For exemplifying purposes, the invention will be described in closer detail in the following with reference to embodiments thereof illustrated in the attached drawings, wherein:

Fig. 1 is a perspective view of a screening arrangement in a first embodiment of the invention;

Figs 2 and 3 are perspective views of screening arrangements in other embodiments of the invention;

Fig. 4 is a perspective, partially sectioned view of a screening arrangement in the first embodiment of the invention installed in a roof window mounted in a roof structure;

Fig. 5 is an exploded, perspective schematic view of a right-hand side of a top casing with a roller bar according to an embodiment of the invention.

Fig. 6 is a perspective schematic view of a bottom end element and a top end element in an assembled state according to an embodiment of the invention.

Fig. 7 is a schematic cross-sectional view of a bottom element and a top element according to an embodiment of the invention.

Fig. 8 is a partially exploded perspective schematic view of a right-hand side of a top casing with a roller bar according to an embodiment of the invention.

Figs 9 and 10 are perspective schematic views of a bottom end element and a top end element, where the end element is in an open state, according to an embodiment of the invention.

Figs 11 and 12 are different perspective schematic views of an end cover according to an embodiment of the invention.

Figs 13a and 13b are different perspective sche-

matic views of an end cover according to another embodiment of the invention.

Fig. 14 is an exploded perspective view of details of an embodiment of a screening arrangement including drive means comprising a motor unit.

Figs 15a to 15e are perspective schematic views of the right-hand corner of a top casing at different stages of assembly.

Fig. 16 is a perspective view of a cord system forming part of an embodiment of the screening arrangement according to the invention.

Fig. 17 is an exploded partial perspective view of details of a screening arrangement in an embodiment of the invention.

### Description of Embodiments

**[0024]** In the following detailed description, preferred embodiments of the present invention will be described. However, it is to be understood that features of the different embodiments are exchangeable between the embodiments and may be combined in different ways, unless anything else is specifically indicated. It may also be noted that, for the sake of clarity, the dimensions of certain components illustrated in the drawings may differ from the corresponding dimensions in real-life implementations.

**[0025]** It is noted that terms such as "up", "down", "left-hand", "right-hand", "exterior", "interior", "outer", "inner" are relative and refers to the viewpoint in question.

**[0026]** Referring initially to Figs 1 and 4, a first embodiment of a screening arrangement 50 is shown. The screening arrangement 50 is configured to be installed in a roof window 1 installed in an inclined or flat roof 2 of a building to cover an opening 1a of the roof window 1 in a mounted condition of the screening arrangement 50. The opening 1a of the roof window 1 is positioned opposite an opening 2a provided in the roof 2. By the term roof window is in principle meant any window suitable for being installed in a roof. By flat roof is generally meant roofs having an inclination of 0 to 5° and by inclined roofs inclinations larger than 5°, for instance up to 45° or 65°.

**[0027]** The screening arrangement 50 comprises a screening device 60 including a top casing 61 and a screening body 65 having two side edges, a first end portion and a second end portion. The screening body 65 is movable in a longitudinal direction between a non-screening position, in which the screening body 65 is substantially accommodated in the top casing 61, and a number of screening positions in which the screening body 65 is deployed from the top casing 61 and covers the opening partially or entirely. The screening body 65 may take the form of a flexible cloth which is rolled up when accommodated in the top casing and is substantially plane when rolled out in a deployed screening position. The screening body may be opaque to form a darkening or blackout blind or admit a certain amount of incoming light in the screening position, for instance as in an

awning blind. Regardless of the configuration, the screening body 65 defines a screening plane when deployed to a screening position. The first end portion of the screening body 65 is connected to a roller bar 61r (cf. for instance Fig. 5) accommodated in the top casing 61 and its other end portion is in the embodiment shown connected to a bottom bar 66. While reference to a blind which is rolled-up in the non-screening position is made in the above and throughout the embodiments of the invention, the principles of the invention are applicable also to other types of screening devices such as for instance a pleated blind, being folded up when accommodated, or a Venetian blind or other screens including a number of lamellas forming the screening body and which are collected on a collection device equivalent to the roller bar 61r, when accommodated in the top casing 61.

**[0028]** The screening device 60 furthermore comprises two side rails 63, 64 configured to extend substantially perpendicularly to the top casing 61 in the mounted condition of the screening arrangement 50 and which guide the side edges of the screening body 65 during its movement to and from its deployed positions. Together, the top casing 61 and the two side rails 63, 64 define an outer perimeter of the screening device 60. In the first embodiment shown in Figs 1 and 4, the screening device 60 comprises a bottom profile 62 which is shown in a position connected to the side rails 63, 64. The connection between the two side rails 63, 64 and the top casing 61 at one end and the bottom profile 62 at the other advantageously takes place before installing the screening device 60 in the roof window 1, as the screening device 60 may for instance be delivered in a supply condition in which the two side rails 63, 64, the top casing 61 and the bottom profile 62 are packaged in parallel with each other.

**[0029]** In order to move the screening body 65 from the non-screening position to a screening position and back, the screening arrangement 50 is in the first embodiment provided with a solar panel 61s placed in the top casing 61 which could be used to power the screening arrangement 50, possibly connected to a battery inside the top casing 61; however, power may also be provided from a main housing supply, as indicated in the alternative embodiments of Figs 2 and 3, where no solar panel is present. Wiring, motor control and power means for the motor are not shown in either of the embodiments.

**[0030]** The screening device 60 thus forms a rectangular shape having a closed configuration in the first embodiment of Figs 1 and 4. In the alternative embodiments of Figs 2 and 3, it is noted that no bottom profile is present. While the shape of the screening device 60 in each of these alternative embodiments is rectangular, the configuration is open in the form of a U. When seen in the general plane of the screening device 60 as defined by its screening body, an outer perimeter of the screening device 60 is formed by peripherally outermost surfaces of the top casing 61, the two side rails 63, 64 and, if present, the bottom profile 62, or, if no bottom profile is

present, by a line extending between the free ends of the side rails 63, 64.

**[0031]** The screening arrangement 50 furthermore comprises a suspension device 70 connected to or connectable to the screening device 60 as will be described in further detail below. The suspension device 70 comprises means for connecting the screening device 60 to the roof window 1 in that the suspension device 70 of the screening arrangement comprises a plurality of flanges associated to a respective one of the top casing 61 and the two side rails 63, 64 of the screening device 60, and, if present, to the bottom profile 62. In Fig. 4, flanges 71, 72 and 74 are visible.

**[0032]** Each flange 71, 72, 74 defines at least one line of contact of the suspension device 70 intended to cooperate with a corresponding component of the roof window 1 in the mounted condition of the screening arrangement 50. In Fig. 4, three such lines of contact LC1, LC2 and LC4 are shown. It is understood that a corresponding line of contact is present at the flange 73 connected to the other side rail 63.

**[0033]** It is noted that each flange 71, 72, 74 of the suspension device 70 is configured to protrude from the respective one of the top casing 61 and the two side rails 63, 64 and the bottom profile 62 such that the lines of contact LC1, LC2, LC4 are positioned to the outer side of an outer perimeter of the screening device 60 in the mounted condition of the screening arrangement, i.e. outside the outer perimeter or periphery of the components of the screening device 60 as described in the above.

**[0034]** The side rails 63, 64 are formed as longitudinally extending profiles which are cut transversely to the length direction to form blunt opposing ends. Due to the configuration of the top casing 61 and the width of the side rails 63, 64 an opening is formed at the corners in-between the top casing 61 and the two side rails 63, 64, when seen perpendicularly to the screening plane.

**[0035]** In order to ensure that dust and other contaminants enter the top casing and/or the side rails, the screening arrangement 50 furthermore comprises a corner cover assembly 80 to interact with the screening device 60 and the suspension device 70 in the mounted condition of the screening arrangement. The corner cover assembly 80 also provides light-proofing in that it hinders light from passing the screening arrangement. This is most important in connection with blackout screening devices, as it blocks the openings formed in the screening arrangement, thus hindering the passage of light through the screening arrangement and further into the interior of the room of the building.

**[0036]** In the first embodiment, the corner cover assembly 80 comprises a first and a second corner cover element 81, 82 to interact with the top casing 61 and the two side rails 63, 64 of the screening device 60 and with a respective flange 71, 73, 74 of the plurality of flanges of the suspension device 70 such that the intersection between adjacent lines of contact LC1, LC2, LC4, or

extensions of the lines of contact, is located below a respective one of the first and second cover element 81, 82 in the mounted condition of the screening arrangement. Furthermore, a third and a fourth corner cover element 83, 84 is provided to interact with the side rails 63, 64 and the bottom profile 62 of the screening device 60 and with a respective flange 73, 74 of the suspension device 70. This configuration also applies to the alternative embodiment of Fig. 2, whereas in the embodiment of Fig. 3, no third or fourth cover elements are present.

**[0037]** Turning now in particular to Fig. 4, the roof window 1 comprises a window portion 4 with a window sash 6 and an insulating glazing unit 5. The sash 6 comprises opposing first and second sash members 11, 12 and opposing third and fourth sash members, of which the fourth sash member 14 is shown in Fig. 4, encasing the insulating glazing unit 5. The sash 6 is connected to a frame 7 comprising four frame members 10. The shape of the sash 6 and frame 7 is thus rectangular, for instance square. The sash 6 may be openable relative to the frame 7 or fixed.

**[0038]** The roof window 1 furthermore comprises a weather shield 3 positioned above the insulating glazing unit 5 and comprising a weather shield pane 8 and a skirt 9. The weather shield 3 has been moved out of engagement with the window portion 4 in Fig. 4 for reasons of clarity. The weather shield pane 8 is substantially plane; however, it is conceivable to install the screening arrangement 50 also in roof windows having a curved pane. The weather shield 3 may be openable relative to the window portion 4 or fixed.

**[0039]** The screening arrangement 50 is arranged in a spacing between an exterior surface of the insulating glazing unit 5 of the window portion 4 and an interior surface of the weather shield pane 8 of the weather shield 3 such that the screening device 60 is located below an exterior side of the first sash member 11 in the mounted condition of the screening arrangement 50.

**[0040]** Referring to Fig. 5 showing an exploded, perspective schematic view of a right-hand side of the top casing 61 with the roller bar 61r according to an embodiment of the screening arrangement 50 of the invention.

**[0041]** The top casing 61 comprises a bottom element 61a. The bottom element 61a extends longitudinally to form part of a bar space 61p for receiving the roller bar 61r. A top element 61b extends longitudinally in parallel with the bottom element 61b. The top element 61b in the assembled condition of the screening arrangement 50 delimits the bar space 61p together with the bottom element 61a.

**[0042]** The screening arrangement comprises a winding device comprising a winding reel 671. The winding reel 671 comprises a winding track 675 for accommodating a cord 67c, see Fig. 16. The winding reel 671 and the cord 67c here form part of a cord system 67 for moving the screening body 65 along the side rails 63, 64. In the embodiment shown in Fig. 16, two cords 67c are provided to extend from the bottom bar 66 to the winding reel 671 at

the respective longitudinal end 61r1 and 61r2 of the roller bar 61r, via a return element such as a pulley or the like (not indicated) provided at or near the ends of the side rails opposite the top casing 61, possibly provided in the bottom profile 62, if present. Tightening means (not shown) may also be provided to keep the cord or cords 67c of the cord system 57 tightened. The winding track 675 is delimited by a first winding flange 673 and a second winding flange 674. The first winding flange 673 and the second winding flange 674 extend from a perimeter of the winding track 675. Extending in parallel with bottom element 61a and the top element 61b is engagement means 672 for connecting the winding reel 671 to the roller bar 61r. The engagement means are in the embodiment shown formed as one or more snap-legs, here three snap-legs 672. The snap-legs 672 are configured to engage one or more roller bar connectors 61r3 arranged in the roller bar 61r in a snap connection.

**[0043]** The roller bar 61r extends longitudinally between a first longitudinal end 61r1 and a second longitudinal end 61r2. In the assembled state, the roller bar 61r extends longitudinally in parallel with the bottom element 61a and the top element 61b.

**[0044]** The top casing 61 further comprises a bottom end element 611a and a top end element 611b. In an assembled state of the top casing 61 the bottom end element 611a and the top end element 611b are arranged adjacent to the first longitudinal end 61r1 of the roller bar 61r and further delimit the bar space 61p together with the bottom element 61a and the top element 61b. The bottom end element 611a and the top end element 611b delimit a reel space 61w. In the assembled state at least, part of the winding reel 671 is arranged within the reel space, preferably the track 675, the first winding flange 673 and the second winding flange 674. The reel space 61w is intended for accommodating and limiting movement of the at least one winding reel 671.

**[0045]** In the embodiment shown, the top casing 61 is closed off by a set of end covers. One end cover 613R is shown in Fig. 5 and further delimits the reel space 61w. An opposite end cover 613L is present at the opposite longitudinal end of the top casing. Although not shown in detail, a counterpart winding reel is in engagement with a bottom end element and a top end element at the opposite end. Consequently, the winding reel 671 received in the reel space 61w is kept from moving unnecessarily in the longitudinal direction by the end covers 613R and 613L, and the respective bottom end element 611a and the top end element 611b. In the rotational direction, the winding reel 671 is rotationally supported by the respective end cover 613R, 613L and the bottom end element 611a and top end element 611b as will be described in further detail below.

**[0046]** Referring to Fig. 6 and 7, where Fig. 6 shows a perspective schematic view of a bottom end element 611a and a top end element 611b in an assembled state according to an embodiment of the invention, and Fig. 7 shows a schematic cross-sectional view of a bottom

element 61a and a top element 61b of the top casing 61.

**[0047]** The bottom end element 611a comprises a plurality of connectors for connecting the bottom end element 611a to the bottom element 61a. The connectors may be configured for providing a screw or snap connection between the bottom end element 611a and the bottom element 61a.

**[0048]** In the shown embodiment, the connectors of the bottom end element 611a comprise two bottom connection openings 612a, 619a for facilitating a screw connection between the bottom end element 611a and the bottom element 61a. In the shown embodiment, the bottom connection openings 612a, 619a are thus configured to accommodate screws. The bottom connection openings 612a, 619a are in the assembled state aligned with bottom tracks 61a1, 61a2 provided in the bottom element 61a. When assembling the top casing 61 screws (not shown) are inserted through the bottom connection openings 612a, 619a and into the bottom tracks 61a1, 61a2, thus connecting the bottom end element 611a to the bottom element 61a.

**[0049]** Furthermore, the bottom end element 611a comprises a bottom flange receiving element 618a. The bottom flange receiving element 618a is configured to receive a top flange 61b2 formed by the top element 61b. When assembling the top casing 61 the top flange 61b2 is hooked into the bottom flange receiving element 618a, thus connecting the bottom end element 611a with the top element 61b.

**[0050]** Correspondingly, the top end element 611b comprises at least one connector for connecting the top end element 611b to the top element 61b. The connector may be for providing a screw or snap connection between the bottom end element 611a and the bottom element 61a.

**[0051]** In the shown embodiment, the top end element 611b comprises a connector in the form of one top connection opening 612b for facilitating a screw connection between the top end element 611b and the top element 61b. In the shown embodiment, the top connection opening 612b is configured to accommodate a screw. The top connection opening 612b is in the assembled state aligned with a top track 61b1 formed by the top element 61b. When assembling the top casing 61 a screw is inserted through the top connection opening 612b and into the top track 61b1, thus connecting the top end element 611b to the top element 61b.

**[0052]** In the assembled state the bottom end element 611a and the top end element 611b defines an engagement through-hole 612. The engagement through-hole 612 extends from the reel space 61w to the bar space 61p. The engagement through-hole 612 allows the engagement means 672 of the winding reel 671 to extend from the reel space 61w and into the roller bar 61r arranged in the bar space 61p.

**[0053]** Furthermore, the top element 61b of the top casing 61 is seen to be provided with flange 71 forming part of the suspension device 70 for mounting the screen-

ing arrangement to the roof window 1.

**[0054]** Referring to Fig. 8 showing a partially exploded perspective schematic view of a right-hand side of the top casing 61 with the roller bar 61r according to an embodiment of the invention.

**[0055]** The top end element 611b is seen in an exploded state away from the rest of the top casing 61. The top end element 611b comprises a plurality of connectors for connecting the top end element 611b to the bottom end element 611a. The connectors may be for providing a screw or snap connection between the top end element 611b and the bottom end element 611a.

**[0056]** In the shown embodiment, these connectors are formed as follows: One of the top connectors is formed as a top connection opening 614b for facilitating a screw between the top end element 611b and the bottom end element 611a. The bottom end element 611a comprises a corresponding bottom connection opening 614a. When connecting the top end element 611b to the bottom end element 611a, the top connection opening 614b is aligned with the corresponding bottom connection opening 614a and a screw may be inserted through the openings 614a, 614b, thus connecting the bottom end element 611a to the top end element 611b.

**[0057]** In some embodiments a screw may be inserted through the end cover 613R, 613L and through the corresponding connection openings 614a, 614b of the bottom end element 611a and the top end element 611b to connect the end cover 613R, 613L to the bottom end element 611a and the top end element 611b.

**[0058]** In the embodiment shown, the top end element 611b comprises a top dome 613b with a central bore extending through it. The bottom end element 611a comprises a bottom dome 613a with a central bore extending through it. During assembly the top dome 613b is received within the bottom dome 613a. The top dome 613b is received rotatably within the bottom dome 613a, thus forming a pivot connection between the top end element 611b and the bottom end element 611a. The pivot connection allows the top end element 611b to rotate between an open state, cf. Figs 9 and 10, and a closed state, cf. Fig 6. Furthermore, a screw may be inserted through the central bores of the top dome 613b and the bottom dome 613a to further connect the domes 613a, 613b together.

**[0059]** In some embodiments a screw may be inserted through the end cover 613R, 613L and through the domes 613a, 613b of the bottom end element 611a and the top end element 611b to connect the end cover 613R, 613L to the bottom end element 611a and the top end element 611b.

**[0060]** As will be described in more detail in the following, the bottom end element 611a and the top end element 611b further comprises a plurality of connection openings for connecting the end cover 613R, 613L to the bottom end element 611a and the top end element 611b. One or more screws may be inserted through openings in the end cover 613R, 613L and into connection openings

of the bottom end element 611a and the top end element 611b to connect the end cover 613R, 613L with the bottom end element 611a and the top end element 611b.

**[0061]** Referring to Figs 9 and 10 showing different perspective schematic views of a bottom end element 611a and a top end element 611b, where the end element 611b is in an open state, according to an embodiment of the invention.

**[0062]** The bottom end element 611a and the top end element 611b comprises one or more first support surfaces 615a, 616a, 615b, 616b. In the shown embodiment, the bottom end element 611a comprises a minor support surface 615a and a major support surface 616a. The minor support surface 615a and the major support surface 616a each extends from a perimeter of the engagement through-hole 612 defined by the top end element 611b and the bottom end element 611a in the assembled state. The major support surface 616a extends from larger part of the perimeter relative to the minor support surface 615a. Preferably, the major support surface 616a is arranged to receive a resulting force from the winding reel 671 caused by movement of the screening body 65.

**[0063]** In the shown embodiment, the top end element 611b comprises two minor support surfaces 615b, 616b. The minor support surfaces 615b, 616b of the top end element extends from a perimeter of the engagement through-hole 612.

**[0064]** The support surfaces 615a, 616a, 615b, 616b are adapted for supporting the winding reel 671 and facilitating rotation of the winding reel 671 in a winding direction and an unwinding direction.

**[0065]** The bottom end element further 611a comprises a cord passage 610. The cord passage 610 allows the cord 67 (not shown in this figure) to pass from the side rail 63 and into the reel space 61w.

**[0066]** The bottom end element further comprises a winding support 617a. The winding support 617a is adapted for supporting the winding reel 671 and for guiding the cord 67 connected to the winding reel 671 towards the cord passage 610.

**[0067]** Referring to Figs 11 and 12 showing different perspective schematic views of an end cover 613R according to an embodiment of the invention. The end cover 613R is configured to form the right-hand end cover in the assembled screening device 60 in the embodiment shown, and comprises a plurality of connectors in the form of cover connection openings 614, 615, 616, 617 for connecting the end cover 613R to the bottom end element 611a and the top end element 611b. The connectors 614, 615, 616, 617 may be for providing a screw or snap connection between the end cover 613 and the bottom end element 611a and the top end element 611b. In the shown embodiment, the end cover 613 comprises four cover connection openings 614, 615, 616, 617 for facilitating a screw connection between the end cover 613 and the bottom end element 611a and the top end element 611b. The cover connection openings 614, 615,

616, 617 are in the assembled state aligned with bottom connection openings 612a, 613a in the bottom end element 611a and top connection openings 612b, 613b in the top end element 611b. When assembling the top casing 61 screws are inserted through the end cover openings 614, 615, 616, 617 and into the aligned bottom connection openings 612a, 613a and top connection openings 612b, 613b, thus connecting the end cover 613 to the bottom end element 611a and the end element 611b.

**[0068]** Furthermore, the end cover 613 comprises one or more second support surfaces 613s. In the shown embodiment, the end cover 613 comprises four second support surfaces 613s. The second support surfaces 613s extends perpendicularly from a side of the end cover facing the reel space 61w. The relative placement of the second support surfaces 613s substantially corresponds to that of the first support surfaces 615a, 616a, 615b, 616b. The sizes of the second support surfaces 613s substantially correspond to those of the first support surfaces 615a, 616a, 615b, 616b. The positioning of the second support surfaces 613s substantially corresponds to a linear displacement of the first support surfaces 615a, 616a, 615b, 616b, along a direction parallel to the longitudinal extension of the roller bar 61r.

**[0069]** Referring to Figs 13a and 13b showing different perspective schematic views of an end cover according to another embodiment of the invention. Elements having the same or analogous function as in the embodiment of Figs 11 and 12 are denoted by the same reference numerals. Only differences will be described in detail. The end cover 613L shown in Figs 13a and 13b is configured to form the left-hand end cover in the embodiment shown.

**[0070]** The features of the end cover 613L depicted in Figs 13a and 13b substantially correspond to the features of the end cover 613R depicted in Figs 11 and 12. However, the depicted end cover 613L further comprises a through-hole 618. The through-hole 618 extends through the end cover 613 and provides a passage through the end cover 613. The through-hole 618 is aligned with the engagement through-hole 612. The through-hole 618 allows drive means to be inserted through the end cover 613 and the engagement through-hole 612 into the roller bar 61r.

**[0071]** Details of an embodiment of a screening arrangement including drive means in the form of a motor unit 68 is shown in Fig. 14, in which the left-hand end cover 613 shown in Figs 13a and 13b is shown together with winding reel 671 together with the motor unit 68. It is noted that details of the top casing 61 itself are not shown, including bottom and top elements etc. Once the screening arrangement 50 has been mounted on the roof window 1, it is possible to provide pairing of the motor control means of the motor unit 68 with for instance a remote control unit (not shown). Once this has been carried out, access to the interior of the top casing 61 is closed off by a flap 613f (shown in Fig. 17).

**[0072]** Referring to Figs 15a to 15f showing perspective schematic views of the right-hand corner of a top casing at different stages of assembly. While the steps are shown referring to details of the top casing 61 of the embodiments of the screening arrangement 50 described in the above, such steps are also applicable to elements that have been modified within the framework of the appended claims.

**[0073]** In Fig. 15a a bottom element 61a and a roller bar 61r is provided. The roller bar 61r is received by the bottom element 61a and supported by the bottom element 61a.

**[0074]** In Fig. 15b a bottom end element 611a has been provided. The bottom end element 611a is connected to the bottom element 61a via a snap connection or a screw connection. The end element 611a comprises bottom connection openings 612a, 619a, and the end element 61a comprises bottom tracks 61a1, 61a2. The bottom end element 611a is connected to the bottom element 61a by inserting screws through the connection openings 612a, 619a, and into the bottom tracks 61a1, 61a2.

**[0075]** In Fig. 15c a top end element 611b has been provided. The top end element 611b comprises a top dome 613b and the bottom end element 611a comprises a bottom dome 613a. The end element 611b is connected to the bottom end element 611a, by inserting the top dome 613b, of the top end element 611b into the bottom dome 613a of the bottom end element 611a. The domes 613a, 613b pivotally connects the top end element 611b to the bottom end element 611a.

**[0076]** In Fig. 15d a winding reel 671 has been provided. The winding reel 671 comprises engagement means 672. The winding reel 671 is connected to the roller bar 61 by inserting the engagement means 672 of the winding reel 671 through an engagement hole 612 formed by the top end element 611b and the bottom end element 611a.

**[0077]** In Fig. 15e a top element 61a has been provided. The top element 61a is connected to the bottom end element 611a and the top end element 611b. The top element 61a is connected to the bottom end element 611a by hooking a top flange 61b2 of the top element onto a bottom flange receiving element 618a of bottom end element 611b. The top element 61a is connected to the top end element 611a by inserting a screw through a top connection opening 612b in the top end element 611b and into a top track 61b1 of the top element 61b.

**[0078]** In Fig. 15f an end cover 613R has been provided. The end cover 613R is connected to the bottom end element 611a and the top end element 611b. The end cover 613R is connected by aligning one or more cover openings 614, 615, 616, 617 with bottom connection openings 612a, 613a in the bottom end element 611a and top connection openings 612b, 613b in the top end element 611b. After aligning of the end cover 613R, screws are inserted through the end cover openings 614, 615, 616, 617 and into the aligned bottom connection openings 612a, 613a and top connection openings

612b, 613b, thus connecting the end cover 613R to the bottom end element 611a and the end element 611b.

**[0079]** Connection of the second longitudinal end 61r2 of the roller bar 61r and the opposite winding reel 671 to the top casing 61 is carried out in substantially the same manner. In case an end cover is provided at that end, such end cover may take the form of left-hand end cover 613L to which a motor unit 68 is connected.

**[0080]** Finally, Fig. 17 shows the upper left-hand corner of the screening device 60 of an embodiment of the screening arrangement 50 according to the invention in a mounted condition. It is noted that a subjacent roof window or skylight is not shown, just as the corner cover element (82) has been removed, and the solar panel 61s is shown in an exploded view. The solar panel 61s is formed by a solar panel frame 61s1 which is positioned on top of a solar panel element 61s2 to overlap the solar panel element 61s2 in the mounted condition. A solar panel arm 61s3 is provided to position the solar panel 61s correctly relative to the top casing 61. The solar panel arm 61s3 has the additional function of acting as a guide for a solar panel cable 61s4 extending from the solar panel element 61s2 (or non-shown circuitry connected thereto) and the drive means of the screening device 60. At the end opposite the solar panel arm 61s3, the solar panel frame 61s1 is kept in abutment with the top casing 61 by means of an adhesive pad 61s5. Further elements shown include solar panel labels 61s6, and the flap 613f of the end cover 613L.

**[0081]** Specific embodiments of the invention have now been described. However, several alternatives are possible, as would be apparent for someone skilled in the art.

**[0082]** Although, a specific assembly order has been disclosed in relation Figs 15a to 15f the invention is not limited to this order. For example, in some embodiments the top end element 611b is connected to the bottom end element 611a, and then the assembled bottom end element 611a and the top end element 611b is connected to the top element 61b and the bottom element 61a. In another embodiment the winding reel 671 is connected to the roller bar 61r after the top element 61b has been connected to the bottom end element 611a and the top end element 611b.

**[0083]** Such and other obvious modifications must be considered to be within the scope of the present invention, as it is defined by the appended claims.

#### List of reference numerals

##### [0084]

- 1 roof window
- 1a window opening
- 2 roof
- 2a roof opening
- 3 weather shield
- 4 window portion

- 5 insulating glazing unit, IGU
- 6 sash
- 7 frame
- 8 weather shield pane
- 9 weather shield skirt
- 10 frame member
- 11 first sash member
- 12 second sash member
- 14 fourth sash member
- 50 screening arrangement
- 60 screening device

- 61 top casing
- 61a bottom element
- 61a1 bottom track
- 61a2 bottom track
- 611a bottom end element
- 612a bottom connection opening
- 613a bottom dome
- 614a bottom connection opening
- 615a first bottom support surface
- 616a second bottom support surface
- 617a winding support
- 618a bottom flange receiving element
- 619a bottom connection opening
- 61b top element
- 61b1 top track
- 61b2 top flange
- 61p bar space
- 61r roller bar
- 61r1 first longitudinal end
- 61r2 second longitudinal end
- 61r3 roller bar connector
- 61s solar panel
- 61s1 solar panel frame
- 61s2 solar panel element
- 61s3 solar panel arm
- 61s4 solar panel cable
- 61s5 solar panel adhesive pad
- 61s6 solar panel labels
- 61w reel space
- 611b top end element
- 612b top connection opening
- 613b top dome
- 614b top connection opening
- 615b first top support surface
- 616b second top support surface
- 610 cord passage
- 612 engagement through-hole
- 613R end cover
- 613L end cover
- 613f flap
- 613s cover support surface
- 614 cover connection opening
- 615 cover connection opening
- 616 cover connection opening
- 617 cover connection opening
- 618 through-hole

62 bottom profile	
63 side rail	
64 side rail	
65 screening body	
66 bottom bar	5
67 cord system	
67c cord	
671 winding reel	
672 engagement means/snap-legs	
673 first winding flange	10
674 second winding flange	
675 winding track	
68 drive means/motor unit	
70 suspension device	15
71 top flange	
72 bottom flange	
74 side flange	20
80 corner cover assembly	
81 corner cover element (upper right-hand)	
82 corner cover element (upper left-hand)	
83 corner cover element (lower right-hand)	
84 corner cover element (lower left-hand)	25
LC1 line of contact	
LC2 line of contact	
LC4 line of contact	30

## Claims

1. A screening arrangement (50) for a roof window (1) to be installed in an inclined or flat roof (2) of a building to cover an opening (1a) of the window (1) in a mounted condition of the screening arrangement (50), where the screening arrangement (50), where the screening arrangement (50) comprises:

a screening device (60) including a top casing (61), a screening body (65) having two side edges, a first end portion and a second end portion, said screening body (65) being movable in a longitudinal direction between a non-screening position, in which the screening body (65) is substantially accommodated in the top casing (61), and a number of screening positions in which the screening body (65) is deployed from the top casing (61) and covers the opening partially or entirely, two side rails (63, 64) configured to extend substantially perpendicularly to the top casing (61) in a mounted condition of the screening arrangement (50), the top casing (61) and the two side rails (63, 64) defining an outer perimeter of the screening device (60), and a roller bar (61r) accommodated in the top casing (61) and connected to drive means, the drive means being configured

to rotate the roller bar (61r) in a winding direction and an unwinding direction, the first end portion of the screening body (65) being connected to the roller bar (61r) such that the screening body (65) is wound on the roller bar (61r) in the non-screening position, and wherein the roller bar (61r) extends longitudinally between a first longitudinal end (61r1) and a second longitudinal end (61r2), the top casing (61) comprising a bottom element (61a) and a top element (61b) delimiting a bar space (61p) accommodating and limiting movement of the roller bar (61r),

### characterised in that

the screening arrangement (50) comprises a winding device comprising at least one winding reel (671) in connection with or connectable to the roller bar (61r) at the first longitudinal end (61r1) of the roller bar (61r), that the top casing (61) comprises a bottom end element (611a) and a top end element (611b) adjacent to the first longitudinal end (61r1) of the roller bar (61r) and further delimiting the bar space (61p), the bottom end element (611a) and the top end element (611b) delimiting a reel space (61w) accommodating and limiting movement of the at least one winding reel (671), and that the bottom element (61a) of the top casing (61) is configured to receive and support the roller bar (61r) during assembly of the screening arrangement (50) and the top element (61b) is configured to be connected to the bottom element (61a) subsequent to the bottom element (61a) receiving the roller bar (61r).

2. A screening arrangement (50) according to claim 1, wherein the at least one winding reel (671) comprises engagement means (672) adapted for connecting the at least one winding reel to the roller bar (61r), wherein the bottom end element (611a) and the top end element (611b) are configured to form an engagement through-hole (612) extending from the reel space (61w) to the bar space (61p), and wherein the engagement means (672) extends through the engagement through-hole (612) and into the roller bar (61r).
3. A screening arrangement (50) according to claim 2, wherein the engagement means are formed as one or more snap-legs (672) engaged in a snap-connection with one or more corresponding connectors (61r3) in the roller bar (61r).
4. A screening arrangement (50) according to any of the preceding claims, wherein the top casing (61) comprises an end cover (613) further delimiting the reel space (61w).
5. A screening arrangement (50) according to claim 4

- when dependent on claim 2 or 3, wherein the end cover (613) comprises a through-hole (618) formed in the end cover (613) and aligned with the engagement through-hole (612) formed by the bottom end element (611a) and the top end element (611b) to allow drive means to be inserted through the through-hole (618), the engagement through-hole (612) and into the roller bar (61r).
6. A screening arrangement (50) according to any of claims 4 or 5, wherein the end cover (613) comprises one or more second support surfaces (616) supporting the winding reel (671) and facilitating rotation of the winding reel (671) in the winding direction and the unwinding direction.
7. A screening arrangement (50) according to any of the preceding claims, wherein the bottom end element (611a) and/or the top end element (611b) comprises one or more first support surfaces (615) supporting the winding reel (671) and facilitating rotation of the winding reel (671) in the winding direction and the unwinding direction.
8. A screening arrangement (50) according to any of the preceding claims, wherein the bottom end element (611a) is connected to the bottom element (61a) and the top end element (611b), wherein the top end element (611b) is connected to the top element (61b), and wherein the bottom element (61a) is connected to the top element (61b) via the bottom end element (611b) and the top end element (611a).
9. A screening arrangement (50) according to any of the preceding claims, wherein the bottom end element (611a) comprises a plurality of connectors for connecting the bottom end element (611a) to the bottom element (61a), the connectors preferably being configured for providing a screw or snap connection between the bottom end element and the bottom element.
10. A screening arrangement (50) according to any of the preceding claims, wherein the top end element (611b) comprises at least one connector for connecting the top end element (611b) to the top element (61b), the connector(s) preferably being for providing a screw or snap connection between the bottom end element (611a) and the bottom element (61a).
11. A screening arrangement (50) according to any of the preceding claims, wherein the bottom end element (611a) is connected to the top end element (611b) by a set of connectors, preferably including a first, pivotal connection (613a, 613b), more preferably also in a second, releasable connection (614a, 614b).
12. A screening arrangement according to any of the preceding claims, wherein the winding device forms part of a cord system (67) comprising a set of cords (67c), the at least one winding reel (671), and optionally return elements and/or tightening means for the cords.
13. A screening arrangement (50) according to any of the preceding, wherein the screening arrangement (50) is adapted for a skylight or roof window.
14. A method for assembling a top casing (61) with a roller bar (61r) for a screening arrangement (50), comprising the steps of:
- providing a bottom element (61a), a top element (61b) and a roller bar (61r),  
 providing a bottom end element (611a) and a top end element (611b),  
 supporting the roller bar (61r) on the bottom element (61a),  
 fixedly connecting the bottom end element (611a) to the bottom element (61a),  
 pivotally connecting the bottom end element (611a) to the top end element (611b), wherein the top end element (611a) is pivotal between an open state and a closed state,  
 fixedly connecting, when the top end element (611b) is in the closed state, the top end element (611b) to the top element (61b), and thereby enclosing the roller bar (61r) by connecting the top element (61b) to the bottom element (61a), wherein a bar space (61p) is formed in-between the bottom element (61a) and the top element (61b), such that the bar space (61p) accommodates and limits movement of the roller bar (61r).
15. A method for assembling a top casing (61) for a screening arrangement (50) according to claim 14, comprising the additional steps of:
- providing at least one winding reel (671),  
 positioning the winding reel in a reel space (71w) formed by the bottom end element (611a) and the top end element (611b), and  
 connecting the at least one winding reel to a longitudinal end of the roller bar.

## 50 Patentansprüche

1. Abschirmungsanordnung (50) für ein Dachfenster (1) zur Installation in einem geneigten oder flachen Dach (2) eines Gebäudes zum Abdecken einer Öffnung (1a) des Fensters (1) in einem eingebauten Zustand der Abschirmungsanordnung (50), wobei die Abschirmungsanordnung (50) Folgendes umfasst:

eine Abschirmungsvorrichtung (60), umfassend ein oberes Gehäuse (61), einen Abschirmungskörper (65) mit zwei Seitenkanten, einem ersten Endteil und einem zweiten Endteil, wobei der Abschirmungskörper (65) in einer Längsrichtung zwischen einer nicht abschirmenden Position, in der der Abschirmungskörper (65) im Wesentlichen in dem oberen Gehäuse (61) aufgenommen ist, und einer Anzahl von abschirmenden Positionen, in denen der Abschirmungskörper (65) aus dem oberen Gehäuse (61) ausgezogen ist und die Öffnung teilweise oder vollständig abdeckt, beweglich ist, zwei Seitenschienen (63, 64), die so ausgestaltet sind, dass sie sich in einem eingebauten Zustand der Abschirmungsanordnung (50) im Wesentlichen senkrecht zu dem oberen Gehäuse (61) erstrecken, wobei das obere Gehäuse (61) und die zwei Seitenschienen (63, 64) einen Außenumfang der Abschirmungsvorrichtung (60) definieren, und eine Rollenstange (61r), die in dem oberen Gehäuse (61) aufgenommen und mit Antriebsmitteln verbunden ist, wobei die Antriebsmittel dazu ausgestaltet sind, die Rollenstange (61r) in einer Aufwickelrichtung und einer Abwickelrichtung zu drehen, wobei der erste Endabschnitt des Abschirmungskörpers (65) mit der Rollenstange (61r) derart verbunden ist, dass der Abschirmungskörper (65) in der nicht abschirmenden Position auf die Rollenstange (61r) aufgewickelt wird, und wobei sich die Rollenstange (61r) in Längsrichtung zwischen einem ersten Längsende (61r1) und einem zweiten Längsende (61r2) erstreckt, wobei das obere Gehäuse (61) ein unteres Element (61a) und ein oberes Element (61b) umfasst, die einen Stangenraum (61p) begrenzen, der eine Bewegung der Rollenstange (61r) aufnimmt und begrenzt,

**dadurch gekennzeichnet, dass**

die Abschirmungsanordnung (50) eine Wickelvorrichtung umfasst, die mindestens eine Wickelspule (671) umfasst, die an dem ersten Längsende (61r1) der Rollenstange (61r) mit der Rollenstange (61r) in Verbindung steht oder verbindbar ist, dass das obere Gehäuse (61) ein unteres Endelement (611a) und ein oberes Endelement (611b) umfasst, die an das erste Längsende (61r1) der Rollenstange (61r) angrenzen und den Stangenraum (61p) weiter begrenzen, wobei das untere Endelement (611a) und das obere Endelement (611b) einen Spulenraum (61w) begrenzen, der eine Bewegung der mindestens einen Wickelspule (671) aufnimmt und begrenzt, und dass das untere Element (61a) des oberen Gehäuses (61) dazu ausgestaltet ist, die Rollenstange (61r) während eines Zusammenbaus der Abschirmungsanordnung

(50) zu empfangen und zu stützen, und das obere Element (61b) dazu ausgestaltet ist, mit dem unteren Element (61a) verbunden zu werden, nachdem das untere Element (61a) die Rollenstange (61r) empfängt.

2. Abschirmungsanordnung (50) nach Anspruch 1, wobei die mindestens eine Wickelspule (671) Eingriffsmittel (672) umfasst, die zum Verbinden der mindestens einen Wickelspule mit der Rollenstange (61r) ausgelegt sind, wobei das untere Endelement (611a) und das obere Endelement (611b) dazu ausgestaltet sind, ein Eingriffsdurchgangsloch (612) zu bilden, das sich von dem Spulenraum (61w) zu dem Stangenraum (61p) erstreckt, und wobei sich die Eingriffsmittel (672) durch das Eingriffsdurchgangsloch (612) und in die Rollenstange (61r) erstrecken.
3. Abschirmungsanordnung (50) nach Anspruch 2, wobei die Eingriffsmittel als ein oder mehrere Schnappschenkel (672) ausgebildet sind, die in einer Schnappverbindung mit einem oder mehreren entsprechenden Verbindern (61r3) in der Rollenstange (61r) in Eingriff gebracht werden.
4. Abschirmungsanordnung (50) nach einem der vorhergehenden Ansprüche, wobei das obere Gehäuse (61) eine Endabdeckung (613) umfasst, die den Spulenraum (61w) weiter begrenzt.
5. Abschirmungsanordnung (50) nach Anspruch 4, wenn abhängig von Anspruch 2 oder 3, wobei die Endabdeckung (613) ein Durchgangsloch (618) umfasst, das in der Endabdeckung (613) ausgebildet und mit dem durch das untere Endelement (611a) und das obere Endelement (611b) gebildeten Eingriffsdurchgangsloch (612) ausgerichtet ist, um zu ermöglichen, dass Antriebsmittel durch das Durchgangsloch (618), das Eingriffsdurchgangsloch (612) und in die Rollenstange (61r) eingeführt werden.
6. Abschirmungsanordnung (50) nach einem der Ansprüche 4 oder 5, wobei die Endabdeckung (613) eine oder mehrere zweite Stützflächen (616) umfasst, die die Wickelspule (671) stützen und eine Drehung der Wickelspule (671) in der Aufwickelrichtung und der Abwickelrichtung erleichtern.
7. Abschirmungsanordnung (50) nach einem der vorhergehenden Ansprüche, wobei das untere Endelement (611a) und/oder das obere Endelement (611b) eine oder mehrere erste Stützflächen (615) umfassen, die die Wickelspule (671) stützen und eine Drehung der Wickelspule (671) in der Aufwickelrichtung und der Abwickelrichtung erleichtern.
8. Abschirmungsanordnung (50) nach einem der vorhergehenden Ansprüche, wobei das untere Ende-

- ment (611a) mit dem unteren Element (61a) und dem oberen Endelement (611b) verbunden ist, wobei das obere Endelement (611b) mit dem oberen Element (61b) verbunden ist, und wobei das untere Element (61a) über das untere Endelement (611b) und das obere Endelement (611a) mit dem oberen Element (61b) verbunden ist.
- 5
9. Abschirmungsanordnung (50) nach einem der vorhergehenden Ansprüche, wobei das untere Endelement (611a) mehrere Verbinder zum Verbinden des unteren Endelements (611a) mit dem unteren Element (61a) umfasst, wobei die Verbinder vorzugsweise zum Bereitstellen einer Schraub- oder Schnappverbindung zwischen dem unteren Endelement und dem unteren Element ausgestaltet sind.
- 10
10. Abschirmungsanordnung (50) nach einem der vorhergehenden Ansprüche, wobei das obere Endelement (611b) mindestens einen Verbinder zum Verbinden des oberen Endelements (611b) mit dem oberen Element (61b) umfasst, wobei der (oder die) Verbinder vorzugsweise zum Bereitstellen einer Schraub- oder Schnappverbindung zwischen dem unteren Endelement (611a) und dem unteren Element (61a) dienen.
- 15
11. Abschirmungsanordnung (50) nach einem der vorhergehenden Ansprüche, wobei das untere Endelement (611a) mit dem oberen Endelement (611b) durch einen Satz von Verbindern verbunden ist, die vorzugsweise eine erste, schwenkbare Verbindung (613a, 613b), stärker bevorzugt auch eine zweite, lösbare Verbindung (614a, 614b) beinhalten.
- 20
12. Abschirmungsanordnung nach einem der vorhergehenden Ansprüche, wobei die Wickelvorrichtung einen Teil eines Schnursystems (67) bildet, das einen Satz von Schnüren (67c), die mindestens eine Wickelspule (671) und optional Rückstellelemente und/oder Spannmittel für die Schnüre umfasst.
- 25
13. Abschirmungsanordnung (50) nach einem der vorhergehenden Ansprüche, wobei die Abschirmungsanordnung (50) für ein Oberlicht oder Dachfenster ausgelegt ist.
- 30
14. Verfahren zum Zusammenbauen eines oberen Gehäuses (61) mit einer Rollenstange (61r) für eine Abschirmungsanordnung (50), umfassend die folgenden Schritte:
- 35
- Bereitstellen eines unteren Elements (61a), eines oberen Elements (61b) und einer Rollenstange (61r),
- 40
- Bereitstellen eines unteren Endelements (611a) und eines oberen Endelements (611b),
- 45
- Abstützen der Rollenstange (61r) an dem unteren Element (61a),
- festes Verbinden des unteren Endelements (611a) mit dem unteren Element (61a),
- schwenkbares Verbinden des unteren Endelements (611a) mit dem oberen Endelement (611b), wobei das obere Endelement (611a) zwischen einem geöffneten Zustand und einem geschlossenen Zustand schwenkbar ist,
- festes Verbinden, wenn sich das obere Endelement (611b) im geschlossenen Zustand befindet, des oberen Endelements (611b) mit dem oberen Element (61b), und dadurch
- Einschließen der Rollenstange (61r) durch Verbinden des oberen Elements (61b) mit dem unteren Element (61a), wobei zwischen dem unteren Element (61a) und dem oberen Element (61b) ein Stangenraum (61p) gebildet wird, so dass der Stangenraum (61p) eine Bewegung der Rollenstange (61r) aufnimmt und begrenzt.
- 50
15. Verfahren zum Zusammenbauen eines oberen Gehäuses (61) für eine Abschirmungsanordnung (50) nach Anspruch 14, umfassend die folgenden zusätzlichen Schritte:
- Bereitstellen mindestens einer Wickelspule (671),
- Positionieren der Wickelspule in einem Spulenraum (71w), der durch das untere Endelement (611a) und das obere Endelement (611b) gebildet wird, und
- Verbinden der mindestens einen Wickelspule mit einem Längsende der Rollenstange.
- 55

## Revendications

1. Agencement d'écran (50) pour une fenêtre de toit (1) destinée à être installée dans un toit incliné ou plat (2) d'un bâtiment pour couvrir une ouverture (1a) de la fenêtre (1) dans un état monté de l'agencement d'écran (50), où l'agencement d'écran (50) comprend :

un dispositif d'écran (60) incluant un boîtier supérieur (61), un corps d'écran (65) ayant deux bords latéraux, une première portion d'extrémité et une deuxième portion d'extrémité, ledit corps d'écran (65) pouvant être déplacé dans une direction longitudinale entre une position de non-écran, dans laquelle le corps d'écran (65) est substantiellement logé dans le boîtier supérieur (61), et un certain nombre de positions d'écran dans lesquelles le corps d'écran (65) est déployé à partir du boîtier supérieur (61) et couvre l'ouverture partiellement ou entièrement, deux rails latéraux (63, 64) configurés pour s'é-

tendre de manière substantiellement perpendiculaire au boîtier supérieur (61) dans un état monté de l'agencement d'écran (50), le boîtier supérieur (61) et les deux rails latéraux (63, 64) définissant un périmètre externe du dispositif d'écran (60), et une barre de rouleau (61r) logée dans le boîtier supérieur (61) et raccordée à un moyen d'entraînement, le moyen d'entraînement étant configuré pour faire entrer en rotation la barre de rouleau (61r) dans une direction d'enroulement et une direction de déroulement, la première portion d'extrémité du corps d'écran (65) étant raccordée à la barre de rouleau (61r) de telle sorte que le corps d'écran (65) soit enroulé sur la barre de rouleau (61r) dans la position de non-écran, et la barre de rouleau (61r) s'étendant longitudinalement entre une première extrémité longitudinale (61r1) et une deuxième extrémité longitudinale (61r2), le boîtier supérieur (61) comprenant un élément inférieur (61a) et un élément supérieur (61b) délimitant un espace de barre (61p) logeant, et limitant un déplacement de, la barre de rouleau (61r),

**caractérisé en ce que**

l'agencement d'écran (50) comprend un dispositif d'enroulement comprenant au moins une bobine d'enroulement (671) en raccordement avec ou pouvant être raccordée à la barre de rouleau (61r) au niveau de la première extrémité longitudinale (61r1) de la barre de rouleau (61r), que le boîtier supérieur (61) comprend un élément d'extrémité inférieure (611a) et un élément d'extrémité supérieure (611b) adjacent à la première extrémité longitudinale (61r1) de la barre de rouleau (61r) et délimitant plus avant l'espace de barre (61p), l'élément d'extrémité inférieure (611a) et l'élément d'extrémité supérieure (611b) délimitant un espace de bobine (61w) logeant, et limitant le déplacement de, l'au moins une bobine d'enroulement (671), et que l'élément inférieur (61a) du boîtier supérieur (61) est configuré pour recevoir et supporter la barre de rouleau (61r) pendant l'assemblage de l'agencement d'écran (50) et l'élément supérieur (61b) est configuré pour être raccordé à l'élément inférieur (61a) suite à la réception de la barre de rouleau (61r) par l'élément inférieur (61a) .

2. Agencement d'écran (50) selon la revendication 1, dans lequel l'au moins une bobine d'enroulement (671) comprend un moyen de mise en prise (672) conçu pour raccorder l'au moins une bobine d'enroulement à la barre de rouleau (61r), dans lequel l'élément d'extrémité inférieure (611a) et l'élément d'extrémité supérieure (611b) sont configurés pour former un trou traversant de mise en prise (612)

s'étendant de l'espace de bobine (61w) à l'espace de barre (61p), et le moyen de mise en prise (672) s'étendant à travers le trou traversant de mise en prise (612) et jusque dans la barre de rouleau (61r) .

3. Agencement d'écran (50) selon la revendication 2, dans lequel le moyen de mise en prise est formé comme une ou plusieurs pattes d'encliquetage (672) mises en prise dans un raccordement par encliquetage avec un ou plusieurs dispositifs de raccordement (61r3) correspondants dans la barre de rouleau (61r).
4. Agencement d'écran (50) selon l'une quelconque des revendications précédentes, dans lequel le boîtier supérieur (61) comprend un couvercle d'extrémité (613) délimitant plus avant l'espace de bobine (61w).
5. Agencement d'écran (50) selon la revendication 4 lorsqu'elle dépend de la revendication 2 ou de la revendication 3, dans lequel le couvercle d'extrémité (613) comprend un trou traversant (618) formé dans le couvercle d'extrémité (613) et aligné avec le trou traversant de mise en prise (612) formé par l'élément d'extrémité inférieure (611a) et l'élément d'extrémité supérieure (611b) pour permettre à un moyen d'entraînement d'être inséré à travers le trou traversant (618), le trou traversant de mise en prise (612) et jusque dans la barre de rouleau (61r).
6. Agencement d'écran (50) selon l'une quelconque des revendications 4 ou 5, dans lequel le couvercle d'extrémité (613) comprend une ou plusieurs deuxièmes surfaces de support (616) supportant la bobine d'enroulement (671) et facilitant une rotation de la bobine d'enroulement (671) dans la direction d'enroulement et la direction de déroulement.
7. Agencement d'écran (50) selon l'une quelconque des revendications précédentes, dans lequel l'élément d'extrémité inférieure (611a) et/ou l'élément d'extrémité supérieure (611b) comprend une ou plusieurs premières surfaces de support (615) supportant la bobine d'enroulement (671) et facilitant une rotation de la bobine d'enroulement (671) dans la direction d'enroulement et la direction de déroulement.
8. Agencement d'écran (50) selon l'une quelconque des revendications précédentes, dans lequel l'élément d'extrémité inférieure (611a) est raccordé à l'élément inférieur (61a) et à l'élément d'extrémité supérieure (611b), l'élément d'extrémité supérieure (611b) étant raccordé à l'élément supérieur (61b), et l'élément inférieur (61a) étant raccordé à l'élément supérieur (61b) par l'intermédiaire de l'élément d'extrémité inférieure (611b) et de l'élément d'extrémité

- supérieure (611a).
- 9.** Agencement d'écran (50) selon l'une quelconque des revendications précédentes, dans lequel l'élément d'extrémité inférieure (611a) comprend une pluralité de dispositifs de raccordement pour raccorder l'élément d'extrémité inférieure (611a) à l'élément inférieur (61a), les dispositifs de raccordement étant préférablement configurés pour fournir un raccordement par vis ou encliquetage entre l'élément d'extrémité inférieure et l'élément inférieur. 5 10
- 10.** Agencement d'écran (50) selon l'une quelconque des revendications précédentes, dans lequel l'élément d'extrémité supérieure (611b) comprend au moins un dispositif de raccordement pour raccorder l'élément d'extrémité supérieure (611b) à l'élément supérieur (61b), le(s) dispositif(s) de raccordement étant préférablement destiné(s) à fournir un raccordement par vis ou encliquetage entre l'élément d'extrémité inférieure (611a) et l'élément inférieur (61a). 15 20
- 11.** Agencement d'écran (50) selon l'une quelconque des revendications précédentes, dans lequel l'élément d'extrémité inférieure (611a) est raccordé à l'élément d'extrémité supérieure (611b) par un ensemble de dispositifs de raccordement, incluant préférablement un premier raccordement pivotant (613a, 613b), plus préférablement également un deuxième raccordement libérable (614a, 614b). 25 30
- 12.** Agencement d'écran selon l'une quelconque des revendications précédentes, dans lequel le dispositif d'enroulement fait partie d'un système de cordons (67) comprenant un ensemble de cordons (67c), l'au moins une bobine d'enroulement (671), et facultativement des éléments de retour et/ou un moyen de serrage pour les cordons. 35
- 13.** Agencement d'écran (50) selon l'une quelconque des revendications précédentes, l'agencement d'écran (50) étant conçu pour une fenêtre de plafond ou de toit. 40
- 14.** Procédé d'assemblage d'un boîtier supérieur (61) avec une barre de rouleau (61r) pour un agencement d'écran (50), comprenant les étapes consistant à : 45
- fournir un élément inférieur (61a), un élément supérieur (61b) et une barre de rouleau (61r), 50
- fournir un élément d'extrémité inférieure (611a) et un élément d'extrémité supérieure (611b), supporter la barre de roulement (61r) sur l'élément inférieur (61a), 55
- raccorder de manière fixe l'élément d'extrémité inférieure (611a) à l'élément inférieur (61a),
- raccorder de manière pivotante l'élément d'extrémité inférieure (611a) à l'élément d'extrémité supérieure (611b), l'élément d'extrémité supérieure (611a) pouvant pivoter entre un état ouvert et un état fermé,
- raccorder de manière fixe, lorsque l'élément d'extrémité supérieure (611b) est dans l'état fermé, l'élément d'extrémité supérieure (611b) à l'élément supérieur (61b), et ainsi enfermer la barre de rouleau (61r) en raccordant l'élément supérieur (61b) à l'élément inférieur (61a), dans lequel un espace de barre (61p) est formé entre l'élément inférieur (61a) et l'élément supérieur (61b), de telle sorte que l'espace de barre (61p) loge, et limite un déplacement de, la barre de rouleau (61r).
- 15.** Procédé d'assemblage d'un boîtier supérieur (61) pour un agencement d'écran (50) selon la revendication 14, comprenant les étapes supplémentaires consistant à :
- fournir au moins une bobine d'enroulement (671),
- positionner la bobine d'enroulement dans un espace de bobine (71w) formé par l'élément d'extrémité inférieure (611a) et l'élément d'extrémité supérieure (611b), et
- raccorder l'au moins une bobine d'enroulement à une extrémité longitudinale de la barre de rouleau.

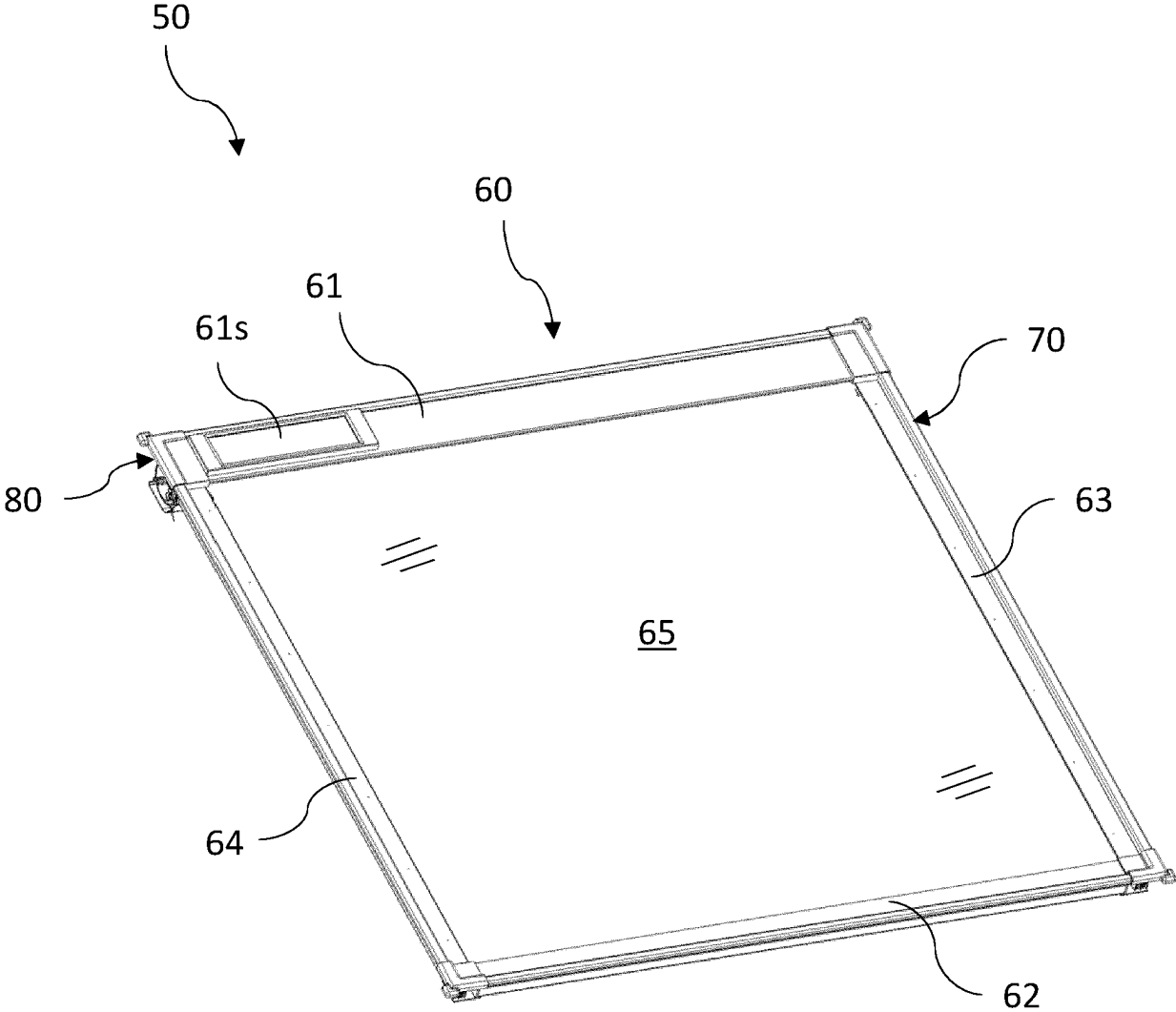

Fig. 1

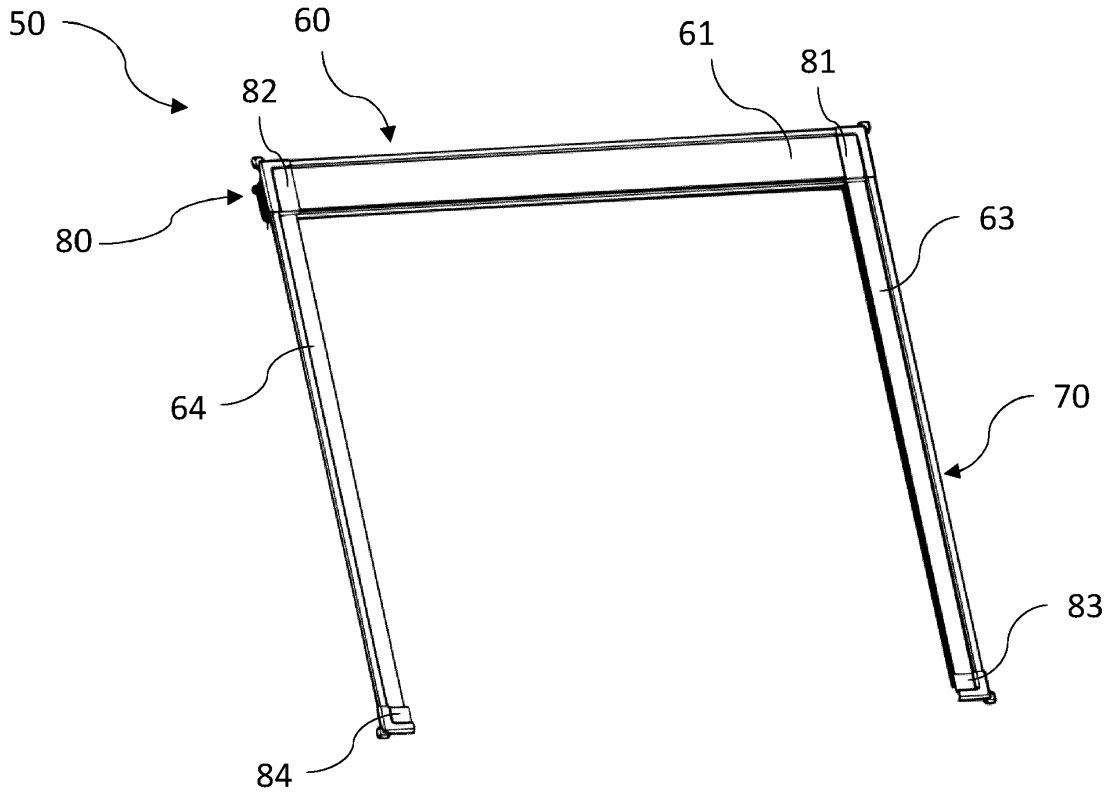

Fig. 2

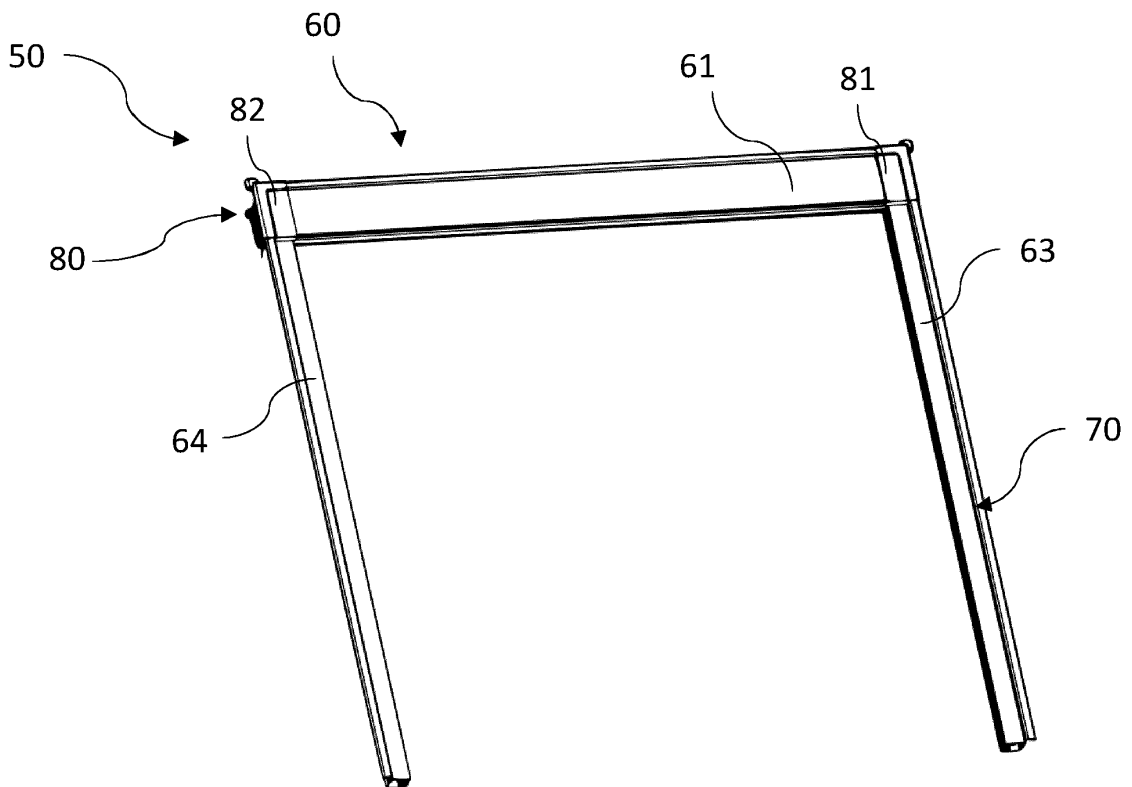

Fig. 3



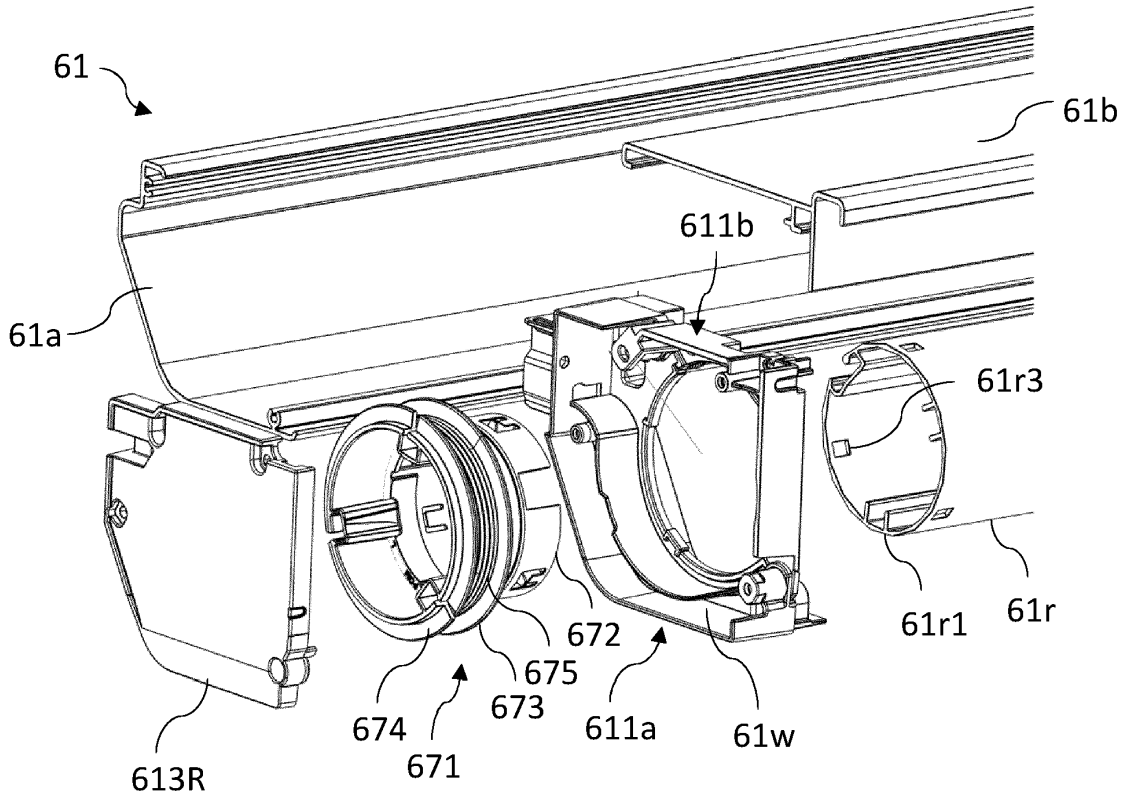

Fig. 5

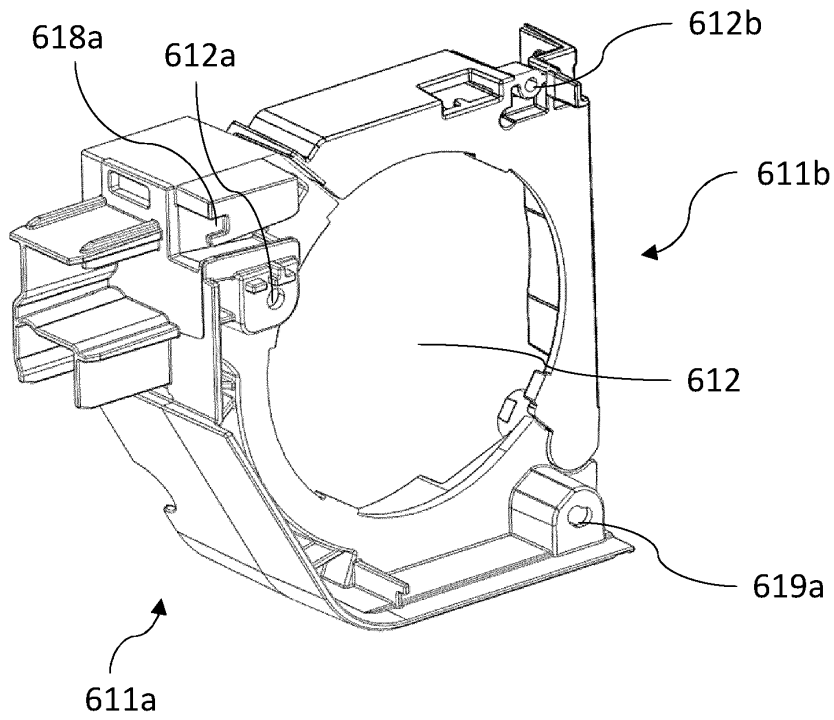

Fig. 6

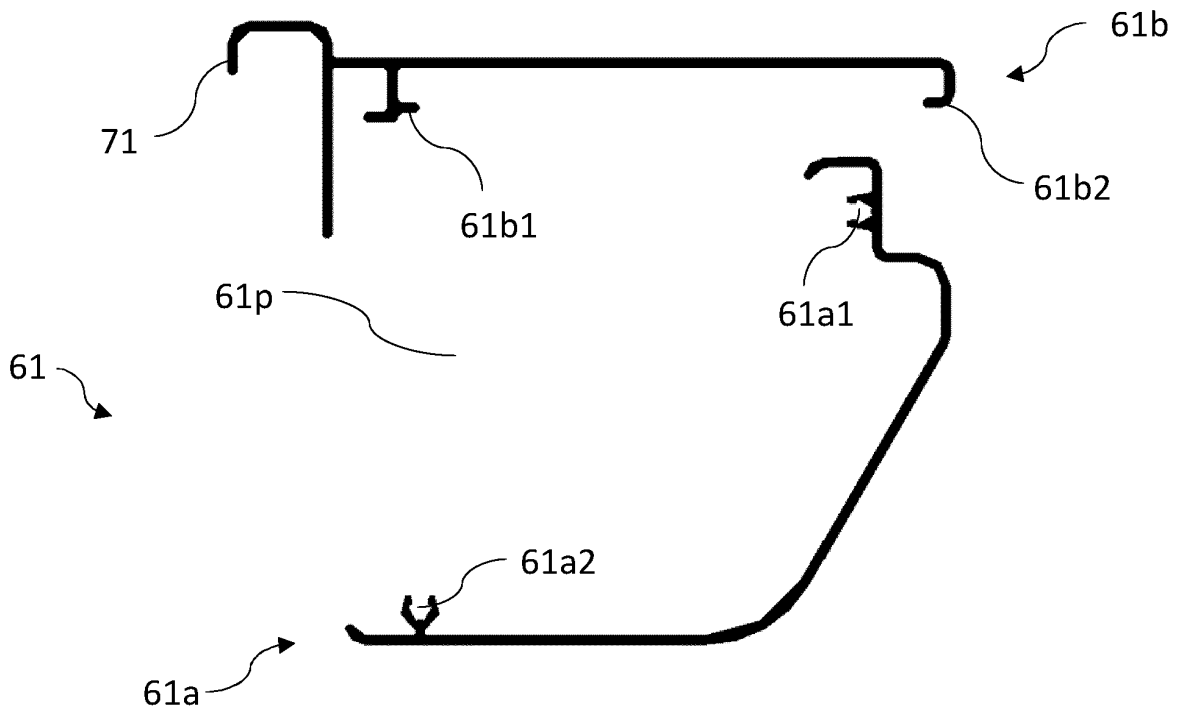

Fig. 7

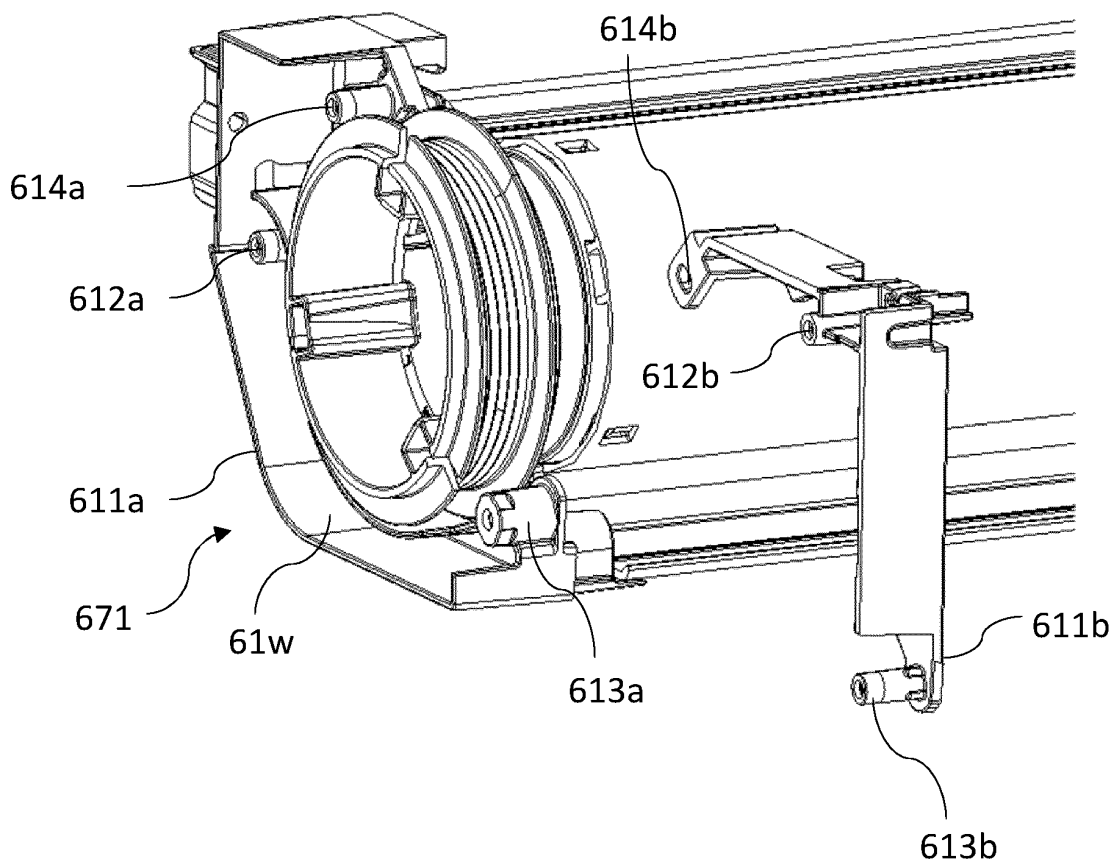

Fig. 8

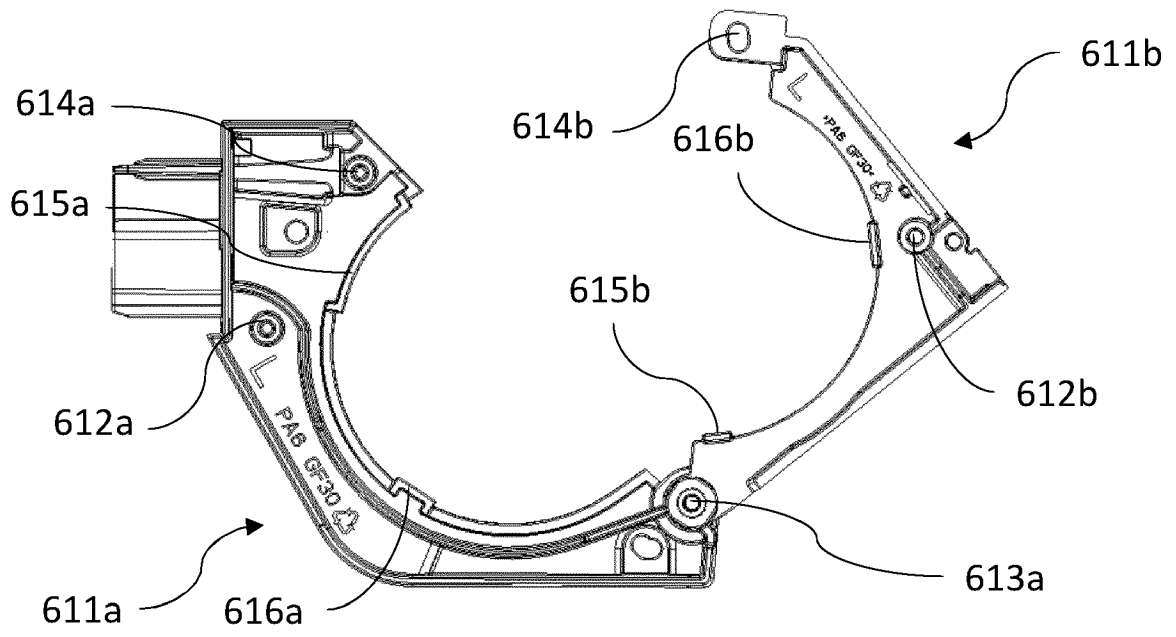

Fig. 9

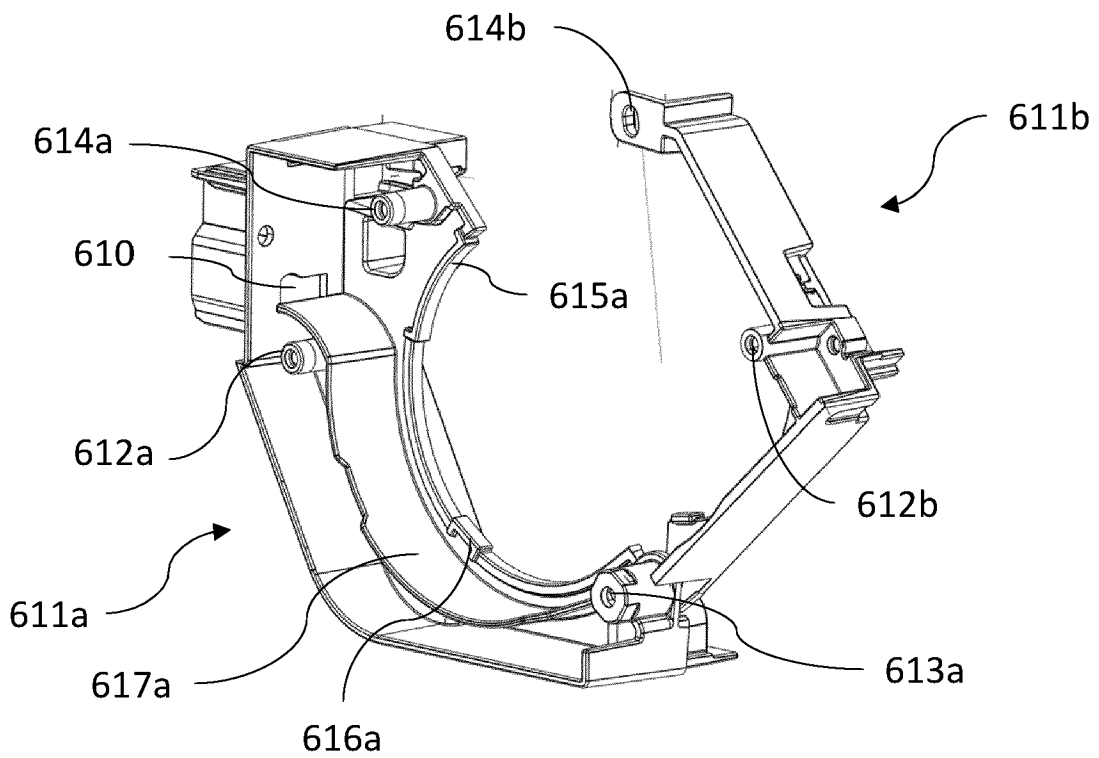

Fig. 10

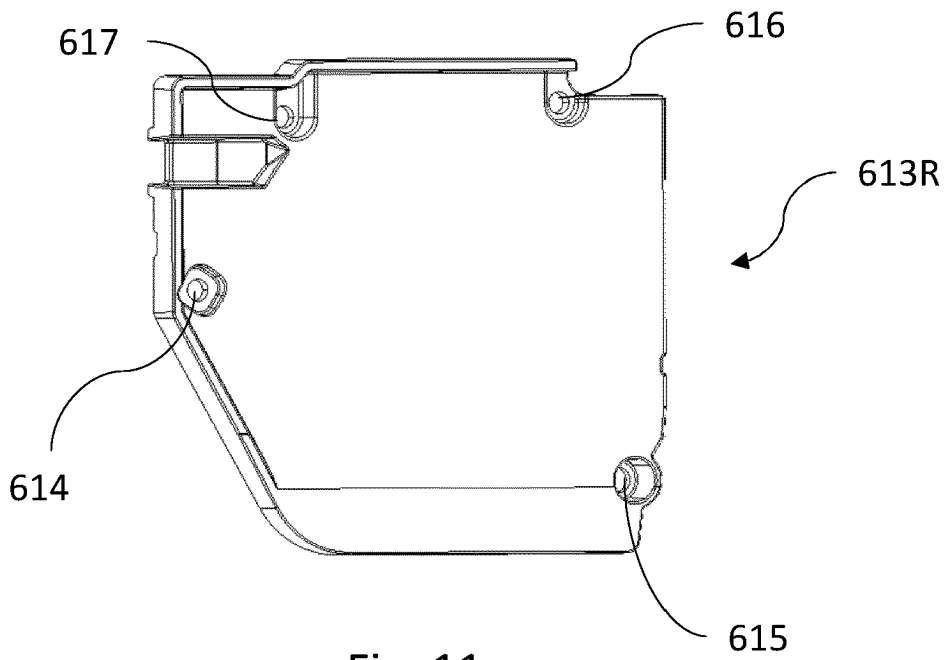

Fig. 11

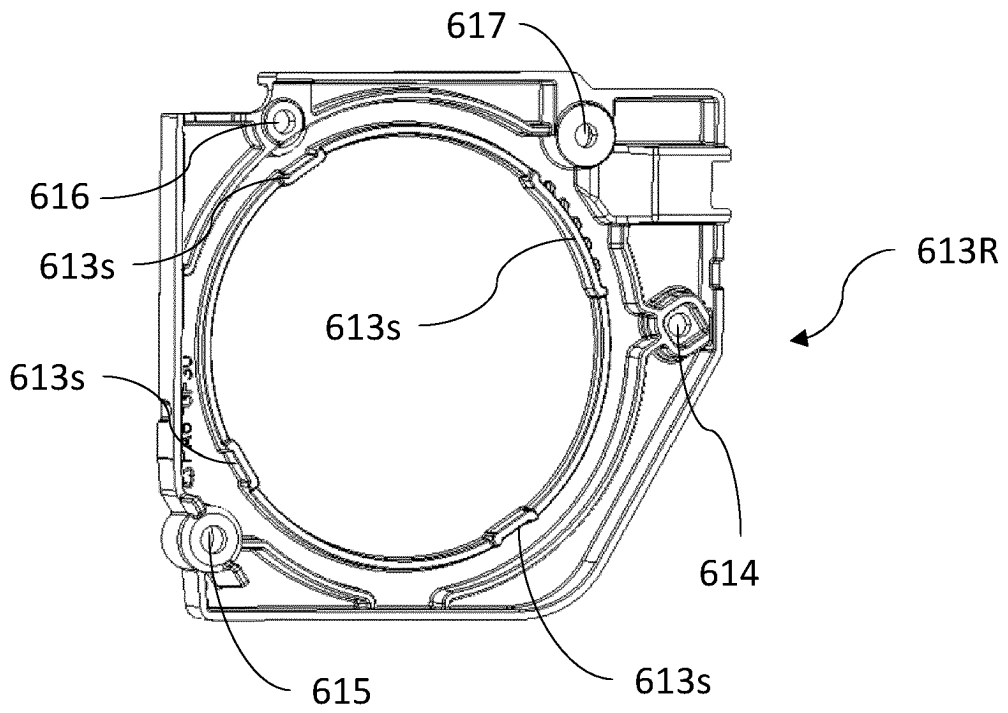

Fig. 12

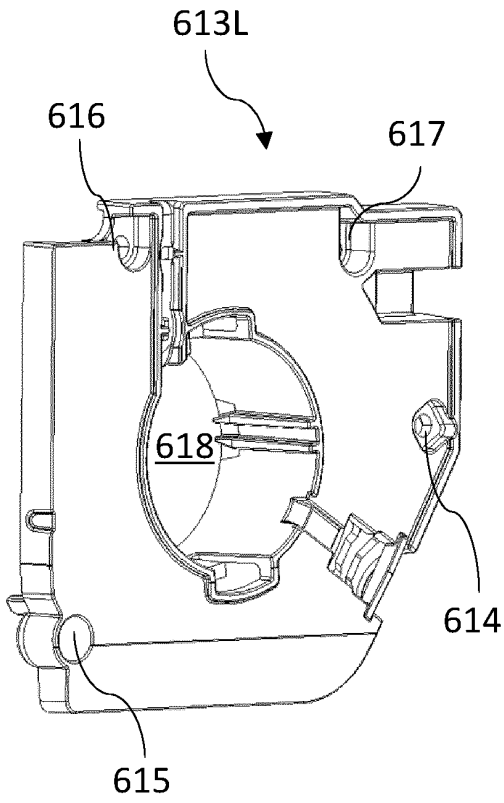

Fig. 13a

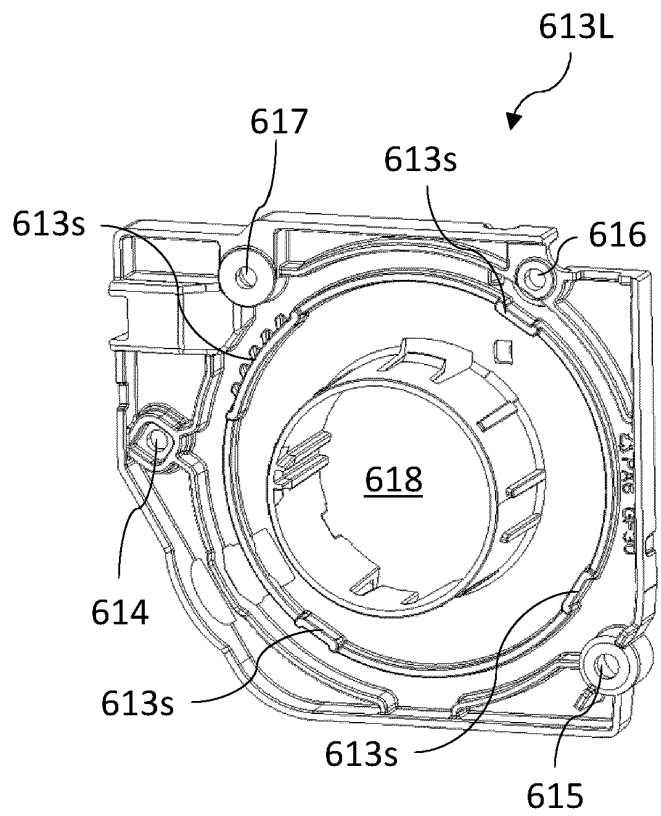

Fig. 13b

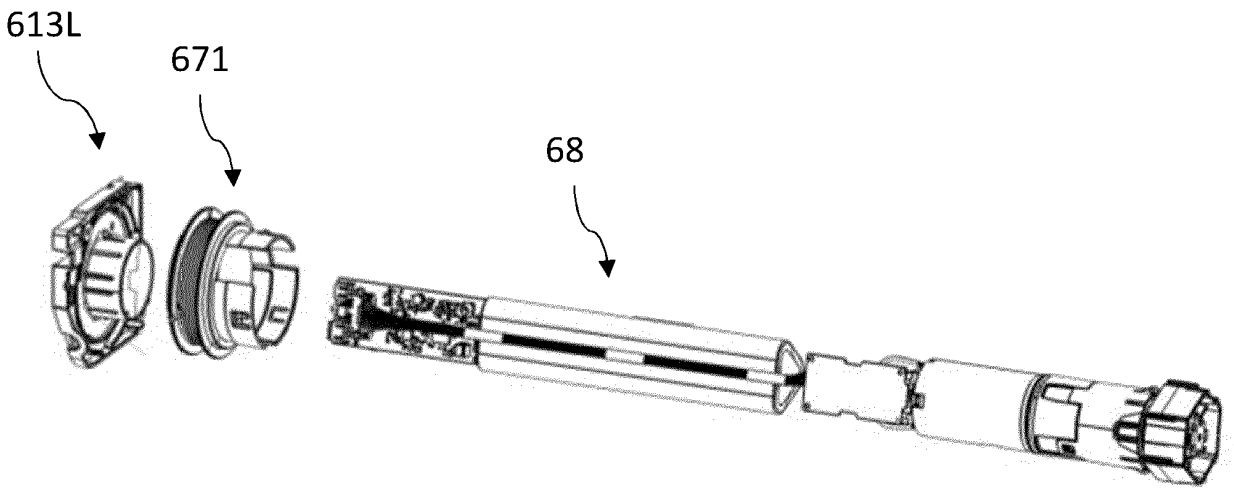

Fig. 14

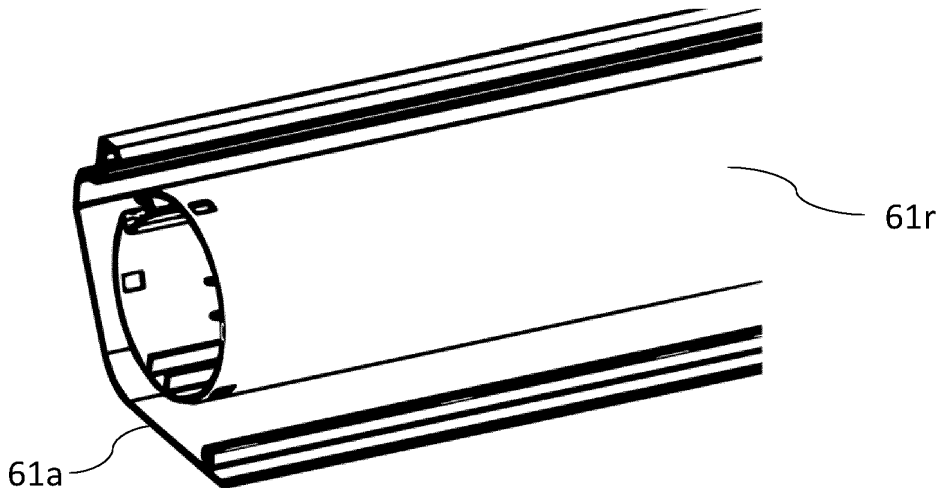

Fig. 15a

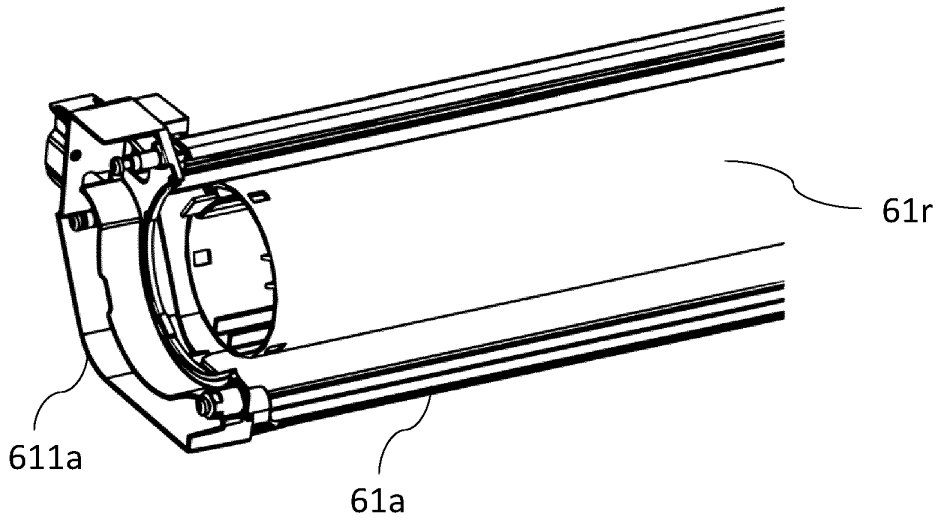

Fig. 15b

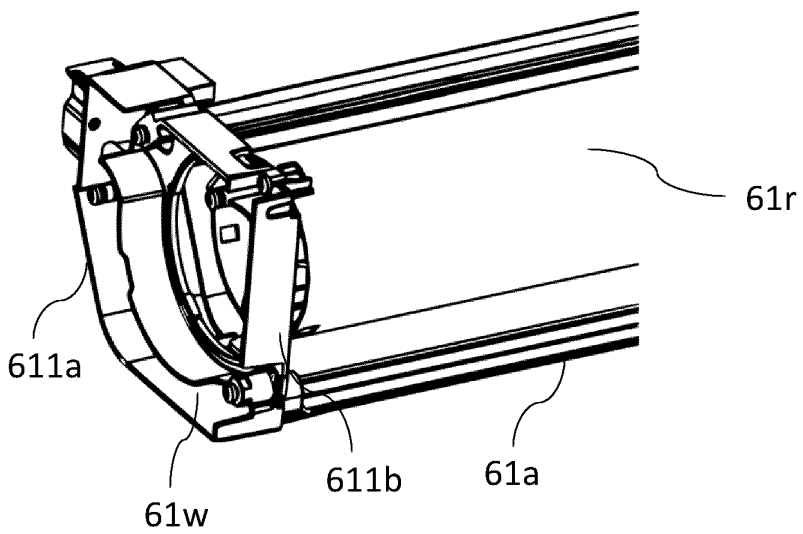
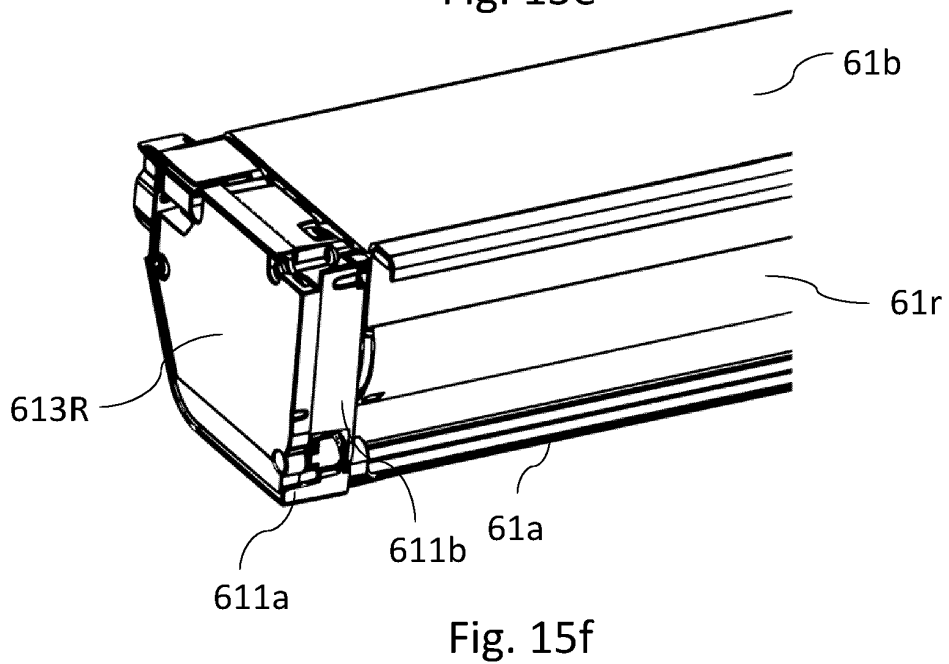
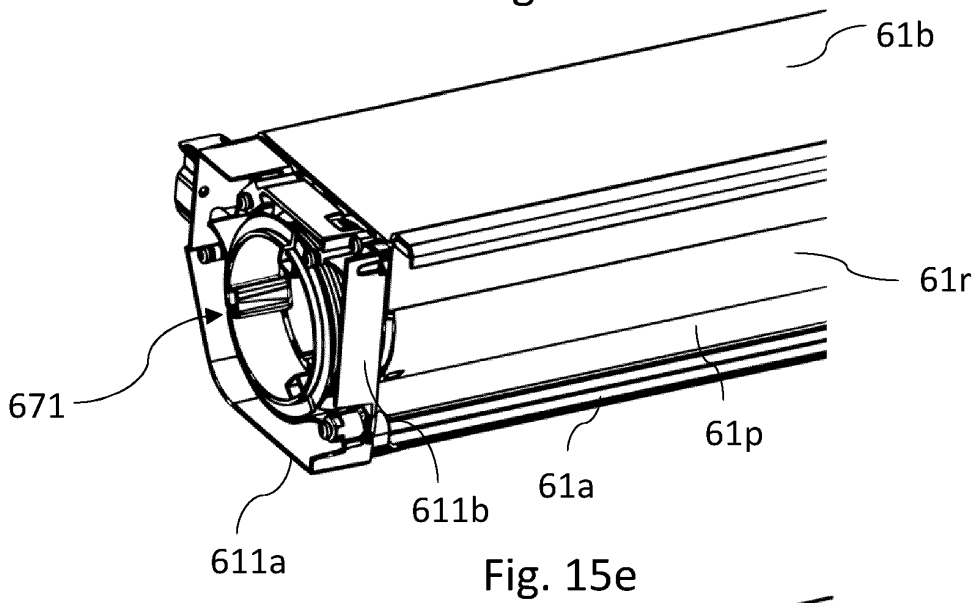
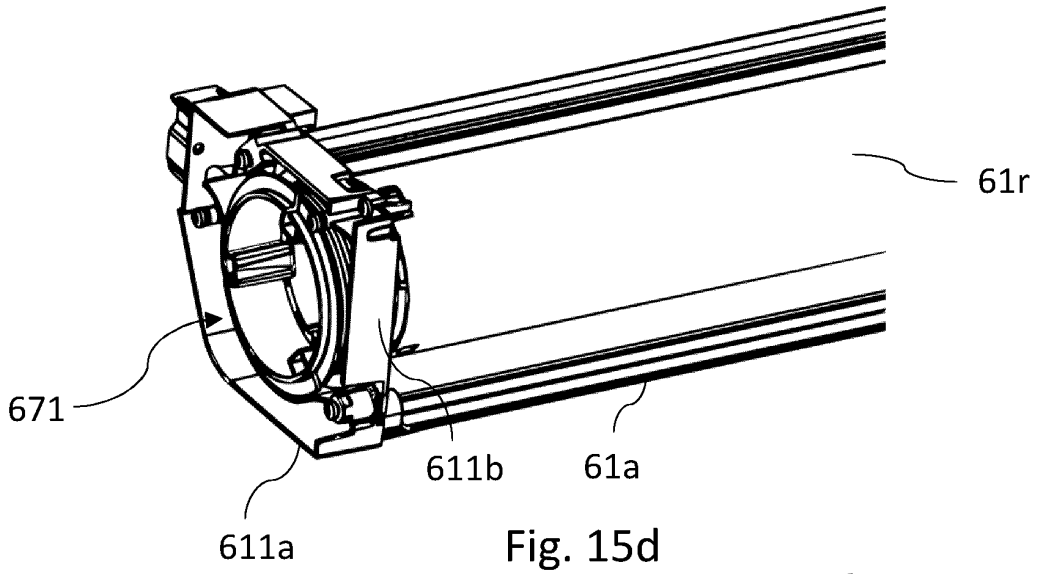

Fig. 15c



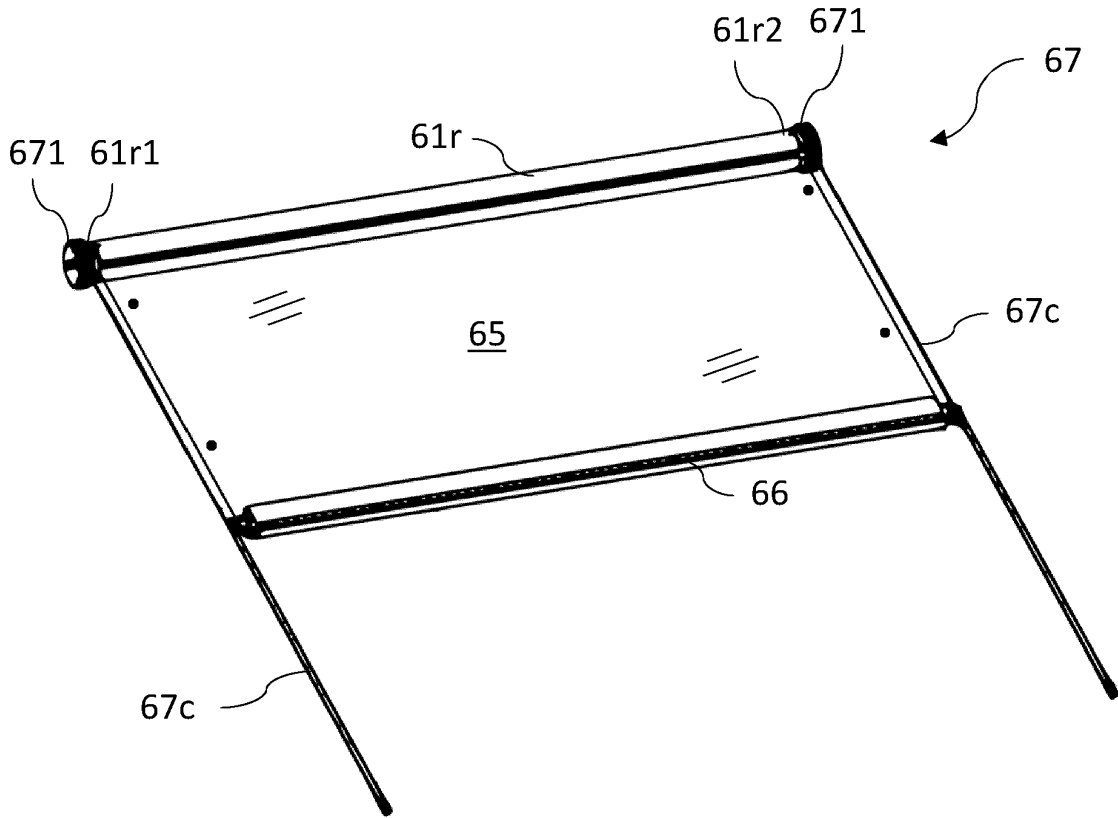

Fig. 16

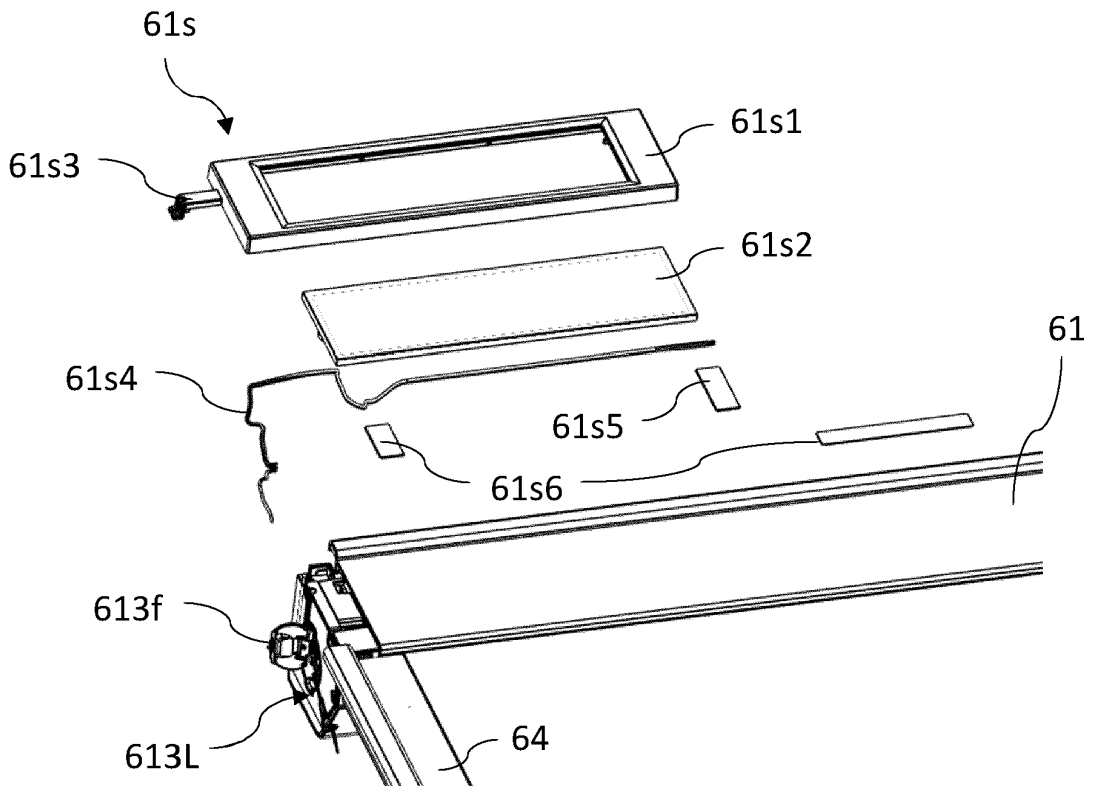

Fig. 17

**REFERENCES CITED IN THE DESCRIPTION**

*This list of references cited by the applicant is for the reader's convenience only. It does not form part of the European patent document. Even though great care has been taken in compiling the references, errors or omissions cannot be excluded and the EPO disclaims all liability in this regard.*

**Patent documents cited in the description**

- EP 2236731 A2 [0005]