

(No Model.)

J. W. HAYES.

METALLIC PACKING FOR STUFFING BOXES.

No. 387,591.

Patented Aug. 7, 1888.

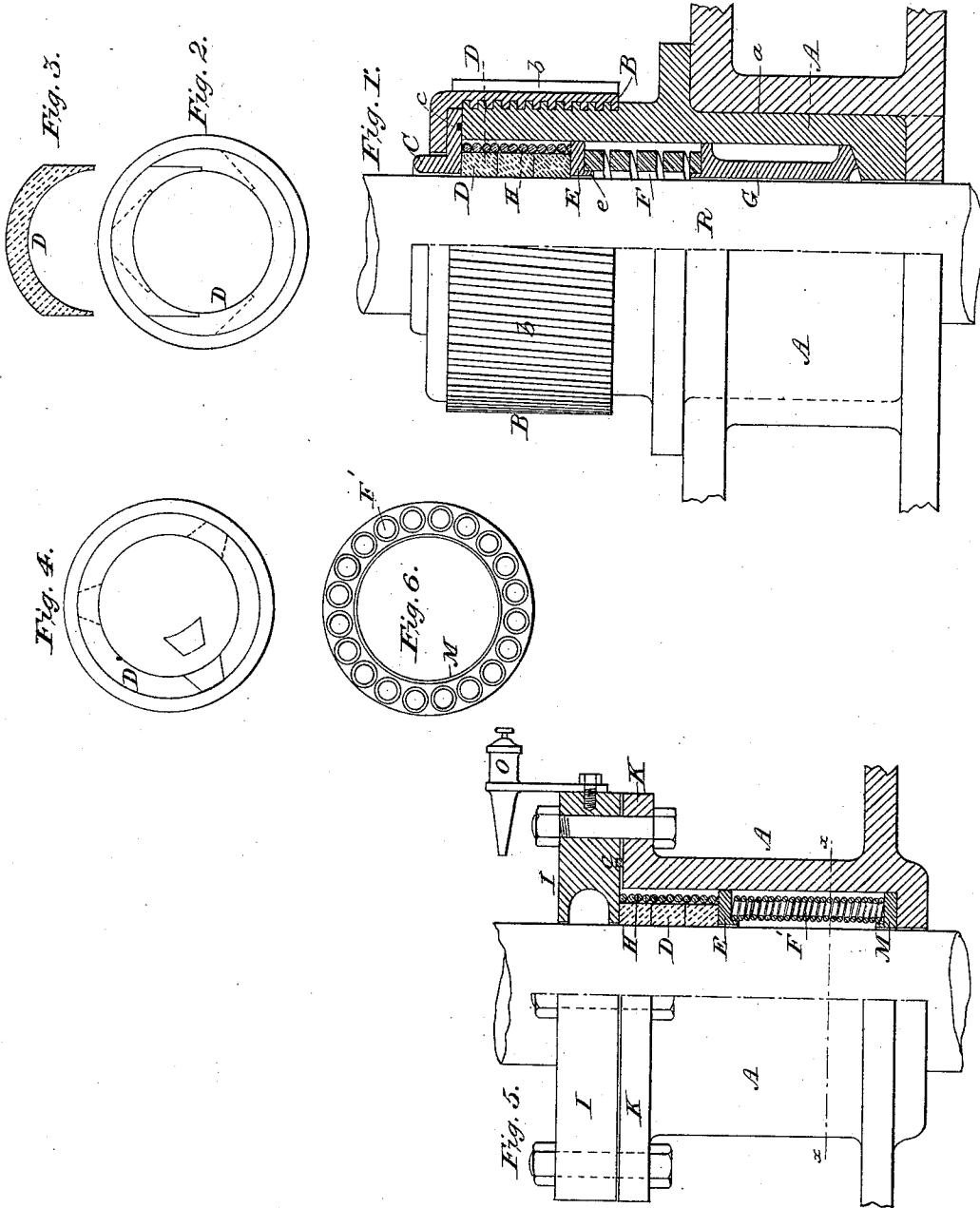

Witnesses:

Alfred M. Lang,  
Wallace S. Jackson.

Inventor:

John Wesley Hayes,

By J. C. Crockett

Attorney.

# UNITED STATES PATENT OFFICE.

JOHN WESLEY HAYES, OF PORTSMOUTH, NEW HAMPSHIRE, ASSIGNOR OF  
TWO-THIRDS TO WM. B. BROOKS, OF ERIE, PENNSYLVANIA.

## METALLIC PACKING FOR STUFFING-BOXES.

SPECIFICATION forming part of Letters Patent No. 387,591, dated August 7, 1888.

Application filed November 23, 1887. Serial No. 255,893. (No model.)

*To all whom it may concern:*

Be it known that I, JOHN WESLEY HAYES, a citizen of the United States, residing at Portsmouth, in the county of Rockingham and State of New Hampshire, have invented certain new and useful Improvements in Metallic Packing for Stuffing-Boxes; and I do hereby declare the following to be a full, clear, and exact description of the invention, such as will enable others skilled in the art to which it appertains to make and use the same.

My invention relates to improvements in metallic packing for stuffing-boxes for the rods of pistons, valve-stems, &c.; and the object is to produce a packing for a stuffing-box by which the rods of the pistons of engines, pumps, &c., as well as valve-stems, can be regularly and reliably packed to prevent leakage; also, to produce means by which the metallic packing-rings are automatically pressed against the piston-rod or its equivalent; furthermore, to produce face-plates at the opposite ends of the packing-rings with springs by which they are pressed together to prevent leakage laterally; also, to produce means by which the vibrations are overcome, or any irregularity in the movements of the rod can be accommodated; and, finally, to facilitate the manufacture of the metallic packing-rings.

With these objects in view my invention consists in constructing the packing-rings in sections, fitting into each other, and pressed together and against the rod by a spring encircling them, by which said packing-rings are regularly and evenly pressed against the rod with their entire interior diameter and prevent cutting or scoring of the rod, and supported between a face-plate and guide, being forced outward against the face-plate by a spring or a series of smaller springs placed around the rod. This spring or springs also serve to press the packing-rings together and prevent lateral leakage.

It also consists in the construction of a chuck and mold for manufacturing the packing-rings; and it finally consists in the construction of certain details and arrangement of parts, as will be more fully described hereinafter, and specifically pointed out in the claim, reference being had to the accompanying drawings and the letters of reference marked thereon.

Like letters indicate similar parts in the different figures of the drawings, in which—

Figure 1 represents a side elevation of my improved packing for a stuffing-box, partly in section. Fig. 2 is a plan view of the packing-rings, made in sections, one of which is shown in Fig. 3 detached. Fig. 4 is a similar view of a modification of the same. Fig. 5 is a similar view to Fig. 1 of a modified form of a stuffing-box with small springs for setting out the sectional rings. Fig. 6 is a horizontal section on line *xx* of Fig. 5.

In the drawings, A represents the outer shell or main body of the stuffing-box, made of any suitable size and material, and either separate or cast to the cylinder-head, a space, *a*, being formed around the rod R for the reception of the packing-rings and springs, &c. The gland B in Fig. 1 is of the kind screwed to the end of the body A by a worm-wheel meshing with the teeth *b*. A face-plate or guide-ring, C, is arranged between the end of the body A and the gland and is provided with a groove for the reception of a lead packing-ring, *c*, to prevent leakage. The packing-rings D are made in sections, as shown in Figs. 2, 3, and 4, and placed in the cavity *a*, and bear with their inner ends against the guide-ring E, having a small flange, *e*. A coiled spring, F, of slightly larger diameter than the rod, bears against the guide-ring, while its opposite or inner end bears against the end of the guide-ring G, made in this instance of elongated form, as seen in Fig. 1. The spring F may be made longer or shorter, as desired, or according to circumstances. A small space is left between the guide-ring and the rod for the passage of steam and to allow for vibrations of the rod. Another spring, H, is coiled around the packing-rings, by which they are pressed evenly and regularly with their entire inner diameter against the rod to prevent leakage, scoring longitudinally, and the packing-rings D are placed in the receptacle, so as to break joints, as indicated by the dotted lines. These packing-rings are preferably made of part tin and part antimony, although any other suitable material may be used.

In the modification shown in Fig. 5 the screw-gland is dispensed with and a flange, I, is bolted to the flange K of the body A. The

packing-rings D and spring H are similar to those shown in Fig. 1, and the lead packing-ring *c* is inserted in a groove in the flange I. Instead of the spring F, however, a series of small springs, F', are employed in this case and are placed between the guide-rings E and M. If desired, an oil-cup, O, may be secured to the flange K for lubricating the rod.

The packing-rings are preferably made by a mold, as shown in Figs. 7 to 11, and finished and faced, as desired, to fit the rod.

The operation is as follows: The guide-rings E, G, or M, with spring F or springs F', are first inserted into the cavity *a*, the packing-rings D and spring H next, and the guide-ring C or the flange I, with lead ring *c*, are then placed in position and the gland B or the flange I secured either by screwing it home by the worm, as in Fig. 1, or by the bolts and nuts, as in Fig. 5. If the engine is started, the steam, which is freely admitted from the cylinder, will press the packing-rings, assisted by the springs and face-plates, against the rod, causing the packing to hug the rod automatically and prevent any leakage past the joints of the packing-rings or the rods and packing.

I am aware that, broadly, none of the elements claimed in this invention are new in

themselves and only in combination, arranged as shown, form a new and improved stuffing-box; and I do not, broadly, therefore claim the sectional packing, the springs, the guide-rings, or the receptacle.

I am aware of the stuffing-box patented to McPherson & Thayer, No. 100,213, and disclaim the construction therein shown; but,

Having thus described my invention, what I claim, and desire to secure by Letters Patent, is—

The stuffing-box herein described, consisting of the detachable receptacle A, containing the sectional packing-rings D, the spiral encircling spring H, pressing said rings evenly against the rod on its perimeter, and the flanged guide-rings, in combination with the tension-springs, one or more, exerting a longitudinal pressure against said rings D, and the follower C, provided with the lead packing-ring *c*, all constructed and arranged as herein shown, and for the purpose set forth.

In testimony whereof I hereby affix my signature in presence of two witnesses.

JOHN WESLEY HAYES.

Witnesses:

CALVIN PAGE,  
WALLACE S. JACKSON.